

FAST COOLING TIME MEASUREMENTS IN CELSIUS USING A THIRD GENERATION MOBILE PHONE SIGNAL PROCESSING DEVICE

T. Lofnes, V. Ziemann, The Svedberg Laboratory, 75121 Uppsala, Sweden

Abstract

We present hardware to measure longitudinal cooling times of electron cooled ion beams in CELSIUS. The measurements are performed by an a fast ADC and a AD6620 receiver signal processor evaluation board that we interfaced to a Linux PC. The specialized signal processors are developed for third generation mobile phone systems and consist of several digital mixing, filtering, and down-sampling stages. We describe the measurements and the hardware that allows us to record and analyze high resolution spectra at very high update rates.

1 INTRODUCTION

In order to generate high resolution spectra of a signal sampled with a high frequency, time-consuming down-conversion techniques has to be used in the subsequent software. This leads to a time delay, that limits the update rate of the spectra. In a specialized Digital Signal Processor developed for 3rd generation mobile telephony, these algorithms, normally used in software for down-converting high frequency signals, are coded in hardware, and consequently are very fast. Inspired by the possibilities of this DSP, we decided to use it for frequency measurements. In the following sections we discuss the hardware, the software, and some applications.

2 HARDWARE

The analog input signal, to be analyzed, is digitized by an Analog Devices AD-6644, a 14 bit ADC, running at 66 Mhz. The ADC is mounted on an Analog Devices evaluation board. The digitized signal is sent to a Receiver Signal Processor, a DSP specialized for a small number of tasks, which then in turn can be handled much more efficiently. This RSP is an Analog Devices AD6620 [1], also running at 66 Mhz. The RSP performs mainly three tasks. First the frequency range of interest is downconverted to baseband by multiplying (mixing) the input signal with a complex IF signal. Out of band signals are then removed in a low pass filter. The resulting signal occupies less bandwidth than the input signal. This means, according to Nyquist, that the sample rate can be decimated. Decimation is made by simply discarding samples which are redundant. The filtering and decimation are made in three stages on the RSP. The first stage decimates with a factor of 1 to 16, the following two with a factor of 1 to 32. This way the original data rate of 66 Msamples per second can be reduced by a factor of up to 16384, resulting in a data

stream as low as 4 k samples per second. This is done in a pipelined process that no information, within the band of interest, is lost. After decimation the complex signal is stored in a 32 k word FIFO buffer memory. A second mode allows the data from the ADC to be stored directly in the FIFO. From the FIFO the data is sent to a Linux host PC over the parallel port. The RSP and the FIFO memory are mounted on an Analog Devices evaluation board. Using evaluation boards has the advantage, that the printed circuit board layout is already done expertly, which reduces the cost and development time. Moreover the ADC has an analog input bandwidth of 250 MHz, which makes it suitable for undersampling applications. In this case analog bandpass filters has to be used before digitizing the signal in the ADC.

As a result of the decimation a large amount of the quantization noise has been removed from the signal. This improvement of the signal to noise ratio, referred to as the processing gain, can with a high decimation rate be as high as 42 dB.

3 SOFTWARE

The software supplied with the RSP is neither fast nor flexible enough. So we have developed our own code on a Linux PC using the standard gnu-C compiler and the libsx library [2] as an X-windows toolkit. The host runs an X-windows application, which has a graphical user interface

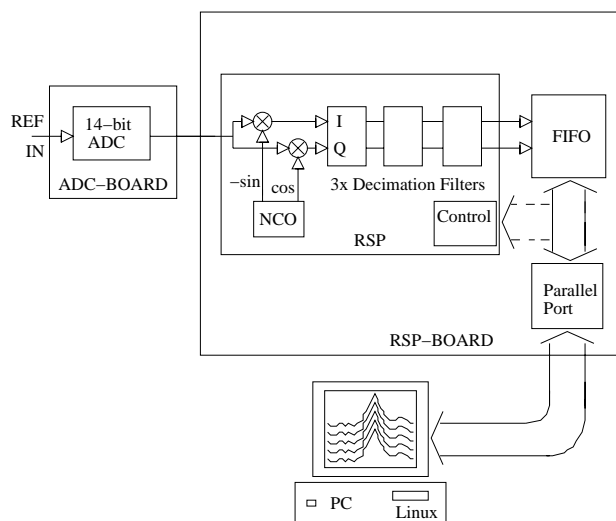

Figure 1: The block diagram of the Hardware. The NCO unit is a numerically controlled oscillator

[GUI] that can be seen in Fig. 2. In the lower half of the window one single spectrum is shown in a scope like mode displaying amplitude versus frequency. In the upper half the 256 most recent spectra are visible. Here the amplitude is coded in color or grayscale, whereas the vertical axis is showing time. All the different settings are made in the GUI. For instance the frequency band of interest can be set, by choosing center frequency and frequency-range. From these settings the appropriate values of NCO frequency, decimation factors and filter constants are calculated and sent to the RSP control registers, over the parallel port. Once the samples are downloaded from the FIFO, the program calculates the frequency spectra with an complex FFT. With a reasonable fast PC, 400 MHz or more, 32 frequency spectra will be displayed per second. This means that measurements with a frequency resolution of, from 32 Hz down to 2 Hz, can be displayed with maximum theoretical speed. If higher speed is wanted, with broader frequency band, there is an option to postpone the FFT calculation, and store the samples directly on the harddrive. Of course this means that the spectra can only be seen afterwards. This way more than 100 spectra per second can be achieved. This has not been implemented yet.

4 MEASUREMENTS

We have used the RSP based data acquisition system to analyze various beams in CELSIUS.

In undersampling applications a network or spectrum an-

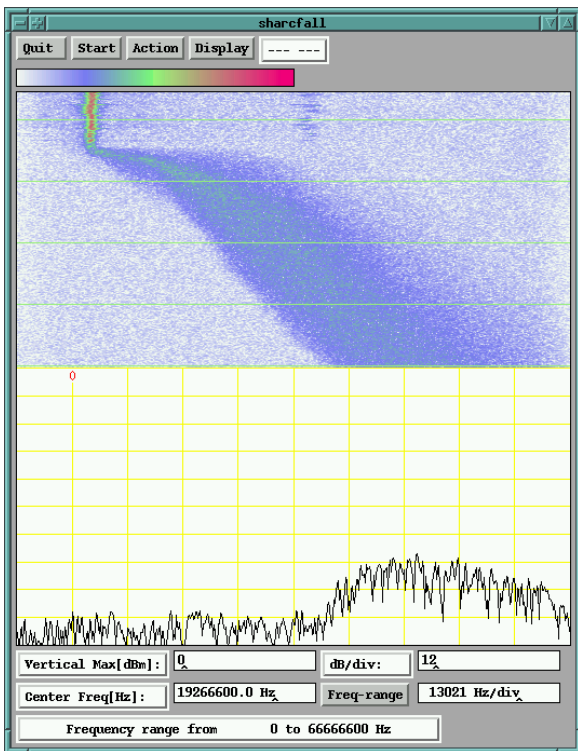
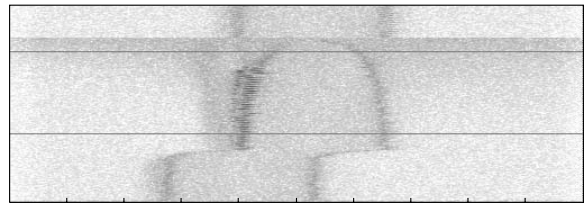

Figure 2: The graphical user interface of the RSP based spectrum analyzer.



6500 Hz/div, center=116.4175 MHz

Figure 3: Spectra of 0.7 mA electron-cooled protons at 48 MeV, observed at the 103rd harmonic. 65 kHz full span.

alyzer can be used as a bandpass filter and amplifier, if running in zero span mode. In this case the 2nd IF output of the analyzer is used as an input to the ADC. When using our Marconi spectrum analyzer the IF signal is located at 47.4 MHz. This frequency is mirrored to 19.26 MHz by the Nyquist frequency of the ADC. This explains why the frequency scale in Fig 2-5 is inverted, ie from right to left.

In Fig. 3 we show the Schottky spectra of 0.7 mA electron-cooled protons with a kinetic energy of 48 MeV, observed at the 103rd harmonic at 116.4 MHz. The electron current is 110 mA in this situation. Time flows from top to bottom. Near the top the previous fill is visible and then, immediately after injection the spectrum is very wide, as shown by the dark band but immediately afterwards the cooling force causes the characteristic double peaks to develop. Near the bottom of Fig. 3 the speed of the cooling electrons was changed by 4 V which causes the speed of the protons to jump.

In Fig. 4 we show the Schottky spectra of 100 MeV/u electron-cooled nitrogen ions in the presence of a gas jet

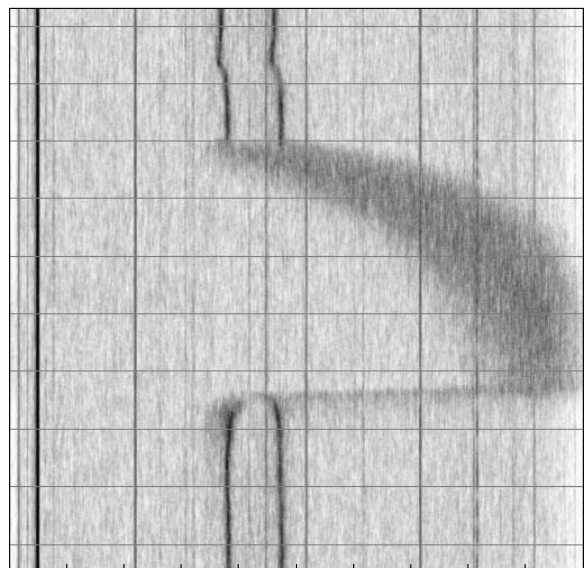

6500 Hz/div, center=116.4171 MHz, 2 s/tick

Figure 4: Spectra of 1.5 mA electron-cooled nitrogen ions at 100 MeV/u, observed at the 60th harmonic. 65 kHz full span.

target. Near the top the double-peak structure is clearly visible and after the second vertical tick mark the electron cooler is turned off and the Schottky spectra blow up and move towards the right due to the fact that the beam loses energy by the target interaction and also blows up, because the cooling force is missing. After about 11 s the cooler is turned on and, after an initial collection phase, the double peaks reappear.

In Fig. 5 we show the Schottky spectra of electron-cooled nitrogen ions, observed at the 145th harmonic at 117.852 MHz. We repeated the same exercise as before albeit at much lower current of $20 \mu\text{A}$ and much at injection energy without target. Due to the small current the beam does not exhibit double peaks and due to the absence of a target the energy loss due to rest gas is much smaller than before. Near the bottom of Fig. 5, when the cooler is turned on again the beam actually overshoots. We do not

yet know whether that is due to the beam's physics or the power supply.

5 CONCLUSIONS

We describe an inexpensive, fast, and high resolution spectrum analyzer based on a receiver signal processor evaluation board from Analog Devices supplemented by some driver software and a GUI interface that we use to analyze beams in CELSIUS.

6 REFERENCES

- [1] <http://products.analog.com/products/info.asp?product=AD6620>
- [2] <http://metalab.unc.edu/pub/Linux/X11/libs/clients/libsx.tar.gz>

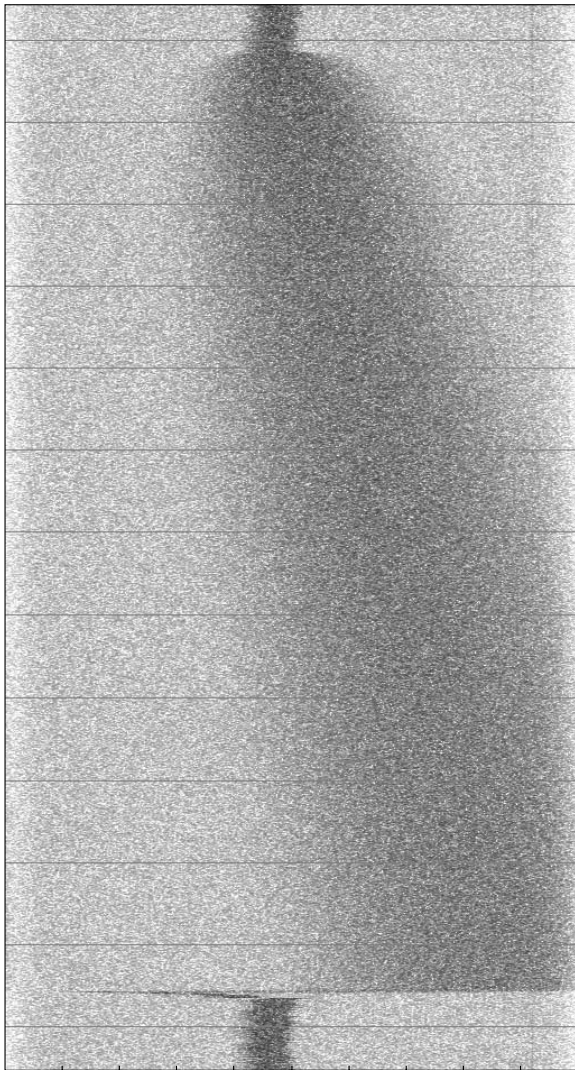

6500 Hz/div, center = 117.852 MHz, 2 s/tick

Figure 5: Spectra of $20 \mu\text{A}$ electron-cooled nitrogen ions, observed at the 145th harmonic. 132 kHz full span.