



ISSN (Print) : 2320 – 3765
ISSN (Online): 2278 – 8875

International Journal of Advanced Research in Electrical, Electronics and Instrumentation Engineering

(An ISO 3297: 2007 Certified Organization)

Vol. 4, Issue 1, January 2015

Wind Energy Conversion System Connected With Grid Using Permanent Magnet Synchronous Generator (PMSG)

Sourav Ghosh¹, Prof. Pradip Kumar Saha², Prof. Gautam Kumar Panda³

PG scholar, Department of Electrical Engineering, Jalpaiguri Government Engineering College, Jalpaiguri, West Bengal, India¹

Professor, Department of Electrical Engineering, Jalpaiguri Government Engineering College, Jalpaiguri, West Bengal, India²

HOD and Professor, Department of Electrical Engineering, Jalpaiguri Government Engineering College, Jalpaiguri, West Bengal, India³

ABSTRACT- This paper deals with permanent magnet synchronous generator (PMSG) based wind energy conversion system (WECS) integrated with grid with two back to back connected converters with a common DC link. The aim of this research is to model control of direct driven 1.5 MW wind turbine permanent magnetic synchronous generator (PMSG) which feeds alternating current (AC) power to the utility grid. The machine side converter is used to extract maximum power from the wind. In this paper a study of WECS is done by using a constant speed direct-driven wind turbine in Matlab. Moreover, by maintaining the dc link voltage at its reference value, the output ac voltage of the inverter can be kept constant irrespective of variations in the wind speed and load. An effective control techniques to extract maximum power from wind turbine is maximum power point tracking controller (MPPT), grid side controller also called voltage controller, pitch controller, phase lock loop controller (PLL) also used in this project, transformer used for isolation purpose, crow bar circuit used for protection the whole system.

KEYWORDS-Permanent magnet synchronous generator(PMSG), wind energy conversion system(WECS), back to back PWM converter IGBT based, DC link capacitor, Direct-Driven, MPPT controller, PLL loop, generator side converter control, grid side converter control, pitch controller, crow bar protection and transformer.

I. INTRODUCTION

In recent years, the electrical power generation from renewable energy sources, such as wind, is increasingly attraction interest because of environmental problem and shortage of traditional energy source in the near future. Nowadays, the extraction of power from the wind on a large scale became a recognized industry. It holds great potential showing that in the future will become the undisputed number one choice form of renewable source of energy. The force that pushes this technology is the simple economics and clean energy. As a consequence of rising fossil fuel price and advanced technology, more and more homes and businesses have been installing small wind turbines for the purposes of cutting energy bills and carbon dioxide emissions, and are even selling extra electricity back to the national grid.

The kinetic energy in the wind is converted into mechanical energy by the turbine by way of shaft and gearbox arrangement because of the different operating speed ranges of the wind turbine rotor and generator. The generator converts this mechanical energy into electrical energy. Then generator side PWM converter convert this AC power into DC power, grid side converter convert this DC power into AC power and send to grid. However, as wind is an intermittent renewable source, the wind source extracted by a wind turbine is therefore not constant. For this reason, the fluctuation of wind power results in fluctuated power output from wind turbine generator. From the point of view of utilities, due to the fluctuation of generator output, it's not appropriate for the generator to be

International Journal of Advanced Research in Electrical, Electronics and Instrumentation Engineering

(An ISO 3297: 2007 Certified Organization)

Vol. 4, Issue 1, January 2015

directly connected to the power grid. In order to achieve the condition that the generator output power is suitable for grid-connection, it is necessary to use a controller to manage the output produced by the wind turbine generator.

Permanent magnet machines are characterized as having large air gaps, which reduce flux linkage even in machines with multi-magnetic poles. As a result, low-rotational-speed generators can be manufactured with relatively small sizes with respect to its power rating. Moreover, the gearbox can be omitted due to low rotational speed in the PMSG wind generation system, thus resulting in low cost. To increase the efficiency, to reduce the weight of the active parts, and to keep the end winding losses small, direct-drive generators are usually designed with a large diameter and small pole pitch. Compared with the traditional electrically excited synchronous generator, the requirement of a larger pole number can be met with permanent magnets which allow small pole pitch. In addition, permanent magnet synchronous generators (PMSGs) have the high torque density and the absence of excitation losses. Furthermore, the performance of PM's is improving and the cost of PM is decreasing in recent years, the direct-drive permanent magnet wind generators have recently received increasing attention, especially for offshore wind energy. Thanks to the application of high energy PM materials such as neodymium-iron-boron, the volume and cost of this type of machine can be dramatically reduced. The distinct advantages offered by PMSGs are simple rotor design without field winding. The absence of field windings also results in higher efficiency since heat dissipation is avoided. PMSG is gaining a lot of attention for WECS due to compact size, high reliability higher power to weight ratio, reduced losses and robustness.

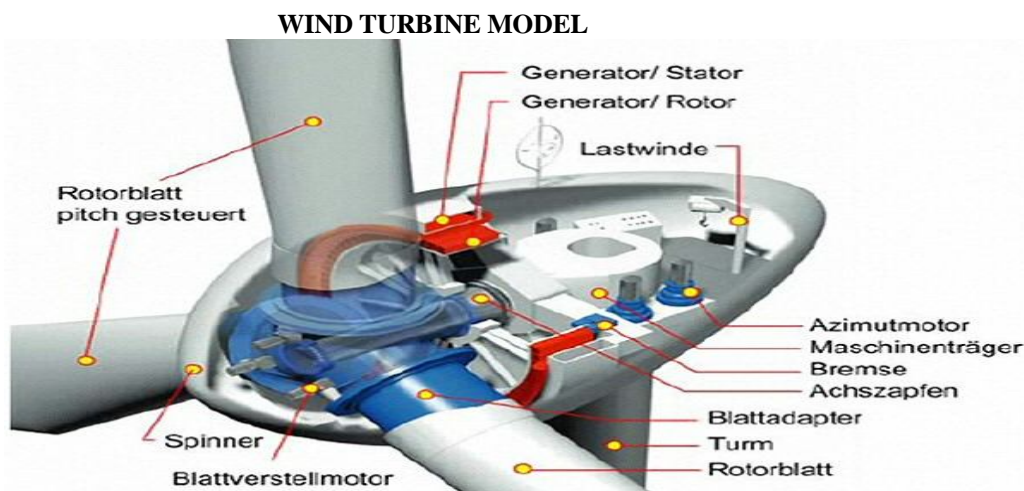

II. MODEL OF PMSG WIND TURBINE

(A) Structure of PMSG Wind Turbine: The basic of PMSG wind turbine structure shown on Figure 2. The wind turbine generates torque from wind power. The torque is transferred through the generator shaft to the rotor of the generator. The generator produces an electrical torque, and the difference between the mechanical torque from the wind turbine and the electrical torque from the generator determines whether the mechanical system accelerates, decelerates, or remains at constant speed.

The generator is connected to a three-phase inverter which rectifies the current from the generator to charge a DC-link capacitor, The DC-link feeds a second three-phase inverter which is connected to the grid through a transformer. Through the control system, the information of wind speed, pitch angle, rotor RPM, and inverter output is accepted to compare with the grid-side data. Therefore, this information is solved by using a digital signal processing system to produce the correct signal to control these components. The main goal is to synchronize with utility grid and to export power to it.

International Journal of Advanced Research in Electrical, Electronics and Instrumentation Engineering

(An ISO 3297: 2007 Certified Organization)

Vol. 4, Issue 1, January 2015

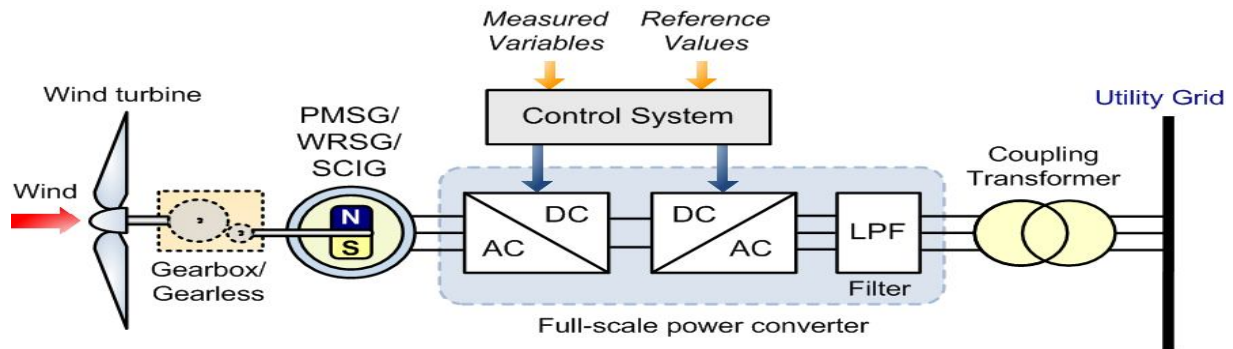

Fig-2.General wind turbine PMSG system with control schemes

(B).Model of Wind Turbine: The wind turbine analyzed is a classic three-bladed horizontal-axis (main shaft) wind turbine design with the corresponding pitch controller. The output mechanical power available from a wind turbine can be expressed through the following algebraic relation

$$P_m = C_p(\lambda, \beta) \frac{\rho A V^3}{2}$$

Where, ρ - air density

V – Wind Speed

C_p - Coefficient of Performance (or Power Coefficient) of the wind turbine

A – Area swept by the rotor blades of the wind Turbine

The power coefficient C_p is a nonlinear function of the blade pitch angle β and the tip-speed ratio by λ as given by,

$$\lambda = \left(\frac{R \omega_m}{V} \right)$$

Where, ω_m - Angular speed of the turbine rotor, R-Radius of the turbine Blades

The power coefficient C_p can be expressed as,

$$C_p(\lambda, \beta) = C_1 \left(\frac{C_2}{\lambda_i} - C_3 \beta - C_4 \right) \exp \left(\frac{-C_5}{\lambda_i} \right) + C_6 \lambda$$

$$\frac{1}{\lambda_i} = \frac{1}{\lambda + 0.08 \beta} - \frac{0.035}{\beta^3 + 1}$$

The torque of the wind turbine can be expressed as

$$T = \frac{1}{2} C_t(\lambda, \beta) \rho A V^3$$

$$C_t(\lambda, \beta) = C_p(\lambda, \beta) / \lambda$$

The given figure shows that the various power curve of wind turbine with various speed Fig.3. The curve of power wind turbine coefficient.

International Journal of Advanced Research in Electrical, Electronics and Instrumentation Engineering

(An ISO 3297: 2007 Certified Organization)

Vol. 4, Issue 1, January 2015

axis moderate to control active and reactive power. The inner current loop is controlled by PI controller similar to generator-side inverter. The out-put voltage loop produced PI controller for calculating the error between U_{dc} and $U_{dc(ref)}$ produced $i_d(ref)$. Therefore q-axis current is set to zero to decoupling control of the active power P and reactive power Q by mode rating the d-axis current i_d and q-axis current i_q .

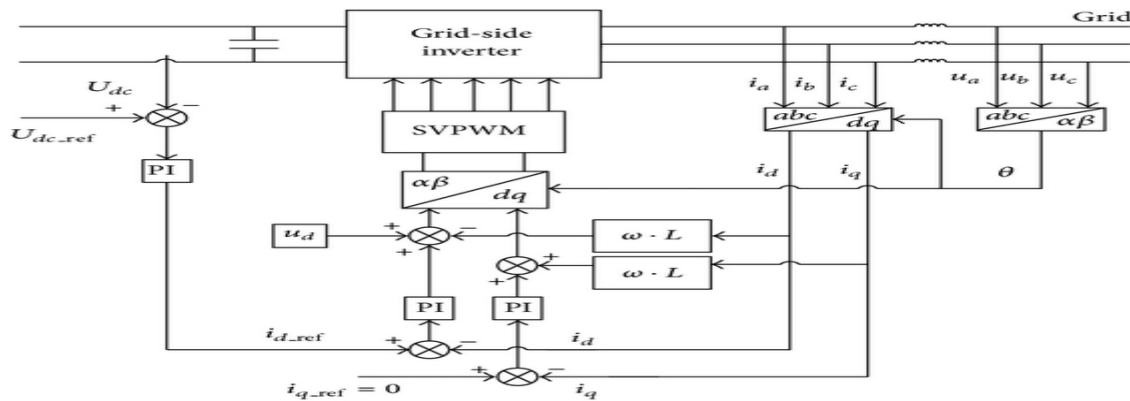

Fig.6. Grid –side inverter control

(C) Pitch angle control:- The system of aerodynamic control plays an important role in regulating the mechanical power. Pitch angle controller is based on the principle which is changing the blades angle at the revolutions over the maximal generator speed as well as protecting the generator before overloading at high wind speeds. The optimal angle for the wind speed below the nominal value is approximately zero and then it increases with the wind speed growing. It has considerable impact on the performance coefficient and on the value of the turbine torque in

(D) MPPT control:- The MPPT is a control method which control the wind turbine rotor speed by controlling torque of the generator. The blade pitching drive is a mechanical equipment which has a delay in response time in rapidly changing wind condition. However in, order to maximize the power production the rotor speed of the generator can be controlled electrically. This is usually done by adopting the rotor speed to the optimum tip speed ratio.

(E) PLL Control:- It is a control system that generates an output signal whose phase is related to the phase of an input signal. It is easy to initially visualize as an electronic circuit consisting of variable frequency oscillator and a phase detector. The oscillator generates a periodic signal. The phase detector compares the phase of the signal with the phase of the input periodic signal and adjust the oscillator to keep the phase matched.

IV. BACK TO BACK PWM INVERTER

WECS consist of a PMSG connected to a AC-DC IGBT-based PWM rectifier and a DC-AC IGBT based PWM inverter, with a LCL filter. This filter increase quality of the current.

V. CROW-BAR PROTECTION

A crowbar circuit is an electrical circuit used to prevent an overvoltage condition of a power supply unit from damaging the circuits attached to the power supply. It operates by putting a short circuit or low resistance path across the voltage source, much as if one dropped a tool of the same name across the output terminals of the power supply. Crowbar circuits are frequently implemented using a thyristor, TRIAC.

VI. TRANSFORMER

Wind turbine step-up transformer each equipped with a transformer to step-up turbine generator output voltage to the collector system voltage. This transformer also serves as a source for the turbine's auxiliary power requirement when the turbine is off line or generating insufficient power.

International Journal of Advanced Research in Electrical, Electronics and Instrumentation Engineering

(An ISO 3297: 2007 Certified Organization)

Vol. 4, Issue 1, January 2015

VII. SIMULATION

The given simulation model based on the principle is that a fixed wind speed is consider in this model ,the kinetic energy of wind speed is converted in electrical energy with the help of turbine shaft and PMSG. In this model we used several controller(MPPT controller, PLL controller, Pitch controller, Grid side Inverter controller, Generator side Inverter controller)which help us to send this electrical energy to the National Grid.

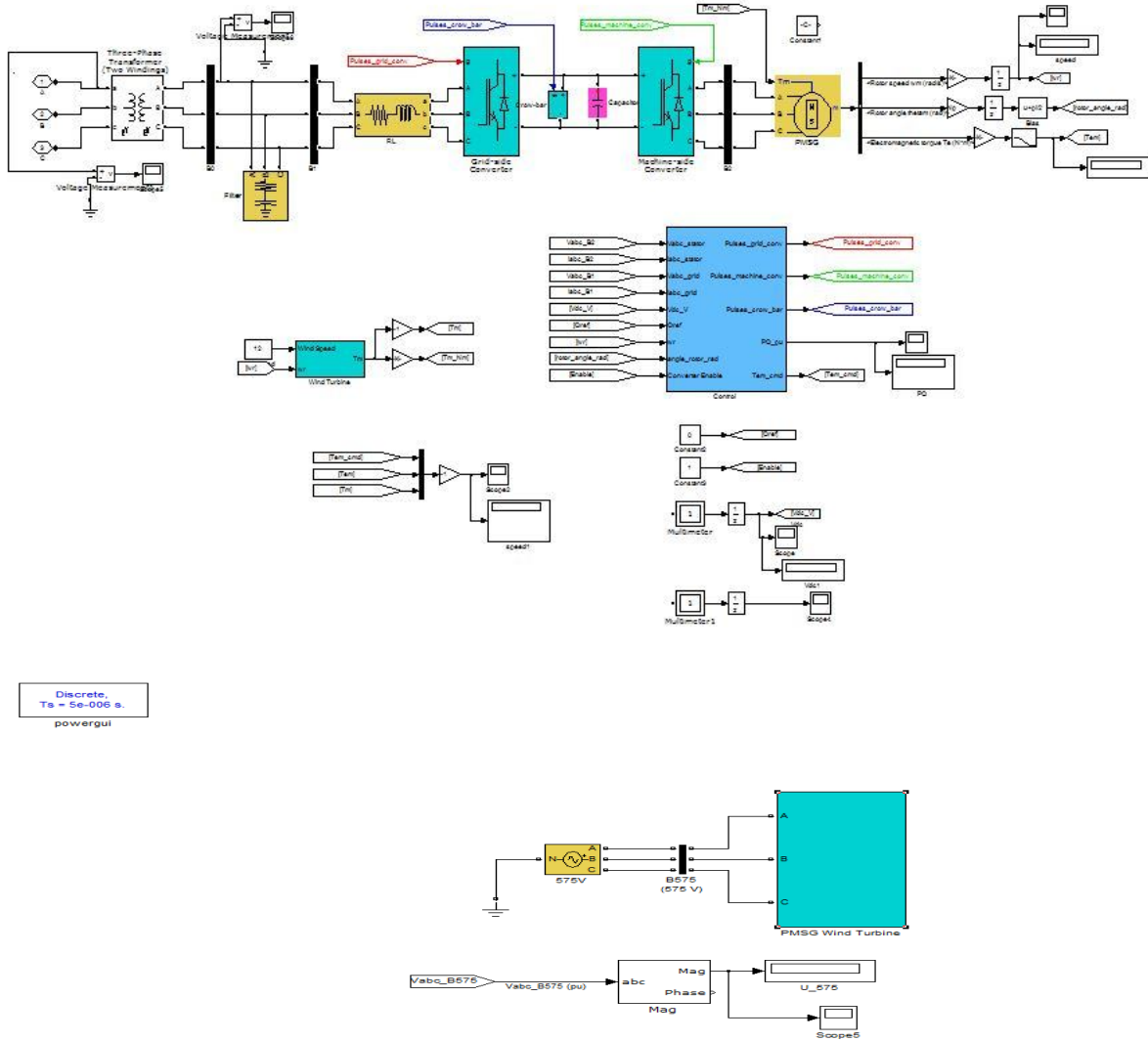

Fig.7. Simulation of wind energy conversion system in MAT LAB

VIII. RESULT

The given simulation Out-put result gives us Rotor speed of wind turbine,wind turbine torque, tubine pitch, Torque(mechanical,electrical,tortional) ,voltage across the capacitor,finally out-put voltage which send to the grid.

International Journal of Advanced Research in Electrical, Electronics and Instrumentation Engineering

(An ISO 3297: 2007 Certified Organization)

Vol. 4, Issue 1, January 2015

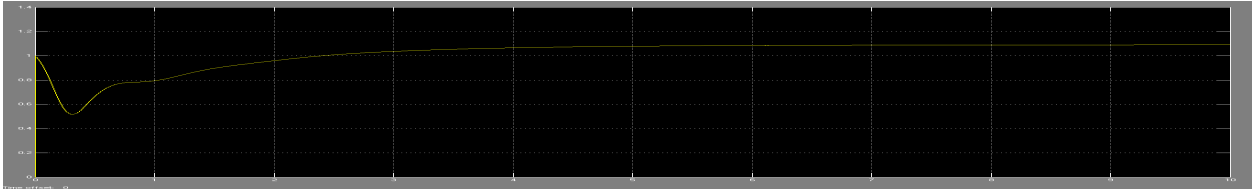

Fig 8.1 Rotor speed of Wind turbine

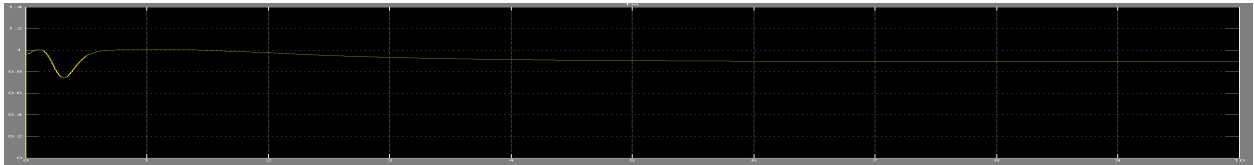

Fig 8.2 wind turbine torque

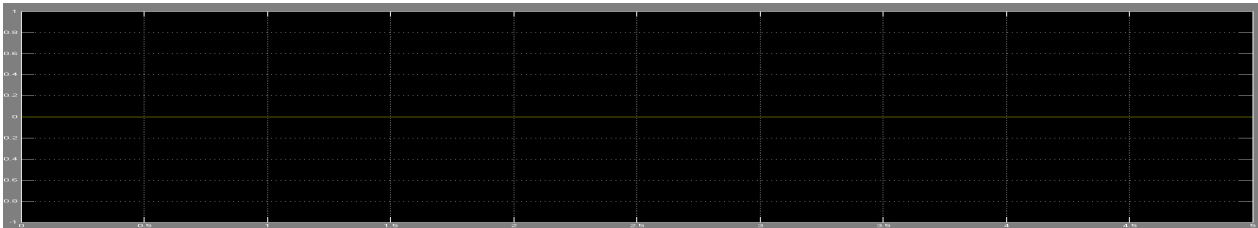

Fig 8.3 wind turbine pitch

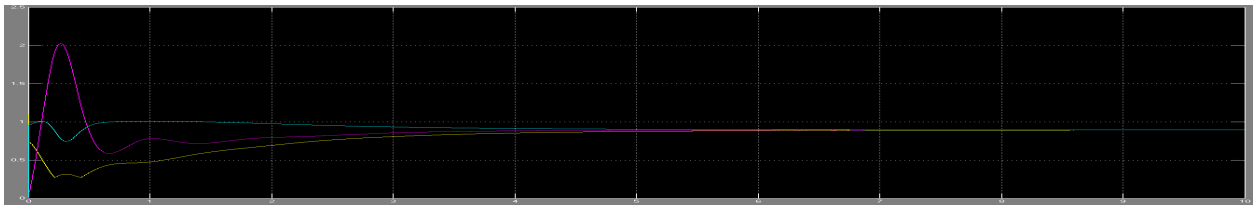

Fig 8. 4 Torque (Mechanical, electrical, torsional)

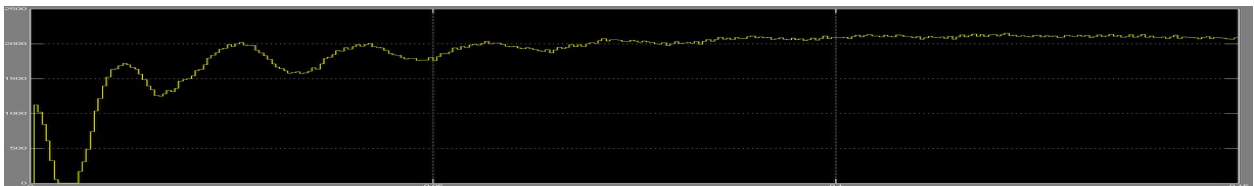

Fig 8.5 Voltage across the capacitor

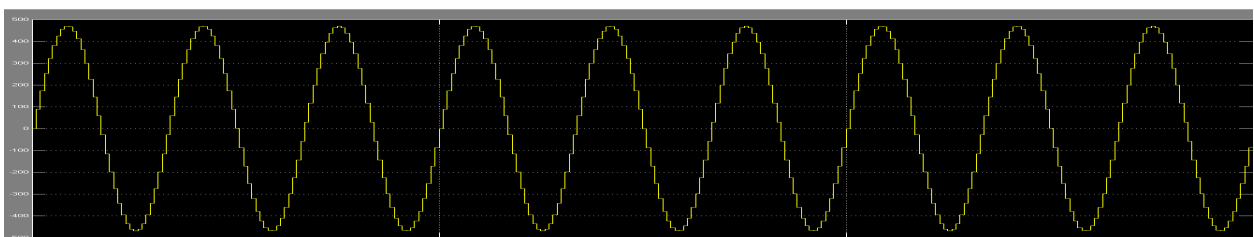

Fig 8.7 Output voltage



International Journal of Advanced Research in Electrical, Electronics and Instrumentation Engineering

(An ISO 3297: 2007 Certified Organization)

Vol. 4, Issue 1, January 2015

IX. CONCLUSION

This study analyzes the control strategies as well as models and designs and simulates the whole autonomous system of PMSG wind turbine feeding AC power to the utility grid in Matlab Simulink . The simulation results show that the combination of pitch angle controller, generator-side inverter controller, and grid-side inverter controller has good dynamic and static performance. The maximum power can be tracked and the generator wind turbine can be operated in high efficiency. DC-link voltage is kept at stable level for decoupling control of active and reactive power. Hence, the output will get the optimum power supply for the grid.

REFERENCES

- [1] Jay Verma, Yogesh , Tiwari, Anup Mishra, Nirbhaya Singh ,”Performance, Analysis and Simulation of Wind Energy Conversion System Connected with grid”. IJRTE, ISSN: 2277-3878 Volume-2, Issue-6, January 2014.
- [2] D Mary, Shinosh Mathew, Sreejith K.,”Modeling and Simulation of Grid Connected Wind Energy System.”, IJSCE, ISSN: 2231-2307, Volume-3, Issue-1, and March 2013.
- [3] A. Bharathi sankar, Dr. R. Seyezhai, ”MATLAB Simulation of Power Electronic Converter for PMSG Based Wind Energy Conversion System”, IJIREICE, Vol.1, Issue.8, November 2013
- [4] Gaurav Singh Bhandari, Dr. M. Kowasly, ”Power Electronics Converter for Grid Integrated Variable Speed Wind Turbine”, IJDR, Vol.4, Issue.3, March 2014
- [5] Rajveer Mittal, K.S. Sandhu, D K. Jain, ”Grid Voltage Control of Inverter Interfaced Wind Energy Conversion System”, IJESD, Vol.2, Issue.5, October 2011.
- [6] J. Chen, H. B. Wu, M. Sun, W. N. Jiang, L. Cai, and C. Y. Guo, “Modeling and simulation of directly driven wind turbine with permanent magnet synchronous generator,” in Proceedings of the 2012 IEEE Innovative Smart Grid Technologies, Asia (ISGT '12), pp. 1–5, May 2012.

BIOGRAPHY



Sourav Ghosh was born in West Bengal, India on January 11, 1987. He received his B.Tech degree in Electrical Engineering from Aryabhata Institute of Engineering and Management, Durgapur, West Bengal in 2010. Currently he is doing M.Tech degree in Power Electronics and Drives from Jalpaiguri Govt. Engineering College, Jalpaiguri, West Bengal.



Prof. Pradip Kumar Saha, Professor, Jalpaiguri Government Engineering College, Jalpaiguri, WB-735102. BE (Electrical) from B.E. College, Shibpore. M.Tech (Electrical) Specialization: Machine Drives & Power Electronics from IIT- Kharagpur. PhD from University of North Bengal. FIE, MISTE, Certified Energy Auditor.



Prof. Goutam Kumar Panda, Professor and Head, Department of Electrical Engineering, Department of Electrical Engineering, Jalpaiguri Government Engineering College, Jalpaiguri, WB-735102, BE (Electrical) from J.G.E. College, Jalpaiguri, M.E.E (Electrical) Specialization: Electrical Machines & Drives from Jadavpur University. PhD from University of North Bengal. FIE, MISTE, Certified Energy Auditor .