

Haptic Feedback for Injecting Biological Cells using Miniature Compliant Mechanisms

V. Mallikarjuna Rao and G.K. Ananthasuresh*

Department of Mechanical Engineering, Indian Institute of Science, Bangalore, India

{malli, suresh}@mecheng.iisc.ernet.in)

*Corresponding author

Abstract

We present a real-time haptics-aided injection technique for biological cells using miniature compliant mechanisms. Our system consists of a haptic robot operated by a human hand, an XYZ stage for micro-positioning, a camera for image capture, and a polydimethylsiloxane (PDMS) miniature compliant device that serves the dual purpose of an injecting tool and a force-sensor. In contrast to existing haptics-based micromanipulation techniques where an external force sensor is used, we use visually captured displacements of the compliant mechanism to compute the applied and reaction forces. The human hand can feel the magnified manipulation force through the haptic device in real-time while the motion of the human hand is replicated on the mechanism side. The images are captured using a camera at the rate of 30 frames per second for extracting the displacement data. This is used to compute the forces at the rate of 30 Hz. The force computed in this manner is sent at the rate of 1000 Hz to ensure stable haptic interaction. The haptic cell-manipulation system was tested by injecting into a zebrafish egg cell after validating the technique at a size larger than that of the cell.

Keywords: cell-manipulation, remote-haptics, vision-based force sensing, and intracytoplasmic injection.

1 Introduction

Haptic feedback or simply “haptics” is the use of sense of touch in a user-interface to provide force information to a user [1]. Although it has been widely used in virtual reality applications [2, 3] such as medical simulation and virtual painting, it has also been effectively applied in tele-manipulation systems for interaction between a slave robot and real deformable object [4-6]. Currently, the reaction force between a remote tool (injecting pipette) and a real object (biological cell) is measured either by using external force transducer or by using visual data of the deformed real object [7-10]. However, these methods have some difficulties such as real-time signal processing, increased system complexity, and inability in accurate modeling of the unknown properties of the real object, which in our case is a biological cell.

Haptic feedback enables evaluation of human fac-

tors in performing the cell-injection. The success rate of manual injection technique is very low, which is attributed to the lack of force feedback [9] when knobs or joystick of injection tools are operated by the user. When injecting into the nucleus of an egg cell, it is important not to inject into the cytoplasm. Hence, the user should know when the cell-membrane is pierced and then when the nuclear membrane is penetrated. Visual information is often not enough and thus warrants the force feedback. In [7], this was done using a polyvinylidene fluoride (PVDF) sensor and a haptic interface. Our work is along the similar lines but with a difference: we do not use an external force sensor; our injecting tool itself doubles up as a force sensor.

Thus, this study entails a cell injection algorithm with haptic feedback (see Fig. 1) based on real-time visual data of the displacement-amplifying compliant mechanism (DaCM) which is used as a force sensor. Since both the visual information and a force sensor (DaCM) are used, we can get the combined advantages and overcome the limitations of both the methods. In order to provide force feedback, a customized image processing algorithm is used to track the displacement measuring edge of the DaCM and thereby estimate the reaction force based on visual information. These estimated forces computed at 30 Hz rate are sent at 1000 Hz update rate for stable haptic feedback. This means that the transmitted haptic force is updated every 1/30th of a second.

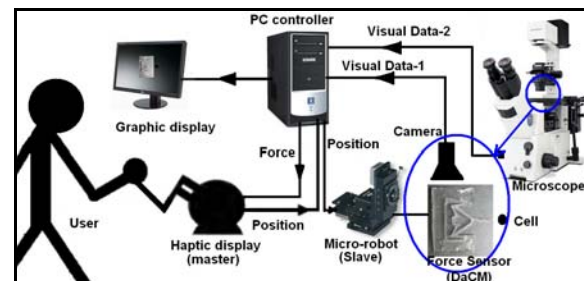

Fig. 1: Conceptual diagram of the cell-injection system with haptic feedback using a displacement-amplifying compliant mechanism (DaCM).

2 Methodology

The cell injection system shown in Fig. 2, comprises a 3-DOF XYZ micro-positioning tool (also called a micro-robot, MP-285, Sutter Inc.), a syringe (SGE Analytical Science) with a tube and pipette attached to a cell, an inverted microscope with 2-DOF motorized positioning stage (IX71, Olympus Inc.), a charge coupled device (CCD) camera (SSC-DC54AP, Sony Inc.), and a complementary metal oxide semiconductor (CMOS) camera (SC-08, Smart Infocomm Pvt. Ltd.) for vision based force-sensing. We use a displacement-amplifying compliant mechanism (DaCM) made in-house with polydimethylsiloxane (PDMS) to measure the cell injection forces. The PDMS material is suitable for our application because of its high compliance and good sensitivity with our force-sensing technique. The glass micropipette is attached to the DaCM using a strong adhesive to realize a firm joint. The DaCM and the CMOS camera are attached to a custom-made holder which intern is attached to the micro-positioning stage (MP-285) so that the whole arrangement forms the cell injecting unit. The micro-robot motion is controlled by a human user through a haptic device (PHANTOM Premium 1.5/6DOF HF, SensAble Technologies Inc.) and a PC controller. The cell injection forces measured using the vision feedback are magnified and are transmitted to the user through the haptic device.

The block diagram for the cell-injection system is shown in Fig. 3. It consists of four loops: haptic loop, micro-robot loop, video loop, and computation loop. The haptic loop helps fetch the position of the haptic device to the personal computer (PC) and sending the calculated force to the user in real-time. The micro-robot loop sends the current position from the PC to the micro-robot in real-time so that the user's motion is replicated on the DaCM side of injection system. The video loop manages to get the video data from the cameras to the PC and then to the display system in real-time. The computation loop performs the image processing to calculate the reaction forces in real-time.

2.1 Design and Calibration of the Force Sensor (DaCM)

A displacement-amplifying compliant mechanism (DaCM) uses the input force applied at one point (input point) to give an amplified displacement at another point (output point). The DaCM was designed based on the methods developed in [11, 12]. Topology, size and shape optimization were used to design the DaCM (see Figs. 4(a-b)). Figure 4(a) shows the geometric model of the mechanism with dimensions, and Fig. 4(b) shows the prototype fabricated in-house using polydimethylsiloxane (PDMS) material using wire-cut electro discharge machined (EDM) aluminium mould and vacuum-casting.

The objective function maximized in topology optimization was the ratio of the displacements at the output and input points subjected to equilibrium equations,

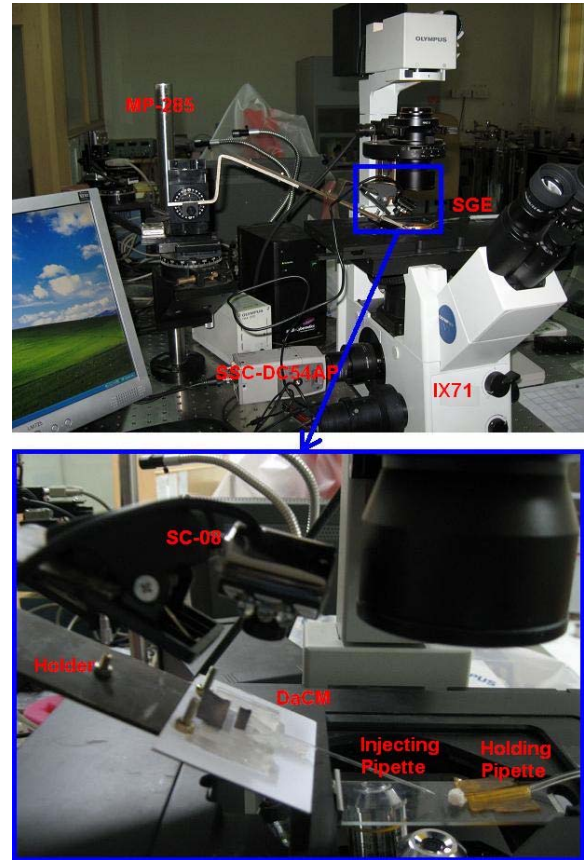

Fig. 2: Experimental setup for cell injection.

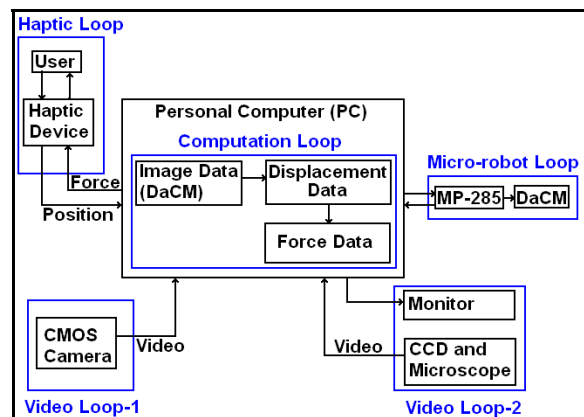

Fig. 3: Block diagram of the cell injection system.

a volume constraint, and upper and lower bounds on the design variables. After obtaining the basic topology from topology optimization, the size and shape optimization was done by keeping in mind the fabrication constraints and the high unloaded output displacement [11]. The objective function for size and shape optimization was the same as the objective function of topology optimization, but the design variables here were the length, orientation and the width of the features of the basic topology. This two-stage optimization helps in getting a design that obeys the manufacturing constraints of wire-cut Electro Discharge Machining (EDM).

Nonlinear large displacement finite element analysis (FEA) was done, using COMSOL MultiPhysics finite element software on the DaCM to calibrate it theoretically. A set of forces ranging from 0 to 1500 μN in steps of 50 μN was applied on the DaCM input point and the displacement of the output point was calculated. The force vs. displacement plot is shown in Fig. 5. This data is used to find out the force value from the displacement value in real-time. The real model of the force sensor (i.e., DaCM) tends to show local buckling when the output displacement exceeds 1 mm. Therefore, the maximum force that can be measured is 1200 μN , which is adequate in the cell-injection task.

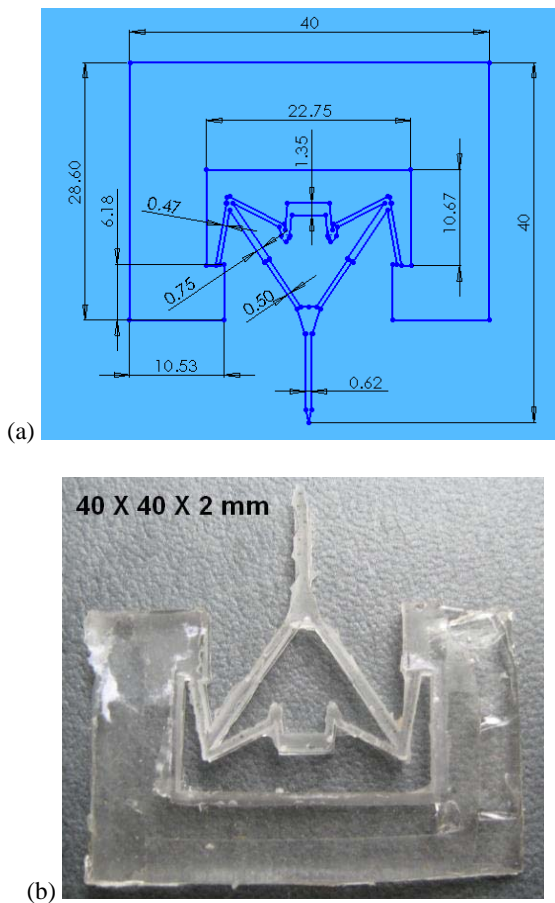

Fig. 4: (a) Topology, shape and size optimized displacement-amplifying compliant mechanism (DaCM), (b) manufactured prototype using polydimethylsiloxane (PDMS) by vacuum casting with a wire-cut aluminium mould. All dimensions in (a) are in mm.

2.2 Vision-based Force-sensing

The displacement of the output point is measured in terms of the number of pixels of the image in real-time by using a customized edge-detection algorithm. This pixel displacement is mapped to find the absolute displacement and then to find the reaction force (see Fig. 6).

The reaction force computed in this manner is updated at a rate of 30 Hz. But for stable haptic rendering, we need the force update rate to be at 1000 Hz. To achieve this requirement, we use a step-wise interpolation. That is, we use the force computed at the time of previous graphic update for all the haptic updates until the new graphic update of force is done. This means, we use the same force computed at 0 ms (first graphic update) for the haptic updates of 0, 1, 2, 3 ... 34 ms (first to 35th update).

With the camera and the setup used, 3 mm of absolute length takes 100 pixels length (i.e., 0.03 mm/pixel). The edge-detection algorithm gives a noise of one pixel because of the variation in image quality from frame to frame. Therefore, the least measurable distance in pixels is two and hence it is 0.06 mm. Consequently, from the force vs. displacement data of the force sensor, the least measurable force is approximately 50 μN .

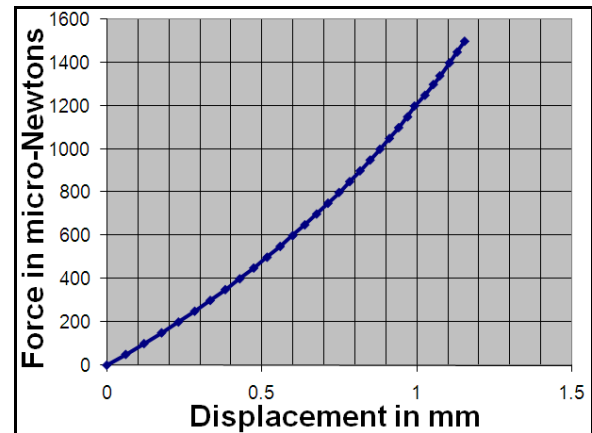

Fig. 5: Force vs. Displacement plot for the force sensor (DaCM).

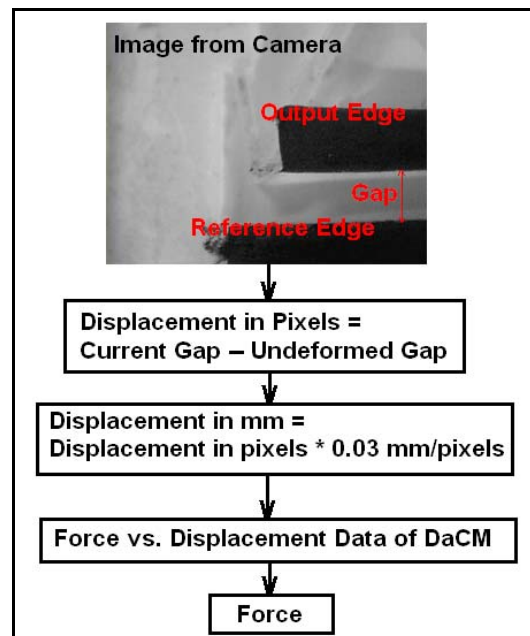

Fig. 6: Block diagram of vision based force sensing.

3 Results

We first validated our method and the setup by working with an object that is much larger than an egg cell of zebrafish and for which there is an independent way to verify the measured force. For this, we chose a spring steel cantilever of 25 mm × 10 mm × 0.2 mm size and set up a test-bed without using the microscope. Since the size of this is large, we used a larger DaCM than the one shown in Fig. 4b for measuring the force. This was made using spring steel on a wire-cut EDM. The setup is shown in Figs. 7(a-b). Figure 7(a) shows the cantilever undeformed because the probe tip of the DaCM is not touching it whereas in Fig. 7(b), we can see that it has deflected. The DaCM was actuated by the XYZ stage (MP 285) as per the hand-movement of the user holding the haptic device. We verified the force estimated by the DaCM agreed with that given by the deflection formula of the cantilever.

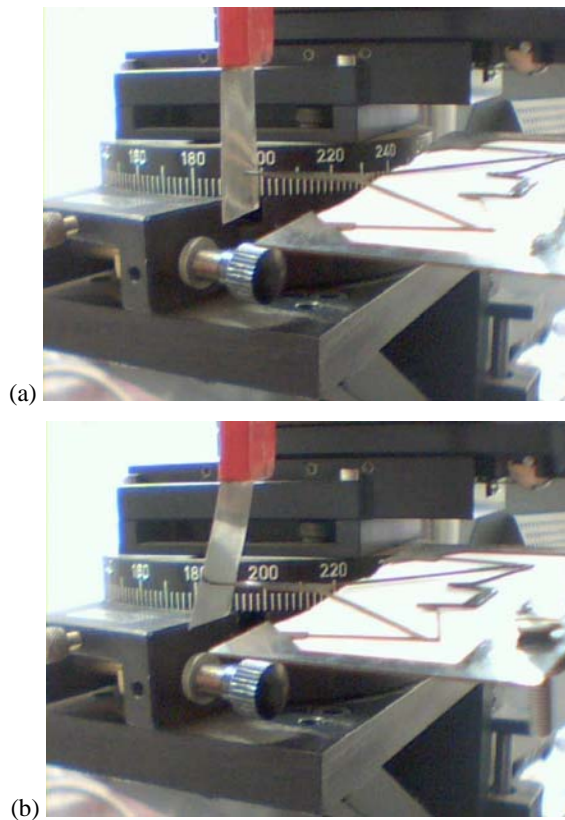

Fig. 7: Macro-scale experiment for validating the remote haptics technique with a spring-steel cantilever. (a) just before touching, (b) after deformation.

We then performed experiments (see Fig. 8), on zebrafish egg cells to test our injection system. The injecting pipette with the holding arrangement is moved by a user through the haptic device and the forces experienced by the injecting pipette are felt by the user through the same haptic device. A scaling factor of 1/30 is used for the distance-mapping and 10,000 for force-mapping between macro and micro environments; this means that when the user moves the haptic probe

by 30 units of distance, the micro-robot and holder arrangement moves by one unit; and when the actual force is one unit, the user feels 10,000 units of force through the haptic device. The plot of the measured force vs. the displacement of the micro-positioning stage is shown in Fig. 9. Since the egg cell was taken from zebrafish at the early stage of its cell growth, they were very soft and resulted in a maximum measured force of 100 μN only.

The experiment described above demonstrated cell-injection but it damaged the cell as can be seen in the E and F stages of Fig. 8. However, it confirms the effectiveness of our method. The reason for damage of the cell was not a consequence of the methodology; it was simply because the diameter of the needle used was quite large. When we used a fine needle (see Fig. 10), we were able to gently penetrate the cell. But we could not inject with it due to the lack of a pump that can provide the pressure needed for injection through a fine needle. Procuring a peristaltic pump and performing successful injection and extensive experimentation are currently in progress.

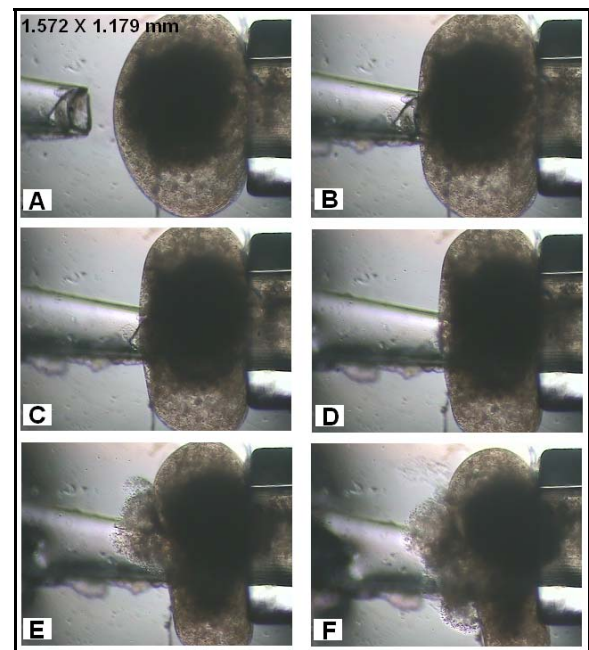

Fig. 8: An example of zebra fish cell injection using compliant mechanism as a force sensor and injector with haptic feedback.

(A) Injecting pipette is approaching the cell.

(B) Injecting pipette touched the cell.

(C) Cell is deformed.

(D) Injecting pipette is still moved forward by user.

(E) Cell membrane is punctured.

(F) Inner contents of the cell are coming out.

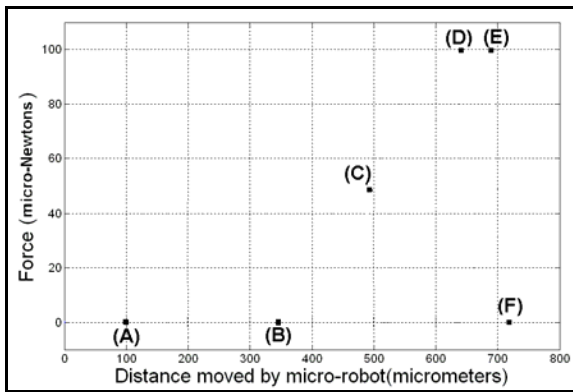

Fig. 9: Plot of measured force vs. distance moved by micro-positioning stage. (A) to (F) are the stages of Fig. 8.

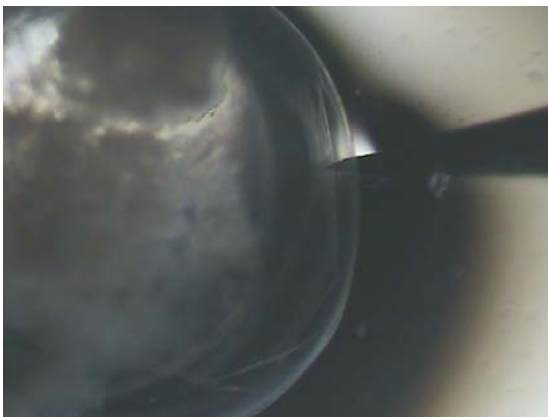

Fig. 10: A zebra fish egg cell pierced gently using a fine needle.

4 Closure

We demonstrated the real-time cell injection with haptic feedback. A novel method of force-sensing is used with haptics. Using this setup, the cell injection can be done more effectively as it provides visual and force feedback in real time. Systematic evaluation of the success rate using extensive testing and adding haptic feedback for cell-grasping are part of our ongoing work. The motivation for the latter is that vacuum-gripping using pipettes (as was done in this and other works) could potentially damage the cell. Our rationale for using a compliant mechanism for force-sensing (as opposed to an external force sensor) is that the same can also be used for grasping and thus provide force-feedback in grasping delicate and flexible objects such as the cells and embryos.

Acknowledgments

The authors would like to thank Ramu, Vinod and Ravi for their help in fabrication of grippers. This work is supported in part by the Swarnajayanthi fellowship of the Department of Science and Technology (DST), Government of India, to the second author as well as the Math Biology grant from DST.

References

- [1] Mandayam, A.S., and Basdogan, C., "Haptics in Virtual Environments: Taxonomy, Research Status, and Challenges," *Computers and Graphics*, Vol. 21, No. 4, 1997, pp.393-404.
- [2] Salisbury, J.K., and Mandayam, A.S., "Phantom-Based Haptic Interaction with Virtual Objects," *IEEE Computer Graphics and Applications*, Vol. 17, No. 5, 1997, pp.6-10.
- [3] Vivek, N.H., "Interactive Haptic Rendering," Master of Engineering Project Report, Department of Mechanical Engineering, Indian Institute of Science, 2007.
- [4] J. Park and O. Khatib, "A haptic teleoperation approach based on contact force control," *International Journal of Robotics Research*, vol. 25, 2006, pp. 575-591.
- [5] Basdogan, C., De, S., Kim, J., Muniyandi, M., Kim, H., and Mandayam, A.S., "Haptics in minimally invasive surgical simulation and training," *IEEE Computer Graphics and Applications (IEEE CG&A)*, March/April 2004, pp.56-64.
- [6] Okamura, A.M., "Methods for haptic feedback in teleoperated robot-assisted surgery," *Industrial Robot: An International Journal*, Vol. 31, No. 6, 2004, pp. 499-508.
- [7] Pillarisetti, A., Pekarev, M., Brooks, A.D., and Desai, J.P., "Evaluating the Effect of Force Feedback in Cell Injection," *IEEE Transactions on Automation Science and Engineering*, vol. 4(3), 2007, pp. 322-331.
- [8] Jungsik Kim, Youngjin Kim, and Jung Kim, "Real-time haptic rendering of slowly deformable bodies based on two dimensional visual information for telemanipulation," *International Conference on Control, Automation, and Systems*, October 17-20, 2007, pp.2448-2451.
- [9] Yu, S. and Nelson, B.L., "Autonomous Injection of Biological Cells using Visual Servoing," in *Experimental Robotics VIII*, LNCIS 271, D. T\us and S. Singh (eds.), 2001, pp. 169-178.
- [10] Wang, W., Liu, X., Gelinias, D., Ciruna, B., and Sun, Yu, "A Fully Automated Robotic System for Microinjection of Zebrafish Embryos," *PLoS ONE*, www.plosone.org, Sep. 2007, Issue 9, e862.
- [11] Sahu, D.K., "Topology Optimization and Prototyping of Miniature Complaint Grippers for Micromanipulation," Master of Engineering Project Report, Department of Mechanical Engineering, Indian Institute of Science, 2008.

- [12] Krishnan, G. and Ananthasuresh, G. K., "A Systematic Method for the Objective Evaluation and Selection of Compliant Displacement Amplifying Mechanisms for Sensor Applications," *Journal of Mechanical Design*, Volume 130, Issue 10, 2008, pp. 102304:1-9.