



PERGAMON

Planetary and Space Science 48 (2000) 1087–1091

**Planetary  
and  
Space Science**[www.elsevier.nl/locate/planspasci](http://www.elsevier.nl/locate/planspasci)

## MOD: an organic detector for the future robotic exploration of Mars

G. Kminek<sup>a</sup>, J.L. Bada<sup>a,\*</sup>, O. Botta<sup>a</sup>, D.P. Glavin<sup>a</sup>, F. Grunthaler<sup>b</sup><sup>a</sup>*Scripps Institution of Oceanography, 9500 Gilman Drive, La Jolla, CA-92093-0208, USA*<sup>b</sup>*Jet Propulsion Laboratory, 4800 Oak Grove Drive, Pasadena, CA-91109, USA*

Received 27 September 1999; received in revised form 17 December 1999; accepted 7 February 2000

### Abstract

Searching for extinct or extant life on Mars is part of the future NASA surveyor class missions. Looking for key organic compounds that are essential for biochemistry as we know it or indicative of extraterrestrial organic influx is the primary goal of the Mars Organic Detector (MOD). MOD is able to detect amino acids, amines and PAHs with at least 100 times higher sensitivity than the Viking GCMS experiment. MOD is not capable of identifying specific organic molecules but can assess the organic inventory of amines and PAHs on the planet. MOD can also quantify adsorbed and chemisorbed water and evolved carbon dioxide in a stepped heating cycle to determine specific carbon-bearing minerals. All that comes with no sample preparation and no wet chemistry. The organics can be isolated from the carrier matrix by heating the sample and recovering the volatile organics on a cold finger. This sublimation technique can be used for extracting amino acids, amines and PAHs under Mars ambient conditions. The detection of amino acids, amines and PAHs is based on a fluorescence detection scheme. The MOD concept has functioned as a laboratory breadboard since 1998. A number of natural samples including shells, clays, bones,  $\lambda$ -DNA and *E.-coli* bacteria have been used and organic molecules have been extracted successfully in each case. The first prototype of MOD is operational as of early fall of 1999. MOD has been selected for the definition phase of the NASA-MSR 2003 mission. © 2000 Elsevier Science Ltd. All rights reserved.

### 1. Introduction

In the search for evidence of either extinct or extant life on Mars, the detection of organic compounds is considered to be of fundamental importance. Carbon-based polymers such as nucleic acids and proteins make up the core molecules required to carry out critical biological functions, including replication and catalysis. Without these functions, life as we know could not exist. Thus, the exploration of Mars for possible signs of life has to focus on key organic molecules. Although we have Martian samples for direct analysis in the form of SNC's on Earth, terrestrial contamination of these meteorites often leads to ambiguous results (see Bada et al., 1998; Glavin et al., 1999). Until we bring Martian samples under controlled conditions back to Earth, in situ measurements, like what we will do with MOD, are the only way to get unaltered samples for analysis. This will also provide us with a reference level for the returned samples.

The search for organics on Mars is by no means a new idea. The Viking landers GCMS was looking for organics on the surface and subsurface to about 20 cm depth. The surprising result from Viking was the failure to detect organics at the ppm levels for methane and ppb levels for complex organics (see Klein, 1979). Since the infall of meteorites and interplanetary dust should be carrying organics to Mars at a rate of over  $10^5$  kg/yr (see Chyba and Sagan, 1992), their absence in the Martian soil suggests that they are being actively destroyed.

Despite the negative results, it is possible that organics are present on the Martian surface at levels below the detection limit of the Viking GCMS, or that organics are preserved in the Martian subsurface beneath the depth that Viking was able to access. The deeper layers are supposed to be protected from the surface oxidants that are most likely the major mechanism for destroying organics. However, the depth profile of these oxidants is not known and may well be beyond the means of robotic exploration (see for an overview Zent, 1998).

The Mars Organic Detector (MOD) has been designed to detect key organic compounds in rock and soil samples in order to assess whether organic compounds, possibly

\* Corresponding author. Tel.: +1-858-534-2995; fax: +1-858-534-2674.

E-mail address: [jbada@ucsd.edu](mailto:jbada@ucsd.edu) (J.L. Bada).

associated with life, are present on Mars. MOD has a detection limit for the target compounds which is at least two orders of magnitude more sensitive than the Viking GCMS.

Any organic compounds that will be found on Mars are of interest independent of their pre-biotic, exogenous or biological origin. The organic compounds targeted by MOD are native fluorophores (PAHs) and amines.

Amino acids are the building blocks of proteins and play an essential role in biochemistry. They are, therefore, well suited as biomarker for extinct or extant life. In addition, over 70 different amino acids have been identified in carbonaceous meteorites, many of which have been produced in pre-biotic synthesis experiments (see Miller, 1953). While it is not certain that a Martian biology would use amino acids, their ubiquity as constituents of organic material in the solar system suggests that they would have been available for incorporation into protobiochemical systems on Mars just as they were on Earth. Amino acids degrade to amines via decarboxylation.

PAHs have no known role in biochemistry on Earth, although they can be produced from combustion or long-term decomposition of biologically derived organic compounds. PAHs, however, appear to be widespread throughout the Universe and have been identified in carbonaceous meteorites and the interstellar medium (see Léger et al., 1987). PAHs would probably be more resistant to destruction during impact delivery on Mars than amino acids and other organic compounds. The detection of PAHs could provide an indication of the delivery of meteoritic organic material to Mars. MOD is capable to detect amino acids, amines and PAHs at the sub-picomole level.

The MOD design also includes a Tunable Diode Laser Spectrometer (TDLS) with which it will be possible to quantify the extent of adsorbed and chemically bound water and carbon dioxide in the surface and subsurface, and to evaluate the size of these reservoirs relative to the Martian atmosphere. There are two primary reservoirs of water in the regolith that will be accessible to human explorers. Water can be either adsorbed onto soil particle surfaces or chemically bound within hydrated minerals. Adsorbed water, which can be easily removed with moderate heating, is of great interest for in situ resource utilization concepts. The detection of carbon dioxide will make it possible to identify carbon-bearing minerals. The sample will be heated to several different temperature setpoints and the evolved carbon dioxide at specific temperatures can be used to infer the carbon-bearing minerals (e.g. siderite, magnesium carbonate and calcite). The carbonate composition of ALH84001 could be readily detected by MOD.

All measurements made by MOD are quantitative because the samples mass will be evaluated using a strain gauge. The major advantage of MOD, however, is the absence of wet chemistry in combination with its small size, low power and housekeeping requirements.

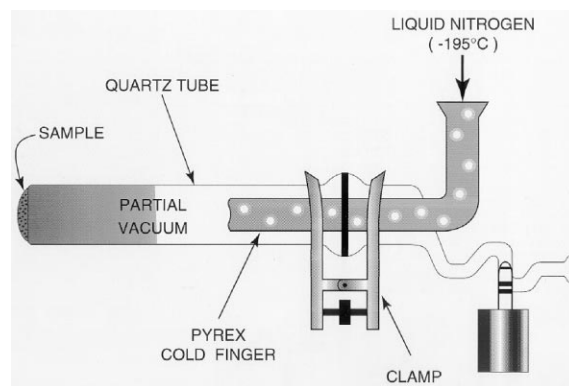

Fig. 1. MOD breadboard sublimation apparatus. The apparatus is made out of a pyrex cold finger and a quartz tube. The sample is placed on the bottom of the quartz tube before it is connected to the pyrex cold finger and sealed. The whole assembly is connected to a vacuum line until the pressure is less than 500–600 mTorr. After that, the sublimation assembly is inserted into a heater. Heating time is usually 1–5 min at 450°C. Liquid nitrogen has to be supplied during the heating to cool the cold finger.

## 2. MOD breadboard design

The MOD breadboard design is limited to the organic detector. The TDLS will be implemented in the first MOD prototype.

The basic principle to isolate the organics from the sample is by means of sublimation (see Glavin and Bada, 1998). This method is based on the fact that certain organics have appreciable vapor pressures at temperatures greater than 150°C. To demonstrate the use of sublimation for extracting organic compounds directly from natural samples, we have carried out a number of experiments that have resulted in a breadboard version of the MOD instrument. In the MOD breadboard, organic compounds are directly sublimed from the sample — thereby eliminating the need for complex wet chemical extraction. The sample (0.1–1 g) is heated under partial vacuum (500–600 mTorr) to 450°C in a closed chamber (see Fig. 1). For maximum organic recovery, the rock sample should be crushed or powdered. The heating time varies from 1 to 5 min. The sublimed material is captured on a liquid-nitrogen cooled cold finger which is a part of the vacuum vessel. The captured sublimed material is dissolved in water and analyzed using high-performance liquid chromatography (HPLC). The recovery is very much dependent on the mineral matrix. Pure amino acids can be sublimed with recoveries up to 100% with no decomposition to amines (see Glavin and Bada, 1998). The behavior of amino acids in fossil mollusk shells is more complex than the pure amino acid mixture. The recovery of intact amino acids can be less than 1% with extensive decomposition to amines by amino acid decarboxylation. The amines, however, can still be readily detected using the same methodologies used for amino acid detection. Thus, even when the amino acid decomposition is significant, MOD can detect the decomposition products,

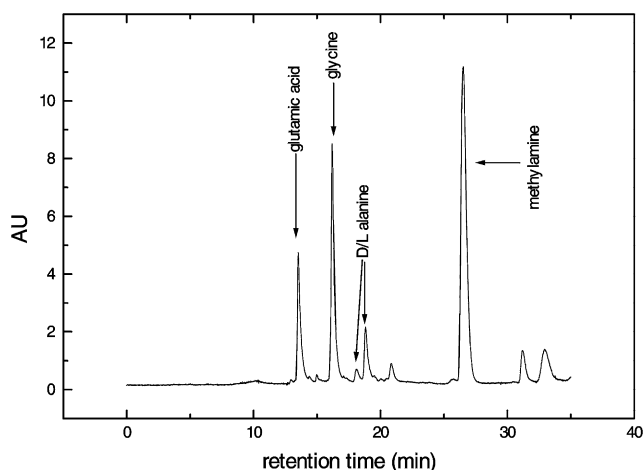

Fig. 2. HPLC analysis of a sublimed human bone sample. The bone powder was sublimed at 300°C for 5 min. No additional sample preparation has been carried out. Clearly visible are at least three amino acids and some decomposition products (methylamine). The signal is corrected for blank level. Bone sample has been provided by M.P. Evison, Department of Forensic Pathology, The University of Sheffield, UK.

so the presence of amino acids in the original sample can be inferred. Because MOD is not going to look for the enantiomeric ratios of the amino acids, the decomposition to amines (which are not chiral) is not a great loss of information. The recovery of amino acids from clays and human bones tend to be close to 30% (Kminek, unpublished data, see Fig. 2). The sublimation method can be used to isolate amino acids, amines, purines, pyrimidines and PAHs under the same conditions, at the same time. All these organics have been isolated from different samples and the procedure is used in the laboratory on a daily base.

Although the sublimed organic material is analyzed using HPLC in the laboratory breadboard version, an important aspect of our sublimation approach is that the target compounds (amino acids, amines and PAHs) can be detected with high sensitivity directly on the tip of the cold finger using fluorescence-based methods. Fluorescamine is used as a fluorescent tag for amino acids and amines, while PAHs are naturally fluorescent. The excitation wavelength of products of fluorescamine and primary amines is 390 nm; the emission wavelength is at 475 nm. Experiments indicate that the fluorescamine reaction proceeds rapidly in the dry state at room temperature; there is no solvent necessary for the reaction to take place (O. Botta, private communication). A mixture of amino acids sublimed on a cold finger coated with fluorescamine under standard sublimation conditions yields easily detectable fluorescence (see Fig. 3). Visual observation shows that the reaction proceeds slower than in solution and requires the cold finger to warm up to at least 0°C. If the concentration of amino acids in a Martian sample is in the ppb range, the sublimation of 1 g of sample would yield amounts of amino acids/aminers that are well within the detection limit of the MOD.

The detection of sublimed PAHs can be carried out directly on the cold finger without the need for a fluorescent reagent (see Fig. 3). PAHs are readily fluorescent when excited with near-UV light. The detection limit is in the sub-femtomole range. Experiments with a standard mixture of amino acids and PAHs were carried out using a hand-held Hg lamp and a commercially available digital camera. The cold finger was coated with fluorescamine only on one side. About  $10^{-9}$  mol of amino acids were easily detectable using no filters and image enhancement.

### 3. MOD technical implementation — the MOD prototype

The first MOD prototype will be ready in early fall of 1999. This first prototype will include all the key components of the flight hardware: sublimation and fluorescence detection and the TDLS (see Fig. 4). The MOD prototype will undergo extensive testing during fall/winter of 1999. The pyrolytic boron nitride crucible with the integrated pyrolytic graphite heater is a key new technology of the MOD design. The crucible/heater design has been a standard in the high-purity molecular beam epitaxial (MBE) growth of semiconductors. The sampling area of the heated chambers is isolated from the transport zone by an aperture plate to keep dust particles away from the detector area. The cold finger detector zone is thermally isolated from the oven with a sealed insulated jacket and is maintained at the low ambient Martian temperature during the sublimation sequence. The cooling is satisfied with passive cooling fins and an appropriate thermal mass. The cold finger contains a two-zone detection plate. One half of the detector is covered with fluorescamine, while the other half is left uncoated. The cold finger will be equipped with several identical two-zone detection plates for multiple sample runs. The reaction on the detector plate occurs after the sublimation heaters are turned off and the detector substrate is heated to 20°C. Fluorescence is stimulated by a set of high-efficiency GaN light-emitting diodes that will illuminate the detector substrate through a band pass filter transmitting photons at 385 nm. The fluorescence emission of the condensed compounds will be detected by a low-noise photodiode quadrature detector viewing the substrate through a low-pass 450 nm filter for amines and an additional filter in the 530 nm range for medium-weight PAHs.

The MOD prototype will include a TDLS design that has been developed for the MGS'98 MVACS experiment (for more information on TDL see Webster et al., 1988, 1990). A multipass Herriott cell will be part of the TDLS to increase the pathlength and hence the sensitivity of the TDLS. A purge gas capability is incorporated to reduce background levels and to support oxygen introduction for total carbon analysis. The TDLS will operate at 1.37  $\mu\text{m}$  for water and 2.05  $\mu\text{m}$  for carbon dioxide.

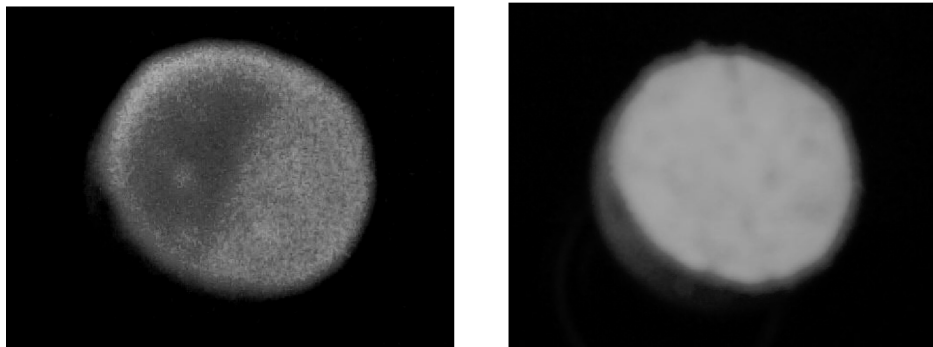

Fig. 3. Fluorescence signal of amino acids and PAHs directly on the cold finger. The left picture shows half of the cold finger (right half) coated with fluorescamine and the sublimed amino acid standard. The fluorescent signal of the amino acids is clearly visible on the coated part of the cold finger. The greenish color around the cold finger is reflected light from the Hg lamp. The right picture shows the bright fluorescent signal of a PAH standard. Both pictures were taken with a commercial digital camera (Kodak DC200). The fluorescence has been excited with a hand-held Hg lamp. No additional filters or image enhancements were used.

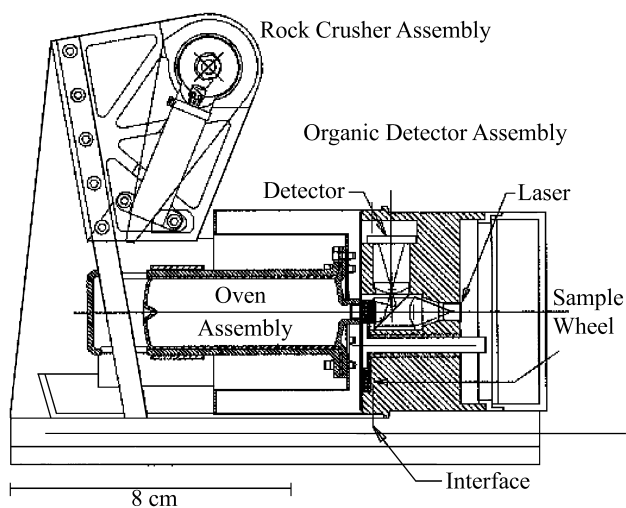

Fig. 4. MOD prototype design. The total mass of the MOD, including the rock crusher is 2300 g. The sample (0.1–1 g) can be introduced through the introduction port of the rock crusher (in case of solid cores) or directly into the sublimation zone inlet. Drawing provided by C. LaBaw, NASA-JPL.

The time line for an experiment will start with moderate heating to detect adsorbed water and continue with heating steps from 300 to 900°C to sublime organics (at lower temperatures) and to measure chemically bound water and evolved carbon dioxide to identify carbonates.

MOD is not a stand-alone instrument. There is an obvious need to acquire samples from the Martian surface/subsurface. The samples can be either powder or rocks (for which a rock crusher can be provided). No further sample preparation step is necessary before dropping the sample into the MOD unit. MOD is therefore an ideal instrument as part of an exobiology package or sample acquisition system with minimal requirements for sample handling and preparation. Because of its small volume, weight and housekeeping requirements, it can be easily accommodated and maintained. MOD will be integrated in the Italian IPSE payload

for the NASA-MSR 2003 definition phase and receive samples from the LBS (Lander-Based Sampler, deep drill).

#### 4. Conclusion

Using sublimation to isolate, and fluorescence to identify certain organic molecules makes the MOD a very useful, simple and reliable instrument. Although MOD is not able to identify specific organic molecules, a concept based on MOD but improved by microchip capillary-electrophoresis is under study as part of the Grand Challenge Initiative of NASA. This extended MOD-CE version will be able to identify individual organic molecules and their chirality. Nevertheless, MOD has a certain degree of specificity for the target compounds. The combination of readily sublimable organics and the quantum efficiency of the fluorescence process excited with near-UV light and emission wavelength for the fluorescamine/primary amine addition product (450 nm filter) and a wavelength filter for medium-weight PAHs makes these signatures quite unique. Concerns regarding chemical reactions of the hydrazine propellant of the lander descent engines and the fluorescamine will be addressed in further laboratory experiments. In addition to the detection of organic molecules, which is of great interest for the origin of life community, the MOD can also quantify the water reservoir in the Martian near-surface regolith. Since water is a key resource for the future human exploration of Mars, this specific ability places the MOD in line with the NASA-HEDS initiative. The detection of evolved carbon dioxide from samples during stepped heating cycles will make it possible to identify specific carbon-bearing minerals. Altogether the MOD, being a single instrument, offers three crucial data sets — quantification of the inventory of organic molecules for exobiology, assessment of the water inventory for in situ resource utilization and identification of certain carbon-bearing minerals.

## Acknowledgements

The MOD has been developed and funded under the Planetary Instrument Definition and Development Program (PIDDP), the Mars Instrument Development Program (MIDP) of NASA and the NASA Specialized Center of Research and Training in Exobiology at the Scripps Institution of Oceanography. Most of the work presented in this paper is based on the work of the MOD-team: Diana L. Blaney (NASA-JPL), Siamak Farouhar (NASA-JPL), Rebecca Heninger (NASA-JPL), Mark Herring (NASA-JPL), Clayton LaBaw (NASA-JPL), Colin Mahoney (NASA-JPL), Gene McDonald (NASA-JPL), Orin Serviss (NASA-JPL), Eric Slimko (CALTECH), Christopher R. Webster (NASA-JPL) and Robert Richter (NASA-JPL).

## References

- Bada, J.L., Glavin, D.P., McDonald, G.D., Becker, L., 1998. A search for endogenous amino acids in Martian meteorite ALH84001. *Science* 279, 362–365.
- Chyba, C., Sagan, C., 1992. Endogenous production, exogenous delivery and impact-shock synthesis of organic molecules: an inventory for the origin of life. *Nature* 355, 125–132.
- Glavin, D.P., Bada, J.L., 1998. Isolation of amino acids from natural samples using sublimation. *Anal. Chem.* 70, 3119–3122.
- Glavin, D.P., Bada, J.L., Brinton, L.F., McDonald, G.D., 1999. Amino acids in the Martian meteorite Nakhla. *Proc. Natl. Acad. Sci.* 96, 8835–8838.
- Klein, H.P., 1979. The Viking mission and the search for life on Mars. *Rev. Geophys. Space Phys.* 17 (7), 1655–1662.
- Léger, A., d'Hendecourt, L., Boccara, N. (Eds.), 1987. *Polycyclic Aromatic Hydrocarbons and Astrophysics*. Vol. 191. NATO ASI Series C.
- Miller, S.L., 1953. A production of amino acids under possible primitive earth conditions. *Science* 117, 528.
- Webster, C.R., Menzies, R.T., Hinkley, E.D., 1988. Tunable diode laser IR spectrometer for in-situ measurements of the gas-phase composition and particle-size distribution of Titan's atmosphere. In: Measures, R.M. (Ed.), *Laser Remote Chemical Analysis*. Wiley, New York (Chapter 3).
- Webster, C.R., Sander, S.P., Beer, R., 1990. *Appl. Opt.* 29, 907–917.
- Zent, A.P., 1998. On the thickness of the oxidized layer of Martian regolith. *J. Geophys. Res.-Planets* 103(E13), 31 491–31 498.