

## The Effect of Organizational Justice and Perceived Organizational Support on University Staff Job Burnout (Case of University Staff of Isfahan)

<sup>1</sup>Ali Safari, Ph.D., <sup>2</sup>Maryam TamiziFar, B.S., <sup>3</sup>Ali Reza Jannati, M.A

<sup>1</sup>Assistant Professor, Management Department, University of Isfahan, Iran.

<sup>2</sup>Management Department, University of Isfahan, Iran.

<sup>3</sup>Management Department, University of Isfahan, Iran.

---

**Abstract:** One of the problems human resource managers encounter nowadays is the job burnout phenomenon. This can even happen in universities and cause a decline in work efficiency and a failure to reach long-term purposes. This study aims at manifesting the job burnout state and the effect of organizational justice and perceived organizational support on job burnout staff of the University of Isfahan who are working in administrative sections. The data gathering tools consist of three standard questionnaires for perceived organizational justice, organizational support and job burnout assessment which are administered among a sample of 150 individuals out of 448 staff working in administrative sections of the University of Isfahan. The volume of the sample is also calculated by stratification using Cochran formula. By using of structural equation modeling (SEM) method, it can be said that organizational justice and perceived organizational support has a negative effects on job burnout, but perceived organizational support doesn't significantly affect on job burnout.

**Key words:** organizational justice, perceived organizational support, job burnout, the University of Isfahan.

---

### Introduction

Nowadays the most important properties of an organization are not its machinery and equipment, but its efficient, motivated, undertaken and enthusiastic human sources; therefore organizations should pay more attention to their human sources than their machinery. With regard to the importance of human resources, job burnout phenomenon is one of the most important issues which exist in most organizations. This is considered as a destructive factor to organizations, because lots of individuals can lose their efficiency due to job burnout and stop flourishing.

Job burnout is an organizational behavior factor that can prevent from flourishing and utilizing human resources and cause job quitting, absence and production decline (Boles *et al.*, 2000). Staffs who suffer from job burnout are less motivated and less active. They are psychologically indifferent, depressed, exhausted and fractious. They nag about their entire environment and even their colleagues and react negatively to others' suggestions, so their work quality decreases hugely (Sadeghi, 2002). Therefore, job burnout may not show its effects at the first stage, but its effects are clearly visible by studying staff and organization's efficiency. In today's world, human resource managers tend more to identify the roots of job burnout and decrease it as much as possible.

According to the studies conducted, organizational justice can play an important role in developing staff job burnout, i.e. inexistence of organizational justice can cause staff job burnout (Kroon *et al.*, 2009; Noblet & Rodwell 2008). In addition to this factor, organizational support and staff's perception of organizational support can also prevent job burnout and in case of inexistence of organizational support, this becomes a factor in causing job burnout (Aiken *et al.*, 2001; Kwak *et al.*, 2010). Based on this, the current study is to explore the effects of organizational justice and perceived organizational support on job burnout of staff working in administrative sections of the University of Isfahan which is a quite functional environment. After exploring job burnout, organizational justice and perceived organizational support, the study hypothesis of the desired pattern have been designed and then by considering structural equations modeling (SEM), the role of organizational justice and perceived organizational support in developing job burnout has been specified.

### Review of literature:

Job burnout phenomenon has been a matter of concern for management, psychology and science specialist. It involves a psychological process which occurs under a great deal of professional stress and it shows itself through emotional exhaustion, depersonalization, motivation decline and decreased personal accomplishment. Emotional exhaustion is a feeling of depression, inability and inefficiency and shows itself by some symptoms like pessimism about others, mistrust, querulous and suspicious about the honesty of others (Clark, 1998). Depersonalization is a cruel and unfair response to those who are usually receiving some services

from him. It also refers to the person's negative interpretation of the staff. Motivation decline and decreased personal accomplishment also cause the person to lose his sufficiency feeling in doing personal duties.

This is considered a negative evaluation of the self in doing a task as well. Several studies have been conducted about job burnout and factors affecting it. Each of these studies has found a group of factors influencing. In a study by Kwak *et al.* (2010), perceived organizational support had a great effect on job burnout and job burnout had a big effect on job satisfaction. In a study by Raymond *et al.* (2006), emotional exhaustion played an important role in job burnout and factors like life satisfaction, job satisfaction and the amount of working hours spent with subordinates had a direct relationship with emotional exhaustion. Clark's study (1998) on 112 senior and junior managers concluded that one fifth of the managers had a high job burnout; the individuals' demographics have no effect on their job burnout. In a study by Rahim (1995), 328 company founders and 288 managers had been studied for job burnout; company founders who had a higher control on their work, suffered less from job burnout compared to managers.

According to the studies done, it can be said that several intra- and extra-organizational factors have been effective on staff job burnout and several factors are effective in causing it in an organization. Therefore lots of factors should be taken into account in order to study this phenomenon. According to the review of literature and studies conducted, both organizational justice and perceived organizational support have a great impact on job burnout; this study will also explore these two factors.

The term "organizational justice" was first used by Browning *et al.* in 1970s. Quoted from Greenburg, Fernandes and Awamleh state that organizational justice involves distributional justice, procedural justice and interactional justice (Fernandes and Awamleh, 2006). Distributional justice is originated from Adams' equality theory and deals with equity perceived from consequences. Distributional justice is considered as a potential factor with some important applications in organizational context (Yochi & Spector, 2001). It should be noticed that distributional justice is not limited to fair payment, but it includes a wide range of organizational consequences such as raises, gratuities, punishments, work schedules, job advantages and performance evaluations (Folger & Cropanzano, 1998). From the beginning of 1980s, issues related to procedural justice was also taken into account (McDowall & Fletcher, 2004). From this point of view, justice should be defined by use of fair procedures. This means that fair decisions are those which are the outcomes of fair procedures (Wendy, 2007). Among procedural justice principles, some issues such as dispassionate, the right to express oneself, the chance to be heard and involvement in decision making can be referred to (Nabatchi *et al.*, 2007). At the beginning of 1990s, the concept of interactional justice took the attention of organizational justice researchers. Interactional justice refers to the quality of interpersonal behaviors which an individual is exposed to it before and after decision making (Wendy, 2007). Several studies have been conducted in recent years about the relationship between organizational justice and job burnout. In a study about the relationship between organizational justice (procedural justice) and job burnout on 86 Dutch organizations, Kroon *et al.* (2009) concluded that an inverse relationship exists between organizational justice and job burnout. Noblet & Rodwell (2008) have conducted a study about the effects of organizational justice and specifically procedural justice on job burnout which the results show an inverse relationship between organizational justice and job burnout. This is so in a way that as organizational justice (and specially procedural justice) increases, job burnout decreases. Schminke *et al.* (2000) have also concluded in another study that in the presence of organizational justice, professional stress level will decrease job burnout level and job burnout will go under a remarkable decline. Therefore, as organizational justice increases, job burnout decreases. Thus based on the review of literature and studies conducted in this area, the first hypothesis can be stated as below:

**Hypothesis I:**

Organizational justice has a negative effect on job burnout

In 1986, Eisenberger *et al.* introduced the concept of organizational perceived support by publishing an article in "Practical Psychology" magazine. According to the definition given by Eisenberger *et al.* (1986), staff will feel support from organization when organization values them for their cooperation and pays attention to their welfare. Although studies done in this area were few up to the middle of 1990s, they have increased in recent years (Eisenberger 2004). The theoretical basis of organizational support is the theory of social interaction. Based on this theory, in a social relationship when a person does another one a favor, he considers it as a must to compensate the other's favor. The greater the favor, the more motivation the person have to compensate. Researchers believe the same social interaction exists between employees and employers, as the organization is a source to supply employees' needs; therefore interactional relationship between employees and employers is true. Organizational support theory states that staff form a general view about the amount of organizations' support for them, and in response to this support, they regard for organization's aims and achieving them. In other words when the organization pays attention to staff's welfare, the staff will compensate it by more commitment and better performance (Eisenberger *et al.*, 2001). Social interaction theorists believe the value of interactional relationships will increase when it is done voluntarily. When the staff feel that the organization pays attention to their welfares on its own, and not due to some legal requirements and union

forces, they better respond to it and move better towards achieving organization's goals(Eisenberger *et al.*, 1997). In addition to this, the organization is considered as a source of satisfying some of staff's social requirements such as their identification, dependency needs and self esteem. Therefore to keep the source of satisfying their needs, the staff help organization achieve its goals(Eisenberger *et al.*, 1990). In a general categorization, previous studies can be classified into two categories. The first category involves studies which have investigated preliminaries of perceived support. In these studies, perceived support is a dependent variable, and whatever causes the staff to feel the development of support will be identified and explored. That is to say, only those actions of organization have been investigated in these studies that cause staff to feel organization's support. The second category involves those studies which have investigated consequences of perceived support. In these studies researchers have tried to show that what positive effects support of staff will have on job burnout and that if perceived organizational support exists, job burnout will decrease.

Results of the studies in the first category have shown that three actions done by organization cause staff think they are supported; or the support they are receiving from organization has increased. These actions involve organizational justice (Shore & Shore, 1995), superordinate support (Stinglhamber & Vandenberghe, 2003) and organizational and working conditions (Stinglhamber, & Vandenberghe, 2006). Justice in distributing organizational sources, specially justice in distributing sources that aims at welfare aspects of staff, has also a great impact on their perception of the amount of organizational support. Previous studies have also shown that some other factors such as various gratuities, working conditions like income, rise of job security, working optionality, stressful factors and training influence the increase or decrease of staff's perceived support. That to what extent the superordinate values his staff's cooperation and pays attention to their welfare has a great impact on the staff's viewpoint about the support they feel from organization. Sometimes the staff consider superordinate's direct support from them as the organization's, i.e. they generalize superordinate's support to that of organization. Therefore as shown in the studies, superordinate's support plays an important role in developing staff's perceived support. Thus the second assumption is made in this way:

**Hypothesis II:**

organizational justice has a positive effect on perceived organizational support

The results in second category show that perceived support by organization has beneficial consequences in both individual and organizational level for organizations. Therefore as also pointed in a study by Aiken *et al.* (2001), perceived organizational support has a negative effect on job burnout and as perceived organizational support increases, job burnout decreases. Kwaket *al.*'s (2010) study also shows that perceived organizational support has a negative effect on job burnout. Other studies demonstrate that social and organizational support perceived by staff is effective in job burnout reduction (Garrosa *et al.*, 2010; Emold *et al.*, 2010; Awa *et al.*, 2010; Thanacoody *et al.*, 2009). Thus the third hypothesis is stated as below:

**Hypothesis III:**

perceived organizational support has a negative effect on job burnout.

Based on stated hypothesis, it can generally be supposed that the desired pattern shows the relationship between organizational justice, perceived organizational support and job burnout. The desired pattern can be shown in figure 1.

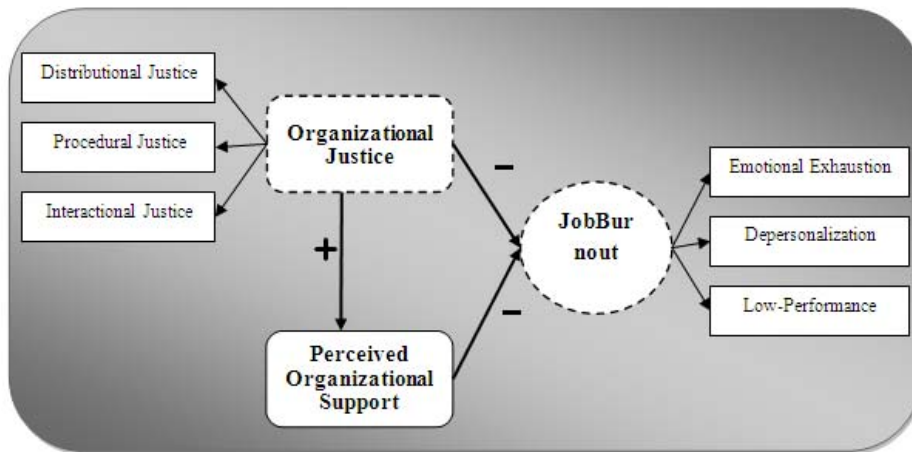

**Fig. 1:** Desired pattern in the study

**Methodology:**

The present study is purposefully practical and methodologically descriptive-survey from a scopebranch. The following standard questionnaires have been used to collect and analyze data: Price & Mueller's questionnaire for distributional justice, Moorman's for interactional and procedural justice, Eisenberger *et al.* (1986) for perceived organizational support and Clarke's (1998) for job burnout. The Cronbach alpha coefficient value for each questionnaire is stated below:

organizational justice=0.89, perceived organizational support=0.86, job burnout= 0.90

All organizational staff working in different administrative sections of the University of Isfahan was involved in our study; the statistical population of our study has been 448 individuals. Stratified sampling method is appropriate to the statistical population, in a way that a population of 150 individuals has been specified by initial pilot study of population, basic calculations and using Cochran's formula for calculating population; then sampling was done in proportion to each class of staff working in different administrative sections of the University of Isfahan. One hundred percent of the questionnaires were returned to be investigated. "Amos 18" program has been used to process the extracted data from the questionnaires, and structural equation modeling (SEM) has been used in order to investigate the study hypothesizes.

**Result:**

The initial model for the study was not confirmed after calculating SEM by "Amos 18". The initial unconfirmed SEM is shown in figure 2.

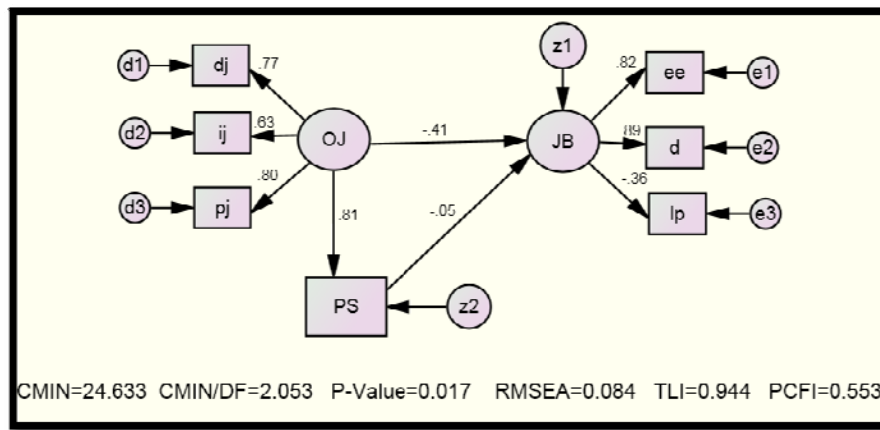

**Fig. 2:**Unconfirmed SEM

OJ= Organizational Justice, dj=Distributional Justice, ij= Interactional Justice, pj=Procedural Justice, PS=Perceived Organizational support, JB=Job Burnout, ee=emotional exhaustion, d=depersonalization, lp=low-performance

As it is shown in figure 2, the appropriate fitness value of the model is not accepted and the model needs to be modified. Therefore as regression weight related to low-performance is not significant, by removing this variable from the model the desired SEM is confirmed. The confirmed model is shown in figure 3.

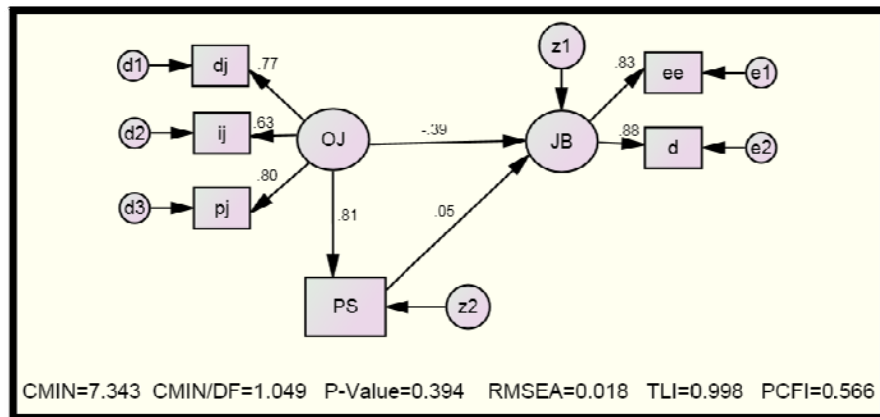

**Fig. 3:** Confirmed SEM

Regression weights and the effect size of each of the variables in confirmed SEM are presented below:

**Table 1.** regression weights of confirmed SEM

Relationships between variables	Assessment
organizational justice → job burnout	- 0.394
perceived organizational support → job burnout	-0.054
organizational justice → perceived organizational support	0.811
organizational justice → distributional justice	0.769
organizational justice → interactional justice	0.630
organizational justice → procedural justice	0.802
job burnout → emotional exhaustion	0.832
job burnout → depersonalization	0.832

According to goodness-of-fit indexes, the SEM has an appropriate fitness and all indexes are in accordance with specified standards.

**Table 2:** goodness-of-fit indexes in the pattern

Index Type	Indexes	Standard index	Value index in model	Result
Absolute	CMIN	---	7.343	Goodness of fit
	Value-P	more than 0.05	0.394	Goodness of fit
Comparative	TLI	more than 0.9	0.998	Goodness of fit
	CFI	more than 0.9	0.999	Goodness of fit
Parsimonious	RMSEA	less than 0.05	0.018	Goodness of fit
	CMIN/DF	less than 5	1.049	Goodness of fit
	PCFI	more than 0.5	0.566	Goodness of fit
	PNFI	more than 0.5	0.558	Goodness of fit

According to table (2) and acquired indexes, it can be concluded that fitness model is appropriate and staff working in administrative sections of the University of Isfahan are affected by a significant organizational justice of -0.394 and a non-significant perceived organizational support of -0.054. This means that if organizational justice increases, the staff's job burnout will decrease by thirty nine percent.

**Conclusion and Suggestions:**

Based on studies conducted relevant to the present study and also hypothesis tested, the following results can be acquired and proper suggestions can be presented.

Based on hypothesis I, organizational justice exists among staff working in administrative sections of the University of Isfahan in three conditions of distributional justice, interactional justice and procedural justice; this also has a negative impact on job burnout of the staff working in administrative sections of the University of Isfahan with a coefficient of -0.394. This result is in accordance with results of studies by Kroon *et al.* (2009), Noblet and Rodwell (2008), Schminke *et al.* (2000). Thus it is suggested to superior management and human resources management of the University of Isfahan to sustain the current level of organizational justice, they try to increase it as well; this way, they can increase job satisfaction and improve their efficiency and also decrease the job burnout level of the staff in order to lessen job quitting, staff absence and other negative reactions resulted from job burnout.

Bases on testing hypothesis II, organizational justice has a positive impact on perceived organizational support and as the organizational justice increases, perceived organizational support also increases with the rate of 0.811; this amount implies the huge effect of organizational justice on perceived organizational support. This result is in accordance with Shore & Shore's (1995) study. Therefore it is suggested to human resources managers of the University of Isfahan to raise organizational justice in order to reinforce perceived organizational support as much as possible.

Based on hypothesis III, even though perceived organizational support has an effect of -0.054 on job burnout, this impact is not significant and these two variables are independent of each other. Results in testing this assumption are not in accordance with studies stated in review of literature. It is suggested, therefore, to human resources management of the University of Isfahan to develop a significant relationship between the two variables of organizational support and helping human resources and provide a context of decreasing staff's job burnout by increasing organizational support and helping human resources in order to better understand organizational support.

**REFERENCES**

Aiken, L.H., S. Clarke, D. Sloane, J. Sochalski, R. Busse, H. Clarke, P. Giovannetti, J. Hunt, A. Rafferty, & J. Shamian, 2001. Nurses' reports on hospital care in five countries. *Health Affairs*, 20(3): 43-53.  
 Awa, L.W., M. Plaumann, & U. Walter, 2010. Burnout prevention: A review of intervention programs. *Patient Education and Counseling*, 78: 184-190.

- Boles, J.S., D.H. Dean, & J.M. Ricks, 2000. The dimensionality of the Maslach burnout inventory across small business owners and educators, *Journal of Vocation Behavior*, 56: 12-34.
- Browning, L., C.S. Ryan, M.S. Greenberg, S. Rolniak, 2006. Effects of cognitive adaptation on the expectation-burnout relationship among nurses. *Journal of Behavioral Medicine*, 29: 139-150.
- Clark, R., 1998. Burnout and associated factors among Administrators/Mid-Managers of Cooperative Extension service in the north central region. Ohio State University, Columbus. Dept of agricultural education. Report.
- Eisenberger, R., J.R. Jones, J. Aselage and I.L. Sucharski, 2004, "Perceived organizational support", in Coyle-Shapiro, J.A.-M., Shore, L.M., Taylor, M.S. and Tetrick, L.E. (Eds), *The Employment Relationship: Examining Psychological and Contextual Perspectives*, Oxford University Press, New York, NY, pp: 206-25.
- Eisenberger, R., S. Armeli, B. Rexwinkel, P.D. Lynch and L. Rhoades, 2001, "Reciprocation of perceived organizational support", *Journal of Applied Psychology*, 86(1): 42-51.
- Eisenberger, R., J. Cummings, S. Armeli, P. Lynch, 1997. Perceived organizational support, discretionary treatment and job satisfaction, *Journal of Applied Psychology*, 82(5): 812-820.
- Eisenberger, R., R. Huntington, S. Hutchison and D. Sowa, 1986. "Perceived organizational support", *Journal of Applied Psychology*, 71: 500-7.
- Emold, C., N. Schneider, I. Meller, & Y. Yagil, 2010. Communication skills, working environment and burnout among oncology nurses. *European Journal of Oncology Nursing*, Article in Press.
- Fernandes, C. & R. Awamleh, 2006. Impact of organizational justice in An expatriate work environment. *Management Research News*, 29(11): 701-712.
- Folger, R & K. Cropanzano, 1998. *Organizational Justice and Human Resource Management*, New York: Sage Publications.
- Garrosa, E., C. Rainho, M.B. Jimenze, & J.M. Monteiro, 2010. The relationship between job stressors, hardy personality, coping resources and burnout in a sample of nurses: A correlational study at two time points. *International Journal of Nursing Studies*, 47: 205-215.
- Kwak, C., Y.B. Chung, Y. Xu, & E.C. Jung, 2010. Relationship of job satisfaction with perceived organizational support and quality of care among South Korean nurses: A questionnaire survey. *International Journal of Nursing Studies*, Article in Press.
- Kroon, B., K. van de Voorde and M. van Veldhoven, 2009. "Cross-level effects of high-performance work practices on burnout Two counteracting mediating mechanisms compared". *Personnel Review*, 38(5): 509-525.
- McDowall, A. & C. Fletcher, 2004. Employee development :An organizational justice perspective. *Personnel Review*, 33(1): 8-29.
- Nabatchi, T., B.B. Lisa, & H.G. David, 2007. Organizational justice and workplace mediation: a six-factor model. *International Journal of Conflict Management*, 18(2): 148-174.
- Noblet, A.J. and J.J. Rodwell, 2008. The relationship between organisational justice and job stress: insights, issues and implications, in Houdtmont, I. and Leka, S. (Eds), *Occupational Health Psychology: European Perspectives on Research, Education and Practice*, Nottingham University Press, Nottingham, pp: 281-312.
- Rahim, M.A., 1995. Alouprarative Study Of entrepreneurs and mangers strain, burnout. Locus of control and Social Support, *Health & Human Survey Adm.*, 18(1): 68-79.
- Raymond, T.L., & E.A.A. Blake, 2006. Examination of managerial burnout. *Journal of Organizational Behavior*, 14(1): 3-20.
- Sadeghi, A., 2003. A Survey on Job burnout and its Relation to Public Health of Razi Psychiatric Hospital Staff, M.A. dissertation, Allameh Tabatabaee University.
- Schminke, M., M.L. Ambrose and R. Cropanzano, 2000 "The effect of organizational structure on perceptions of procedural fairness", *Journal of Applied Psychology*, 85: 294-304.
- Shore, L.M. and T.H. Shore, 1995. "Perceived organizational support and organizational justice", in Cropanzano, R.S. and Kacmar, K.M. (Eds), *Organizational Politics, Justice, and Support: Managing the Social Climate of the Workplace*, Quorum, Westport, CT, pp: 149-64.
- Stinglhamber, F., D. De Cremer, L. Mercken, 2006. Perceived support as a mediator of the relationship between justice and trust. *Group Organ Manage*, 31(4): 442-68.
- Stinglhamber, F. and C. Vandenberghe, 2003. "Organizations and supervisors as sources of support and targets of commitment: a longitudinal study", *Journal of Organizational Behavior*, 24(4): 251-70.
- Thanacody, R.P., T. Bartram, & G. Casimir, 2009. The effects of burnout and supervisory social support on the relationship between work-family conflict and intention to leave: A study of Australian cancer workers. *Journal of Health Organization and Management*, 23(1): 53-69.
- Youchi, C.C., & E.P. Spector, 2001. The role of justice in organizations: A meta Analysis. *Organizational Behavior and Human Decision Processes*, 86(2): 278-321.
- Wendy, L.P., 2007. Organizational Justice as a Framework for Understanding Union-Management Relations in Education. *Canadian Journal of Education*, 30(3): 725-748.