

Progress and Recent Trends in the Torsional Vibration of Internal Combustion Engine

Liang Xingyu, Shu Gequn, Dong Lihui, Wang Bin and Yang Kang
*State Key Laboratory of Engines, Tianjin University, 300072
P. R. China*

1. Introduction

With modern machinery industry developing, the application of internal combustion engine is getting wider and research direction is towards high-power, high speed and strong loads. So the issue of torsional vibration of the engine is becoming more prominent. All kinds of work conditions of the engine may have great impacts on the shafting, leading to all sorts of torsional vibration and resonance, and many accidents which lead to much detriment have occurred at home and abroad due to torsional vibration.

As the problem of torsional vibration of the engine is becoming more and more prominent, broad research is made both at home and abroad. This article mainly refers to the literatures on torsional vibration issue published in recent years, summarizes on the modeling of torsional vibration, corresponding analysis methods, appropriate measures and torsional vibration control, and points out the problems to be solved in the study and some new research directions.

2. Modeling of engine crankshaft

2.1 Engine crankshaft modeling method

Crankshaft is the main component of internal combustion engine. Shaft vibration is one of the most important factors affecting engine operation safety. Crankshaft modeling is the base of crankshaft torsional vibration analysis, whose accuracy and simple practical applicability will greatly improve the efficiency and credibility of research results.

At present, there are 3 kinds of most basic shaft models used in analyzing torsional vibration: the first type is simple mass - spring model, the second is continuous mass model, and the third is multi-segment concentrated mass model.

2.1.1 Simple mass - spring model

Simple mass - spring model is the earliest mechanics model in the calculation of shaft vibration [1-6], which was also called lumped parameter model in some literatures. It disperses crankshaft onto the disk with concentration of inertia moment, elastic axis without mass, internal damping and external damping, as shown in figure 1. Each disk rotational inertia includes: the rotational inertia of the crank, the equivalent rotational inertia of connecting rod and piston, transmission system, shock absorber, the rotational inertia of the flywheel, etc.

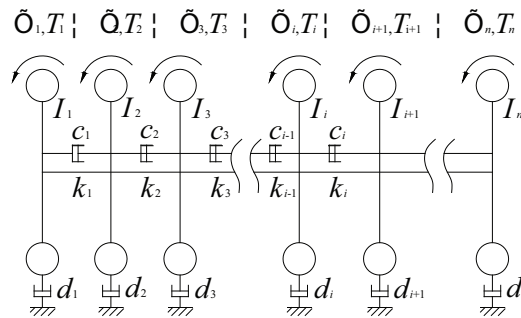

Fig. 1. Simple mass - spring model schematic diagram

This model has certain precision for lower frequency of torsional vibration modal and clear physical concept. It's simple to use and easy to calculate. But since this model is simplified, when precise calculation of the crankshaft is required, its precision is limited. This model is established completely for rigid shaft and rotation parts, so it can not simulate the actual shaft.

2.1.2 Continuous mass model

Continuous mass model is based on continuum theory, regarding shaft as elastomer, established in finite element method. It's also called distributed mass model in some literatures [7-8]. It adopts finite element method in general, dissecting the crankshaft entities directly into finite element calculation model of division. Hence, the mass of the shaft is distributed continuously along the shaft, closer to practice than that of simple mass - spring model. Partial differential equations can be used in this model, which can accurately calculate low frequency and vibration model of the shaft, as well as high frequency and vibration model, solve by numerical method, and also can calculate arbitrary section stress conveniently. But the model is complex and with low speed to calculate, and is easy to cause greater accumulative error. It is more difficult to use this model in system simulation and design. Due to the method of forced vibration calculation, it is hard to realize, thus it's mainly used in the calculation of free vibration.

Recently, two consecutive quality models also have derived from this model: framework model and multi-diameter model.

Framework model is a model, in which, circular cross section straight beam represents main journal and crank pin, and variable cross-section rectangular beam represents crank arm and counterbalance in finite element analysis [9]. For these analyses, circular cross section beam also can represent main journal and crank pin, but the crank arm and counterbalance should be treated as simple rectangular beam. Model schematic diagram is shown in figure 2. In framework model, different structural parts of the crankshaft are substituted by the continuous entities with regular shape, and the original basic shapes of crankshaft are kept. Thus this model has higher precision to analyze the crankshaft vibration.

Multi-diameter model is a model used in elastic wave propagation theory solving torsional vibration of internal combustion engine [10-12]. Assign piston-rod additional mass to two crank arms and simplify a unit crankcase into a group of concentric multi-diameter. Model schematic diagram is shown in figure 3. Because the model has continuous mass

distribution, the effect of distribution parameters on shafting vibration characteristics can be considered. It also can adopt different mathematical methods to calculate and compare with simple mass - spring model. This model can have high precision.

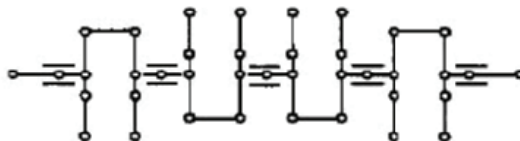

Fig. 2. Framework model schematic diagram

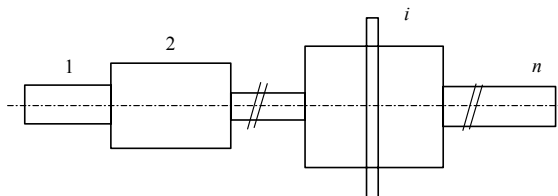

Fig. 3. Multi-diameter model schematic diagram

2.1.3 Multisegment concentrated mass model^[13]

This model is similar to the simple mass model in essence. However, it can be separated into dozens to hundreds sections according to the structure characteristics upon analysis demand. It can calculate high order torsional vibration frequencies that can't be determined by simply mass model, and also avoids the large amount of computation that required in the calculation of continuous mass model. Thus it has been widely used.

2.1.4 Soft body dynamics model^[14]

In the calculation of flexible multi-body dynamics, flexible body is described as modal flexible body. A flexible body contains a series of modals. In the breakdown steps, each model unit requires obtaining system state variables and calculating the relative amplitude of each characteristic vector, then using linear superposition principle to integrate node deformation of each time step to reflect total deformation of flexible body.

2.1.5 Other axis modeling methods

In recent years, with the further study of shafting vibration, many new modeling methods came up in the engine industry and other related industries.

Continuous beam model was used in the crankshaft load calculation by Li Renxian^[15]. The crank and conrod were equalized to the concentrated force acting on a non-equal continuous beam, and all kinds of force were also equalized to simplify. The author analyzed various loads of crankshaft and its changes in an operation cycle comprehensively. This is a simplified model force shown in figure 4. Of course, in order to calculate simply, the author treats both gas load and centrifugal force function load as concentrated loads. If they were expressed as some forms of distributed loads, the calculation might be more accurate. Calculation model may also adopt continuous beam to make it more close to the actual situation of crankshaft.

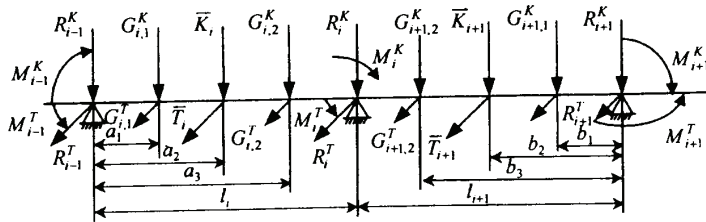

Fig. 4. Continuous beam model schematic diagram

Gu Yujiong^[16] used the four-terminal network model in calculating torsional vibration. The author starts with motor control equations and its general solution, equalizing torsional vibration system to the four-terminal network model based on the principle of electromechanical analogy; then adopts mechanical impedance method to obtain frequency equation controlling torsional vibration according to the input impedance of the system and the resonant characteristics, and then obtains the natural frequency, vibration mode and stress distribution, etc. of each order. Four-terminal network model is an accurate low-order model, whose algorithm is convenient and fast. The physical significance is obvious to analyze the mechanical impedance of the system, thus it is a good attempt to model torsional vibration. He Shanghong and Duan Jian^[17] also used network method in calculating torsional vibration, and based on dynamic in the process of modeling, which was also a kind of deepening of the method.

Through the analysis of different vibration mathematical models, Xiang Jianhua^[18] proposed a graphical modeling method based on system matrix method solving the axis of torsional vibration. The modeling method only requires users providing original torsional vibration mechanics model, and is not restricted by axis branches and modeling scale. In actual implementation, torsional vibration module is divided into two kinds of module unit in this method, which can be used to build various kinds of torsional vibration mechanical model. Model topology relation can be generated through the module traverse and equalisation conversion of the torsional vibration model, and finally the system integration required for solution is integrated.

2.2 Axis modeling research direction

Thanks to the development of modern computer, the precise calculation for shaft can be easily realized by finite element method. So for the continuous mass model, the main development direction is how to make the model have better simulation with material object in computer modeling, thus to peer analysis of the model to material object.

, As the model parameters (especially rigidity parameters) of a simple mass - spring model are obtained by a large number of experience formula and approximate calculations, as its accuracy is hard to ensure, resulting in rather great error between calculated results and actual machine test results. The reason that theoretical calculation result has larger error is often not because of the calculation method of itself, but lies in the accuracy of the model. Since rotational inertia has a relatively accurate analytic calculation, and the torsional vibration damping of the axis is small, to improve the accuracy of the models, focus should be on the amendment of rigidity parameters. Multi-segment concentrated mass model also has similar problem.

The establishment and derivation of a new model should be based on the amendment with material object, adopting all kinds of similar models used in other industries to derive, thus further perfect engine crankshaft torsional vibration model. The influence of damping should not only be considered, the influence of bending-torsional mixture should also be taken into account. Now, many scholars apply model reduction method [19] used in dealing with torsion vibration of steam turbine and generator as well as the method [20] used in identifying parameters of experimental data to the calculation of the engine torsional vibration. This is also the evitable trend of torsional vibration integration.

3 Solving method of torsional vibration of internal combustion engine

3.1 Common method of Torsional vibration

Based on the above-mentioned several shaft models, the common methods and algorithms solving torsional vibration for multi-freedom free vibration calculation include Holzer method, system matrix method and transfer matrix method, etc. The methods for multi-freedom forced vibration calculation include energy method, amplification coefficient method and system matrix method, etc. With the development of computer technology, the traditional manual calculation has been replaced by computers gradually, while some common calculation methods of torsional vibration emerged, such as modal analysis method and finite element method, etc. Various methods are described below.

3.1.1 Holzer method.

Holzer method [1, 2] is always a classic and effective solution in “free- free” system of power machine. The Holzer form method or the Tolle form method derived from its basic principle are often used in engineering. The Holzer method, widely used today, is a numerical calculation method and corresponding calculation program derived from its principle. The advantage of this method is clear physical concept.

From its scientific name, this method can be called “method of sum of torsion moments”. The basic idea is: the sum of inertia moment of each lumped mass (disc) should be zero when the shaft doing free vibration without damp, that is

$$\sum I_k \ddot{\phi}_k = 0$$

Due to the characteristics of simple harmonic oscillator, the relation between the displacement α_k and the acceleration $\ddot{\phi}_k$ of each inertia I_k is:

$\ddot{\phi}_k = -p^2 \alpha_k$, namely, $\sum I_k p^2 \alpha_k = 0$. This is the foundation of Holzer method.

This method is effective in estimating low order torsional vibration frequency in initial design stage. This method has simple algorithm and is easy to use, thus is widely used in actual engineering. But its higher-order calculation has lower precision and is time consuming.

3.1.2 System matrix method

System matrix method [1, 2, 21] is a method using each parameter matrices of torsional vibration equation of the axis to solve characteristic root to calculate torsional vibration. All methods which can calculate the eigenvalue and eigenvector of the matrix can be used to calculate the free torsional vibration of multi-mass system.

The basic principle of this method is: for more freedom vibration equation: $\mathbf{I}\ddot{\varphi} + \mathbf{K}\varphi = 0$ by assuming the form of solution and input them into equation, the following can be obtained: $\mathbf{K}\mathbf{A} = \omega_n^2 \mathbf{I}\mathbf{A}$ let $\lambda = \omega_n^2$ and $\mathbf{H} = \mathbf{I}^{-1}\mathbf{K}$, now the system matrix of $W_M = W_C$ can be obtained. So free vibration calculation can come down to the question of solving characteristic equations $|\mathbf{D}| = 0$.

System matrix method is widely used, not only in free vibration solution, but also in the solution of forced vibration. However, it's generally only suitable for solving low frequencies and its accumulative error would be bigger for calculating high frequencies.

3.1.3 Transfer matrix method

The transfer matrix method [16,22] is a commonly used method for analyzing various vibration problems, which was first introduced by Holzer to analyze crankshaft vibration and calculate the inherent frequency of undamped-free vibration of the shafting.

The basic concept of transfer matrix method is: decomposing the studied system into several two-terminal elements with simple mechanical properties, and building relation between the state vectors of the two terminals of one component by transfer matrix. Then, connect all components one by one, and multiply them together to obtain and solve the transfer matrix. Internal combustion engine shafting, according to its composition configuration characteristics, can be divided into three kinds of components: inertial disks - viscous damper components, elastic elements and even elastomer shaft section components.

The advantage of vibration calculation by transfer matrix method is that the order of transfer matrix will be not affected by the increased unit number, namely, the dimension of matrix will not increase with the increase of the freedom degree of the system, and the calculation method of each order vibration mode is identical. So with simple calculation, convenient programming and less memory for calculation and less time consumption, this method is widely used in the analysis and research of crankshaft vibration. However, when analyzing complex shaft with many freedom degrees by this method, due to the error accumulation of the transfer matrix, the calculation accuracy will decrease, thus the precision of higher frequencies computation is relatively low.

3.1.4 Energy method and amplification coefficient method

Both energy method and amplification coefficient method [2,23] belong to the resonance calculation method of forced torsional vibration, which are basic and the most important calculation methods of torsional vibration before electronic computer popularized. They are still widely used at present. The basic principle of energy method is that the input energy of the exciting moment within a system vibration period is completely consumed by system damping, namely, $W_M = W_C$. Amplification coefficient method was proposed by Tuplin in 1930's for resonance calculation, and then was further developed, becoming a guiding method that the Shipping Standard of British Lloyds Register recommends.

3.1.5 Modal analysis method

The basic thought of modal analysis method [24-25] is to decompose complex multi-freedom system into several sub systems. Firstly, when analyzing, compute the several lower modes of each sub system, then assemble each sub system into an integrated motion differential equation set according to displacement compatibilities or force balance relations between adjacent sub systems to derive comprehensive eigenvalue problem of shrinkage of Freedom

Degree., thus work out the inherent frequency A vibration mode and response of the system. Since modal analysis method reduces the freedom degree of the system, the time consumption and memory for calculation are significantly reduced compared with finite element method. If the sub systems are divided reasonably, its calculation precision is also satisfactory. In addition, modal analysis method can also combine with experimental research^[26] to obtain system vibration modal parameters by measuring the transfer function of shaft vibration, e.g., natural frequency, vibration mode, damping, modal inertia and modal rigidity, etc.

3.1.6 Finite element method

Finite element method^[1,2,7-10] is a numerical calculation method for solving mathematical physics equation based on variation principle. Its basic thought is to regard complex structure as finite set of discretized units. Each unit is connected into a unity through the common point of the neighboring units, namely, "joints". Take each unit as a continuous component and joint displacement as generalized coordinate. To establish torsional vibration mechanics model of the shafting of internal combustion engine, we need to define which units are selected as well as load positions and sizes, etc. Finite element method is currently accepted as with the highest calculation precision for torsional vibration calculation.

3.1.7 Substructure analysis method of the torsional vibration of systems with branch shafts^[27]

In the torsional vibration analysis of shaft systems with branches, the main commonly used methods are transfer matrix method, matrix iterative method and system matrix method, etc^[28-31]. But these methods are mainly used to analyze straight string structure or a particular branch. Their calculation efficiency is relatively low for the whole branching structure system. In general, substructure method has already formed systemic theory^[32-33], whose basic idea is to divide large and complex structure system into several substructures and calculate the dynamic characteristics information of each subsystem by finite element method, analytical method and experimental method, and then integrate them into the dynamic characteristics of the whole structure system. But substructure method is used less in torsional vibration analysis of shaft systems with branches. Representative method is dynamic substructure matrix method. This method requires working out the compatible relation among all substructures in substructure integrating, which leads to the complicated and tedious modal synthesis process in case the amount of divided substructures is large. Thus this method has certain limit in solving complex shaft systems with branches.

Chu Hua^[34] and Z P Mourelatos^[35] combined substructure method with transfer matrix method in torsional vibration calculation, which became a new migration substructure method, and the new method was compared with finite element method.

According to the structure of shaft systems with branches, Li Shen and Zhao Shusen^[27] put forward a method that divided substructures and integrate step by step based on gear meshing form to obtain the torsional vibration inherent characteristics of the whole system. This method was also used in analyzing the torsional vibration inherent characteristics of the structure of the main transmission system with branches of 650 rolling mill. The comparison with the results calculated by other methods shows the feasibility of substructure graded division and stepwise integration method. This principle has expanded the application scope of the substructure modal synthesis in solving the torsional vibration

of shaft systems with branches and effectively solved the problem of complex system, thus provided a good idea for solving the torsional vibration of shaft systems with branches.

3.1.8 New research methods for torsional vibration

In recent years, the number of scholars engaged in research of vibration has continuously increased and new algorithms kept on emerging continuously, such as elastic wave propagation method, eigenvector method and frequency analysis method, etc. According to the theory of torsional elastic wave, Bogacz^[36] gave out a method to solve torsional vibration dynamic response by torsion wave method. Shu Gequn and Hao Zhiyong^[11,37] also presented a new torsional vibration response calculation method based on the theory of torsional elastic wave, whose basic thought is: the torsional vibration of the shafting is caused by the torsional elastic wave propagation along the shaft; elastic wave propagates along the axis forward and back in traveling wave form; when one traveling wave meets with another after reflection or delay, both waves will stack into standing wave causing torsional vibration if their phases are appropriate. The method can be used to analyze continuous parameter distribution boundary, transient response and steady-state response of the crankshaft axis with transient boundary conditions and other vibration characteristics. Since it only requires solving linear equations in calculation, its computational complexity is small, thus it is an accurate and fast vibration analysis method. According to electromechanical analog principle, Gu Yujiong^[16] put forward a four-terminal network method for analyzing torsional vibration. State vector method, proposed by He Chengbing^[38], was widely used in the analysis of torsional vibration. People are also exploring the calculation method of continuous mass model for torsional vibration response of forced vibration. Wang Ke she and Wang Zheng guang^[39] used frequency analysis method in the calculation of torsional vibration to combine frequency change with the structural parameters of shafting, which was beneficial to visual analysis. It also worked out analysis mode, resonance frequency and resonant modes, etc.

3.2 Research direction of shafting solving methods

At present, the methods for solving torsional vibration are various and each has its own use. While in general, it shall be developed from the following aspects:

1. Improve the computation efficiency of current methods. For instance, calculation precision is high by finite element method, but its calculation is time consuming and resources occupying, so fewer and dimension-reduced units should be considered in model building when improving this method.
2. Combine the calculation method used in other industries with this direction.
 - 2.1 For example, Shen Tumiao^[16] mentioned to apply electrical four-terminal network in the calculation of torsional vibration. This is an example of unified calculation method. In addition, integrating all calculation methods to construct a new method is also one of the research directions.
 - 2.2 Based on the torsional vibration numerical simulation study of the internal combustion engine shaft with the precise time integration method, Lin Sen^[40] introduced and deduced the precise time integration based on Duhamel integral, described in detail the calculation characteristics of this method with example and comparison, simulated the torsional vibration of some type of internal combustion engine, compared the results with the calculation results

in literature, and analyzed their similarities and differences briefly, which, to a certain extent, solved the conflict between the accuracy and stability of calculation.

- 2.3 Along with the development of microcomputer technology, we can use professional software to analyze torsional vibration of internal combustion engine. Tong-Qun Han ^[41] introduced the functions and characteristics of engine simulation software EXCITE – designer developed by AVL company, analyzed torsional vibration and vibration reduction of the shaft system based on the software targeting at the problem of a car engine flywheel bolt fracture, and put forward correcting measures.

4. Experimental studies on engine crankshaft

4.1 Current torsional vibration measurement methods

Torsional vibration measurement is an important content in the study of crankshaft vibration. Compared with transverse vibration measurement, the extract and analysis of torsional vibration signals are both difficult. There are basically two kinds of torsional vibration measurements: contact measurement and non-contact measurement. The former installs sensor (such as strain gauge, accelerometer, etc) on the shaft, and the measured signal is transmitted to instrument by collector ring or radio signal. Non-contact measurement commonly uses “measuring gear method”, which uses shaft encoder, gear, or other repeated structure to measure angular velocity in homogeneity to measure torsional vibration. If designing Doppler test method properly, laser can also be used to measure torsional vibration. The followings are introduction to various methods and analysis of their error sources and applications.

4.1.1 Mechanical measurement

Geiger torsional vibration analyzer is a typical mechanical torsional vibration measuring instrument ^[2, 23] and was used in torsional vibration study in the earliest stage. This instrument is designed dexterously, whose signal acquisition and signal record are both realized by mechanical devices, simple and practical. It is widely used in the study of torsional vibration. DVL torsional vibration instrument also belongs to this type of torsional vibration instrument. However, the torsional vibration of this method is transmitted to measuring head shelf by belt, the belt elastic vibration will cause distortion. The response bandwidth of mechanical measuring system is very limited, and also because disc springs cannot be too soft, so very low frequency torsional vibration cannot be measured. In addition, the measured signal cannot be analyzed directly by means of modern analytical instrument, thus it has gradually been eliminated.

4.1.2 Contact measurement

Contact measurement ^[42] is to install sensor (such as inductance, strain gauge, etc.) on crankshaft directly. The measured signals are transmitted to analytical instrument by collector ring or in radio frequency manner. To monitor the dynamic response of shaft or shaft parts (e.g., blade, etc.), the arrangement of strain gauge should eliminate the interference of transverse vibration, and can realize the automatic compensation of influence by temperature. Torsional vibration meters belonging to this measurement method include

strain-gauge torsional vibration meter, piezoelectric torsional vibration meter and inductance-type torsional vibration meter, etc. Contact measurement, centered by sensing element, is widely used in the vibration test of internal combustion engine, thanks to its high sensitivity, wide frequency response range and convenience for measured signal record and analysis. But this kind of measuring device system itself has certain rotational inertia, which will inevitably impact on the system under test in measurement. In all kinds of contact measurement, measurement devices, such as sensors, are required being installed on the shaft, which sometimes has to destroy the original shaft structure. This is not allowed in many cases.

4.1.3 Non-contact measurement

The measurement device of non-contact torsional vibration measurement [43,44] is not installed directly on the crankshaft, but collects torsional vibration signals through photoelectric and magnetolectricity conversion by code disc, gear or other indexing structure on the crankshaft. These kinds of method are based on the principle of "gear testing". When the shaft is rotating, the teeth structure installed on the shaft can induce bell shaped pulse leveling signal sequences on the sensor, whose amplitude and phase might carry the information on axial torsional vibration, which is demodulated by phase detectors into torsional vibration signals. Torsional vibration meters belonging to this measurement methods include TV - 1 torsional vibration meter of British Econocruise Company, VED - 233A torsional vibration meter of American Shaker Company and DTV - 88 torsional vibration meter^[45] developed by Shanghai Institute of Electrical Equipment, etc. Non-contact measurement method does not need installing special devices on the shaft, but uses the existing shaft repeated structure, whose measurement preparations is less, and measurement process does not interfere with the normal operation of shaft. It's especially suitable for the long-term monitoring of torsional vibration. At present it has become a major means of torsional vibration measurement.

4.1.4 Laser measurement

Laser Doppler Torsional Vibration Measurement Technique [46-48] is put forward and developed from fluid velocity measurement. When laser beam irradiates on shaft surface, the linear velocity of shaft surface make scattered light produce Doppler frequency shift. The transient angular velocity of shaft represents the transient value of frequency shift volume of the instantaneous axis. Torsional vibration is obtained by removing dc component. 2523 torsional vibration meter launched out by the Denmark B&K Company was a typical representative of Doppler laser torsional vibration meter. In 1994, Ge Weijing^[49] and others from Tianjin University applied laser Doppler velocimetry on the torsional vibration measurement of internal combustion engine shaft. Only a smooth section on the surface of the shaft is required, and measuring point is easy to be set up. This method can realize absolute measurement and measurement datum is not required to be specially established. However, since the transverse vibration of the shaft and the form and position errors of the shaft section directly affect measurement precision, it is rather difficult to improve its accuracy.

4.1.5 The latest torsional vibration measurement method

Wang Ting and Cheng Peng^[50] introduced a kind of digital measurement system of crankshaft using PC computer. The measurement system consists of angle encoder, self-

made count plate, PCL724 digital input/output card and PC computer, etc. installed on the tested crankshaft. Angle encoder is crankshaft angle sensor with high precision, and is connected with crankshaft by flange. The grating disc fixed in the angle encoder has two reticules, e.g., outer and inner rings. The outer ring is a uniform reticule, which can produce CDM signals, and the inner ring is a TRIG reticule for judging tdc signal. The light emitting components in the angle encoder are two infrared light emitting diodes, and there are two infrared light receptors respectively corresponded with CDM reticule and TRIG reticule. When angle encoder operates together with crankshaft, a TRIG signal will be outputted in each rotation, and a series of CDM square-wave pulse signal will be outputted. Thus, the crankshaft torsional vibration can be directly reflected on the time width of the CDM square-wave pulses outputted by angle encoder. Count each CDM pulse width with frequency division by high count circuit board. The counted data is inputted into PC by parallel data I/O card PCL - 724. Then crankshaft torsional angle can be obtained after program processing. The measurement system measures torsional angle directly, thus it's with convenient measurement, high precision and simple process.

4.2 Research direction of torsional vibration measurement of internal combustion engine

The focus and future development of torsional vibration measurement is to improve its accuracy and real-time performance to realize the torsional vibration monitoring of internal combustion engine in operation, especially the monitoring of severe torsional vibration caused by emergencies, such as the severe torsional vibration by transient large torque incentive resulted from cylinder flameout. At the same time, eliminating the interference of lateral vibration and establishing reliable measurement datum are still the problem requiring to be solved. Finally, the problem of system calibration should also be solved.

5. The latest research direction of torsional vibration of internal combustion engine

The traditional research methods of torsional vibration can not meet the needs on the precise study. In recent years, many scholars have continuously broadened research field and scope to further explore the various problems of shaft torsional vibration, making the research on torsional vibration closing to ideal level unceasingly. Some main research directions of torsional vibration in recent years are introduced as follows.

5.1 Nonlinear research

With the further research on torsional vibration of the shaft, many nonlinear vibration problems are met [51-55]. At the same time, crank shaft is a complex nonlinear system, thus it often needs to consider all sorts of complex nonlinear factors to construct a model that can reflect actual system. However, current relevant studies are mostly on single degree-of-freedom nonlinear vibration problems that considers single factor, which obviously cannot meet the need on the accurate calculation of crankshaft vibration. Therefore, it is necessary to further consider the crankshaft nonlinear vibration problems with multiple nonlinear factors, multi-degree-of-freedom and even continuous mass distribution. In the current calculation models, equivalent moment of inertia (constant) is usually adopted to consider the inertia of piston and connecting rod. But in fact, the inertia of engine crank module is:

$$I = I_0 [1 - \varepsilon \cos(2\varphi)]$$

Where ε is variable inertia coefficient, a value below 1. We can see from the formula, the moment of inertia of crank component is a variable related with rotation angle. Sheng Gang [56] researched on the solution methods of some simplified models of single cylinder engine and established the equation of motion of crankshaft vibration of multi-cylinder engine under the condition of considering variable inertia. At the same time, in literature [1], the problems of variables caused by machining error and assembling error were also considered. In literature [57], forward and inverse Fourier transformation was applied to numerically solve nonlinear torsional vibration system. While Lin Ruilin [58] took the diesel engine shaft with a third-order rigidity component as research object, deduced the calculation formula and numerical calculation formula iterative procedure for solving periodic response of nonlinear torsional vibration by incremental harmonic balance method (IHB). This method is used to solve linear and nonlinear torsional vibration response of diesel engine shaft. Compared with the existing methods, it is more effective to solve strong nonlinear vibration response. What's more, it has virtues of less operation time and accurate calculated result.

The discussion about nonlinear components is mainly concentrated on the non-linear shock absorber, coupling and other components. Literature[59] of as early as 1987 analyzed the nonlinear problems of diesel engine shaft with piecewise linear components (cylindrical spring-loaded buffers), and calculated vibration response of shaft by step-by-step integration method. Gong Xiansheng[55] introduced theoretical and experimental research on the calculation method of steady state vibration response of marine propulsion shafting with hysteretic nonlinear coupling subjected to eccentric mass exciting force action. Farshidianfar [60] solved nonlinear problems of driving shaft by substructure modeling, and compared the results with the results of whole structure modeling.

The research on nonlinear torsional vibration has made many important achievements [50]. But so far, the majority of nonlinear torsional vibration problems are still analyzed by some approximate methods or by ignoring nonlinear factors, in most cases, the results obtained have greater errors compared with actual results. Therefore, there are still many problems waiting to be solved in further exploring the nonlinear problem, mainly including:

1. The modeling, system parameters identification method and test of complex nonlinear torsion vibration problems;
2. Accurate solving methods for multi-degree-of-freedom strong nonlinear torsional vibration problems;
3. Self-excited vibration of complex nonlinear torsional vibration system;
4. Decoupling, numerical calculation and optimization methods of complex nonlinear structure.

5.2 Coupling vibration analysis

Torsional vibration of shaft has huge harm on the system, so people paid attention to and researched on it at very early period. However, many phenomenon produced by vibration in practice need to take longitudinal/bending/torsional vibration together into account. The bending vibration caused by unbalanced mass has certain weight on the torsional direction and can couple to the torsional vibration; on the other hand, torsion also has certain weight on horizontal and vertical directions, thus couples to the bending vibration. In recent years,

significant progress has been made in the aspects of theoretical calculation method and testing technology of longitudinal/bending/torsional coupling vibration.

Li Bozhong [62] discussed about the axial vibration problems caused by torsional vibration and established a relatively simple analysis model for this kind of model. In the following two literatures^[63,64] of same series, the longitudinal twist coupling vibration was tested and further analyzed and the coupled vibration model was established, and the model calculation was compared and analyzed with actual measurement. In paper^[65], the author put forward a kind of spring - mass model with non-linear rigidity being used in calculating torsional - vertical coupled vibration of engine shaft. It explained the doubled-frequency problem of the torsional - longitudinal coupling, and also revealed the presence of quadruple frequency and octuple frequency in the longitudinal - torsional coupled response. It is more reasonable than just simply giving an assumption doubled-frequency excitation torque in the right of the motion equation. Zhang Yong and Jiang Zikang^[66,67,68] adopted distributed mass model in analyzing bending - torsional coupling vibration of shaft, which divided the actual unit shaft system structure into several sections with equal diameter according to orders in simplifying, treated each segment as continuous mass, and listed the vibration differential equation of each segment, then united them to solve. Finally, some results of the analysis for bending - torsional coupling vibration of shaft by numerical method were given. In literature^[69], system matrix model was established for longitudinal twisting coupling vibration of shaft, whose general rule of coupling vibration was studied based on the calculation and analysis of the practical examples of longitudinal twisting coupling vibration of shaft. In this paper, the test equipment used for measuring coupling vibration is only eddy current sensor for non-contact measuring the condition of axis vertical vibration. In contrast, multi-dimensional measurement is relatively rare.

Okamura[70] and Shen Hongbin[71] used the longitudinal / bending / torsional vibration test device in all research processes of shaft vibration. This kind of measuring device can acquire three-dimensional vibration signals simultaneously. As shown in figure 5, an electromagnetic sensor (measuring torsional vibration signal) and three acceleration sensors (of which, one measuring longitudinal vibration signals and the other two measuring bending vibration signals) are mounted on its shell. It shows that testing technology has also been developed from single parameter measurement to multi-parameter measurement method.

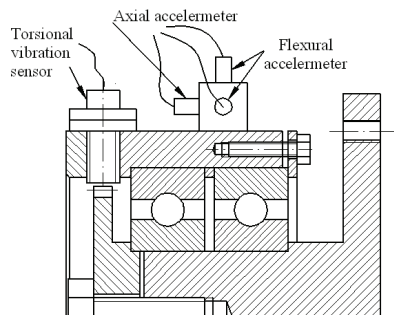

Fig. 5. Three-dimensional torsional vibration measurement schematic diagram

For the research of torsional vibration with coupling vibration and transversal vibration, the current research level is far insufficient. Especially in the study of theoretical models,

traditional method can not unify the physical model and mathematical model of coupling vibration simultaneously. In view of this, the future research on coupling vibration can roughly focus on the following aspects:

1. Mechanism research on coupling vibration and relay relation of mutual excitation;
2. Model unification and solve using universal algorithm;
3. Precise treatment of measuring equipment, long distance measurement and the implementation of long-term test, etc.

5.3 The analysis of torsional vibration response based on multi-body dynamics of soft body crank shaft

The forces on engine are very complex. Traditional analysis method is to calculate rotation inertia and reciprocating inertia produced by each force based on the motion analysis of each component, then combine them with the maximum combustion pressure of gas to solve the force on the main body and excitation force of shaft vibration. This is a very complicated process^[73]. By using mechanical system simulation software ADAMS, by establishing crankshaft multi-body dynamics model including pistons, connecting rod, crankshaft and flywheel, we can not only calculate the motion law and the force among each component, but can also further analyze balance and vibration. Due to the interaction between inertial load and transverse bending deformation of shaft and the coupling behavior with lubrication problem, the bearing load problem based on rigid body dynamics becomes complicated, and there exist errors in calculation precision. If transforming engine crankshaft into flexible body, the tiny deformation can guarantee the completely accurate dynamic equation to deformation generalized coordinates first-order items. In order to sufficiently study the effect of crankshaft flexible body on the calculation results of dynamics, based on the finite element analysis of crankshaft system and by establishing rigid-flexible coupling multi-body dynamics system model with multiple degrees, Liang Xingyu and Shu Gequn^[72] analyzed the torsional vibration response of crankshaft system that constitutes main flexible body, and obtained the time history response of system dynamics, and then made assessment on the power quality and safety of the system. Then it measured the torsional vibration of the crankshaft free end of an inline four cylinder diesel engine with a newly developed test device. Through calculation and comparison between sub-harmonic analysis of test results, both reflected higher equality, and explained the correctness of rigid-flexible coupling multi-body dynamics system model.

5.4 The method of compensating divisional error in shafts torsional vibration measurement and program implementation [74]

Now non-contact measurement method are generally used for torsional vibration measurement, namely, by using repeated structure in the shaft, pulses are produced in non-contact sensor, and the interval dimension reflects the transient angular velocity dimension of the shaft. The shaft torsional vibration information can be obtained by processing interval data of the pulses. When measuring torsional vibration by this method, the indexing error of the shaft repeated structure directly influences the precision of measurement results. If indexing error is very great, the measurement results will have serious distortion. In the measurement of torsional vibration by non-contact measurement method in practice, selected sensors mainly include photoelectric encoder, hall sensor and photoelectric sensor. The three kinds of sensors in practical measurement have their advantages and

disadvantages. Photoelectric encoder has large indexing number and small indexing error, so its measurement is more accurate. But its installation is inconvenient and it requires using shaft coupling to connect with measured shaft. If encoder shaft is eccentric with measured shaft after installation, transmission eccentric error will be introduced^[73]. Hall sensor requires gearing disc with equal division to measure. Since the teeth number of equal division disc is usually less than the indexing number of encoder, and gear disc has certain indexing error in processing, its accuracy is lower than that of encoder. But its installation is convenient. It can be directly installed on the measured shaft, or can directly measure by gear disc on the shaft without additional modification on the shaft. The use of photoelectric sensor is of the most convenience. It needs only uniformly pasting a certain number of reflective strips on the component with circular surface of the shaft. If the shaft is very thick, those reflective strips can be directly pasted on the shaft. However, currently, the reflective strips can only be manually pasted. Great degree error will definitely occur leading to the distortion of measurement results. So in the actual torsional vibration test, if the indexing error of selected repeated structure can not be ignored, such as selected manually pasted turntable of reflective strips, test results should be dealt with to compensate for the effects of indexing error, then correct torsional vibration information can be calculated. Guo Wei-dong^[74] described the compensation principle of indexing error in detail and listed the compensation program of indexing error compiled based on LabVIEW. So we could find out from test results that the data curves after the compensation of indexing error became smooth, and the effect that indexing error on measured results is obviously reduced and test result is more accurate.

6. Control technologies in torsional vibration of internal combustion engine

For the internal combustion engine with reciprocating motion, due to the property of periodical work, the torque on the shaft is a periodic compound harmonic torque, and then forms excitation source. When the frequency of the excitation source is equal to the inherent vibration frequency, resonance phenomenon will occur, and torsional vibration will be subjected to huge dynamic amplification effect, then the torsional stress on the shaft greatly increases, leading to various accidents on the shaft, and even fracture. These are the causes and consequences of torsional vibration.

To avoid the destructive accident of torsional vibration of internal combustion engine, it's not only required to conduct detailed calculation of torsional vibration in design phase, torsional vibration measurement is also required timely after manufacturing completion. This can not only check and modify the theoretical calculation results, but also detect and so as to solve the torsional vibration problems promptly.

Based on the above analysis, main vibration control technology includes two parts: study on the avoidance of vibration and on shock absorber.

6.1 Study on the avoidance of vibration

If great torsional vibration does exist on internal combustion engine according to the calculation of and actual test on torsion vibration, proper measures shall be taken to avoid or remove it.

There are a lot of preventive measures for avoiding torsional vibration^[61], classified roughly into the following two methods.

6.1.1 Frequency adjustment method [2, 76]

According to torsional vibration characteristics, when the frequency of excitation torsional vibration is equal to some inherent frequency n_w of torsional vibration system, extremely severe dynamic amplification phenomenon will occur, namely resonance phenomenon, thus the possibility of $w = n_w$ shall be avoided, i.e., avoidance of the most severe conditions of dynamic amplification means the possibility of avoidance of all consequences caused by excessive torsional vibration. The basic concept of this method is that let w actively avoid n_w . The main measures of this kind of method include: inertia adjustment method and flexibility adjustment method, etc. By adjustment, let the natural vibration frequency of the system itself avoid excitation frequency. Reduce vibration stress to be within the instantaneous allowable stress range, thus avoid the damage on engine by bigger torsional vibration. This method is one of the most widely applied measures in torsional vibration prevention measures, not only because of it being a simple and feasible measure, but also because of it being effective and reliable when meeting the requirement of frequency modulation. But its disadvantage is small scale of frequency modulation, which restricts its practical application.

6.1.2 Vibration energy deducing method [23]

Incentive torque is the power source causing torsional vibration. Since the input system energy of incentive torque is the source of maintaining torsional vibration, if the vibration energy of input system can be reduced, the magnitude order of torsional vibration can also be reduced immediately. One way is to change the firing sequence of internal combustion engine. When the dangerous torsional vibration is deputy critical rotation speed within machine speed range, this method might be used to reduce the dangerous torsional vibration and reduce the risk degree. The second method is to change crank arrangement. Deliberately choosing unequal interval firing in multi-cylinder engine and appropriately choosing crank angle to change crank arrangement can let some simple harmonic torsional vibration in any main-subsidiary critical speed counteract mutually to avoid dangerous torsional vibration. The third method is to choose the best relative position between crank and power output device, make the disturbance torque between them counteract mutually, which can reduce the torsional vibration of the crankshaft.

6.1.3 Impedance coordination method

Considering the complexity of solving above problems by the conventional dynamics method, energy wave theory can be used to solve this problem. According to energy wave theory and by coordinating the impedance of various component loops, resonance can be avoided to realize the target of reducing vibration intensity. Impedance coordination method can modify the inferior design in design phase, or design directly correct transmission shaft system, to ensure the shaft working with sound dynamic characteristics without resonance and reducing dynamic load.

6.2 Study on shock absorber

As is known to all, engine installed on shock absorber can greatly reduce the vibration transmitted to the foundation. Likewise, torsional vibration can also be eliminated before it reaches the foundation. If vibration reducing device is installed on the front head of the crankshaft of the engine, then shock absorber will absorb the torsional vibration of rotating shaft generated by engine. It shows the important role of shock absorber in internal combustion engine system. The technical requirements on shock absorber are very high,

mainly including: elastic material strength should be reliable in use and storage, the fixation with metal should be firm, rigid fluctuation range in installation stage should be small, and technical characteristics do not change with time.

Now, main shock absorbers include the following kinds: dynamic shock absorber, damping shock absorber and dynamic-damping shock absorber.

6.2.1 Dynamic shock absorber [2, 23, 77]

This kind of shock absorber is connected with crankshaft by spring or short shaft. By the dynamic effect of shock absorber at resonance, an inertia moment with the size and frequency same with excitation torque, but direction opposite to excitation torque is produced at the vibration reduction location to achieve the purpose of vibration reduction. This kind of shock absorber doesn't consume the energy of the shaft. They can be divided into two types: one type is constant fm dynamic shock absorber, namely undamped elastic shock absorber, shown in the schematic of figure 6, and the other type is variable fm dynamic shock absorber, such as undamped tilting shock absorber, drawing as shown in figure 7.

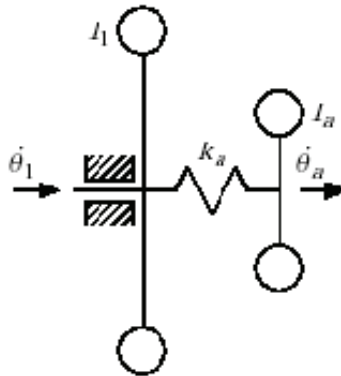

Fig. 6. Undamped elastic shock absorber schematic diagram

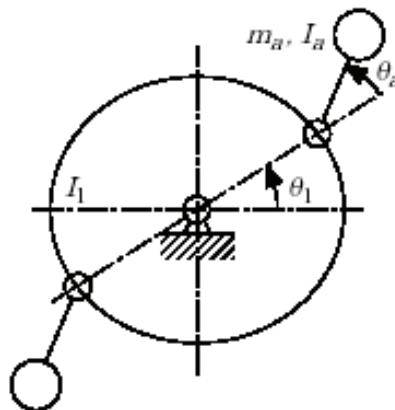

Fig. 7. Undamped tilting shock absorber schematic diagram

6.2.2 Damping shock absorber

Damping shock absorber achieves the purpose of vibration reduction by damping consuming excitation energy (shown in schematic diagram 8). The main type is silicone oil damper^[78,79], whose shell is fixed to the crankshaft, high viscosity silicone oil is filled between ring and shell. When the shaft is under torsional vibration, the shell and the crankshaft vibrate together, and the ring moves relatively with the shell due to inertia effect. Silicone oil absorbs vibration energy by friction damper, thus reduce vibration for the torsional vibration system. This kind of shock absorber is widely used with simple structure, good effect of vibration isolation and reliable and durable performance.

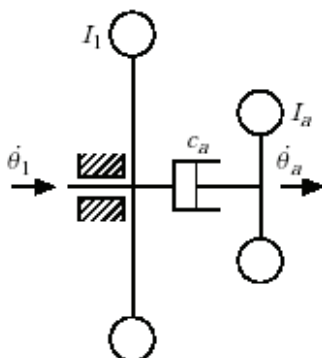

Fig. 8. Damping shock absorber schematic diagram

6.2.3 dynamic-damping shock absorber

Dynamic damping shock absorber features both of the above effects, such as rubber flexible shock absorber^[80], rubber silicone oil shock absorber, silicone oil spring shock absorber^[81], etc., shown in schematic diagram 9. Theoretically, the effect of dynamic damping shock absorber is the best, since it can not only produce dynamic effect by elastic, but also consume excitation energy by damping. But the elastic elements, such as springs and rubber, etc., that connect the shock absorber and crankshaft often work under great amplitude and high stress, thus the process is relatively complex and the cost is higher.

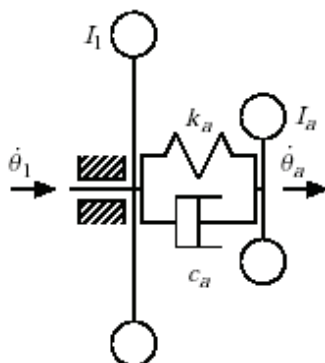

Fig. 9. Dynamic-damping shock absorber schematic diagram

6.2.4 Study on new shock absorber

Along with the deepening of the research on shock absorber, many new shock absorbers have appeared. Several typical kinds are listed as below:

Yan Jiabin ^[82] proposed an elastic metal shock absorber, which fixed two disks connected with elastic materials at the ends of the crankshaft. disks are tightened in the way that one disk rotates in the opposite direction of the other disk (see figure 10). If loosen both disks simultaneously, they will complete torsional vibration with low amplitude, till stop. At this moment, one section of the shaft rotates in one direction, and another section of the shaft rotates in the other direction. In this case, one end face of the crankshaft will produce displacement. Due to the effect of vibration absorption, the vibration will proceed with reduced amplitude but constant speed, which depends on the internal friction or delayed quantity of elastic material. There are three kinds of elastic shock structure of shock absorber: welding metal elastic elements, combination elastic metal components and welding-combination elastic metal elements. Welding-combination elastic metal elements consist of driving and inertia members that connect each other with elastic material. This kind of shock absorber is suitable for application with simple structure and convenient maintenance.

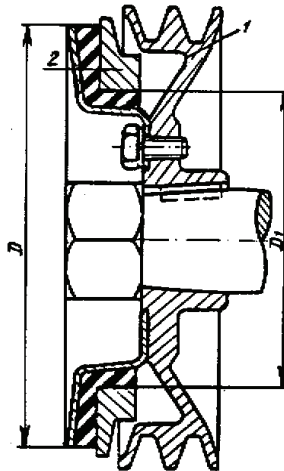

Fig. 10. Monolayer thin-type elastic metal shock absorber

Huo Quanzhong ^[83] and Hao Zhiyong^[84] introduced the research on driving control shock absorber. Figure 2 is the diagram of the shock absorber. The shock absorber itself is similar to a dc motor, whose stator and the shell of the shock absorber compose as a whole entity, and rotor is connected with the shell by radial leaf spring, forming a dynamic shock absorber. The shell of the shock absorber is fixed on the main vibration body. According to the conditions of main vibration body, the regulation apparatus produces control signals with fixed size, phase and frequency, which, by power amplifying, make armature generate control torque (namely, electromagnetic torque). Active torsional vibration shock absorber is feasible both in theory and practice. What's more, its damping effect is better than that of dynamic shock absorber.

Liu Shengtian ^[85] proposed a double-mass flywheel torsional vibration shock absorber, which was a new type of torsional vibration shock absorber occurred in the middle of

1980's. The double-mass flywheel torsional vibration shock absorber at early period was to remove torsional vibration absorber from the clutch driven plate, place it among engine flywheels, thus double-mass flywheel torsional vibration shock absorber was formed. The basic structure of double-mass flywheel torsional vibration shock absorber has three major parts, i.e. the first mass, the second mass and the shock absorber between the two masses. Relative rotation can exist between the first and the second masses, which are connected with each other by shock absorber.

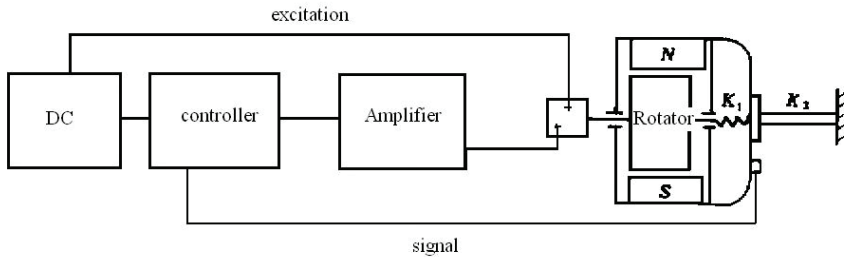

Fig. 11. Active control shock absorber functional diagram

Double mass flywheel torsional vibration shock absorber can very effectively control torsional vibration and noise of automobile power-transmission system. Compared with the traditional clutch disc torsional vibration shock absorber, its effect of damping and isolation of vibration is not only better within the common engine speed range, it can also realize effective control over idle noise. After developing the double-mass flywheel torsional vibration shock absorber, the author also introduced hydraulic pressure into shock absorber and developed hydraulic double-mass flywheel shock absorber [86], which is the latest structure style in the family of double-mass flywheel torsional vibration shock absorber. It lets the technology of car powertrain and noise control of torsional vibration step further into the direction of excellent performance and simple structure.

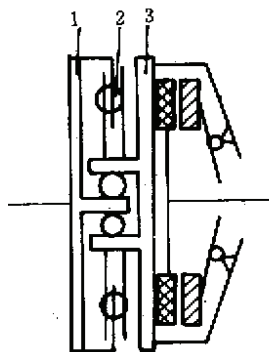

Fig. 12. Double-mass flywheel torsional vibration shock absorber

M Hosek, H Elmal [87] introduced the design process of a kind of FM tilting shock absorber, which was developed based on centrifugal tilting shock absorber, and was named as

centrifugal delay type resonator by the author. Based on the study of centrifugal tilting shock absorber, the author installed a sliding globule between the end of pendulum and the rotary table, thus, when the rotation of the shaft fluctuates, the pendulum will delay due to the effect of damper, while the sliding globule will coordinate actively with the changes. By this shock absorber, minor disturbance can be quickly completely eliminated; and broadband disturbance, especially the disturbance that obviously increases speed, also can be completely eliminated.

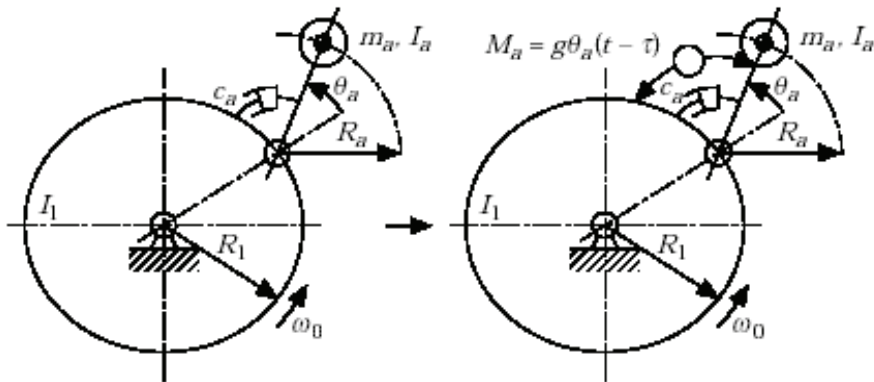

Fig. 13. Centrifugal delay resonator

Shu Gequn [88,89] presented a research approach of coupling shock absorber. Since torsion vibration is the most dangerous vibration mode in shaft vibration, torsional vibration shock absorber is the main damping device, and for coupling damping, bending shock absorber or lateral shock absorber will be installed on the basis of torsional vibration shock absorber. Through the experimental research, the author concluded that, compared with single torsion vibration damper, after installing bending vibration shock absorber, due to the effective damping act on shaft bending vibration, twist/bending shock absorber can control engine vibration and noise effectively. Normally, the parameters setting of bending vibration shock absorber depends on the bending vibration model of crankshaft, but due to its effect on torsion vibration reduction, the design of coupling shock absorber should consider its damping effect on torsional vibration and bending vibration of the shaft. Shu Gequn [90] investigated the effect of bending shock absorber on the performance of twist/bending shock absorber by theoretical analysis.

Through the above analysis, we can see that torsional vibration absorber is being developed towards the aspects of broadband, high efficiency, being timely, multi-function, etc. So research on torsional vibration shock absorber still has considerable prospect, worthy more efforts from scholars. The following aspects can be studied and explored.

1. Study on active control of torsional vibration of internal combustion engine;
2. Study on shock absorber with coupling between torsional vibration with longitudinal vibration and transverse vibration, etc;
3. Study on integrating torsion vibration absorber with clutch or other components of internal combustion engine;
4. Finite element optimization design of torsional vibration shock absorber [91].

7. Utilization of torsional vibration of internal combustion engine crankshaft

Restricted by various factors, we can only decrease the degree of torsional vibration, while the occurrence of torsion vibration is inevitable. Torsional vibration is directly related to the various incentive factors of internal combustion engine, such as the combustion sequence of various cylinders, the change of crankshaft inertia and the sudden change of loads, etc. So how to use torsional vibration signals to monitor the changes of these quantities is the main purpose of utilizing torsional vibration. The utilization of torsional vibration is mainly embodied in identifying faults by torsional vibration signals^[92, 93].

7.1 The progress of torsional vibration utilization

The diagnosis of diesel engine faults by the change of torsional vibration parameters of the shaft is a new fault diagnosis technology. Torsional vibration signals of diesel engine shaft often have strong repeatability and regularity, and fault diagnosis by torsional vibration signals is used to diagnose cylinder flameout. Diagnosing cylinder flameout fault by torsional vibration signal of diesel engine has been developed in recent years. The work process fault of diesel engine cylinder directly affect the changes of torsional vibration characteristics, and such changes of torsional vibration parameters also reflect directly the work state of cylinders. Torsional vibration signals of diesel engine shaft can be used as the basis for fault diagnosis. Ying Qiguang explored this issue at the beginning of 1990's of the 20th century, who thought that diagnosis of the technical condition and fault of diesel engine by the response characteristics of the frequency, amplitude (and phase) and damping of shaft torsional vibration is a new and promising fault diagnosis technology. The author judged cylinder flameout fault by the comparison of amplitude size between normal torsional vibration and in the circumstance of cylinder flameout. This method is convenient and intuitive. However, it requires normally torsional vibration amplitude figure for comparison under the same conditions, so its application is limited^[94]. In the application of fault diagnosis by torsional vibration, Lin Dayuan and Shu Gequn studied on the sensitivity of various torsional vibration modals and frequency response characteristics on crack by torsional vibration modal experiment, who recommended modal damping, damping attenuation factor, frequency response function modal and self-spectral modal as the optimum evaluation factors for the crack fault, and further discussed the change law between crack and the above evaluation factors, thus provided an effective method of intermittent diagnosis for the engine stops^[95,96].

7.2 The development direction of torsional vibration utilization

Fault diagnosis by torsional vibration signal of internal combustion engine crankshaft is a new type of fault diagnosis theory. Developing this theory towards new application field is an inevitable trend in internal combustion engine industry. Thus, the development direction of torsional vibration is mainly oriented to broader fault diagnosis fields and continuously make this achievement become more mature and its application become more skilled.

7.3 Sub-conclusions

1. Damping technology becomes more mature.
2. Multi-function shock absorbers are innovated constantly.
3. Application fields of torsional vibration become more and more wide.
4. Modern design theory is used unceasingly in control field.

8. Conclusions

Research on torsional vibration of internal combustion engine will become more and more deepen with the development of science and technology. Corresponding new research methods will appear in modal building, solving, test and control of the shaft model, making research contents more wide, method more scientific, object more specific and application more direct.

9. Acknowledgements

Authors wish to express their sincere appreciation to the financial support of the NSFC(50906060) and State Key Laboratory of Engines.

10. References

- Tan Daming. Vibration control of internal combustion engine [M]. Southwest Jiaotong university press, 1993.
- Yu Qi. Torsional vibration of internal combustion engine [M]. Beijing: National Defense Industry Press, 1985.
- W J Hshen. on the Vibration Analysis of Multi-Branch Torsional System[J]. Journal of Sound and Vibration,1999,224(2):209-220.
- Nestorides E J. A Handbook on Torsional Vibration[M]. London: Cambridge University Press, 1958.
- Wilson W K. Practical Solution of Torsional Vibration Problem[M]. London: Campman and Hall, 1963.
- A Boysal and H Rahnejat. Torsional Vibration Analysis of a Multi-body Single Cylinder Internal Combustion Engine Model[J]. Appl. Math. Modeling,1997,21(8):481-493.
- Wang Changmin, Zhu Dejun. Calculation of Torsional Stiffness of Engine Crankthrow by Finite Element Method [J]. Transactions of CSICE, 1991,9 (2) : 177-183.
- Qu xiaoming, Gu yanhua, Wang xiaohu. Modeling and calculation of torsional vibration of internal combustion engine [J]. Internal combustion Engines, 2000,4:6-9.
- Li Huizhen, Zhang Deping, Crankshaft Torsional Vibration Calculation by Finite Element Method [J]. Transactions of Csice, 1991,9 (2) : 157-162.
- K Koser, F Pasin. Continuous Modeling of the Torsional Vibrations of the Drive Shaft of Mechanisms[J]. Journal of Sound and Vibration,1995,188(1):17-24.
- Hao Zhiyong, Shu Gequn. An Investigation on the Torsional Elastic Wave Theory for the Calculation of Crankshaft [J]. Torsional Vibration Response in I. C. Engines. Transactions of Csice, 2000,18 (1) : 29-32.
- J Q Pan, J Pan, R S Ming, T Lin. Three-Dimensional Response and Intensity of Torsional Vibration in a Stepped Shaft [J]. Journal of Sound and Vibration,2000,236(1):115-128.
- Chen Yong, Lu Songyuan, Gu Fang, Wang Yumin. The Calculation and Analysis of Torsional Vibration Characteristic of Turbine Generator Rotor System. [J]. Turbine Technology, 1999,41(5):276-279.
- Liang Xingyu, Shu Gequn, Li Donghai, Shen Yinggang. Torsional Vibration Analysis Based on Multi-body Dynamics of Flexible Crankshaft System [J]. Chinese Combustion Engine Engineering, in 2008, the fourth period.

- Li Renxian. Calculation of Loads on Crankshafts of Internal Combustion Engines Based on Continuous Beam Model [J]. Journal of Southwest Jiaotong University, 1998,33(2): 164-169.
- Gu Yujiong, Yang Kun, He Chengbing, ect. Simulations on Torsional Vibration Characteristics of Turbogenerators Based on Four-Terminal Network Method [J]. China Mechanical Engineering, 1999,10(5):540-542.
- He Shanghong, Duan Jian. Network method for dynamic modeling of complex shafting torsional vibration system [J]. The Chinese Journal of Nonferrous Metals, 2002,12(2): 388-392.
- Xiang Jianhua, Liao Ridong, Zhang Weizheng. Study and Application of Graphic Modeling Techniques of Shaft Torsional Vibration Based on System Matrix Method [J]. Acta Armamentarii, 2005-03-001
- Yu Yinghui, Zhang Baohui. Development And Prospect of Research on Turbine-Generator Shaft Torsional Oscillation [J]. Automation Of Electric Power Systems, 1999,23(10):56-60.
- He Chengbing, Gu Yujiong, Yang Kun. Summarization on torsional vibration model and algorithm of turbogenerator unit [J]. Journal of North China Electric Power University, 2003,30(2):56-60.
- Liu Hui, Xiang Changle, Zheng Muqiao. Torsional Vibration on the Complex Shaft System of a Vehicular Powertrain [J]. Journal of Beijing Institute of Technology, 2002,22(6):699-703.
- Honda Ym, Wakabayashi K, Matsuki K. Torsional Vibration Characteristics of a Diesel Engine Crankshaft with a Torsional Rubber Damper by Using Transition Matrix Method [J]. JSAE Review, 1996,17(1):89.
- Li BoZhong, Chen ZhiYan, Ying QiGuang. The torsional vibration of internal combustion engine crankshaft system[M]. Beijing: National Defense Industry Press, 1984.
- G D Jenning, R G Harley. Modal Parameters and Turbo-Generator Torsional Behavior[C]. IEEE 3rd AFRICON Conference,1992:517-520.
- Wang Guozhi, Modal Analysis Method in Research on Torsional Vibration of Diesel Engine Shafting System [J]. Transactions of Csice, 1986,4(3):249-259.
- Shen Tumiao. Dynamic Measurement and Calculation of Twisting Stress of Crankshaft and Flywheel System in Diesel Type TC 387 [J]. Transactions of Csice, 1993, 11(6):243-248.
- Li Shen, Zhao Shusen. Study on Substructure Method for Torsional Vibration of a Branch Shafting System [J]. Journal of Vibration and Shock, 2007-10-033.
- Qu Zhihao, Chai Shaokuan, Ye Qianyuan. Analysis of Dynamic Characteristics and Chatter Of A 1420 Cold Tandem Rolling Mill [J]. Journal of Vibration and Shock, 2006, 25(4): 25-29.
- Xiang Jianhua, Liao Ridong, Zhang Weizheng. Study and Application of Graphic Modeling Techniques of Shaft Torsional Vibration Based on System Matrix Method [J]. Acta Armamentarii, 2005, 26(3): 294-298.
- Wei Haijun. Modification of Some Formulas for Calculating Shaft Torsional Vibration [J]. Journal of Vibration and Shock, 2006, 25 (2): 166-168.
- Ji Chen, Zeng Fanming. Study on the general model and system matrix method for torsion vibration calculation of complex shafting [J]. Ship & Ocean Engineering, 2006(4): 55-57.

- Li Lin, Sheng Jun. Mixed Interface Direct Component Modal Synthesis Method [J]. Chinese Journal of Applied Mechanics, 2005 22 (2): 315-319.
- Xiang Shuhong, Qiu Jibao, Wang Dajun. The Resent Progresses on Modal Analysis and Dynamic Sub-Structure Methods [J]. Advances In Mechanics, 2004, 34(3): 289-303.
- Chu Hua, She Yinghe. A Substructure Transfer Matrix Method in Torsional Vibration Analysis of Rotor System [J]. Journal of Southeast University, 1989,19(3):87-95.
- Z P Mourelatos. An Efficient Crankshaft Dynamic Analysis Using Sub structuring with RITZ VECTORS[J]. Journal of Sound and Vibration, 2000,238(3):495-527.
- Bogacz, Szo1c T, Irretier H. An Application of Torsional Wave Analysis to Turbo generator Rotor Shaft Response[J]. Trans. of ASME, Journal of Vibration and Acoustics, 1992, 114(2):149-153.
- Shu Gequn, Hao Zhiyong. An Investigation on the Torsional Elastic Wave Theory for the Calculation of Multi-Stepped Shaft Torsional Vibration Response [J]. China Mechanical Engineering, 1999,10(11):1277-1279.
- He Chengbing, Gu Yujiong, Yang Kun. The Analysis of the Shaft Torsional Vibrations Response of Turbine-generator Units Based on State-Space Method [C]. Asia-Pacific Vibration Conference, China, 2001.
- Wang Ke she, Wang Zheng guang. Frequency analysis method of shafting crangle vibration [J]. Journal of Beijing Institute of Machinery, 2001,16(4):11-18.
- Lin Sen, Zhang Hongtian, Geng Ruiguang, et al. Study on numerical emulator of shafts' torsion vibration of internal-combustion engine based upon time step integration method [J]. Journal of Heilongjiang Institute of Technology, 2008, 22(1):1-7.
- Tong-Qun Han, Sheng-Hua Yao, Sheng-Jun Wu. Analysis of Torsional Vibration of Crankshaft System of a Vehicle Diesel Engine Based on EXCITE-designer Software. Journal of Hubei Automotive Industries Institute, 2005, 19(4): 5-8.
- Yang Yanfu, Measurement and Application of Torsional Vibration in Engine[J]. Ccec Science & Technology,1997,4:1-6.
- Huang Diangui. Experiment on the Characteristics of Torsional Vibration of Rotor-to-stator Rub in Turbo Machinery[J]. Tribology International,2000,33:75-79.
- Xia Qingjie. 16V240ZJC Diesel Engine Torsional Vibration Measurement and Analysis[J]. Si Ji Science & Technology,1998,4:16-19.
- Guo Li, Li Bo. , Assessment of Torsional Vibration Measurement Method[J], Grinder and Grinding. 2000,3:53-56.
- N A Halliwell. The Laser Torsional Vibrometer: A Step Forward in Rotating Machinery Diagnostics[J]. Journal of Sound and Vibration, 1996,190(3):399-418.
- T J Miles, M Lucast, N A Halliwell. Torsional and Bending Vibration Measurement on Rotors Using Laser Technology[J]. Journal of Sound and Vibration, 1999,226(3): 441-467.
- Hua Jianwen, Liu Liren. Study of Measurement by Torsional Vibration Transducer Type MM0071 [J]. Laser & Infrared, 1996,26(3):193-195.
- Ge Weijing, Wang Weisheng. Small Internal Combustion Engine, 1994,23(2):53-57.
- Wang Ting, Cheng Peng. Development of Computer Testing System of Crankshaft Torsional Vibration [J]. Natural Science Journal of Jilin University of Technology, 201,21(3):74-77.
- B O AL-Bedoor. Modeling the Coupled Torsional and Lateral Vibrations of Unbalanced Rotors[J]. Computer Methods in Applied Mechanics and Engineering, 2001,190: 5999-6008.

- S F Asokanathan, P A Meehans. Non-linear Vibration of a Torsional System Driven by a Hook's Joint[J]. *Journal of Sound and Vibration*, 1999,226(3):441-467.
- K Koser, F Pasin. Torsional Vibration of the Drive Shafts of Mechanisms[J]. *Journal of Sound and Vibration*, 1997,199(4):559-565.
- E Brusa, C Delprete, G Genta. Torsional Vibration of Crankshafts Effects of Non Constant Moments of Inertia[J]. *Journal of Sound and Vibration*, 1997,205(2):135-150.
- Gong Xiansheng Xie Zhijiang Tang Yike. Research on Steady Vibration Response of Shafting with Nonlinear Coupling [J]. *Chinese Journal of Mechanical Engineering*, 2001,37(6):19-23.
- Sheng Gang, Chen Zhiyan, Li Liangfeng. Torsional Vibration of the Diesel Crankshaft System with Variable Inertia [J]. *Transactions of Csice*, 1991,9(2):143-149.
- Zhu Menghua. Direct-Inverse Fourier Transformation Technique for Responses of Non-Linear Torsional Vibration of Diesel Shafting [J]. *Transactions of Csice*, 1992,10(1):47-52
- Lin Ruilin, Huang Cihao, Tang Kaiyuan. The Incremental Harmonic Balance Method for Calculating Response of Non-Linear Torsional Vibration of a Diesel Shafting [J]. *Transactions of Csice*, 2002,20(2):185-187.
- Zhang Zhihua, Tang Mi. The Numerical Computation on Torsional Vibration of Diesel Nonlinear Shafting, *Transactions of Csice*, 1987,5(4): 353-361.
- Farshidianfar A, Ebrahimi M, Bartlett H. Hybrid Modeling and Simulation of the Torsional Vibration of Vehicle Driveline Systems[J]. *Journal of Automobile Engineering*, 2001.215(4):217-229.
- Wen Bangchun, Li Yinong, Han Qingkai, Analytical Approach and Application of Nonlinear Vibration Theory [M]. Shenyang: Northeast University Press, 2001.
- Li Bozhong, Song Tianxiang, Song Xigeng. On Coupled Vibrations of Reciprocating Engine Shaft Systems(Part 1) Axial Vibration Caused by Torsional Vibration [J]. *Transactions of Csice*, 1989,7(1): 1-6.
- Li Bozhong, Song Xigeng, Song Tianxiang. On Coupled Vibrations of Reciprocating Engine Shaft Systems(Part 2)- Progressive Torsional-Axial Continued Vibrations [J]. *Transactions of Csice*, 1990,8(4):317-322.
- Song Xigeng, Song Tianxiang, Li Bozhong. On Coupled Vibrations of Reciprocating Engine Shaft Systems (Part 3)- Calculation Method of Coupled at Same and Double Frequencies [J]. *Transactions of Csice*, 1994,12(2):115-120.
- Du Hongbing, Chen Zhiyan, Jing Bo. The Mathematical Model for the Coupled Torsional-Axial Vibration of Internal Combustion Engine Shaft System[J]. *Chinese Combustion Engine Engineering* 1992,13(2):66-74.
- Zhang Yong, Jiang Zikang. Numerical Analyses of the Coupling of the Flexural and Torsional Vibrations of Rotary Shaft System[J]. *Turbine Technology*,1999,41(5): 280-283.
- Zhang Yong, Jiang Zikang. Analysis of the coupled flexural-torsional vibrations of rotary shaft systems [J]. *Journal of Tsinghua University(Science And Technology)*, 2000,40(6):80-83.
- Zhang Yong, Jiang Zikang. Mathematic model of coupled bending and torsional vibration of shaft systems [J]. *Journal of Tsinghua University(Science And Technology)*, 1998,38(8):114-117.

- Zhang Hongtian, Zhang Zhihua, LIU Zhigang. A Study on Coupled Axial and Torsional Vibration of Marine Propulsion Shafting [J]. *Shipbuilding of China*, 1995,129(2):68-76.
- Okamura H et. Simple Modeling and Analysis for Crankshaft Three-Dimensional Vibration[J]. *Journal of Vibration and Acoustics*, 1995,117(1): 70-86.
- Shen Hongbin Shu Gequn. An Investigation into Dynamic Measurement of Longitudinal/Bend/Torsional Vibration in Shaft System of Internal Combustion Engines [J]. *Small Internal Combustion Engine*, 2000, 29(6):9-10.
- Liang Xingyu, Shu Gequn, Li Donghai, Shen Yinggang. Torsional Vibration Analysis Based on Multi-body Dynamics of Flexible Crankshaft System [J]. *Chinese Combustion Engine Engineering*, In 2008, the fourth period.
- Natarajan M, Frame E A, Naegeli D, et al. Oxygenates for advanced petroleum-based diesel fuels: part1. Screening and selection methodology for the oxygenates[C]. *SAE 2001-01-3631*.
- Guo Wei-dong; Gu Wen-gang; ZhanG Xiao-ling. The Method of Compensating Division Error in Shafts Torsional Vibration Measurement and Implementation with Program [J]. *Machine Design & Research*, 2007, 23(2): 88-89.
- Zhang Xiaoling, Tang Xikuan. Analysis of torsional vibration measuring errors and their correct method [J]. *Journal Of Tsinghua University (Science And Technology)*, 1997, 37(8): 9-12.
- Xu Xintian. Measure of the torsional vibration control [J]. *Wuhan Shipbuilding*, 1999, 1:17-18.
- C T Lee, S W Shaw. The Non-linear Dynamic Response of Paired Centrifugal Pendulum Vibration Absorbers [J]. *Journal of Sound and Vibration*, 1997,203(5): 731-743.
- Weng Wenhua. Silicone Oil Damper [J]. *CCEC Science & Technology*, 1997,1:19-23.
- Luo Zhouquan. Characters of Shafting Torsional Vibration and Analysis on Damping Measures of 6180 Series Marine Engine [J]. *Design and Manufacture of Diesel Engine*, 2000, 92 (3):3-7.
- Zhou Shengfu, Li Cuncai. Function and Behaviour of Torsional Damper of Crankshaft [J]. *Vehicle Engine*, 1993,4:23-28.
- Chen Xi'en. Study on Nonlinear High-damping Dampers in calculation and measurement of torsional vibration[J], *China Ship Survey*, 1996, 1:26-32.
- Yan Jiabin. Engine Crankshaft Torsional Vibration Damper, *World Rubbre Industry*, 1998, 25(4):26-30.
- Huo Quanzhong, Liang Jie, Hao Zhiyong. Operation Principle and Experimental Study of an Active Torsional Vibration Absorber [J]. *Transactions of Csice*, 1992,10(4): 329-334.
- Hao Zhiyong, Gao Wenzhi. A Study on Active Control and Simulation Test for Torsional Vibration of Turbogenerator Shaft System [J]. *Power Engineering*, 1999,19(5): 338-341.
- Liu Shengtian. Double Mass Flywheel Type Torsional Vibration Damper [J]. *Automobile Technology*, 1997,1: 23-27.
- Liu Shengtian, Hydraulic dual-mass flywheel torsional vibration damper, [J]. *Motor Transport*,1998,9: 17-19.
- M Hosek, H Elmal, N Olgac. A Tunable Torsional Vibration Absorber: the Centrifugal Delayed Resonator[J]. *Journal of Sound and Vibration*, 1997,205(2):151-165.

- Shu Gequn, Hao Zhiyong. Experiments on the Crankshaft Torsional/Bending Vibration Damper in Internal Combustion Engine [J]. Journal of Tianjin University, 1997,30(6): 806-811.
- Shu Gequn, Lü Xingcai, Qin De, Su Yanling. Experimental Study on Hybrid Damper of HighSpeed Diesel Engine Crankshaft [J]. Transactions of Csice, 2000,20(6): 537-540.
- Shu Gequn. Effect of Bending Vibration Damper on Properties of Torsional [J]. Transactions of Csice, 1998,16(3): 348-353.
- Zhao Qian, Hao Zhiyong. Optimal Design of Torsional Damper of Diesel Engine Crankshaft System [J]. Transactions of the Chinese Society of Agricultural Machinery, 2000,31(5): 91-93.
- Song Jingbo. Internal combustion Engines, 1993, (3):38-40.
- Ying Qiguang, Bao Defu and Others. A New Fault-diagnosing Technique of Diesel Engine based on Shafting Vibration [J]. Ship Engineering, 1995, (4):33-35.
- Ying Qiguang, Li Bozhong. A New Effective Method to Diagnose the Troubles in the Technical Condition of the Diesel Engine [J]. Journal of Shanghai Maritime University, 1990, (3):20-30.
- Lin Dayuan, Wang Xu, Song Xueren. Diagnosis of Crankshaft Cracks via Measurement of Crankshaft – Flywheel System Torsional Vibration Mode [J]. Transactions of Csice, 1989, 7(3):215-222.
- Shu Gequn, Lü Xingcai. Calculation Method for Continuous Distribution Model of Torsional Vibration of a Crankshaft [J]. Transactions of The Chinese Society of Agricultural Machinery, 2004,35 (4) 36-39.

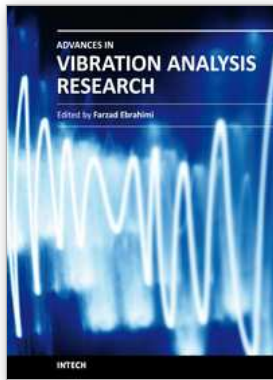

Advances in Vibration Analysis Research

Edited by Dr. Farzad Ebrahimi

ISBN 978-953-307-209-8

Hard cover, 456 pages

Publisher InTech

Published online 04, April, 2011

Published in print edition April, 2011

Vibrations are extremely important in all areas of human activities, for all sciences, technologies and industrial applications. Sometimes these Vibrations are useful but other times they are undesirable. In any case, understanding and analysis of vibrations are crucial. This book reports on the state of the art research and development findings on this very broad matter through 22 original and innovative research studies exhibiting various investigation directions. The present book is a result of contributions of experts from international scientific community working in different aspects of vibration analysis. The text is addressed not only to researchers, but also to professional engineers, students and other experts in a variety of disciplines, both academic and industrial seeking to gain a better understanding of what has been done in the field recently, and what kind of open problems are in this area.

How to reference

In order to correctly reference this scholarly work, feel free to copy and paste the following:

Liang Xingyu, Shu Gequn, Dong Lihui, Wang Bin and Yang Kang (2011). Progress and Recent Trends in the Torsional Vibration of Internal Combustion Engine, *Advances in Vibration Analysis Research*, Dr. Farzad Ebrahimi (Ed.), ISBN: 978-953-307-209-8, InTech, Available from:

<http://www.intechopen.com/books/advances-in-vibration-analysis-research/progress-and-recent-trends-in-the-torsional-vibration-of-internal-combustion-engine>

INTECH

open science | open minds

InTech Europe

University Campus STeP Ri
Slavka Krautzeka 83/A
51000 Rijeka, Croatia
Phone: +385 (51) 770 447
Fax: +385 (51) 686 166
www.intechopen.com

InTech China

Unit 405, Office Block, Hotel Equatorial Shanghai
No.65, Yan An Road (West), Shanghai, 200040, China
中国上海市延安西路65号上海国际贵都大饭店办公楼405单元
Phone: +86-21-62489820
Fax: +86-21-62489821

© 2011 The Author(s). Licensee IntechOpen. This chapter is distributed under the terms of the [Creative Commons Attribution-NonCommercial-ShareAlike-3.0 License](#), which permits use, distribution and reproduction for non-commercial purposes, provided the original is properly cited and derivative works building on this content are distributed under the same license.