

TOTAL DOSE EFFECTS ON NEGATIVE VOLTAGE REGULATOR

J. Beaucour, T. Carrière, A. Gach, D. Laxague
 MATRA MARCONI SPACE
 37, avenue Louis Breguet BP1
 78146 Velizy Villacoublay cedex - FRANCE

P. Poirot, *Consultant*

Abstract

Functional failure at low dose level (4 Krad(Si)) on voltage regulators (LM137) from different manufacturers are analysed. Dose rate effects on parts hardness are evaluated, showing that lowering the dose rate degrade more the IC's in the range 55 rad(Si)/s- 0,8 rad(Si)/s. A failure mechanism is proposed, mainly based on circuit analysis, voltage contrast measurements, local irradiation and local electrical measurements with probe station. A spice simulation was performed, providing quantitative informations on the degradation. In the light of such a failure analysis and dose rate effects, practical implications on radiation assurance are discussed.

I. INTRODUCTION

Bipolar linear IC's are usually known as quite hard parts regarding Total Dose effects, with typical dose hardness in the range 50 to 100 Krad(Si). Such a postulate comes mainly from the relative intrinsic high hardness of bipolar transistor and passive devices. The problem is that bipolar transistors and passive elements used in linear IC's are not similar to the well known elemental structures. Because of integration constraint and in order to minimise the number of mask steps during IC processing, PNP transistors are often lateral ones. Such a type of transistor is already known as Total Ionizing Dose (TID) sensitive^[1]. When using such a sensitive structure in critical function of linear IC, loss of functionality can be foreseen, as already predicted by Johnston². In this paper, we will focus on negative voltage regulator (LM137 type) from 4 different manufacturers. We will analyse the degradation mode, based on different test methods.

II. EXPERIMENTAL PROCEDURE

LM137 type parts from 4 manufacturers were irradiated with dose rate in the range 0,014 rad(Si)/s- 55 rad(Si)/s in both static ON (see fig 14) and OFF mode (all pins grounded). For low dose rate (0,014 - 0,25 rad(Si)/s) Cobalt 60 source Shepherd 484 located in MMS Vélizy plant was used. Higher dose rate (0.5 -56 rad(Si)/s) experiments were performed using

Figure (Saclay, France) panoramic Cobalt60 source of 20 000 Ci located few kilometres away from Vélizy plant. Remote testing were performed in Vélizy using LTS 2020 automatic tester from Analog Devices, Digital Signal Analyser DSA601 from Tektronic and HP4172 from Helwett Packard. Delay between irradiation and remote testing is kept below one hour. Local irradiation are performed using scanning transmission electron microscope JEOL JSM840 with electron energy up to 40 Kev. Contrast voltage potential measurement were carried out using a IDS Shlumberger tester. Probing measurements were performed using Wentworth probe station MP900 and HP4145 from Helwett Packard.

III. FAILURE DESCRIPTION

LM137 is a three terminal adjustable output negative voltage regulator. Reference voltage of -1.250V can be delivered for input voltage (referred to output voltage) ranging from -4.25V to -41.25V. The 137 circuit, shown in figure 1, consists in start up circuit, internal comparator, band gap reference, power output stage and protection circuitry.

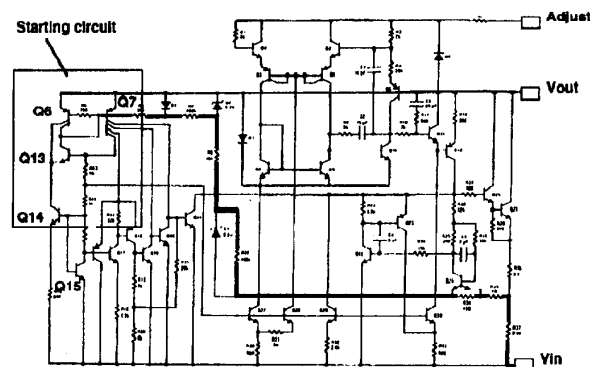

Figure 1 : Schematic diagram of LM137.

The failure is a complete loss of regulation over part or totality of the input voltage range. This is also characterised by a strong hysteresis when plotting output voltage V_{out} versus input voltage V_{in} (see figure 2). For $|V_{in}|$ larger than an input voltage threshold ($|V_{on}|$), the circuit can regulate with

only minor parametric drift in reference voltage value. For $|V_{in}|$ below $|V_{on}|$, the circuit does not regulate at all, output voltage being stuck near 0V. As soon as voltage larger than $|V_{on}|$ has been used, keeping the IC powered, the regulation can be maintained over the whole $|V_{in}|$ range, even for $|V_{in}|$ below $|V_{on}|$. This latter is what we call the hysteresis phenomena, very characteristic of the total dose degradation of 137. The characteristics V_{in}/V_{out} for degraded parts do not depend on regulated output voltage or on the output current. The curves shown on figure 2 were established using the irradiation test board where output voltage is fixed at about -11.6 V. As total dose increases, $|V_{on}|$ increases from 2V up to 45V or even more (see figure 3). In this latter case, the device can never regulate, whatever the input voltage used.

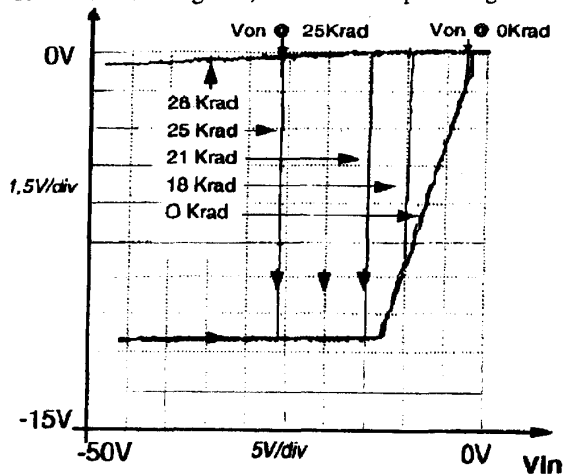

Figure 2 : Output versus input voltage plot as measured for LM137 on test board figure 14 (output voltage fixed at -11.6V). V_{on} after 0,18,21,25 and 28Krad can be read.

LM137 from manufacturers A, B, C and D were irradiated. All parts are from standard non rad hard process. For each manufacturer, V_{on} versus Dose curves obtained at low dose rate ($0,03\text{rad(Si)/s} < \text{DR} < 0,1\text{ rad(Si)/s}$) are given in figure 3. On three manufacturers A, B and C we evidenced the same functional failure mode (as shown on figure 2). On manufacturer D, only minor parametric drift was observed, without such a functional failure. The measured dose level for the first functional failure is in the range of 3 to 8 Krad(Si) for manufacturers A and B, and in the range 30 to 50 Krad(Si) for manufacturer C. We notice also a large spread in dose hardness for manufacturer A parts. For IC's coming from the same diffusion lot, we found parts with dose hardness from 4 Krad(Si) up to more than 100 Krad(Si) as shown on figure 3-a. Such a spread was observed on several diffusion lots showing that this spread can not simply be explained as a problem related to a single lot. On the other hand, we found also diffusion lot from manufacturer A with hardness larger than 100 Krad(Si), as demonstrated by testing of more than 25 parts with dose rate from $0,028\text{ rad(Si)/s}$ up to 100 rad(Si)/s . Investigations on the spread on manufacturer A parts is on going.

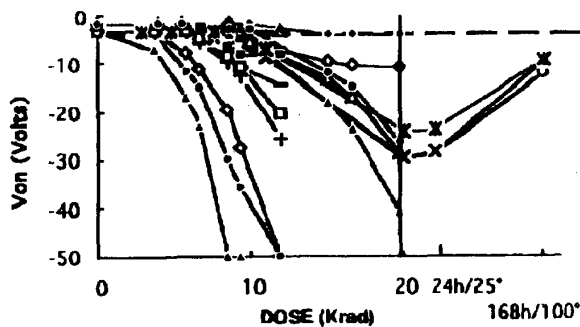

Figure 3-a. LM137-Manufacturer A parts: V_{on} versus dose.

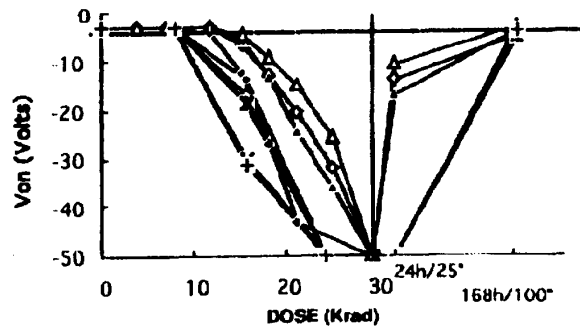

Figure 3-b. LM137-Manufacturer B parts: V_{on} versus dose.

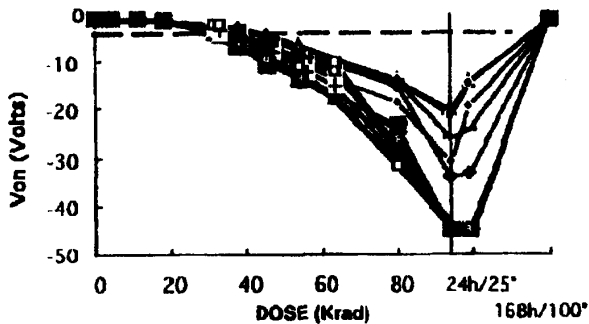

Figure 3-c. LM137-Manufacturer C parts: V_{on} versus dose .

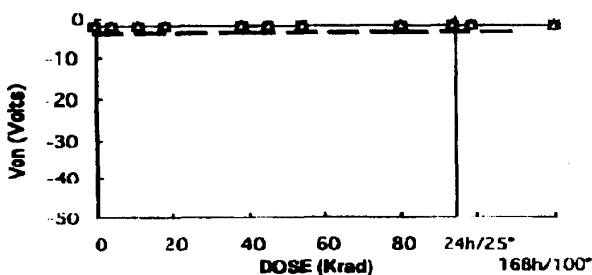

Figure 3-d. LM137-Manufacturer D parts: V_{on} versus dose.

We did not identify any very significant difference between the LM137 manufacturers design. Considering manufacturer D, we have to point out that reported result was obtained on 5 parts from a single lot. Because this manufacturer does not specifically control the critical parameters which drive the dose

hardness on bipolar linear IC's like the quality of field oxide layers, we shall remain caution on Manufacturer D LM137 hardness.

IV. DOSE RATE EFFECTS.

The curves in figures 3-a, 3-b, 3-c and 3-d are from cobalt 60 total dose irradiations at low dose rate ($0,03\text{rad}(\text{Si})/\text{s} < \text{DR} < 0,1\text{rad}(\text{Si})/\text{s}$) followed by 24H-25°C and 168H-100°C post irradiation annealing. The post irradiation annealing shows that parts from each manufacturer A, B and C recover. For manufacturer B, we noticed a significant recovery after 24H/25°C for the parts which are still measurable at the end of irradiation: Von recovery can be as large as 40 Volts. Based on the standard understanding of post irradiation effects, we could suspect an hardness improvement if dose rate is lowered. Such an improvement should be especially large for manufacturer B parts.

On the other hand, a possible non usual dose rate effect has been recently reported by Nathan Nowlin^{3,4}: worst case of dose rate for bipolar linear IC could be the lowest dose rate. Mac Clure⁵ and Johnston⁶ also showed very recently that bipolar linear IC's can degrade more at lowest dose rates. Explanation on such a dose rate effect should probably involve the modification of internal fringing fields due to the positive charge trapped within thick oxide layers above base emitter junctions⁴. Depending on dose rate, the quantity of trapped charge in thick oxide will change the fringing field, then the yield for electron-hole separation and consequently the total amount of charge deposited near Si/SiO₂ interface. Fringing field in thick oxide layer is rather low (typically below 0.5MV/cm), and fractional yield at low field for Cobalt 60 gamma rays decreases very sharply⁷, a small change in fringing field can lead to significant change in amount of trapped charges. Based on such kind of explanation, post irradiation annealing (as required by 1019.4 test procedure) can not predict low dose rate behaviour since annealing sequence only activate charges migration and recovery, but has obviously no effect on the amount of charges after irradiation.

33 Parts from a first diffusion lot from manufacturer A were irradiated, 29 at 0.028 rad(Si)/s and 4 at 8.3 rad(Si)/s. 15 (52%) from the low dose rate batch failed for dose lower than 10 Krad(Si), 3 (75%) from the high dose rate batch failed between 25 and 30 Krad(Si) and one (25%) did not fail after 30 Krad(Si).

20 parts from a second diffusion lot from manufacturer A were irradiated, 10 were tested at 0,028 rad(Si)/s and 10 at 8.3 rad(Si)/s. At lowest dose rate, 5 (50%) parts failed below 10 krad(Si), while none of the parts tested at larger dose rate showed functional failure at 30 Krad(Si). This result suggests that the 0.028 rad(Si)/s low dose rate would be worse than 8.3 rad(Si)/s. Nevertheless, a conclusion on dose rate effect based only on these results should be taken with caution since manufacturer A spread in dose hardness was always significant whatever the dose rate.

We performed a dose rate evaluation on 15 parts from the same diffusion lot from manufacturer B for which the spread in dose hardness is smaller. Since manufacturer B parts recover quickly at room temperature, we choose to explore first only high and medium dose rates range for which recovery effects can be neglected. As we saw, characteristic time for recovery effects on manufacturer B parts is close to one day so for testing at high and medium dose rate lasting one or few hours, the recovery can be neglected at first glance.

5 parts were irradiated at 55.6 rad(Si)/s, 5 parts at 8.3 rad(Si)/s, 4 parts at 0.8 rad(Si)/s. The remaining part was used as reference. Figure 4 presents the result obtained. A slight dose rate effect is observed: the lowest dose rate in this range leading to the worse results. It is noticeable that the difference between high and low dose rate is only a factor of 1 to 3 in parts hardness, which is closed to the natural spread between parts in a single diffusion lot from manufacturer B. At much lower dose rate, we foresee that such a low dose rate effect should be partially or totally compensated by the ability for manufacturer B parts to recover at room temperature. At space dose rate, manufacturer B LM137 should be harder than hardness measured using irradiation at 0.8 rad(Si)/s. It is important to keep in mind that only few types of linear IC's show a strong recovery effects as observed on LM137 from manufacturer B. The types which do not recover or which continue to degrade after post irradiation annealing will experience higher or equivalent degradation when dose rate is lowered.

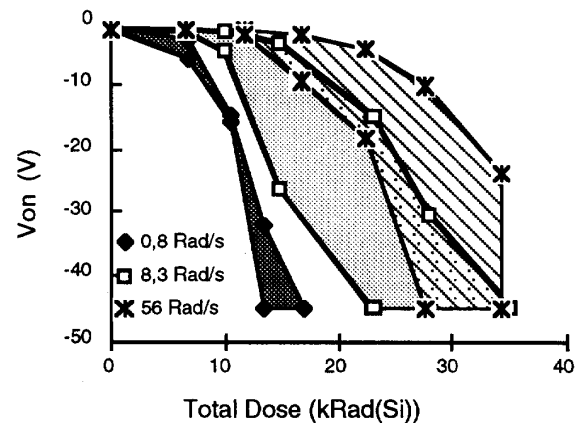

Figure 4 : Dose rate effect on LM137 from manufacturer B. The highest dose rate gives the highest hardness level.

V. FAILURE MODE.

A first analysis of the 137 circuitry was performed in order to identify potential scenario which could explain the very characteristic hysteresis. Because the device can work properly once started up, we deduced that failure should involve the start up circuitry. This latter consists in (see figure 1) two lateral multi collector PNP transistors (Q₆ and Q₇), three NPN transistors (Q₁₃, Q₁₄ and Q₁₅) a series of resistors and diodes

(D1). By increasing the input voltage, the base current of Q7 increases through the series of resistors, switches on Q7 so that Q7 collector current is large enough to bias the attached transistors. Then, an internal loop generated by NPN Q13 and PNP Q7 allows the base current of Q7 to be fixed at a given value, whatever the input voltage, and the whole circuit is biased. Q7 and Q13 form a thyristor which remains in low impedance mode whatever the input voltage provided it was started-up. The steady state value of Q7 base current is defined by the relative geometry of Q13, Q14 and Q15 NPN transistors. From this analysis, we identify that IC failure could come from a failure in start up circuit due to a gain decrease in lateral PNP such as Q7.

Failure analysis has been performed first by contrast voltage potential measurement. Because the voltage contrast within linear IC is quite small, the voltage contrast measurement can provide only qualitative informations on the most affected parts. We used this characterisation method to have a first idea about the failure mode considering the whole circuit. Voltage contrast on one irradiated part from manufacturer A between functional ($|V_{in}| > |V_{on}|$) and non functional ($|V_{in}| < |V_{on}|$) states exhibits that the current source supplied by the start-up circuit is not triggered in the non functional state (see figure 5). It is then concluded that either the base current of both Q28 and Q30 is too small or the gain of Q28 and Q30 is too damaged.

In this latter failure mode, we should not have any hysteresis : when input voltage is decreased below the threshold voltage $|V_{on}|$, the regulation should fail again, which is not the observation. If we consider the second failure mode (base current too small), we can qualitatively explain the hysteresis . The base current of Q28 and Q30 is directly a part of the collector current of Q7 lateral PNP. When Q7 is switched ON, its collector current increases to a value which allows proper biasing of Q28 and Q30. When input voltage is decreased, the currents remain unchanged since Q7 base current is now maintained through the Q7/Q13 thyristor in steady state low impedance mode. Consequently, Q28 and Q30 can remain properly biased when input voltage decreases below input voltage threshold $|V_{on}|$ as long as Q7/Q13 thyristor remain ON.

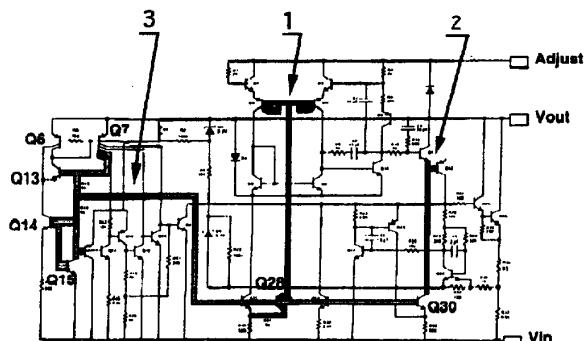

Figure 5 : Voltage contrast is observed on line 1 and 2. Notice that collector current of Q6 and Q7 feeds Q28 and Q30 (line 3).

At this stage of investigations, we have to confirm that failure is mainly driven by Q7 degradation. To reach this goal, we undertook local irradiation using a 40 KeV scanning electron microscope.

Irradiation was performed on 4 different parts from manufacturer A. A first part was entirely irradiated in order to verify that electron irradiation induced the same failure mode than Cobalt 60. The typical hysteresis was clearly reproduced and the shape of the degradation curve V_{on} versus Dose is similar to the curves obtained after cobalt 60 irradiation. Then, we irradiated the Q7 area (see figure 6, area 1). We obtained the same kind of functional failure, with the typical hysteresis phenomena and a $V_{on}/Dose$ degradation curve similar to the curve obtained for the whole device irradiation (see figure 7). Finally, we irradiated all the area of the IC that we could identify as not being part of the start-up circuit (area 2). In this case, we did not degrade the parts, the IC remaining functional over the full range of input voltage (V_{on} closed to -2V).

To be exhaustive, we have to mention that we also irradiated another part of the start up circuit which does not included Q7 and observed again functional failure with hysteresis but for larger dose levels. We attribute this non dominant failure mode to the gain degradation of multicollector PNP lateral Q6 and NPN Q13.

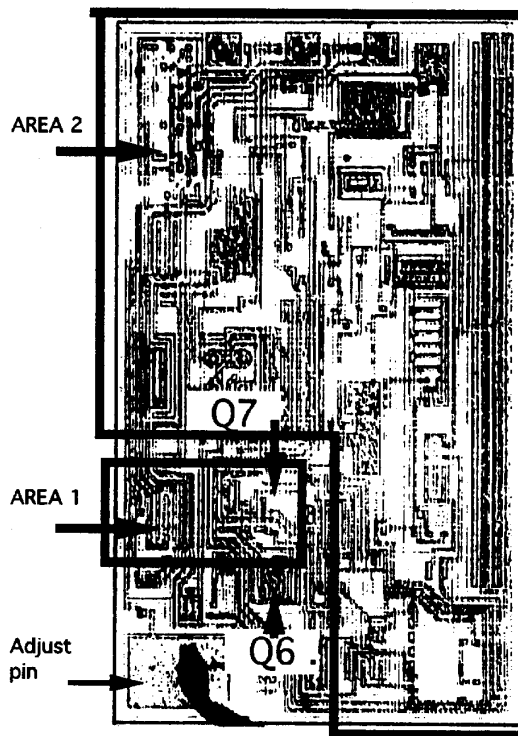

Figure 6 : Irradiated area (manufacturer A die). Area 1 contains Q7, while Area 2 does not content critical transistors of start-up circuit.

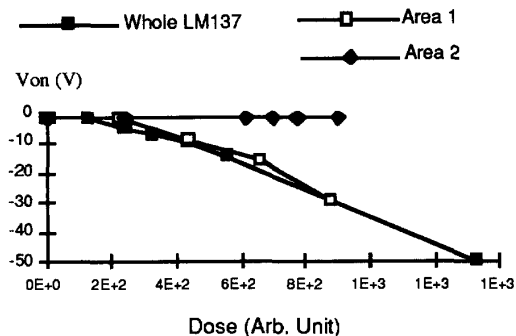

Figure 7 : Local irradiation on LM137 from manufacturer A. Failure can be reproduced when Q_7 is irradiated.

From local irradiation, we deduced that IC failure can be attributed to the failure of start up circuit which can not provide the current able to bias the rest of the IC. This can come either from a gain decrease of PNP Q_7 & Q_6 or (most unlikely) from an increase of the value of pinch off resistors R of start-up circuit. In this latter case, the increase of input voltage does not increase the base current I_b of Q_7 since $I_b(Q_7) = V_{in}/R$. The values of resistor, and especially the value of the 100 Kohms, were checked by direct probing on parts from manufacturer B. No large drift was evidenced, so that we suspected that start up circuit failure should mainly come from gain degradation of Q_7 PNP transistor.

In order to confirm the link between the start up circuit failure and the current gain degradation of Q_6 and Q_7 PNP transistors, the failure analysis was complemented by probing measurements of current gain β on Q_6 and Q_7 . This analysis was performed on manufacturer B parts. The figures 8 and 9 present the curves $\beta(I_c)$ at $V_{ce} = -5V$ respectively for Q_6 and Q_7 .

Similar degradation is observed on Q_6 and Q_7 : gains clearly decrease over the whole collector current range as dose increase. The typical Q_6 & Q_7 collector current required by LM137 to work properly is about 100 μA . From figure 8 and 9, the gains measured for this collector current are 17 ± 1 (Q_6) and 22 ± 1 (Q_7) for the control device S/N1. β on S/N2 (irradiated up to 8Krad with $V_{on} = -4V$) dropped down to 10 ± 1 (Q_6) and 8 ± 0.5 (Q_7).; On the most deteriorated part S/N3 (irradiated up to 15Krad with $V_{on} = -46V$) gains were 5 ± 0.5 (Q_6) and 3.5 ± 0.5 (Q_7).

Probing measurements showed clearly a relation between the increase of input threshold voltage V_{on} and the decrease of current gain β on Q_6 and Q_7 PNP transistors. It is worth to note that β has to be sufficiently low to produce significant V_{on} increase. When gain is below 10, a small additional gain decrease leads to a sharp increase in V_{on} . We can also notice that Q_6 degradation is faster than Q_7 one. Q_7 geometry could explain this observation, Q_7 being especially large PNP lateral multicollector transistor.

Probing measurements are in agreement with the assumption that Q_6 and Q_7 gain decrease plays a key role in the IC failure.

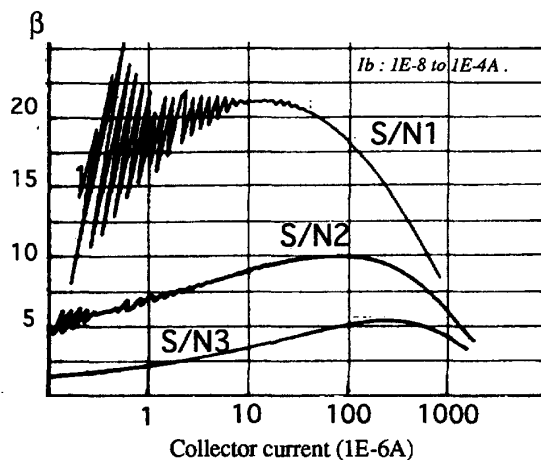

Figure 8 : Measurement of $\beta(I_c)$ of Q_6 PNP transistor. 3 parts were measured : S/N1 (control, $V_{on} = -1.5V$), S/N2 (irradiated up to 8 Krad[Si], $V_{on} = -4V$) and S/N3 (irradiated up to 15 Krad[Si], $V_{on} = -46V$).

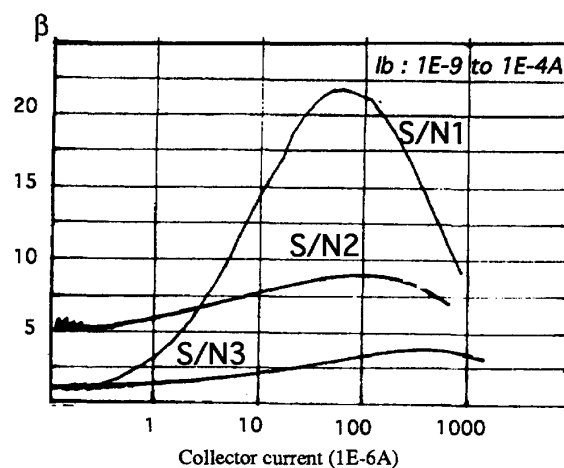

Figure 9 : Measurement of $\beta(I_c)$ of Q_7 PNP transistor. 3 parts were measured : S/N1 (control, $V_{on} = -1.5V$), S/N2 (irradiated up to 8 Krad[Si], $V_{on} = -4V$) and S/N3 (irradiated up to 15 Krad[Si], $V_{on} = -46V$).

VI. CIRCUIT SIMULATIONS.

In order to make definitive statement on the origin of the LM137 functional failure, we performed simulations of the effect of radiation on 137 degradation. Spice simulator was used and only the start up circuit was simulated (see figure 10). Multicollector transistors were simulated as being several standard transistors with their emitters and their bases connected. Large signal model transistor used is to the Gummel-Poon model. Gain degradation is modelled as an increase of recombination contribution I_r in total base current I_b . I_i is the ideal base current.

$$I_b = I_i + I_r$$

$$I_i = I_{i0} \exp \frac{qV_{BE}}{k_B T}$$

$$I_r = I_{r0} \exp \frac{qV_{BE}}{2k_B T}$$

The geometry of each transistors and diodes of start up circuit were given by manufacturer B. Figure 11 shows the simulation of Q7 collector response when Q7 gain is decreased. Before irradiation, a slight increase in V_{in} of about 1 volt is large enough to switch on Q7. After a decrease of Q7 gain, Q7 can be switched on only for V_{in} larger than a minimum voltage. Then emitter and collector current sharply increase (2 order of magnitude). As qualitatively foreseen, a large enough gain degradation on Q7 retains starting circuit to provide proper current to the rest of the IC. Such an effect appears for gain smaller than a typical value of 8.

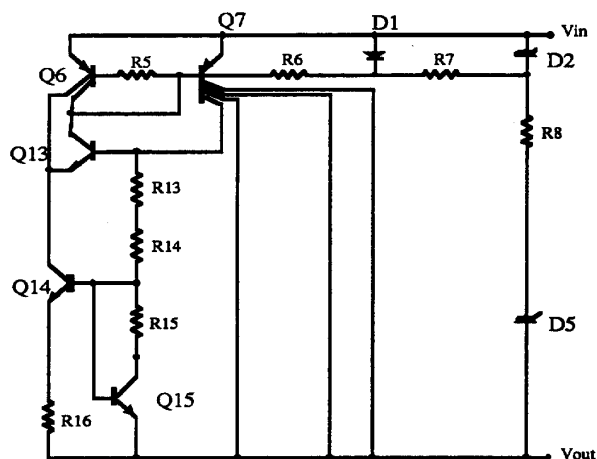

Figure 10 : Schematic of start-up circuit simulated .

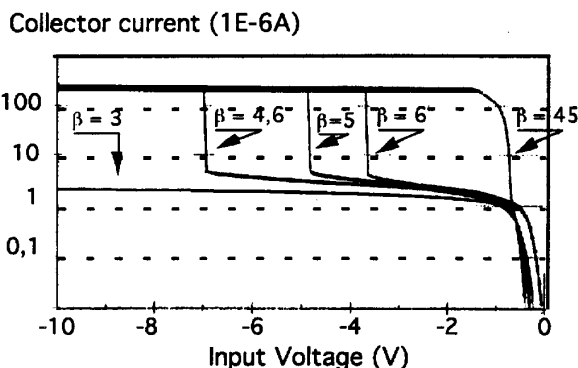

Figure 11 : Start-up circuit simulation : collector current of Q7 when gain (β) is decreased. For low gain, a minimum input voltage is required in order to start up Q7. Similar curve were obtained for Q6 collector current.

Figure 12 shows simulation of the V_{on} drift versus reciprocal gain variation $\Delta(1/\beta)$. We can notice the similar shape

between curves figures 12 and 3. This result is consistent with linear degradation of $\Delta(1/\beta)$ with total dose. On the figure 13, we simulate a progressive increase and decrease of input voltage in order to reproduce the experimental hysteresis. As can be seen, the input voltage threshold is the same for both Q6 and Q7. At larger $|V_{in}|$ than $|V_{on}|$, starting circuit is able to start up the whole device to make it regulate properly. Figure 13 is to be compared with figure 2 showing the experimental signature of the failure.

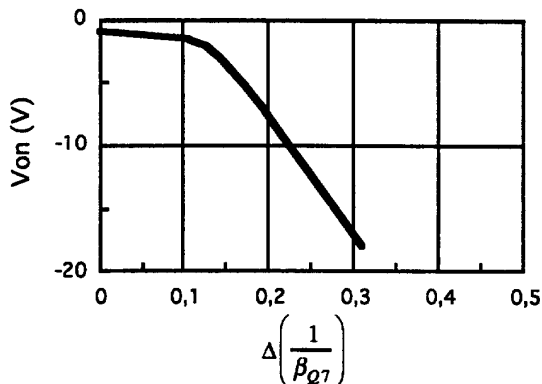

Figure 12 : Start-up circuit simulation : Q7 reciprocal gain decrease effect on V_{on} . Shape of this curve can be compared to experimental results of figure 3.

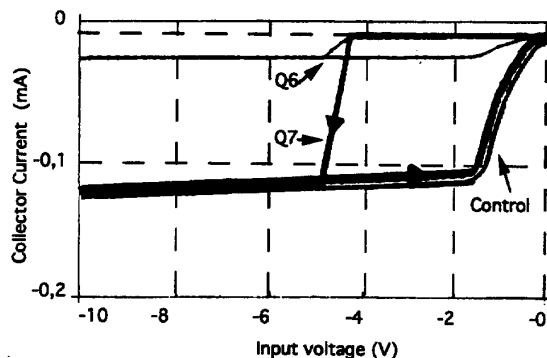

Figure 13 : Simulation of start-up circuit. Q7 and Q6 collector current changes ($\beta_{Q6}=\beta_{Q7}=5$) when input voltage is increased and then decreased. The hysteresis experimentally observed is clearly reproduced.

VII. BIAS EFFECTS DURING IRRADIATION.

137 were irradiated with two different biasing conditions. The first one is a static off case, with all pins grounded. The second one is a static on case (see figure 14). Difference in dose hardness between these two modes is comparable with the accuracy of the measurement. This is in accordance with previous test⁸ on many bipolar linear IC. This result is also in accordance to previous publications³ on test vehicle

irradiations showing only minor effects of biasing conditions. This can be also understood keeping in mind the failure mode presented in previous sections. Internal fringing field near Q7 PNP transistor emitter-base junction is the key parameter which lead the dose hardness. Since bias of this junction can not be largely modified by external bias, the bias mode during irradiation can not have large consequences on parts hardness.

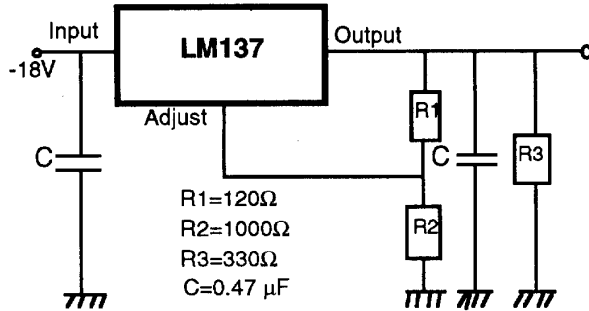

Figure 14: Static on bias condition used for irradiation and V_{in}/V_{out} characterisation. Notice that resistor network fix output voltage to $-11,6V$.

VIII. DISCUSSION

The dose rate responses of LM137 from manufacturer A and B follow the trend observed by several author on individual bipolar transistors and linear IC's^{5,6,9}, where low dose rate leads to poorer dose hardness. In this paper, a slight degradation of the hardness is observed when dose rate is lowered for dose rates in the range $55 \text{ rad(Si)/s} - 0.8 \text{ rad(Si)/s}$. On the other hand, the space low dose rate ($1E-4 \text{ rad(Si)/s}$) is not necessarily the absolute worst dose rate as it can be speculated from post irradiation data obtained on manufacturer B. We can foresee that linear IC's showing strong recovery during a 25°C annealing could exhibit a peak in their dose rate response, their dose sensitivity being the highest at a medium or low dose rate. Intrinsic dose rate effect will have to compete with the well known charge trapping recovery so that a peak in dose rate behaviour can be foreseen.

For a practical point of view, the ability for parts to recover at room temperature could be a good indication that laboratory dose rate will cover the space low dose rate and avoid to use additional margin to account for a possible worse degradation at space dose rate.

Considering the failure mode of LM137, we evidenced the key function of lateral PNP on the IC failure. Lateral PNP gain degradation should also affect other linear IC's, as already reported by Johnston². Detailed informations on lateral PNP transistors degradation and investigations on their failure mode is one of the key to properly understand and predict failure levels of complex linear IC's. Other regulators based on a starting circuit driven by lateral PNP should be good candidate for early failure under irradiation.

IX. CONCLUSIONS

Functional failure of highly dose sensitive LM137 was deeply investigated and shows that the weakest part of the IC are the lateral multi collector PNP transistors driving the start-up circuit. IC failure is due to a gain degradation below typical value of 8 on these transistors. Hardening of LM137 should involve design changes in the start up circuit in order to make it more tolerant to a gain drop in conjunction with standard oxide hardening and control.

Low dose rate testing should be preferred for irradiation of linear IC's. Post irradiation annealing results as per 1019.4 or ESA/SCC22900.3 could be used to determine if laboratory dose rate is the worst case dose rate or not and do not seems to be able to predict quantitatively space dose rate behaviour for bipolar linear IC's.

X. ACKNOWLEDGEMENTS

We would like to thanks the Motorola- Toulouse engineering team for fruitful discussions and technical support toward the understanding of the 137 failure mode.

XI. REFERENCES

- ¹ L. J. Palkuti, L.L. Silvo, R.B. Greeger, IEEE Trans on Nucl. Sci. , Vol. NS23, N°6, Dec 1976.
- ² A.H. Johnston, R.E Plaag, IEEE Trans on Nucl. Sci. Vol. NS-34, N°6 Dec. 1987 p1474.
- ³ R. Nathan Nowlin, EW Enlow, RD Schrimpf, WE Combs; IEEE Trans on Nuc. Sci. Vol 39, N°6, Dec 1992, p.2026.
- ⁴ R. Nathan Nowlin, DM Fleetwood, RD Schrimpf, RL Pease, WE Combs . IEEE Trans on Nuc. Sci. Vol 40, N°6, Dec 1993, p.1686.
- ⁵ S. Mac Clure and R.L. Pease, to be published in IEEE Trans. on Nucl. Sci N°6, Dec. 1994.
- ⁶ A. H. Johnston, G. W. Swift, B. G. Rax, to be published in IEEE Trans. on Nucl. Sci N°6, Dec. 1994.
- ⁷ T. R. Oldham and J M Garrity IEEE Trans on Nuc. Sci. Vol 30, N°6, Dec. 1983)
- ⁸ MMS internal test report on LM111, 124, 117, 108, 139.
- ⁹ D. M. Fleetwood, S. L. Kosier, R.N. Nowlin, R.D. Schrimpf, R.A. Rebe Jr., M. De Laus, P.S. Winokur, A.Wei, W.E. Combs, R.L. Pease , To be published in IEEE Trans. on Nucl. Sci N°6, Dec. 1994