

Experimental Investigation of S-Band CP Antenna with Perturbed Corners for a Rectenna Circuit

[#]Mazlina Esa, Ikhwan Peranggi Pohan and Jasmy Yunus
Faculty of Electrical Engineering, Universiti Teknologi Malaysia,
81310 UTM Skudai, Johor, Malaysia, mazlina.esa@ieee.org

1. Introduction

A receiving antenna can be integrated at its front-end with low-pass filtering and rectifying circuits, forming the rectenna or rectifying antenna system. It allows power to be delivered through wireless using microwave frequency and be converted back into electricity [1], [2]. The filtering is needed to pass the fundamental frequency whilst rejecting a portion of the higher order harmonics generated from the rectifying circuit [2]. The S-band has been in consideration for the wireless (WPT) or microwave power transmission (MPT) due to its location in the unlicensed band. The converted electricity can be used for energy storage or charging a device. Several rectenna candidates [3]-[6] have been reported. This paper presents the experimental investigation of the designed circularly polarized truncated square patch antenna at 2.45 GHz that employs perturbed corner slits. Initial successful numerical investigations have been reported in [7]-[9].

2. Designed Antenna with Perturbed Corners

The basis of the antenna is the basic square patch configuration that is linearly polarized. It is designed using formulae available in the literature [10]-[11]. By employing truncation at the two opposite edges, the desired right-hand circular polarization (RHCP) can be achieved. Hence, the needs for specific antenna orientation can be avoided. Perturbations were done on all corners using slits so as to reduce the resonant frequency, thus making the resonant antenna more compact. The antenna is fed using electromagnetic coupling (EMC) method, with its feed location as that of a probe-fed [10]-[11]. Such feed allows no direct soldering to the radiating patch, thus avoiding any radiation power loss. The antenna with optimum feed is named SCTSP_E3 and is shown in Figure 1(a). It has been successfully numerically simulated [7]-[9] using em simulation software [12].

The simulated SCTSP_E3 antenna was found to perform optimally when $L = 23$ mm, $c = 2.5$ mm, $l_{sl} = 11.2$ mm with maximum current density along the patch edges is 15.2 Amps/m as depicted in Fig. 1(b). The antenna resonates well at 2.45 GHz with good return loss of -20.47 dB, voltage standing wave ratio, VSWR of 1.21, and exhibits narrow VSWR bandwidth of 0.75%. Good axial ratio, AR of 1.36 dB and the corresponding RHCP bandwidth is 0.19 %. The simulated gain is 3.73 dBi, identical half-power beamwidths, HPBWs, are 107° and 109° for the E - and H -plane, respectively. These are shown in Figs. 2 and 3. The simulated gain agrees with theory and HPBWs are in the range of a typical square patch microstrip antenna [13].

The antenna is first scaled up to 1.6 GHz due to the limitation of the experimental set-up of 1.2 GHz to 1.8 GHz. The antenna is named SCTSP_E2. It resonates well at 1.637 GHz with good return loss of -16.15 dB, VSWR of 1.37, and exhibits narrow VSWR bandwidth of 0.62%. Good axial ratio, AR of 1.5 dB was observed and the corresponding RHCP bandwidth is 0.16 %. The simulated gain is 3.47 dBi, similar HPBWs of 110° and 105° for the E - and H -plane, respectively, and maximum current density along the patch edges is 11.51 Amps/m.

3. Experimental Investigations of SCTSP_E2 Antenna

The SCTSP_E2 antenna has been successfully measured using AntennaLab measurement system. A broadband Yagi-Uda array was used as reference. The return loss performance is shown

in Fig. 4. The measured return loss of the SCTSP_E2 antenna is shown in Fig. 5. It can be seen that the antenna operates well at 1.76 GHz with good return loss of -16 dB, VSWR of 1.38, and exhibits narrow VSWR bandwidth of 13 MHz or 0.77%. The resonance shifted slightly by 7.5 %, compared to the simulated results. The corresponding measured far-field *E*- and *H*-plane co-polarization radiation patterns are similar as shown in Figs. 6 and 7. In the *E*-plane, the maximum $|S_{21}|$ at broadside was -23.5 dB while the minimum was -26.5 dB. In the *H*-plane, the maximum $|S_{21}|$ at broadside was -24.5 dB while the minimum was -27.5 dB. Hence, the measured AR is computed as 27.5 dB – 23.5 dB = 4 dB. This is slightly above the desired 3 dB value. For the orientations of 0°, 45° and 90°, the measured *E*-plane HPBWs are 100°, 95°, and 75°, respectively. The corresponding measured *H*-plane HPBWs are 75°, 105°, and 75°, respectively. These HPBWs are broad, as expected.

4. Conclusions and Future Work

The measured performances of a modified truncated square patch antenna with electromagnetic coupling feed operating at S-band have been presented. The antenna is compact in size and exhibits circular polarization. It was found that the antenna operates well at its desired frequency of operation.

Acknowledgments

The authors acknowledge the support of Universiti Teknologi Malaysia and Fundamental Research Grant Scheme Vote 78024, Ministry of Higher Education, Malaysia.

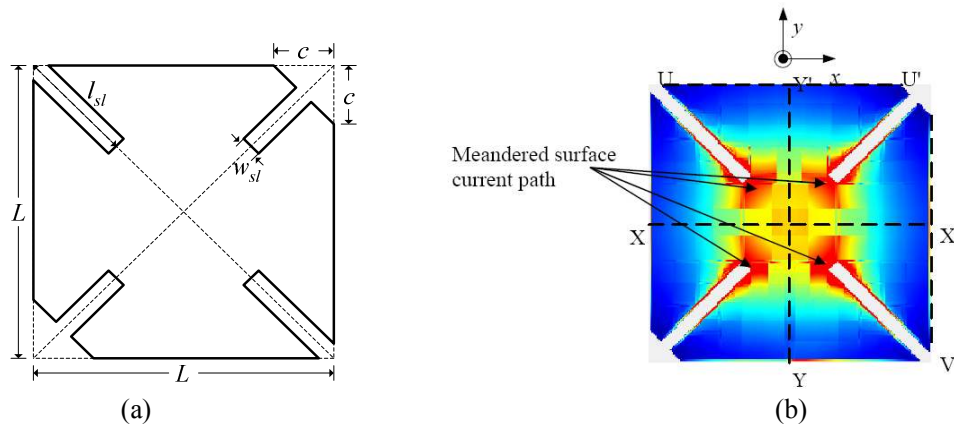

Fig. 1: SCTSP_E3 antenna (a) geometry (b) simulated current distribution.

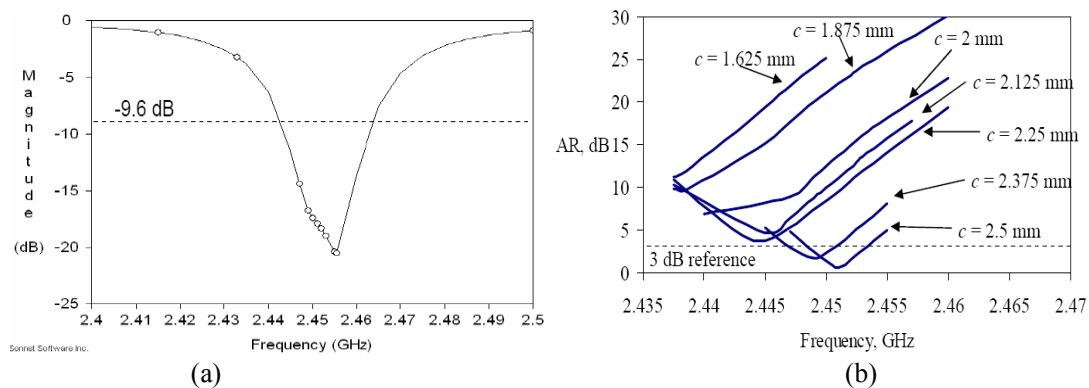

Fig. 2: Simulated (a) return loss (b) AR of SCTSP_E3 antenna.

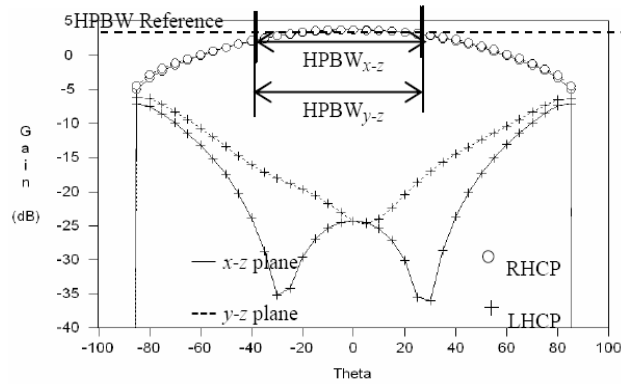

Fig. 3: Simulated radiation patterns in the x - z and y - z plane of SCTSP_E3 antenna.

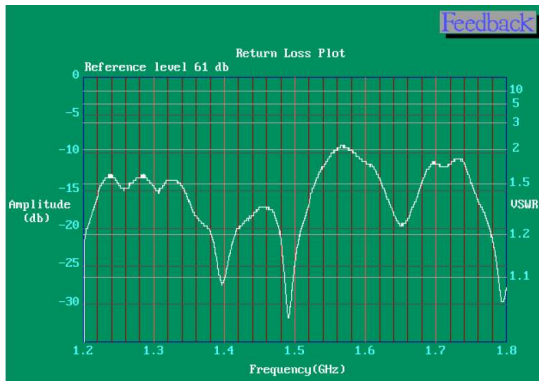

Fig. 4. Measured return loss of Yagi-Uda array.



Fig. 5. Measured return loss of SCTSP_E2.

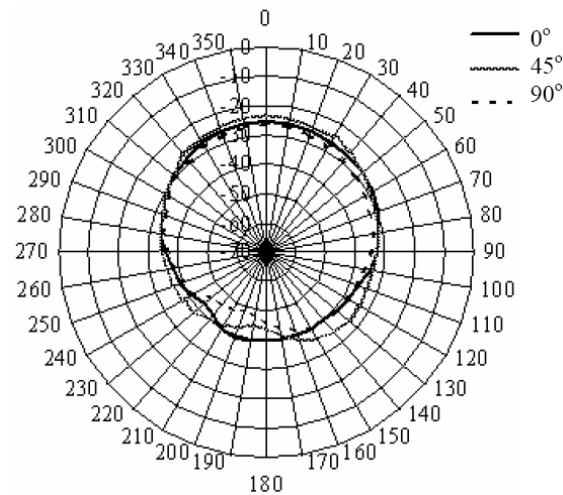

Fig. 6. Measured E -plane radiation patterns of SCTSP_E2 antenna with three oriented rotations.

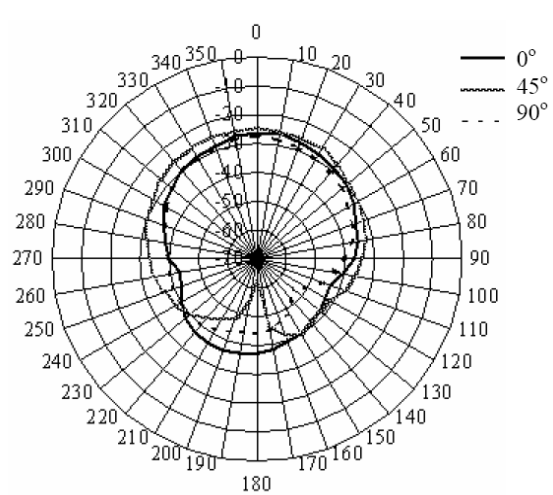

Fig. 7. Measured H -plane radiation patterns of SCTSP_E2 antenna with three oriented rotations.

References

- [1] N. Tesla, "The transmission of electric energy without wires", The 13th Anniversary Number of the Electrical World and Engineer, 1904.

- [2] Hiroshi Matsumoto, "Research on Solar Power Satellite and Microwave Power Transmission in Japan", IEE Microwave Magazine, vol. 3, 2004.
- [3] Yoo, T., McSpadden, J. O. and Chang, K., "35 GHz rectenna implemented with a patch and a microstrip dipole antenna", IEEE MTT-S Digest, vol. 1, pp.345-347, 1992.
- [4] McSpadden, J. O. and Chang, K., "A dual polarized circular patch rectifying antenna at 2.45 GHz for microwave power conversion and detection", IEEE MTT-S Int. Microwave Symp. Dig, 3, pp.1749-1752, 1998.
- [5] Suh, Y. H., Wang, C., and Chang, K., "Circularly polarized truncated-corner square patch microstrip rectenna for wireless power transmission", Electronics Letters, vol. 36, no.7, pp.600-602, 2000.
- [6] Fujino, Y., Kaya, N., and Saka, T., "Development of C-band rectenna for microwave power transmission toward a space robot", Acta Astronautica, vol. 50, pp.295-300, 2002.
- [7] Mazlina Esa, Noor Asniza Murad, Ikhwan Peranggi Pohan, Rosmawati Othman and Adnall Bakar, "Modified Bifin Fractal Antenna with Size Reduction", Proc of 2004 Radio Frequency and Microwaves (RFM2004), Subang, Malaysia, 4 pp, 4-6 Oct 2004.
- [8] Mazlina Esa, Ikhwan Peranggi Pohan, Jasmy Yunus and Noor Asniza Murad, "Modified Truncated Patch Antenna for S-Band Wireless Power Transmission Rectenna", Proc. of Int. Symp. on Ant. and Propag., Singapore, 4 pp, 2006.
- [9] Mazlina Esa, Ikhwan Peranggi Pohan, and Jasmy Yunus, "Printed Antenna with Quad L-Shaped Perturbed Slits for S-Band", Proc. of Int. Workshop on Antennas Technology, Chiba, Japan, 4 pp, 2008.
- [10] C. A. Balanis, *Antenna Theory and Design*, Wiley, 3rd edn, 2005.
- [11] David M. Pozar, *Microwave Engineering*, 3rd Ed, Wiley, New York, 2005.
- [12] <http://www.sonnetusa.com>
- [13] D. M. Pozar, and D. H. Schaubert, "The Analysis and Design of Microstrip Antennas and Arrays", A Selected Reprint Volume. IEEE Antennas and Propagation Society Sponsor. New York, 1995.