

VOLTAGE-MODE UNIVERSAL BIQUADRATIC FILTER USING TWO OTAs

JIUN-WEI HORNG*

*Department of Electronic Engineering, Chung Yuan Christian University,
Chung-Li, 32023, Taiwan, R.O.C.*

(Received 26 January 2003; In final form 21 March 2003)

A four-inputs and two-outputs voltage-mode universal biquadratic filter using only two operational transconductance amplifiers (OTAs) and two capacitors is presented. The new circuits offer several advantages, such as employing the minimum number of active and passive components (two OTAs and two capacitors); the versatility to synthesize highpass, bandpass, lowpass, notch and allpass responses; high input impedance and employing only grounded capacitors for bandpass and lowpass filter realizations; some derived filter types enjoy the availability of one more simultaneously output filter response and good sensitivities performance.

Keywords: OTA; Universal biquadratic filter; Voltage-mode

1 INTRODUCTION

The design of filter circuits employing active devices such as current conveyors (CCs) and operational transconductance amplifiers (OTAs) has been reported in the literature [1–14]. An OTA provides a high linear electronic tunability and a wide tunable range of its transconductance gain. Moreover, OTA-based filters require no resistors, hence they are more suitable for monolithic integration than the CC-based ones. These features are very attractive to filter designers.

In 1986, Nawrocki and Klein proposed a voltage-mode universal biquadratic filter with single input and single output using eight OTAs and two capacitors [6]. In 1992, Khan *et al.* proposed two configurations for realizing voltage-mode universal biquadratic filters each with three inputs and single output using three OTAs, one voltage follower and two capacitors [7]. In 1993, Sun and Fidler proposed a single-input and single-output voltage-mode universal biquadratic filter by using six OTAs and two capacitors [8]. In 1993, Wu and Xie proposed a five-inputs and three-outputs voltage-mode multifunction filter by using four OTAs and two capacitors [9]. In 1994, Al-Ali *et al.* used the circuit proposed by Wu and Xie [9] to implement the programmable multifunction filter [10]. However, these configurations [6–10] employ too many active components.

* E-mail: jwhorng@cycu.edu.tw

Recently, multiple current outputs OTAs have been used for designing active filters [11–14]. In 1999, Chang proposed three configurations for realizing voltage-mode biquadratic filters using multiple current outputs OTAs [14]. The first was a configuration with single input and three outputs using three OTAs and two capacitors that can realize notch, lowpass and bandpass filters. The second was a configuration with single input and three outputs using three OTAs and two capacitors that can realize highpass, bandpass and lowpass filters. The third was a configuration with two inputs and two outputs using two OTAs and two capacitors that can realize notch, highpass, bandpass and lowpass filters. However, some standard filter types cannot be obtained in each proposed configuration.

In this paper, a new voltage-mode universal biquadratic filter with four inputs and two outputs using two multiple current outputs OTAs and two capacitors is proposed. The proposed circuit can realize all the standard filter functions, that is, highpass, bandpass, lowpass, notch and allpass filters from the same configuration. It has the advantages of high input impedance and employing only grounded capacitors for bandpass and lowpass filter realizations. Some derived filter types enjoy the availability of one more simultaneously output filter response.

2 CIRCUIT DESCRIPTIONS

The proposed circuit is shown in Figure 1. The multiple current outputs OTA is a set of differential voltage controlled current sources. The output voltage V_{o1} and V_{o2} can be expressed as

$$V_{o1} = \frac{s^2 C_1 C_2 V_3 + s C_1 (g_1 V_1 + g_2 V_2 - g_2 V_4) + g_1 g_2 V_1}{s^2 C_1 C_2 + s C_1 g_1 + g_1 g_2} \quad (1)$$

$$V_{o2} = \frac{s^2 C_1 C_2 V_4 + s g_1 (C_1 V_4 + C_2 V_3 - C_2 V_1) + g_1 g_2 V_2}{s^2 C_1 C_2 + s C_1 g_1 + g_1 g_2}. \quad (2)$$

From Eqs. (1) and (2), we can see that:

- (1) If $V_1 = V_2 = V_4 = 0$ (grounded) and $V_3 =$ input voltage signal, a non-inverting highpass filter can be obtained at V_{o1} and a non-inverting bandpass filter can be obtained at V_{o2} ;
- (2) If $V_1 = V_3 = V_4 = 0$ (grounded) and $V_2 =$ input voltage signal, a non-inverting bandpass filter can be obtained at V_{o1} and a non-inverting lowpass filter can be obtained at V_{o2} ;

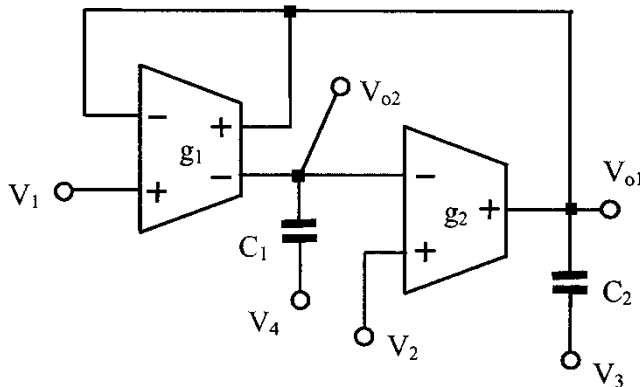

FIGURE 1 The proposed voltage-mode universal biquad.

- (3) If $V_1 = V_2 = V_3 = 0$ (grounded) and $V_4 =$ input voltage signal, an inverting bandpass filter can be obtained at V_{o1} ;
- (4) If $V_2 = V_3 = 0$ (grounded), $g_2 = g_1$, $C_2 = C_1$ and $V_1 = V_4 =$ input voltage signal, a non-inverting lowpass filter can be obtained at V_{o1} and a non-inverting highpass filter can be obtained at V_{o2} ;
- (5) If $V_2 = 0$ (grounded), $g_2 = g_1$ and $V_1 = V_3 = V_4 =$ input voltage signal, a non-inverting notch filter can be obtained at V_{o1} ;
- (6) If $V_2 = 0$ (grounded), $g_2 = 2g_1$ and $V_1 = V_3 = V_4 =$ input voltage signal, a non-inverting allpass filter can be obtained at V_{o1} ;
- (7) If $V_2 = V_3 = V_4 = 0$ (grounded) and $V_1 =$ input voltage signal, an inverting bandpass filter can be obtained at V_{o2} ;
- (8) If $V_3 = 0$ (grounded), $C_2 = C_1$ and $V_1 = V_2 = V_4 =$ input voltage signal, a non-inverting notch filter can be obtained at V_{o2} ;
- (9) if $V_3 = 0$ (grounded), $C_2 = 2C_1$ and $V_1 = V_2 = V_4 =$ input voltage signal, a non-inverting allpass filter can be obtained at V_{o2} .

Thus, the circuit is capable of realizing all filter functions. The circuit requires the minimum number of active and passive components. The input signals, V_1 and V_2 , are connected to the high input impedance input nodes of the OTAs. So the circuit enjoys the advantages of having high input impedance and employing only grounding capacitors for bandpass and lowpass realizations in filter types (2) and (7). The use of only grounded capacitors is attractive for integrated circuit implementation [5, 8]. Moreover, the allpass realizations in filter types (6) and (9) need not one more active component for unity-gain inverting input. Furthermore, some derived filter types (type (1), (2) and (4)) enjoy the availability of one more simultaneously output filter response.

From Eqs. (1) and (2), the parameters ω_o , Q can be expressed as

$$\omega_o = \sqrt{\frac{g_1 g_2}{C_1 C_2}} \quad (3)$$

$$Q = \sqrt{\frac{C_2 g_2}{C_1 g_1}}. \quad (4)$$

The active and passive sensitivities of this universal filter are

$$S_{g_1 g_2}^{\omega_o} = -S_{C_1 C_2}^{\omega_o} = \frac{1}{2}, \quad S_{C_2 g_2}^Q = -S_{C_1 g_1}^Q = \frac{1}{2}.$$

3 SIMULATION RESULTS

PSPICE simulations were carried out to verify the potentialities of the proposed circuit. The CA3080 OTA macro model with $R_i = 100 \text{ k}\Omega$, $R_o = 70 \text{ M}\Omega$, $C_i = 2.6 \text{ pF}$, $C_o = 3.6 \text{ pF}$ was used. Figure 2 shows the simulation results for the bandpass and lowpass filters in Figure 1, which was designed with $V_1 = V_3 = V_4 = 0$ (grounded), $V_2 =$ input voltage signal, $C_1 = C_2 = 10 \text{ nF}$ and $g_1 = g_2 = 1 \text{ mS}$. Figure 3 shows the simulation results for the allpass filter in Figure 1 at V_{o2} , which was designed with $V_3 = 0$ (grounded), $V_1 = V_2 = V_4 =$ input voltage signal, $C_1 = 10 \text{ nF}$, $C_2 = 20 \text{ nF}$ and $g_1 = g_2 = 1 \text{ mS}$. In the simulations, the multiple current output OTAs were constructed by using single-ended OTAs in parallel connection.

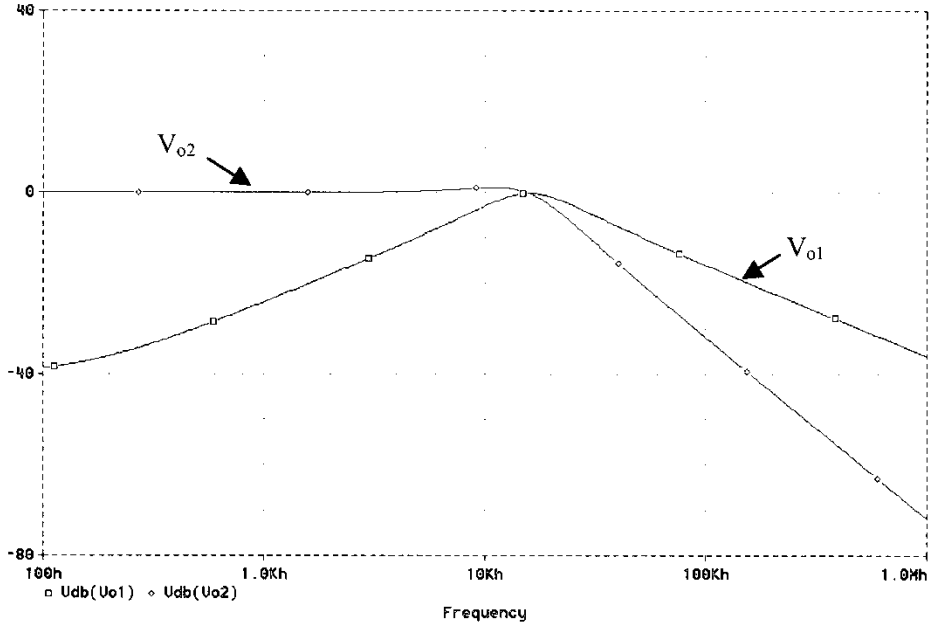

FIGURE 2 Simulation results of the bandpass and lowpass filters in Figure 1.

4 CONCLUSION

In this paper, a new voltage-mode universal biquadratic filter configuration with four inputs and two outputs has been presented. The new circuit offers several advantages, such as the

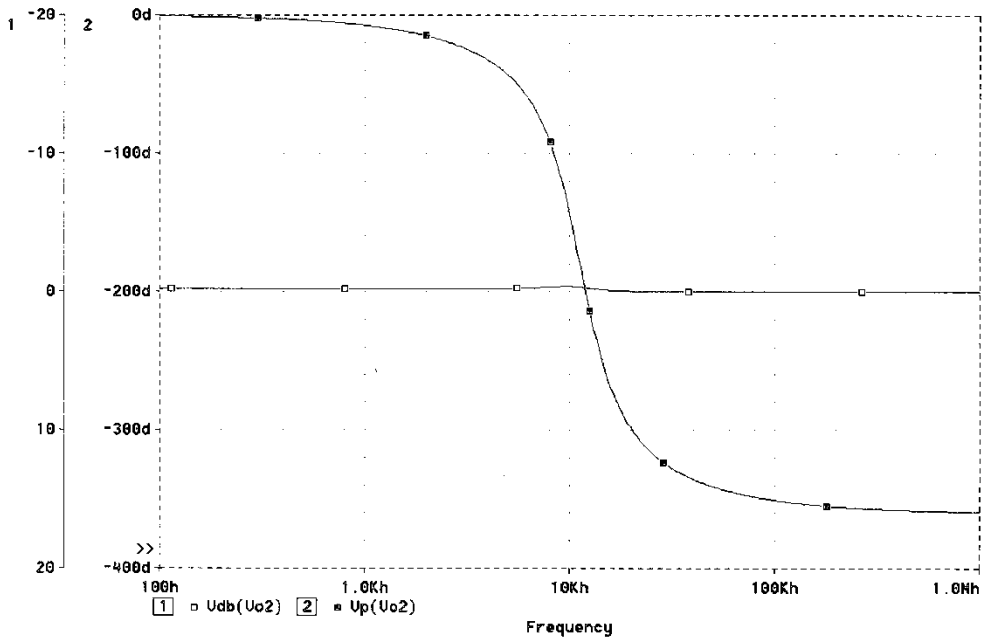

FIGURE 3 Simulation results of the allpass filter at V_{o2} in Figure 1. —□— gain response; —■— phase response.

use of only two OTAs and two capacitors; the versatility to synthesize highpass, bandpass, lowpass, notch and allpass responses from the same configuration; no need for a unity gain inverting component for allpass filter realizations; high input impedance and employing only grounded capacitors for bandpass and lowpass filter realizations in filter types (2) and (7); some derived filter types enjoy the availability of one more simultaneously output filter response (filter types (1), (2) and (4)) and good sensitivities performance.

References

- [1] Chang, C.-M. and Lee, M.-S. (1995). Comment: Universal voltage-mode filter with three inputs and one output using three current conveyors and one voltage follower. *Electronics Letters*, **31**, 353.
- [2] Horng, J.-W., Tsai, C.-C. and Lee, M.-H. (1996). Novel universal voltage-mode biquad filter with three inputs and one output using only two current conveyors. *International Journal of Electronics*, **80**, 543–546.
- [3] Horng, J.-W., Lee, M.-H., Cheng, H.-C. and Chang, C.-W. (1997). New CCII-based voltage-mode universal biquadratic filter. *International Journal of Electronics*, **82**, 151–155.
- [4] Chang, C.-M. and Tu, S.-H. (1999). Universal voltage-mode filter with four inputs and one output using two CCII + s. *International Journal of Electronics*, **86**, 305–309.
- [5] Horng, J.-W., Lee, M.-H. and Hou, C.-L. (1995). Universal active filter using four OTAs and one CCII. *International Journal of Electronics*, **78**, 903–906.
- [6] Nawrocki, R. and Klein, U. (1986). New OTA-capacitor realization of a universal biquad. *Electronics Letters*, **22**, 50–51.
- [7] Khan, I. A., Ahmed, M. T. and Minhaj, N. (1992). A simple realization scheme for OTA-C universal biquadratic filter. *International Journal of Electronics*, **72**, 419–429.
- [8] Sun, Y. and Fidler, J. K. (1993). Novel OTA-C realizations of biquadratic transfer functions. *International Journal of Electronics*, **75**, 333–340.
- [9] Wu, J. and Xie, C.-Y. (1993). New multifunction active filter using OTAs. *International Journal of Electronics*, **74**, 235–239.
- [10] Al-Ali, A. K., Abuelma'atti, M. T. and Tiwana, R. A. (1994). Programmable OTA-based multifunction active filter. *Active and Passive Electronic Components*, **17**, 21–27.
- [11] Sun, Y. and Fidler, J. K. (1996). Design of current-mode multiple output OTA and capacitor filters. *International Journal of Electronics*, **81**, 95–99.
- [12] Tsukutani, T., Ishida, M., Tsuiki, S. and Fukui, Y. (1996). Versatile current-mode biquad filter using multiple current output OTAs. *International Journal of Electronics*, **80**, 533–541.
- [13] Horng, J.-W., Weng, R.-M., Lee, M.-H. and Chang, C.-W. (1997). Universal active current filter using two multiple current output OTAs and one CCIII. *International Journal of Electronics*, **82**, 241–247.
- [14] Chang, C.-M. (1999). New multifunction OTA-C biquads. *IEEE Transactions on Circuits and Systems-II: Analog and Digital Signal Processing*, **46**, 820–824.



Hindawi

Submit your manuscripts at
<http://www.hindawi.com>

