
Understanding multistage experiments

Chumpol Yuangyai*

Department of Industrial Engineering,
King Mongkut's Institute of Technology,
Ladkrabang, Bangkok 10520, Thailand
E-mail: chumpol.yuangyai@gmail.com

*Corresponding author

Dennis K.J. Lin

Department of Statistics,
The Pennsylvania State University,
University Park, PA 16802, USA
E-mail: DKL5@psu.edu

Abstract: Current advanced manufacturing processes are composed of multiple complex stages which prohibit experimenters from conveniently employing traditional statistical experimental designs due to restrictions on randomisation. In this paper, we demonstrate, and summarise how split plot design and its variants have been used for multistage experimentation, and present several multistage experiment scenarios with comments for practitioners and researchers.

Keywords: process configuration; robust parameter design; RPD; split block; split plot.

Reference to this paper should be made as follows: Yuangyai, C. and Lin, D.K.J. (2013) 'Understanding multistage experiments', *Int. J. Experimental Design and Process Optimisation*, Vol. 3, No. 4, pp.384–409.

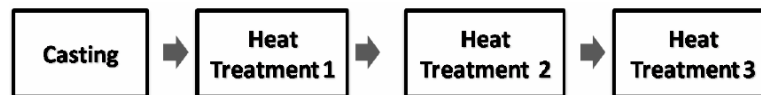
Biographical notes: Chumpol Yuangyai is currently an Assistant Professor at Department of Industrial Engineering, King Mongkut's Institute of Technology Ladkrabang (KMITL). He earned his PhD in Industrial Engineering and Operations Research from Pennsylvania State University in 2009, MEng in Industrial Engineering from Asian Institute of Technology in 2000, and BEng in Mechanical Engineering from Prince of Songkhla University in 1995. In addition to his academic career, he had been working in industry for a decade. His current research interests are in the area of statistical experimental designs, statistical process control, quality engineering, productivity improvement using simulation and operations research tools.

Dennis K.J. Lin is currently a University Distinguished Professor of Statistics and Supply Chain Management at Penn State University, as well as an Honorary Chair Professor at Fudan University. His research interests are quality engineering, industrial statistics, data mining and response surface. He has published near 200 professional (SCI/SSCI) papers in a wide variety of journals, and serves or served as associate editor for (more than ten) various top journals. He is an elected fellow of ASA, IMS, ASQ, an elected member of ISI, a lifetime member of ICOSA, and a fellow of RSS.

1 Introduction

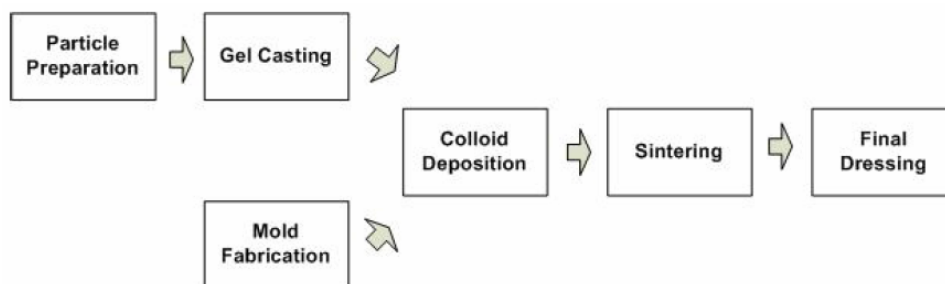
Advanced manufacturing processes, such as new material development (Freibert et al., 2002), nanomanufacturing (Yuanyai and Nembhard, 2009), and pharmaceutical manufacturing (Peterson et al., 2009) have become very complex. Typically, these processes consist of multiple stages. We first present two examples here. The first process is the development of a new alloy by a group of researchers at Los Alamos National Laboratory (Freibert et al., 2002). They developed a process (shown in Figure 1) for synthesising a plutonium alloy with a high decay rate. Their process consists of four stages: melting, heat treatment 1, heat treatment 2, and heat treatment 3. The process begins with melting the material, which is poured into a cast once it reaches its melting point. Then it is heated three separate times to obtain the desired material properties.

Figure 1 The synthesis process of a plutonium alloy



The second process is a nanomanufacturing process developed by a group of researchers at Penn State (Antolino et al., 2009a, 2009b). The process is called the lost mould rapid infiltration forming (LMRIF) process. It is comprised of six sub-processes: particle preparation, mould fabrication, monomer addition, colloid deposition, sintering and final dressing. The process flow is displayed in Figure 2. The process begins by preparing a nano-scale particle using an attrition milling chamber. The particle is then mixed up with a monomer and cross-linking agent to form gel properties, making it ready to fill the mould using a nano-scale lithography process. Once the moulds are filled, they are kept in a nitrogen environment and are then put in an ethyl alcohol bath to ease the drying process and prevent cracks. The moulds are then placed in furnaces to sinter the fabricated devices, after which the devices are removed and dressed.

Figure 2 The LMRIF process



These two processes are complicated and consist of several sub-processes or stages. It is difficult to improve product and process performance because experimenters face the

inability to completely follow the randomisation principle by randomly assigning the treatment combinations to experimental units and resetting each factor level. It is almost impossible to reset all factors because some factors (especially those in the first few stages) are hard to reset or change because of resource constraints. Labour, raw materials, and energy are all used to set up each experimental run.

For instance, assume that experimenters would like to study five factors, each with two levels over six stages. Based on full factorial design, they would have to prepare 32 settings for each stage, or $32 \times 6 = 192$ total settings. It would be almost impossible to randomly assign those 192 settings to experimental units. Furthermore, once experiments are complete, experimenters tend to analyse the results as if the data were taken from completely randomised designs, allowing the results to be misinterpreted and ultimately slowing down the development process.

These situations are not uncommon and they usually happen in industry where process improvement or new product development is involved. To deal with these situations where restrictions on randomisation exist, researchers have been focusing on using split plot design and its variants in situations where there are only two stages in a process, such as the work done by Box and Jones (1992), Huang et al. (1998), Bingham and Sitter (1999, 2001, 2003), Ju and Lucas (2002), Kowalski (2002), Kowalski et al. (2002), Goos (2002), Goos and Vandebroek (2001, 2004), Goos and Donev (2007), Vivacqua and Bisgaard (2004, 2009) and McLeod and Brewster (2004, 2006). Recent reviews for split plot design and its variants are found in Jones and Nachtsheim (2009) and Arnouts et al. (2009). However, relatively few works have considered experiments with three-or-more stages, with the exception of Mee and Bates (1998), Butler (2004), Paniagua-Quinones and Box (2008), Bingham et al. (2008) and Yuangyai et al. (2009).

For a long time, multistage experimentation has received little attention in industry experimentation, as most experimental design textbooks and research articles have focused on cases of completely randomised design or completely randomised design in block. Although split plot design has existed for decades, it has been adopted more by agriculture than industry. In this paper, we present a comprehensive review of articles that consider experiments with multiple processes both in design construction and statistical analysis. We also suggest several scenarios for further investigation.

First, we will discuss the uniqueness of the multistage experiment, followed by a review of the existing research on two-stage, three-stage, and four-or-more-stage experimentation. Several scenarios for multiple process environments will then be presented, with a discussion on future research opportunities and final remarks at the end.

2 Uniqueness of multistage experiments

To illustrate the uniqueness of multistage experiments, consider only two sub-processes of LMRIF: particle preparation and immersion, as shown in Figure 3. We assume that in the preparation process there are two factors of interest [percent of binder volume (x_1) and solid volume (x_2)] and that each factor has two levels (– and +). In the colloid deposition process, there is one factor of interest [type of immersing chemical (x_3)] and this factor has two levels. The response (y) is the process yield.

Figure 3 Two-stage process

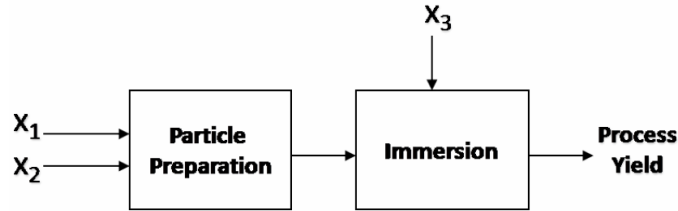
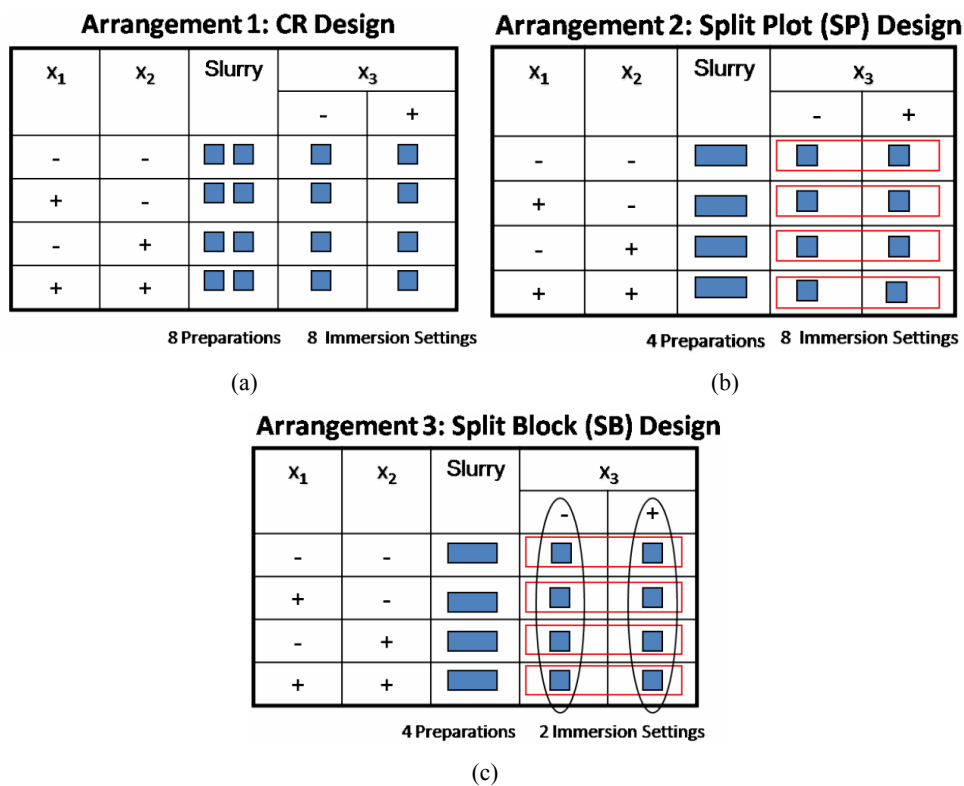


Figure 4 Three possible arrangements for two-stage experiments (a), (b) and (c), (a) CR design (b) split plot design (c) split block design (see online version for colours)



To conduct this experiment, three possible arrangements can be used. In the first arrangement, eight samples are prepared at different times, and each sample is placed into the immersion bath at different times [see Figure 4(a)]. In the second arrangement, only four sample preparations are required. Each of the samples is split into two sub-samples. Then each sub-sample is placed into the immersion bath at a different time. Therefore, there are four sample preparations and eight immersion settings [see Figure 4(b)]. In the third arrangement, only four samples are prepared (similar to the second arrangement), then each is split into two sub-samples, similar to those in the split plot design. However, these sub-samples are then regrouped and placed into the bath together at either the low level or the high level. This reduces the immersion settings from eight to only two [see Figure 4(c)]. Experimenters tend to use the third arrangement because the number of

settings in each stage is minimised as in Table 1. Once the experiments are done based on these three arrangements, the data is collected as in Table 2. Because traditional statistical design is heavily focused on complete randomisation or complete randomisation in block, the analysis is usually done as if the experimental data were collected from the first arrangement as in Figure 4(a). Unfortunately, this approach may lead to misinterpretation as discussed by several authors (e.g., Letsinger et al., 1996; Bisgaard, 2000; Yuangyai et al., 2009).

Table 1 Number of settings for each design

Arrangement	Number of settings in		Number of runs
	Particle preparation	Immersion	
1 [Figure 4(a)]	8	8	8
2 [Figure 4(b)]	4	8	8
3 [Figure 4(c)]	4	2	8

Table 2 Factors of interest

No.	Factor			% yield
	x_1	x_2	x_3	
1	-1	-1	-1	y_1
2	-1	-1	+1	y_2
3	-1	+1	-1	y_3
4	-1	+1	+1	y_4
5	+1	-1	-1	y_5
6	+1	-1	+1	y_6
7	+1	+1	-1	y_7
8	+1	+1	+1	y_8

The second and third arrangements can be referred to as split plot and split block structure, respectively. (The split block structure is also called strip block or strip plot.) The main advantage of a split plot or split block arrangement is a reduction in the number of settings required in each stage. However, the disadvantage is that the analysis becomes more complex due to multiple error terms because of the restrictions on randomisation.

From the previous example, it is clear that complex multistage manufacturing processes make it difficult to use a completely randomised design. Why is the randomisation principle important? Randomisation allows for the detection of all sources of variation affecting the final outcome except those due to the treatment itself. Randomisation tends to reduce the confounding of uncontrolled factors and controlled factors. It is very important in experimental analysis because it is required in order to have a valid estimation of random error. For more details about the randomisation principle, see Box et al. (2005) and Hinkelmann and Kempthorne (2008).

The uniqueness of multistage experimentation does not allow for the use of the naïve approach (which is based on the randomisation principle) because the approach treats stages independently. In multistage experimentation, the experimental units depend upon the previous stages, and the treatment combinations are not randomly assigned to those experimental units. Multistage experimenters use the split plot approach to reduce the

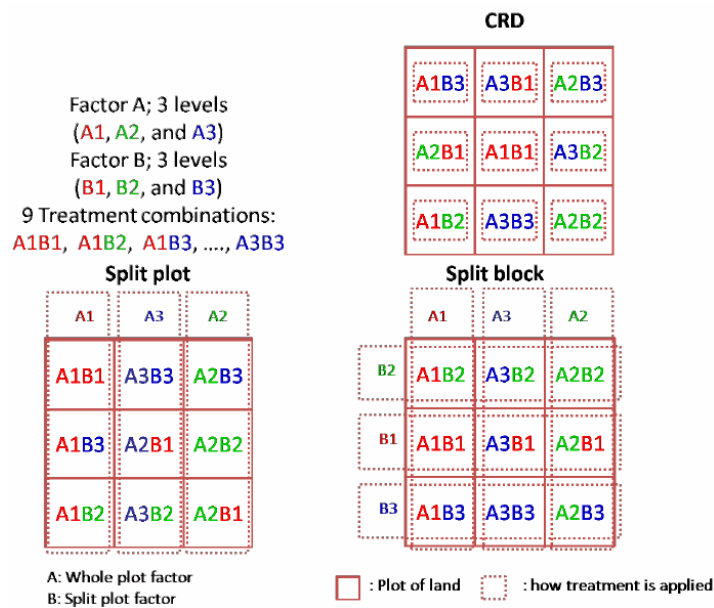
cost of experimentation in exchange for losing some degrees of freedom when estimating error terms.

As advanced process development becomes more complicated (i.e., the process consists of more than two stages), the three arrangements described earlier may not appropriately address experimental structures. Not only does the number of setting preparations in each stage increase, but there are also many design choices to be considered. What is the appropriate design? How can designs be recognised when there are processes in series or in parallel? How and when should multistage designs be used? The answers to all of these questions are important considerations when modifying existing designs in response to the uniqueness of multistage experiments. Sometimes, a completely new methodology for design and analysis is required. Unfortunately, few research studies focus on complex processes, and there is no generalised solution for multistage statistical design and analysis. In the next section, we summarise the existing methodology for multistage experiments.

3 Existing methodology

In many manufacturing settings, multistage processes exist when it is expensive or difficult to change the levels of some of the factors, or there are physical restrictions on the process. In the past, researchers have focused their efforts on effectively employing split plot designs (and their variants) for two-stage processes. The term ‘split plot’ is originated from agricultural experiments in which large plots of land are split into subplots. The original work on split plots was completed by Fisher (1925), with developments offered by Yates (1937), Kempthorne (1952), Box and Jones (1992), and many others.

Figure 5 Split plot and split block design in agricultural experiments (see online version for colours)



Experimentation on a plot of land is shown in Figure 5. Suppose that we are considering two factors (*A* and *B*) and each has three levels, requiring nine treatments in total. If a completely randomised design is used, all nine treatments are randomly assigned to nine subplots of land. If the split plot arrangement is used, factor *A* is used as a whole plot factor, and its three levels are randomly assigned on three plots of land with levels of factor *B* randomly assigned within each subplot. In split block, three levels of both factor *A* (*A*₁, *A*₂, and *A*₃) and *B* (*B*₁, *B*₂, and *B*₃) are randomly assigned across the land.

The split plot design is one that has a two-factor factorial arrangement of a whole plot factor and a subplot factor and the whole plot experimental units are split into subplot units. This is to be distinguished from the split block design, where the whole plot unit is split and then regrouped before applying the subplot treatments.

To extend the idea of split plot and split block to a two-stage experiment, the whole plot factors become the Stage 1 factors, and the subplot factors become Stage 2 factors. Additionally, for the split block design, the column factors and the row factors become either Stage 1 or Stage 2 factors depending on which ones come first in the process flow.

To our best knowledge, Table 3 provides a summary of research related to multistage experimental design in industry, the development of two-, three-, and four-stage experiments are presented in separate subsections.

Table 3 Research on multistage experimentation in industry

<i>Paper</i>	<i>No. of stages</i>			<i>ART</i>	<i>Design types</i>							
	2	3	≥ 4		<i>Fu</i> <i>ll</i>	<i>2L</i> <i>F</i>	<i>3L</i> <i>F</i>	<i>MI</i> <i>X</i>	<i>RS</i> <i>M</i>	<i>OP</i> <i>T</i>	<i>RP</i> <i>D</i>	<i>OTH</i>
Box and Jones (1992)	✓			SP, SB	✓							✓
Letsinger et al. (1996)	✓			SP					✓	✓		
Huang et al. (1998)	✓			SP		✓						
Bingham and Sitter (1999)	✓			SP		✓	✓					
Bisgaard (2000)	✓			SP		✓						
Bingham and Sitter (2001)	✓			SP		✓						
Goos and Vandebroek (2001)	✓			SP						✓		
Trinca and Gilmour (2001)	✓			SP					✓			
Ju and Lucas (2002)	✓			SP	✓							
Kowalski (2002)	✓			SP			✓					✓
Kowalski et al. (2002)	✓			SP				✓	✓			
Bingham and Sitter (2003)	✓			SP		✓						✓
Bingham et al. (2004)	✓			SP		✓						
Goos and Vandebroek (2004)	✓			SP						✓		
McLeod and Brewster (2004)	✓			SP		✓						
Vining et al. (2005)	✓			SP					✓			
McLeod and Brewster (2006)	✓			SP		✓						✓
Parker et al. (2006)	✓			SP					✓			

Notes: ART: design arrangement; Full: full factorial design; 2LF: two-level fractional factorial design; 3LF: three-level fractional factorial design; MIX: mixture design; RSM: response surface design; OPT: optimal design; RPD: robust parameter design; OTH: other design, ¹: Latin square fraction design, and ²: linear graph.

Table 3 Research on multistage experimentation in industry (continued)

Paper	No. of stages			ART	Design types								
	2	3	≥ 4		Full	2L	3L	MI	RS	OP	RP	OTH	
Parker et al. (2007)	✓			SP					✓				
Goos and Donev (2007)	✓			SP				✓	✓	✓			
Cheng and Tsai (2009)	✓			SP	✓	✓							
Miller (1997)	✓			SB		✓						✓ ¹	
Gilmour and Trinca (2003)	✓			SP					✓				
Vivacqua and Bisgaard (2004)	✓			SB		✓							
Vivacqua and Bisgaard (2009)	✓			SB		✓							
Arnouts et al. (2009)	✓			SB						✓			
Acharya and Nembhard (2008)	✓			SP		✓							
Jones and Goos (2009)	✓			SP						✓			
Paniagua-Quinones and Box (2008)	✓			SB		✓							
Yuangyai et al. (2009)	✓			SP and SB		✓							
Mee and Bates (1998)	✓	✓	✓	SB		✓						✓ ²	
Butler (2004)	✓	✓	✓	SB		✓							
Bingham et al. (2008)	✓	✓	✓	SP		✓							
Yuangyai and Nembhard (2013)	✓	✓		SP and SB		✓							

Notes: ART: design arrangement; Full: full factorial design; 2LF: two-level fractional factorial design; 3LF: three-level fractional factorial design; MIX: mixture design; RSM: response surface design; OPT: optimal design; RPD: robust parameter design; OTH: other design, ¹: Latin square fraction design, and ²: linear graph.

3.1 Two-stage experimentation

We present the following examples to illustrate the nature of two-stage experiments. These two examples follow the split plot and split block structure, respectively:

- 1 Bingham and Sitter (1999) described a wood product experiment using split plot structure. The experiment involves a two-stage process: the mixing stage and the processing stage. The objective is to study the effects of eight factors, with two levels each. These factors are divided into two groups: five factors in Stage 1 and three factors in Stage 2. Due to process restrictions, the experiment was conducted by first randomly preparing batches with different treatment combinations of the five factors in Stage 1. Then each batch was divided into sub-batches. Each sub-batch was then applied a treatment combination of the three factors in Stage 2 to further facilitate the forming process.

- 2 Another experiment was conducted in split block structure and described by Vivacqua and Bisgaard (2004). A battery manufacturer conducted a battery cell experiment. Four factors in the assembly process (Stage 1) and two factors in the curing process (Stage 2) were investigated in order to improve the open circuit voltage for a certain type of battery. Due to budget limitations, the experimenters first randomly assembled battery cells and then simultaneously applied the same curing conditions to the assembled cells.

3.1.1 Design construction

In each stage, the structure of an experiment can be chosen from several traditional designs, including full factorial, fractional factorial, response surface, mixture, optimal, and robust parameter. How should a design be chosen? We recommend that experimenters consider whether the designs serve their experimental objectives. For example, if experimenters wish to study only a first-order model, the fractional factorial design may be appropriate, whereas response surface design may be suitable for first-order and second-order modelling. If experimenters have some prior knowledge about the existing process, optimal design may be used. Jones and Nachtsheim (2009) reviewed several cases where the split plot arrangement was used, and Arnouts et al. (2009) reviewed several using the split block arrangement. We summarise them as follows:

- *Full factorial design*: Box and Jones (1992) first discussed the full factorial design in split plot. The main advantage of the full factorial design is the ability to estimate all main effects and all interactions under the replicated condition. If an unreplicated design is conducted, some higher order interactions in the split plot factors and whole plot factors need to be pooled and used as error terms. In addition, Box and Jones (1992) further considered the situation where a split block arrangement is used and there are three sources of error involved.
- *Fractional factorial design*: To reduce the number of runs and the number of settings in each stage, Huang et al. (1998) and Bingham and Sitter (1999, 2001) proposed a design plan based on maximum resolution and minimum aberration. Another method was proposed by Bisgaard (2000) using split plot confounding. These proposals focused on only split plot structure. Vivacqua and Bisgaard (2004, 2009) proposed an optimal design based on split block structure and they also provided a catalogue design based only on minimum aberration criteria using a post-fractionation technique. In addition, Butler (2004) proposed a new method called 'grid representation' to determine a design catalogue based on split block structure.
- *Response surface design*: To optimise process or product performances, response surface methodology is used. This allows us to estimate the first- and second-order polynomial terms. Two available designs include central composite design and Box and Behnken design. Letsinger et al. (1996) first discussed the RSM in split plot arrangement. Other studies include the mixture experiment and the RSM by Kowalski (2002), Kowalski et al. (2002) and Vining et al. (2005).
- *Mixture design*: The mixture design is different from other types of design in which all factor levels are independent. In mixture design, it is assumed that relationships among factors exist. Suppose that in a chemical mixing experiment of

two chemicals, the experimenter would like to test how the quantity of each chemical affects the properties of the mixed chemical. In this case, we would use the previous design. However, if the experimenter wanted to study the effect of the chemical ratio of two substances such as 1:3 or 1:2, a mixture design would be used under the constraint that summation of the ratio must be equal to one. Examples of mixture design can be found in Kowalski (2002), Kowalski et al. (2002) and Goos and Donev (2007).

- *Optimal design*: The pioneering work on optimal design using split plot structure with D-optimality was done by Goos and his colleagues (Goos, 2002; Goos and Donev, 2007; Goos and Vandebroek, 2001, 2004). Recall that this type of design is used when an experimenter has some information about the process and it can be specified by a response model. In addition, it is helpful when there are restrictions on the physical design region. Additional discussion on split block structure with D-optimality can be found in Trinca and Gilmour (2001), Gilmour and Trinca (2003) and Gilmour (2006).
- *Robust parameter design (RPD)*: Oftentimes, new products are successfully produced in laboratory settings, but when production is transitioned to a full-scale manufacturing process the results are reversed due to fluctuations in uncontrollable factors such as process parameters, raw materials, and customer usage. To solve these problems, Taguchi (1987) introduced the concept of RPD to the quality engineering community. RPD is a methodological technique to deal with two types of factors: controllable and uncontrollable (noise). The objective of RPD is to determine which controllable factor levels provide the optimal output performance with minimal output variability due to noise factors. [For more details, see Shoemaker et al. (1991).] For example, in the particle preparation stages of the lost mold rapid infiltration process, there are five factors of interest: solid loading, gel, binder, milling time, and milling chamber temperature. In laboratory settings, all five factors can be controlled; however, when these stages are scaled for manufacturing, temperature becomes difficult to control due to changes in the weather. Little research focuses on RPD with restrictions on randomisation. Recent developments are discussed by Bingham and Sitter (2003) and McLeod and Brewster (2006) who study how to use split plot design for RPD purposes. Therefore, it is necessary to develop a multistage experimentation design with the RPD concept in mind for situations where restrictions on randomisation exist.

3.1.2 Analysis

Another important issue in split plot and split block arrangements is analysis. Split plot has two error terms and split block has three, which differs greatly from completely randomised design where there is only one error term used.

Two-stage experiment with split plot structure

For a simple case where balanced-replicated fractional and factorial design is used, the ANOVA model may be employed for describing the observational data from an experiment. In order to construct a linear model, it is necessary to understand the linear

model for both a split plot and a split block design. Assume that there are a levels of a Stage 1 factor, b levels of a Stage 2 factor, and n replicates.

Based on the randomisation principle, a linear model for a two-stage design is

$$y_{hij} = \mu + \rho_h + \alpha_i + \epsilon_{hi}^{s_1} + \beta_j + \alpha\beta_{ij} + \epsilon_{hij}^{s_2} \tag{1}$$

where y_{hij} is the h_{ij}^{th} response of the experiment for $h = 1 \dots n, i = 1 \dots a, j = 1 \dots b$, μ is the general overall mean effect, ρ^h is the replicate effect $\sim \text{iid } N(0, \sigma_\rho^2)$, α_i is the effect of i^{th} whole plot factor, $\epsilon_{hi}^{s_1}$ is the h_i^{th} random error effect $\text{iid } N(0, \sigma_{s_1}^2)$, β_j is the effect of j^{th} level of subplot factor, $\alpha\beta_{ij}$ is the interaction effect of ij^{th} combination of Stage 1 and Stage 2 factors, and $\epsilon_{hij}^{s_2}$ is the h_{ij}^{th} random error effect $\sim \text{iid } N(0, \sigma_\epsilon^2)$. The $\rho_h, \epsilon_{hi}^{s_1}$, and $\epsilon_{hij}^{s_2}$ are assumed to be mutually independent.

In addition, if we cannot replicate the design, two probability plots can be used. One plot involves only effects of the Stage 1 factors and the other involves effects of Stage 2 factors and the interactions of Stage 1 and Stage 2 factors. However, for more complicated situations (e.g., unbalanced design), second-order polynomial analysis is required. The regression model in matrix form is given by

$$Y = X\beta + Z\gamma + \epsilon \tag{2}$$

where Y is the $n \times 1$ vector of responses, X is the $n \times p$ model matrix with settings of both Stage 1 factors and Stage 2 factors, β is the $p \times 1$ parameter vector of effects, Z is a $n \times a$ matrix with (i, j) elements, indicating that i^{th} is one when j^{th} run is assigned to the Stage 1 factor and zero, otherwise, γ is the $a \times 1$ vector of Stage 1 random effects. We also assume that

$$\begin{aligned} \epsilon &\sim N(0_n, \sigma^2 I_n), \\ \gamma &\sim N(0_a, \sigma_{s_1}^2 I_a) \end{aligned}$$

and

$$\text{cov}(\epsilon, \gamma) = \mathbf{0}_{a \times n},$$

where I_n denotes and $n \times n$ identity matrix. Under this assumption, the variance-covariance matrix can be expressed as

$$V = \sigma^2 I_n + \sigma_{s_1}^2 ZZ' \tag{3}$$

and $V = \text{diag}[V_1, V_2, \dots, V_n]$. The maximum likelihood estimator of β is

$$\hat{\beta} = (X'V^{-1}X)^{-1} X'V^{-1}Y \tag{4}$$

with variance-covariance matrix

$$\text{Cov}(\hat{\beta}) = (X'V^{-1}X)^{-1} \tag{5}$$

Two-stage experiment with split block structure

As for split block structure, the analysis is similar to split plot structure except that there is an additional error term. A linear model for a split block design is

$$y_{hij} = \mu + \rho_h + \alpha_i + \epsilon_{hi}^{s_1} + \beta_j + \epsilon_{hj}^{s_2} + \alpha\beta_{ij} + \epsilon_{hij}^{s_1 \text{ and } s_2} \quad (6)$$

where y_{hij} is the h_{ij}^{th} response of the experiment for $h = 1 \dots n, i = 1 \dots a, j = 1 \dots b, \mu$ is the general overall mean effect, ρ_h is the replicate effect $\sim \text{iid } N(0, \sigma_\rho^2)$, α_i is the effect of i^{th} whole plot factor, $\epsilon_{hi}^{s_1}$ is the replicate effect $\sim \text{iid } N(0, \sigma_\rho^2)$, β_j is the effect of j^{th} level of subplot factor, $\epsilon_{hj}^{s_2}$ is the hj^{th} random error effect $\text{iid } N(0, \sigma_\delta^2)$, $\alpha\beta_{ij}$ is the interaction effect of ij^{th} combination of Stage 1 and Stage 2 factors, and $\epsilon_{hij}^{s_1 \text{ and } s_2}$ is the hij^{th} random error effect $\sim \text{iid } N(0, \sigma_\epsilon^2)$. The $\rho_h, \epsilon_{hi}^{s_1}, \epsilon_{hj}^{s_2}$ and $\epsilon_{hij}^{s_1 \text{ and } s_2}$ are mutually independent.

And for the generalised analysis, we can express the model in matrix form as

$$Y = X\beta + Z_1\gamma_1 + Z_2\gamma_2 + \epsilon \quad (7)$$

where Y is the $n \times 1$ vectors of responses, X is the $n \times p$ model matrix of Stage 1 with Stage 2 setting, Z_1 is a $n \times a$ matrix with (i, j) with i^{th} where i^{th} is one when j^{th} run is assigned to the i^{th} Stage 1 factors and zero, otherwise. Z_2 is a $n \times b$ matrix with (i, j) where i^{th} is one when j^{th} run is assigned to the i^{th} Stage 2 factors and zero, otherwise. $\epsilon \sim N(0_n, \sigma^2 I_n), \gamma_1 \sim N(0_a, \sigma_{s_1}^2 I_a),$ and $(\sigma^2 I_n), \gamma_2 \sim N(0_b, \sigma_{s_2}^2 I_b),$ $Cov(\gamma_1, \epsilon) = 0_{a \times n},$ $Cov(\gamma_2, \epsilon) = 0_{b \times n},$ and $Cov(\gamma_1, \gamma_2) = 0_{a \times b},$ where I_n denotes and $n \times n$ identity matrix. The variance-covariance matrix can be expressed as

$$V = \sigma^2 I_n + \sigma_{s_1}^2 Z_1 Z_1' + \sigma_{s_2}^2 Z_2 Z_2' \quad (8)$$

The β vector can be estimated using the generalised least squares method and it can be used equation (4) and equation (5). This is similar to those of split plot structure but with a different V matrix involved.

Another advantage of the split plot design is the design efficiency as discussed by Box and Jones (1992). In split plot structure, there are two error terms e_{s_1} , and e_{s_2} (s_1 is Stage 1 factor, s_2 is Stage 2 factor). Relative efficiency to completely randomised (CR) design is ($E =$ expected mean square error): $E_{s_2} = \sigma_{s_2}^2 < \sigma_{s_2}^2 + n\sigma_{s_1}^2 = E_{s_1}$ and so $E_{s_2} < E_{CR} < E_{s_1}$. Relative efficiency to a randomised block (RB) design is $E_{s_2} = \sigma_{s_2}^2 < \sigma_{s_2}^2 + n\sigma_{s_1}^2 = E_{s_1}$ and so $E_{s_2} < E_{RB} < E_{s_1}$. In split block structure, there are three error terms $E_{s_1}, E_{s_2}, E_{s_1 \text{ and } s_2}$. Relative efficiency to split plot design is $E_{r \times c} = \sigma^2 + m\sigma_{s_1}^2 = E_{s_1}$, thus, $E_{s_1 \text{ and } s_2} < E_{s_2} < E_c, E_{r \times c} < E_{s_2} < E_r$. Similar results are illustrated by Ju and Lucas (2002), in which the hard to change factor refers to Stage 1 factor and easy to change factor refers to Stage 2 factor.

3.1.3 General observations

As shown in Table 3, the majority of research heavily focuses on using split plot design for two-stage experiments as opposed to the split block arrangement. Much research

focus on fractional factorial design, relatively few focus on RSM and optimal design, and no studies focus on super-saturated design. In addition, criteria used in fractional factorial design for both structures include maximum resolution (Acharya and Nembhard, 2008; Vivacqua and Bisgaard, 2009), minimum aberration (Bingham and Sitter, 1999, 2001, 2003; Yuangyai et al., 2009), maximum number of clear two-factor interaction (Kulahci et al., 2006), and model robustness criterion of information capacity (Cheng and Tsai, 2009). RPD is a common area that can be extended after split plots and split arrangements are well defined. This indicates that RPD can also be extended for multistage experiments. In fact, designs were extended from the work of both Bingham and Sitter (2003) and McLeod and Brewster (2006).

3.2 *Three-stage experimentation*

To demonstrate three-stage experiments, we offer the following examples for illustration:

- 1 Acharya and Nembhard (2008) considered an experiment on thin film nanofabrication in wafer development. The process consists of three main stages: self-assembled monolayer, anchoring catalyst, and poly brush synthesis. In Stage 1, monolayers are developed on substrate, then they are divided into subgroups and each subgroup of substrates is immersed with a catalyst at a different time. Next, all substrates are rinsed and dried. Then each group is divided into another subgroup and they are placed in a closed environment in order to synthesise the thin film on the substrates.
- 2 Paniagua-Quinones and Box (2008) presented a three-stage experiment for the improvement of air batteries. This includes three main processes: the coating process (two factors), the curing process (two factors), and the tumbling process (three factors). The objective is to minimise an inference force. The experiment begins by preparing grommets with a treatment combination of Stage 1 factors, then each lot is divided and regrouped for a treatment combination of Stage 2 factors. In Stage 3, each group is divided and regrouped again for the treatment combination of Stage 3 factors. This structure is similar to only split block structures (also referred to as a strip strip block design).
- 3 Yuangyai et al. (2009) discuss the combination of split plot and split block structure for three-stage experiments involving five factors which affect the yield of a nanofabrication process. The process involves three stages: particle milling (three factors), surface coating (one factor), and immersion (one factor). The experiment begins by milling different types of mixtures based on Stage 1 treatment combinations, then each mixture is divided into portions and poured into a group of moulds. Each group of moulds is then divided into two groups, regrouped and placed into a furnace.

3.2.1 *Design construction*

Design construction for three-stage designs is similar to two-stage designs. Any type of design can be used. However, as Table 3 indicates, most works involve only fractional factorial designs (Acharya and Nembhard 2008; Paniagua-Quinones and Box 2008; Yuangyai et al. 2009) and optimal designs (Jones and Goos 2009).

3.2.2 Analysis

The data analysis for three-stage designs becomes more complicated because there are several error terms involved. In order to determine how many error terms exist, the reader should consult Hinkelmann and Kempthorne (2008) and Federer and King (2007). For split plot structure, there are only three error terms involved, while for split block structure, there are seven error terms. If Stage 1 and Stage 2 are arranged in split plot and Stage 2 and Stage 3 are arranged in split block, there are six error terms.

In the case of a balanced-replicated full and fractional factorial design, the ANOVA model is used. Assume that there are a levels of Stage 1 factors, b levels of Stage 2 factors, c levels of Stage 3 factors and n replicates. The ANOVA models can be shown in different structures as follows:

Three-stage experiment with only split plot structure

The following model is called for in experiments where there are only split plot arrangements:

$$y_{ghij} = \mu + \rho_g + \alpha_h + \varepsilon_{gh}^{s_1} + \beta_i + \alpha\beta_{hi} + \alpha\varepsilon_{ghi}^{s_2} + \gamma_j + \alpha\gamma_{hj} + \beta\gamma_{ij} + \alpha\beta\gamma_{hij} + \varepsilon_{ghij}^{s_3} \quad (9)$$

where y_{ghij} is the $ghij$ th response of the experiment for $g = 1 \dots n$, $h = 1 \dots a$, $i = 1 \dots b$, $j = 1 \dots c$, μ is the general overall mean effect, ρ_g is the g th replicate effect $\sim \text{iid } N(0, \sigma_\rho^2)$, α_h is the effect of h th level of Stage 1 factor, $\varepsilon_{gh}^{s_1}$ is the gh th random error effect $\sim \text{iid } N(0, \sigma_{\varepsilon^{s_1}}^2)$, β_i is the effect of i th level of Stage 2 factor, $\varepsilon_{ghi}^{s_2}$ is the ghi th random error effect $\sim \text{iid } N(0, \sigma_{\varepsilon^{s_2}}^2)$, $\alpha\beta_{hi}$ is the interaction effect of hi th combination of Stage 1 and 2 factors, γ_j is the effect of j th level of Stage 3 factor, $\beta\gamma_{ij}$ is the interaction effect of ij th combination of Stage 1 and Stage 2 factors, $\alpha\beta\gamma_{hij}$ is the interaction effect of hij th combination of Stage 1 and Stage 2 factors, and $\varepsilon_{ghij}^{s_3}$ is the $ghij$ th random error effect $\sim \text{iid } N(0, \sigma_{\varepsilon^{s_3}}^2)$. The ρ_h , $\varepsilon_{gh}^{s_1}$, $\varepsilon_{ghi}^{s_2}$, and $\varepsilon_{ghij}^{s_3}$, are mutually independent.

Three-stage experiment with only split block structure

The following model is used for experiments where there are only split block arrangements:

$$y_{ghij} = \mu + \rho_g + \alpha_h + \varepsilon_{gh}^{s_1} + \beta_i + \varepsilon_{gi}^{s_2} + \alpha\beta_{hi} + \varepsilon_{ghi}^{s_1 \text{ and } s_2} + \gamma_j + \varepsilon_{gj}^{s_3} + \alpha\gamma_{hi} + \varepsilon_{ghj}^{s_1 \text{ and } s_3} + \beta\gamma_{ij} + \varepsilon_{gij}^{s_2 \text{ and } s_3} + \alpha\beta\gamma_{hij} + \varepsilon_{ghij}^{s_1 \text{ and } s_2 \text{ and } s_3} \quad (10)$$

where y_{ghij} is the $ghij$ th response of the experiment for $g = 1 \dots n$, $h = 1 \dots a$, $i = 1 \dots b$, $j = 1 \dots c$, μ is the general overall mean effect, ρ_g is the g th replicate effect $\sim \text{iid } N(0, \sigma_\rho^2)$, α_h is the effect of h th level of Stage 1 factor, $\varepsilon_{gh}^{s_1}$ is the gh th random error effect $\sim \text{iid } N(0, \sigma_{\varepsilon^{s_1}}^2)$, β_i is the effect of i th level of Stage 2 factor, $\varepsilon_{gi}^{s_2}$ is the gi th random error effect $\sim \text{iid } N(0, \sigma_{\varepsilon^{s_2}}^2)$, $\alpha\beta_{hi}$ is the interaction effect of hi th combination of Stage 1 and Stage 2 factors, $\varepsilon_{ghi}^{s_1 \text{ and } s_2}$ is the ghi th random error effect $\sim \text{iid } N(0, \sigma_{\varepsilon^{s_1 \text{ and } s_2}}^2)$, γ_j is the effect of j th

level of Stage 3 factor, $\varepsilon_{gj}^{s_3}$ is the gj^{th} random error effect $\sim \text{iid } N(0, \sigma_{\varepsilon^{s_3}}^2)$, $\beta\gamma_{hi}$ is the interaction effect of hi^{th} combination of Stage 1 and Stage 2 factors, $\varepsilon_{gij}^{s_2 \text{ and } s_3}$ is the gij^{th} random error effect $\sim \text{iid } N(0, \sigma_{\varepsilon^{s_2 \text{ and } s_3}}^2)$, $\alpha\beta\gamma_{hi}$ is the interaction effect of hi^{th} combination of Stage 1 and Stage 2 factors, $\varepsilon_{ghij}^{s_3}$ is the $ghij^{\text{th}}$ random error effect $\sim \text{iid } N(0, \sigma_{\varepsilon^{s_1 \text{ and } s_2 \text{ and } s_3}}^2)$, the ρ_h , $\varepsilon_{hi}^{s_1}$, $\varepsilon_{gi}^{s_2}$, $\varepsilon_{gj}^{s_3}$, $\varepsilon_{ghi}^{s_1 \text{ and } s_2}$, $\varepsilon_{ghij}^{s_2 \text{ and } s_3}$, and $\varepsilon_{ghij}^{s_1 \text{ and } s_2 \text{ and } s_3}$ are mutually independent.

Three-stage experiment with the combination of split plot and split block structure

The following model is used for experiment arrangements where there are split plot designs in Stage 1 and Stage 2 and split block designs in Stage 3.

$$y_{ghij} = \mu + \rho_g + \alpha_h + \varepsilon_{gh}^{s_1} + \beta_i + \alpha\beta_{hi} + \varepsilon_{ghi}^{s_1 \text{ and } s_2} + \gamma_j + \varepsilon_{gj}^{s_3} + \alpha\gamma_{hj} + \varepsilon_{ghj}^{s_1 \text{ and } s_3} + \beta\gamma_{ij} + \varepsilon_{gij}^{s_2 \text{ and } s_3} + \alpha\beta\gamma_{hij} + \varepsilon_{ghij}^{s_1 \text{ and } s_2 \text{ and } s_3} \tag{11}$$

where y_{ghij} is the $ghij^{\text{th}}$ response of the experiments for $g = 1 \dots n$, $h = 1 \dots a$, $i = 1 \dots b$, $j = 1 \dots c$, μ is the general overall mean effect, ρ_g is the g^{th} replicate effect $\sim \text{iid } N(0, \sigma_{\rho}^2)$, α_h is the effect of h^{th} level of Stage 1 factor, $\varepsilon_{gh}^{s_1}$ is the gh^{th} random error effect $\sim \text{iid } N(0, \sigma_{\varepsilon^{s_1}}^2)$, β_i is the effect of i^{th} level of Stage 2 factor, $\alpha\beta_{hi}$ is the interaction effect of hi^{th} combination of Stage 1 and Stage 2 factors, $\varepsilon_{ghi}^{s_1 \text{ and } s_2}$ is the ghi^{th} random error effect $\sim \text{iid } N(0, \sigma_{\varepsilon^{s_1 \text{ and } s_2}}^2)$, $\alpha\gamma_{hj}$ is the interaction effect of hj^{th} combination of Stage 1 and Stage 3 factors, $\varepsilon_{ghj}^{s_1 \text{ and } s_3}$ is the ghj^{th} random error effect $\sim \text{iid } N(0, \sigma_{\varepsilon^{s_1 \text{ and } s_3}}^2)$, γ_j is the effect of j^{th} level of Stage 3 factor, $\varepsilon_{gj}^{s_3}$ is the gj^{th} random error effect $\sim \text{iid } N(0, \sigma_{\varepsilon^{s_1 \text{ and } s_3}}^2)$, $\beta\gamma_{ij}$ is the interaction effect of hi^{th} combination of Stage 1 and Stage 2 factors, $\varepsilon_{gij}^{s_2 \text{ and } s_3}$ is the gij^{th} random error effect $\sim \text{iid } N(0, \sigma_{\varepsilon^{s_2 \text{ and } s_3}}^2)$, $\alpha\beta\gamma_{hij}$ is the interaction effect of hi^{th} combination of Stage 1 and Stage 2 factors, $\varepsilon_{ghij}^{s_3}$ is the $ghij^{\text{th}}$ random error effect $\sim \text{iid } N(0, \sigma_{\varepsilon^{s_3}}^2)$, the ρ_h , $\varepsilon_{hi}^{s_1}$, $\varepsilon_{gh}^{s_1 \text{ and } s_2}$, $\varepsilon_{gj}^{s_3}$, $\varepsilon_{ghj}^{s_1 \text{ and } s_3}$, $\varepsilon_{gij}^{s_2 \text{ and } s_3}$, and $\varepsilon_{ghij}^{s_3}$ are mutually independent.

3.2.3 General observations

The most common design used in this area is fractional factorial design, although optimal design is also discussed. However, there are no studies on RSM, saturated design or super saturated design. For fractional factorial design, maximum resolution and minimum aberration criteria are generally used. Unlike two-stage experiments, at the three-stage level, there is only a single type of design used for each stage. In addition, analysis issues are not well studied, especially when split plot and split block structures are combined. In addition, there are no studies on design efficiency.

3.3 Four-or-more stages

Four-or-more stage experiments can be extended from three-stage experiments, however, very few research studies focus on this area. When more stages are involved, complexity increases for both design and analysis.

For the fractional factorial design, Mee and Bates (1998) introduced the concept of the multistage experiment. They presented an experiment over nine stages but did not provide the design catalogue. Butler (2004) provided the optimal design catalogue for a four stage experiment based on split block structure. Bingham et al. (2008) provided a general algorithm for fractional factorial design.

Analysing these experiments is very complicated. It is easier to analyse the data based on split plot structure because the number of error terms are equal to number of stages. For the split block structure, the number of error terms are equal to $\binom{n}{1} + \binom{n}{2} + \dots + \binom{n}{n} = 2^n - 1$; where n is the number of stages. Whereas, for the combined structure, the number of error terms will be determined based on the structure we consider: the number will be between n and $2n - 1$. The design and analysis problem is not well defined and is difficult to generalise. Several design and analysis issues require further investigation, and will be discussed in a later section.

4 Multistage experimentation

Multistage experimentation is an extension of split plot design and its variants. It can be thought of as having a single whole plot and a subsequent series of subplots. The format of the series of subplots can be either split plot structure or split block structure based on the nature of the experiment.

4.1 Definition

A multistage experiment is an experiment that involves more than two stages. A stage can be defined by experimenters based on the nature of the process itself, a process location, or a group of operations in which treatment combinations among factors can be conveniently applied to experimental units in each stage. To illustrate the idea of multistage experimentation, we consider several scenarios based on:

- number of stages (two stages, three stages, four-or-more stages)
- process type (series or parallel)
- nature of experimentation (nested structure)
- ability to replicate the design
- blocking structure.

To display the different scenarios, Table 4 shows the descriptions that are used to explain the different process configurations as well as how experimental units are treated among stages. For example, Figure 6 displays a schematic diagram for a two-stage process where Stage 2 follows Stage 1, which is a series structure. Based on this process, Figure 7 could be an alternative. An experiment could be conducted using replication, with two replicates in Stage 2. In each replicate, the Stage 2 treatments would be applied at the same time to the experimental units.

Table 4 Representation of a multistage experiment (see online version for colours)


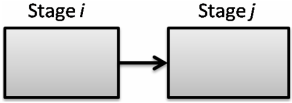

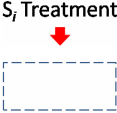

Representation	Description
	Indicates the Stage i .
	Indicates the process flow from Stage i to Stage j .
	Indicates the experimental unit in Stage i .
	Indicates that treatment combinations of Stage i factors are applied the experimental unit in that stage.
	Indicates that treatment combinations are applied at the same time.

Figure 6 A schematic diagram of a two-stage process

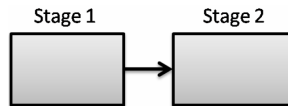
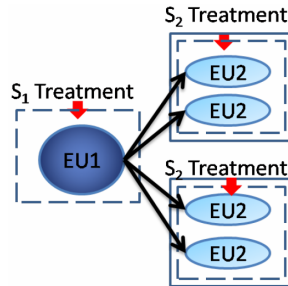


Figure 7 Experimental units for a two-stage process (see online version for colours)



4.2 Process configuration

To illustrate scenarios of multistage experimentation, Tables 5, 6, and 7 provide different process configurations for two-stage, three-stage, and four-or-more-stage experimentation. Some scenarios have been explored by several researchers, whereas others require further investigation.

4.2.1 Two-stage experiments

Prior to discussing two-stage experiments, we would like to briefly address those involving a single process. A single process experiment allows us to randomly assign treatment combinations to experimental units. An experiment (Case 1A) can be done

using either completely randomised design or randomised design in block. Another type of design is a nested design (Case 1B), which involves different factors in each treatment. Typical designs (e.g., full factorial, fractional factorial, response surface, saturated, and supersaturated), are suitable for single process experiments, where one error term is used. [See more details in Box et al. (2005), Montgomery (2009) and Wu and Hamada (2000); for saturated design, see Lin (2003); for supersaturated design, see Lin (1993)].

For a two-stage experiment, a basic example is Case 2A which is arranged in split plot structure. Many researchers have studied this case in deep detail (see Box and Jones, 1992; Bingham and Sitter, 1999, 2001; Huang et al., 1998). Case 2B is arranged in split block structure. Studies on this structure include Vivacqua and Bisgaard (2004, 2009) and Miller (1997).

Other designs include Cases 2C–2H which are constructed based on both case 2A and 2B. Case 2C describes an assembly process where Stage 1 and Stage 2 are each prepared independently. Once experimental units from each stage are complete they are then assembled and the rest of the design is similar to split block structure.

In Cases 2D–2F experiments are conducted based on experimental units in a stage which are replicated only once, prepared, and then are split for replication in Stage 2. The treatment combination of Stage 2 factors is applied based on either split plot (2D), split block (2E), or a combination of the two (2F). The estimation of error terms for each becomes difficult, but the number of terms remains the same. Case 2G covers a situation in which each stage has its own nested factors. Analysis of this design can be done by combining the nested design analysis with split plot analysis.

Table 5 Several possible scenarios for two-stage experimentation (see online version for colours)





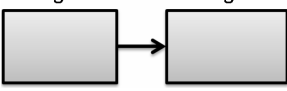
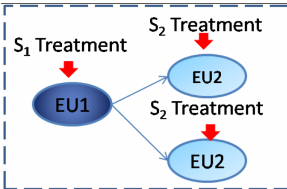
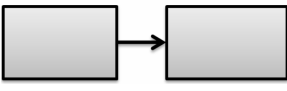
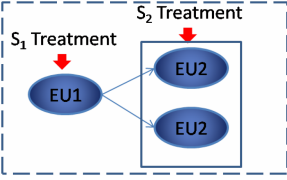
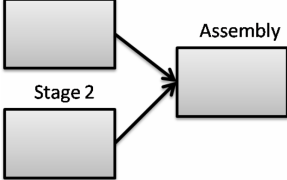
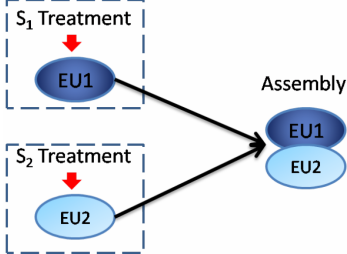
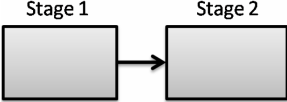
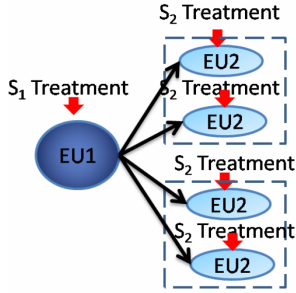
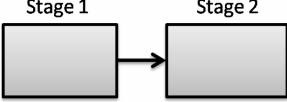
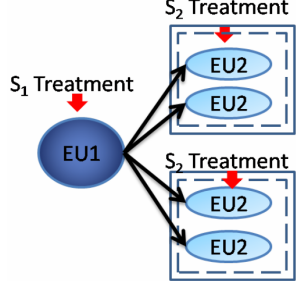
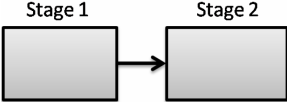
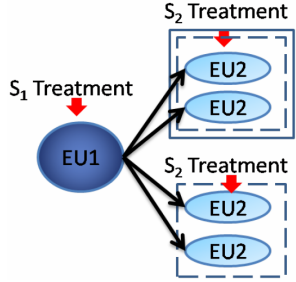
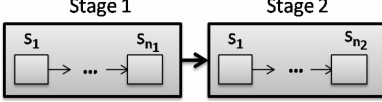
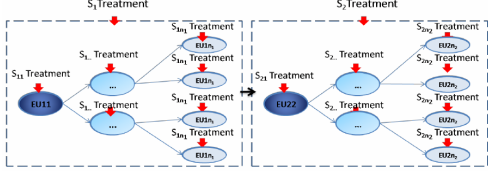
No.	Configuration	Experimental unit structure
1A	<p>Stage 1</p> 	<p>S₁ Treatment</p> 
1B	<p>Stage 1</p> 	<p>S₁ Treatment with nested factor treatment</p> 
2A	<p>Stage 1 → Stage 2</p> 	
2B	<p>Stage 1 → Stage 2</p> 	

Table 5 Several possible scenarios for two-stage experimentation (continued) (see online version for colours)

No.	Configuration	Experimental unit structure
2C		
2D		
2E		
2F		
2G		

4.2.2 Three-stage experiments


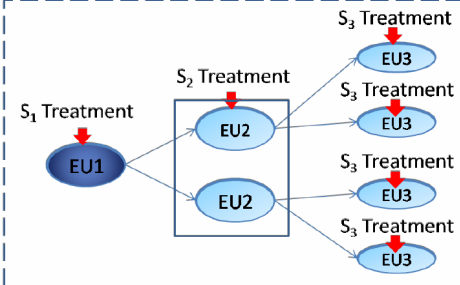
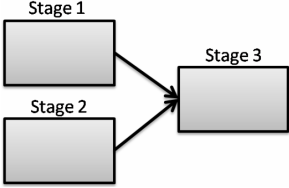
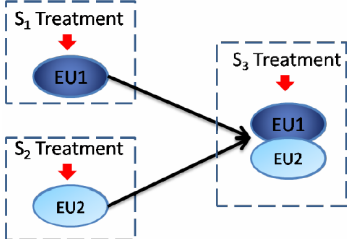
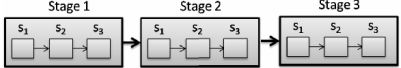
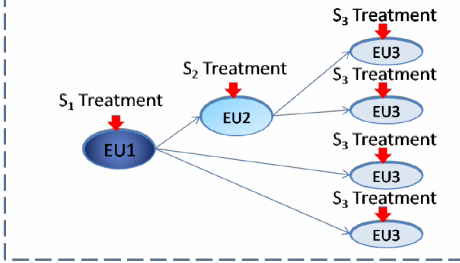
Conducting experiments on three-stage processes can be accomplished by extending ideas from two-stage experiments. The design structure of each stage can be any of the traditional designs. The simplest case (3A) is conducted with only split plot structure. After experimental units of Stage 1 are applied with a treatment combination of Stage 1 factors, they are split for Stage 2 and then for Stage 3. In Case 3B where only split block is used, at each stage the experimental units are split and regrouped for treatment. Cases 3C₁ and 3C₂ represent situations where both split plot and split block are used. Their analyses were shown in the previous section.

Case 3D is extended from Case 2C which is used in the assembly line. After assembling the experimental units for Stage 1 and Stage 2, the treatment combination of Stage 3 factors is applied randomly, in either split plot or split block arrangement. Case 3E represents new process development. Experimenters may consider adding or skipping Stage 2 in order to improve the process. If Stage 2 is added, there are other factors to be studied.

Table 6 Several possible scenarios for three-stage experimentation (see online version for colours)

No.	Configuration	Experimental unit structure
3A		
3B		
3C ₁		

Table 6 Several possible scenarios for three-stage experimentation (continued) (see online version for colours)

No.	Configuration	Experimental unit structure
3C ₂		
3D		
3E		

4.2.3 Four-or-more stage experiments

Cases 4A and 4B are the simplest arrangements for experiments in four stages. They are extended from Cases 3A and 3B. Case 4C is more complicated, as its structure is the combination of 3C₁, 3C₂ and 3D. At each stage, the design can be either type of design.

In summary, as shown in Tables 5, 6, and 7, in the simplest cases where there are only two stages, several scenarios (2A, 2B, 2C) have already been studied. Some multistage scenarios have also already been explored (3A, 3B, 3C). Experimenters can consider these cases and match them to their specific environments. However, there are many multistage scenarios which still need to be studied (e.g., 2D – 2H, 3D – 3E, and 4C). In these cases, some are simply extended from existing designs, some require modifications to the existing methodology, and some must be completely redesigned. When experiments involve three- or four-or-more stages, we still do not fully understand several issues surrounding design and analysis, especially when split plot and split block are combined.

Table 7 Several possible scenarios for four-stage experimentation (see online version for colours)

No.	Configuration	Experimental unit structure
4A		
4B		
4C		

5 Final remarks

In this paper, we introduced the concept of multistage experimentation in advanced manufacturing. We summarised the current methodology which is mainly based on split plot and split block arrangements for two-stage experimentation. It is recognised that two-stage experimentation is well studied and developed. These two-stage experiments are then extended to three-stage experiments or more. We then provided several scenarios for multistage experiments and showed that there are gaps between formal statistical design and analysis methods and experimentation in practice.

Here, we present some research opportunities that may have a high potential impact on research and applications. This is especially true when experiments involve three-or-more stages because both experiment design and data analysis become more complex. In addition, the research in this area cannot be generalised for multistage experiments.

- In terms of analysis, when a process become larger and larger (many stages), several questions arise. For example, is it reasonable or practical to use traditional statistical methods (ANOVA, GLS, etc.) to analyse these types of data? Are there any other techniques that can be used? In this case, it is difficult to understand the error structure for practitioners. When more stages are involved, more degrees of freedom are lost when estimating each error term. This leads to the loss of contrast information. Another analysis issue includes the design efficiency of multistage experiments compared to those with completely randomised designs or completely randomised designs in block.
- Fractional factorial design is a common type of design used in this area. Designs are developed based on maximum resolution and minimum aberration criteria which have been popularly used in broad applications. It is also necessary to develop a design based on an experimenter’s specific interest. Kulaheci et al. (2006) points out that there are other important criteria such as the maximum number of clear main effects, and maximum number of clear two-factor interaction effects for fractional factorial split plot design. Therefore, it is necessary to develop an algorithm to set up a design catalogue based on the criteria for these designs. We believe that it would

be inappropriate to generate a design based on a single criterion. A design catalogue with several criteria may provide more benefits to experimenters.

- Most designs used in multistage experimentation involve a single type of experimental design (e.g., two-level fractional factorial design, response surface method, or optimal design). Few studies focus on the combination of existing designs, although Vining et al. (2005) studied the combination of mixture design and response surface methods. One must also consider combined structures in traditional design, such as saturated design and fractional factorial design. The supersaturated designs are used when the number of runs is small compared to the number of interested factors. These combined designs may present other alternatives to experimenters when the focus of experiments is only on the main effects. They would allow experimenters to reduce costs more than using only fractional factorial design. Another potential area for research is the combination of traditional designs and optimal design. These designs may allow experimenters to use their prior information to gain new knowledge.
- The application of other statistical methods for product and process improvement is based on the complete randomisation principle. One example is in the area of design for reliability. Unlike data from general experimental design, the data from a reliability study is not normally distributed, is non-negative, and tends to be censored (Wu and Hamada, 2000). To incorporate the reliability data, two tasks need to be further explored for multistage experiment design: how to deal with estimation problems with censored data, and how to analyse reliability data with multiple error terms. Another application is gage reproducibility and repeatability (R&R). Although gage R&R studies have been used for years, little research has focused on how to conduct and analyse gage R&R based on split plot structure (Burdick et al., 2005).

Although statistical designs of experiments have been developed and used for decades in industry, they are not used much in the area of multistage environment. Multistage experiments represent a new class of experimental design used to overcome physical difficulties in experiments with randomisation restrictions. Significant advancements in these areas would allow experimenters to speed up both process and product improvement while revolutionising the use of quality engineering tools in industry.

References

- Acharya, N. and Nembhard, H. (2008) 'Statistical design and analysis for a three-step surface initiated polymerization process', *International Journal of Nanomanufacturing*, Vol. 2, No. 4, pp.331–345.
- Antolino, N., Hayes, G., Kirkpatrick, R., Muhlstein, C.L., Frecker, M.I., Mockensturm, E.M. and Adair, J.H. (2009a) 'Lost mold rapid infiltration forming of mesoscale ceramics: part 1, fabrication', *Journal of American Ceramic Society*, Vol. 92, No. 1, pp.S63–S69.
- Antolino, N., Hayes, G., Kirkpatrick, R., Muhlstein, C.L., Frecker, M.I., Mockensturm, E.M. and Adair, J.H. (2009b) 'Lost mold rapid infiltration forming of mesoscale ceramics: part 2, geometry and strength improvements', *Journal of American Ceramic Society*, Vol. 92, No. 1, pp.S70–S78.
- Arnouts, H., Goos, P. and Jones, B. (2009) 'Design and analysis of industrial strip-plot experiments', *Quality and Reliability Engineering International*, Special Issue, Vol. 26, No. 2, pp.127–136.

- Bingham, D. and Sitter, R. (1999) 'Minimum aberration two-level fractional factorial split-plot designs', *Technometrics*, Vol. 41, No. 1, pp.62–70.
- Bingham, D. and Sitter, R. (2001) 'Design issues in fractional factorial split-plot experiments', *Journal of Quality Technology*, Vol. 33, No. 1, pp.2–15.
- Bingham, D. and Sitter, R. (2003) 'Fractional factorial split-plot design for robust parameter experiments', *Technometrics*, Vol. 45, No. 1, pp.80–89.
- Bingham, D., Schoen, E.D. and Sitter, R.R. (2004) 'Designing fractional factorial split plot experiments with few whole plot factors', *Journal of the Royal Statistical Society, Series C*, Vol. 53, No. 2, pp.325–339.
- Bingham, D., Sitter, R., Kelly, E., Moore, L. and Olivas, J.D. (2008) 'Factorial design with multiple levels of randomization', *Statistica Sinica*, Vol. 18, No. 2, pp.493–513.
- Bisgaard, S. (2000) 'The design and analysis of $2^{k-p} \times 2^{q-r}$ split-plot experiments', *Journal of Quality Technology*, Vol. 32, No. 1, pp.39–56.
- Box, G. and Jones, S. (1992) 'Split plots for robust product and process experimentation', *Journal of Applied Statistics*, Vol. 19, No. 1, pp.3–26.
- Box, G.E., Hunter, J.S. and Hunter, W.G. (2005) *Statistics for Experimenters: Design, Innovation, and Discovery*, 2nd ed., John Wiley & Sons, New Jersey.
- Burdick, R., Borror, C. and Montgomery, D. (2005) *Design and Analysis of Gauge R&R Studies*, ASA-Siam, Philadelphia.
- Butler, N.A. (2004) 'Construction of two-level split-plot fractional factorial designs for multistage processes', *Technometrics*, Vol. 46, No. 4, pp.445–451.
- Cheng, C.S. and Tsai, P.W. (2009) 'Optimal two-level regular fractional factorial block and split plot design', *Biometrika*, Vol. 96, No. 1, pp.83–93.
- Federer, W.T. and King, F. (2007) *Variations on Split Plot and Split Block Experiment Designs*, John Wiley & Sons, Canada.
- Fisher, R. (1925) *Statistical Methods for Research Workers*, Oliver and Boyd, Edinburgh.
- Freibert, F., Olivas, J. and Coonley, M. (2002) 'Researchers cast first 'spiked' plutonium alloy', *Actinide Res. Quarterly*, Vol. 2, No. 2, pp.1–6.
- Gilmour, S.G. (2006) 'Response surface designs for experiments in bioprocessing', *Bio-metrics*, Vol. 62, No. 2, pp.323–331.
- Gilmour, S.G. and Trinca, L.A. (2003) 'Row-column response surface designs', *Journal of Quality Technology*, Vol. 35, No. 2, pp.184–193.
- Goos, P. (2002) *The Optimal Design of Blocked and Split-Plot Experiments*, Springer-Verlag, New York.
- Goos, P. and Donev, A.N. (2007) 'Tailor-made split plot design for mixture and process variables', *Journal of Quality Technology*, Vol. 39, No. 4, pp.326–339.
- Goos, P. and Vandebroek, M. (2001) 'Optimal split plot', *Journal of Quality Technology*, Vol. 33, No. 4, pp.436–450.
- Goos, P. and Vandebroek, M. (2004) 'Outperforming completely randomized designs', *Journal of Quality Technology*, Vol. 36, No. 1, pp.12–26.
- Hinkelmann, K. and Kempthorne, O. (2008) *The Design and Analysis of Experiments: Volume 1 Introduction to Experimental Design*, 2nd ed., Wiley-Interscience, New Jersey.
- Huang, P., Chen, D. and Voelkel, J.O. (1998) 'Minimum-aberration two-level split plot designs', *Technometrics*, Vol. 40, No. 4, pp.314–326.
- Jones, B. and Goos, P. (2009) 'D-optimal design of split-split-plot experiments', *Biometrika*, Vol. 96, No. 1, pp.67–82.
- Jones, B. and Nachtsheim, C.J. (2009) 'Split plot designs: what, why and how', *Journal of Quality Technology*, Vol. 41, No. 4, pp.22–43.
- Ju, H. and Lucas, J. (2002) ' L^k factorial experiments with hard-to-change and easy-to-change factors', *Journal of Quality Technology*, Vol. 34, No. 4, pp.411–2002.

- Kemphorne, O. (1952) *The Design and Analysis of Experiments*, John Wiley & Sons, New Jersey.
- Kowalski, S.M. (2002) '24 run split plot experiments for robust parameter design', *Journal of Quality Technology*, Vol. 34, No. 4, pp.399–410.
- Kowalski, S.M., Cornell, J.A. and Vining, G.G. (2002) 'Split plot designs and estimation methods', *Technometrics*, Vol. 44, No. 1, pp.72–79.
- Kulahci, M., Ramirez, J.G. and Tobias, R. (2006) 'Split-plot fractional designs: is minimum aberration enough?', *Journal of Quality Technology*, Vol. 38, No. 1, pp.56–64.
- Letsinger, J.D., Myers, R.H. and Lentner, M. (1996) 'Response surface methods for bi-randomization structures', *Journal of Quality Technology*, Vol. 28, No. 4, pp.381–397.
- Lin, D. (2003) *Handbook of Statistics in Industry*, pp.33–73, Chap. Industrial Experimentation for Screening, North Holland, New York.
- Lin, D.K.J. (1993) 'A new class of supersaturated designs', *Technometrics*, Vol. 35, No. 1, pp.28–31.
- McLeod, R.G. and Brewster, J.F. (2004) 'The design of blocked fractional factorial split-plot experiments', *Technometrics*, Vol. 46, No. 2, pp.135–146.
- McLeod, R.G. and Brewster, J.F. (2006) 'Blocked fractional factorial split-plot experiments for robust parameter design', *Journal of Quality Technology*, Vol. 38, No. 3, pp.267–279.
- Mee, R.W. and Bates, R.L. (1998) 'Split-plot designs: experiments for multistage batch processes', *Technometrics*, Vol. 40, No. 2, pp.127–140.
- Miller, A. (1997) 'Strip-plot configuration of fractional factorials', *Technometrics*, Vol. 39, No. 2, pp.153–161.
- Montgomery, D.C. (2009) *Design and Analysis of Experiments*, 7th ed., John Wiley & Sons, New Jersey.
- Paniagua-Quinones, C. and Box, G.E.P. (2008) 'Use of strip-strip-block design for multistage processes to reduce costs of experimentation', *Quality Engineering*, Vol. 20, No. 1, pp.46–52.
- Parker, P.A., Kowalski, S.M. and Vining, G.G. (2006) 'Classes of split plot response surface designs for equivalent estimation', *Quality and Reliability Engineering International*, Vol. 22, No. 3, pp.291–305.
- Parker, P.A., Kowalski, S.M. and Vining, G.G. (2007) 'Construction of balanced equivalent estimation second-order split plot designs', *Technometrics*, Vol. 49, No. 1, pp.56–65.
- Peterson, J.J., Snee, R.D., McAllister, P.R., Schofield, T.M. and Carella, A.J. (2009) 'Statistics in pharmaceutical development and manufacturing', *Journal of Quality Technology*, Vol. 41, No. 2, pp.111–147.
- Shoemaker, A.C., Tsui, K.L. and Wu, J.C.F. (1991) 'Economical experimentation methods for robust design', *Technometrics*, Vol. 33, No. 4, pp.415–427.
- Taguchi, G. (1987) *System of Experimental Design*, UNIPUB, New York.
- Trinca, L. and Gilmour, S.G. (2001) 'Multistratum response surface design', *Technometrics*, Vol. 43, No. 1, pp.25–33.
- Vining, G.G., Kowalski, S.M. and Montgomery, D.C. (2005) 'Response surface designs within a split plot structure', *Journal of Quality Technology*, Vol. 37, No. 2, pp.115–129.
- Vivacqua, C.A. and Bisgaard, S. (2004) 'Strip-block experiments for process improvement and robustness', *Quality Engineering*, Vol. 16, No. 3, pp.495–500.
- Vivacqua, C.A. and Bisgaard, S. (2009) 'Post-fractionated strip-block designs', *Technometrics*, Vol. 51, No. 1, pp.47–55.
- Wu, C. and Hamada, M. (2000) *Experiments: Plannings, Analysis, and Parameter Design Optimization*, John Wiley & Sons, New York.
- Yates, F. (1937) *The Design and Analysis of Factorial Experiments*, Imperial Bureau of Social Science, England.

- Yuangyai, C. and Nembhard, H.B. (2009) 'Design of experiments: a key to innovation in nanotechnology', in Ahmed, W. and Jackson, M. (Eds.): *Emerging Nanotechnologies for Manufacturing*, William Andrew, Burlington.
- Yuangyai, C. and Nembhard, H.B. (2013) *Optimal Fractional Factorial Split Plot Design for Multistage Manufacturing*, Working paper.
- Yuangyai, C., Nembhard, H., Hayes, G., Antolino, N. and Adair, J.H. (2009) 'Yield improvement for lost mold rapid infiltration forming process by a multi-stage fractional factorial split plot design', *International Journal of Nanomanufacturing*, Vol. 3, No. 4, pp.351–367.