

Passive and Active Methods of Islanding for PV systems

Tomáš Skočil, Oriol Gomis-Bellmunt, Daniel Montesinos-Miracle,
Samuel Galceran-Arellano and Joan Rull-Duran
Centre d'Innovació Tecnològica en Convertidors Estàtics i Accionaments (CITCEA-UPC)
Departament d'Enginyeria Elèctrica, Universitat Politècnica de Catalunya,
ETS d'Enginyeria Industrial de Barcelona
Av. Diagonal, 647, Pl. 2. 08028 Barcelona, Spain
Barcelona, Spain
Phone: +34 934016727
Fax: +34 934017433
Email: skocil.tomas@gmail.com, oriol.gomis@upc.edu, montesinos@citcea.upc.edu,
galceran@citcea.upc.edu, rull@citcea.upc.edu
URL: <http://www.citcea.upc.edu>

Keywords

<<Simulation>>, <<Control methods for electrical systems>>, <<Renewable energy systems>>, <<Pulse Width Modulation (PWM)>>, <<Modelling>>, <<Photovoltaic>>, <<Power supply>>, <<Protection device >>, <<Regulation>>, <<Alternative energy>>, <<Single phase system>>, <<Voltage Source Converter (VSC)>>.

Abstract

This paper presents a review of some techniques for islanding detection, especially by using inverter based DG applications and it also focuses on several islanding detection methods for a single-phase current-control voltage inverter working with a PV system connected into the grid. It is deliberated a single-phase inverter with maximum power of 5 kW. Islanding detection methods are investigated, simulated and evaluated in MATLAB / SIMULINK.

Introduction

Anti-islanding capability is an important requirement for distributed generators. It is necessary to detect when the system operates in an island and to disconnect it from the grid as soon as possible. The island can occur when a part of grid is electrically isolated from the power system but the part with island is energized by distributed generators. The islanding detection is important for many reasons - a possibility to damage customer equipments and distributed generator, hazard for line-workers, islanding may interfere with restoration of normal services for neighboring customers.

The islanding detection is important for all distributed generation systems. Many algorithms have already been developed in last 10 years. All these methods can be divided into 4 categories [1], [2], [4].

- passive inverter-resident methods
- active inverter-resident methods
- active methods not resident in the inverter
- methods based on the use of communications between the grid and PV inverter

This paper is only focused on passive and active inverter-resident methods. There are not shown neither the active methods not resident in the inverter because it needs more equipment or methods based on the use of communication for their robustness and communication safety reasons. These 2 last methods are not easy and cheap and it means another expenses.

Passive detection methods [1], [4] have a large non-detection zone (NDZ) and that is not a significant anti-islanding protection. Two main system parameters frequency and voltage at the point of common coupling (to assign the size of NDZ) can change their values depending on a variable load connected to the grid. If an inverter has the capability of over/under voltage protection and over/under frequency

protection, we say it has the basic islanding detection capability. Active detection methods should be also used to decrease the size of NDZ. But the main disadvantage of active methods is the injecting of a disturbance signal into the grid [2], [13]. For a faultless and correct use is better to combine more islanding detection methods based on another working process [16]-[21].

This report presents a review and simulations of the size of non-detection zone (over/under voltage and over/under frequency method), PLL based active method [6], [7], [13] and active frequency drift method [8], [12] for a single-phase inverter of active power about 5 kW. The same passive and active parameters for simulations have been used and the same time when the island occurs and the same instant when disturbance of active methods is injected. The tables comparing these methods are shown at the end of this paper.

System configuration

The topology of the grid, the current-controlled inverter working with PV system and parallel RLC load is shown in Figure 1. The node where all parts are connected is called the point of common coupling (PCC). Voltage and voltage frequency are measured in this node and used for islanding detection and also as references for the control of inverter. For accurate control of inverter is also necessary to measure the output inverter current.

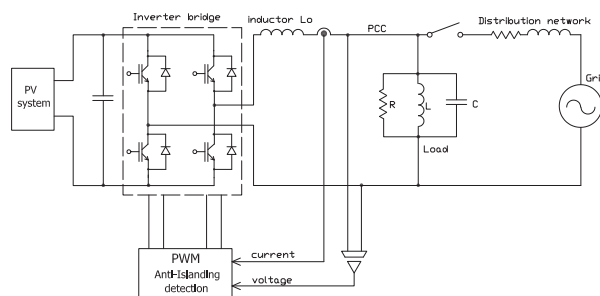

Figure 1: Voltage source inverter connected to local load and distribution network

The inverter inductor is used for a smooth sine-wave of inverter current. For objective simulations it is also used the grid impedance between the PCC and the grid. R, L, C are resistance, inductance and capacitance of parallel RLC load.

Anti-islanding

Islanding test conditions

Islanding of the grid connected generators (photovoltaic system) can occur when the part of utility system having such generators is disconnected from the main grid and independent generators keep to energize the isolated part. The system consists PV panels, an inverter, a local load (parallel RLC), a switch (breaker, fuse, ...) and the grid. In this paper the distribution generation is considered to be in unity power factor operation. This unity power factor condition combined with passive parameters of parallel RLC load and frequency in (1)-(4) consider the worst case for islanding detection when the active power of load matches to output power of distribution generation. For simulations the worst case is used as test conditions according to UL1741, IEEE 929 and IEEE 1547 [9], [10], [16]:

1. The power generated by DG should match the RLC load power, $\Delta P = 0$ and $\Delta Q = 0$.
2. Resonant frequency of the RLC load is the same as grid line frequency ($f = 50Hz$).
3. The quality factor Q_f of RLC load is set to be 2.5. The quality factor is defined as that the reactive power stored in L or C is Q_f times the active power consumed in R.

Under these conditions, when the grid is disconnected, the distributed generation and RLC load will resonate at nominal voltage and frequency to form an island, unless there is a mechanism to drive voltage at PCC or frequency out of their nominal range. Load definition can be represented as

$$f = \frac{1}{2\pi\sqrt{LC}} \quad (1)$$

$$R = \frac{V^2}{P} \quad (2)$$

$$L = \frac{V^2}{2\pi f Q_f P} \quad (3)$$

$$C = \frac{Q_f P}{2\pi f V^2} \quad (4)$$

where

R - effective load resistance [Ω], L - effective load inductance [H], C - effective load capacitance [F], P - active power [W], Q_f - quality factor, f - grid frequency [Hz].

The values of frequency and magnitude of the voltage at the PCC after grid disconnection (islanding condition) depend heavily on the local load characteristic.

$$P_{load} = \frac{V_{PCC}^2}{R} \quad (5)$$

$$Q_{load} = V_{PCC}^2 \left(\frac{1}{\omega L} - \omega C \right) \quad (6)$$

Equations (5) and (6) describe the active and reactive power consumed by the RLC load. If the active power demand of the load and active power production of PV system are not the same at the instant when the breaker opens, then the voltage at PCC must decrease or increase until $P_{PV} = P_{load}$. It is similar, if the reactive power demand of load and reactive power production are not matched at the time when the grid is disconnected. The frequency ω at PCC must change until $Q_{PV} = Q_{load}$. The mechanism, by which this happens, is that the PV inverter will seek a frequency at which the current-voltage phase angle of the load equals that of the PV system. Such voltage and frequency changes can be detected by over/under voltage and over/under frequency relays.

Difficulties appear when a load demand and PV generation are close. Then frequency or voltage changes can be insufficient to enable detection by PV inverter. It is the reason why it is necessary to develop islanding techniques which can detect these cases when the powers of PV and load are closely matched. It is the aim of all islanding detection methods to reduce the non-detection zone near to zero.

Anti-islanding methods

A. Over/under voltage and over/under frequency method

All grid-connected inverters are required to have an over/under voltage and an over/under frequency protection. Limits when the inverter should be switched off can be different in each country. An example of values for most of countries in Europe is in Table I [15], [16].

Table I: Voltage and frequency limits

Value	Minimum	Maximum
Frequency	$f_{min} = 49Hz$	$f_{max} = 51Hz$
Voltage	$V_{min} = 0.88pu$	$V_{max} = 1.1pu$

Power balance at PCC is given by equations (7) and (8). If $\Delta P_{load} = \Delta P_{DG}$ and if $\Delta Q_{load} = \Delta Q_{DG}$ there is no active/reactive power difference between the PV system and the grid.

$$P_{load} = P_{DG} + \Delta P \quad (7)$$

$$Q_{load} = Q_{DG} + \Delta Q \quad (8)$$

The behavior of the system when the grid is disconnected depends on ΔP and ΔQ . If the resonant frequency of RLC load is the same as grid line frequency, the linear load does not absorb reactive power. Active power is directly proportional to the voltage. After the disconnection of the grid, the active power of the load is forced to be the same of the PV system, hence the grid voltage change into

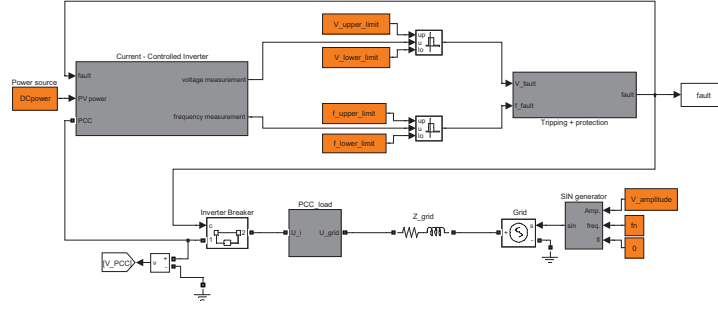

Figure 2: Topology of load, grid and inverter with required over/under voltage and over/under frequency detection

$$V' = K \cdot V \quad (9)$$

where

$$K = \sqrt{P_{DG}/P_{load}} \quad (10)$$

If $\Delta P_{DG} > \Delta P_{load}$ there is an increase of the amplitude of the voltage and if $\Delta P_{DG} < \Delta P_{load}$ there is a decrease of the amplitude.

A small ΔP results in an insufficient change in voltage amplitude and small ΔQ results in an inadequate change in frequency to effectively disconnect the PV and prevent islanding. The probability of small values of ΔP and ΔQ for the NDZ is significant and protection devices cannot detect an island reliably. In general, over/under voltage and over/under frequency devices alone are generally considered to be insufficient anti-islanding protections. It is possible to calculate the NDZ from the mismatches of active and reactive power and setting the threshold values for voltage amplitude and for frequency.

B. PLL based active method

The method is based on the modification of sine-wave current reference obtained from PLL. A sinusoidal signal multiplied by distortion gain is injected to the inverter current angle. The inverter current angle and distorted signal are summed. From this new value of current angle the sine-wave current reference is made. The sinusoidal signal injection can be done with positive or negative sign. The current reference for the inverter must be synchronized with the voltage at PCC [13], [14].

C. Active frequency drift

It is a method which can be easily implemented into a inverter with a microprocessor-based controller and it adds no costs to such a system. Inverters give the output current slightly distorted into the utility at the frequency slightly lower or higher than the voltage frequency at PCC. For example - during first half of sinusoidal waveform of output inverter current is with frequency slightly higher than the frequency of the grid voltage is. When the inverter current reaches zero, it remains zero for time before the beginning of next half-cycle [8], [12].

Simulation of anti-islanding detection method

Model passive and active parameters used for simulations are shown in table II. These parameters were used purposely for comparing different detection methods.

A. Over/under voltage and over/under frequency method

Figures 2 and 3 show the topology for detection under/over voltage and under/over frequency with inverter shutdown. Voltage at PCC can only change when the grid is disconnected and DC power and power of load are not the same. If the load power is smaller then the voltage at PCC increases and if the load power is higher then voltage at PCC decreases. Voltage difference depends on the difference between these powers.

Active power of parallel RLC load was changed for an assignment of NDZ for constant DC power of $P_{DC} = 2000$ W without using another detection method. It was determined limit bounds of detection

Table II: Used model parameters for comparison of different islanding methods

Parameter	Value	Parameter	Value
Active power of load [W]	2000	Nominal frequency [Hz]	50
Resonance frequency of inverter load [Hz]	50	RMS voltage [V]	230
Quality factor [-]	2.5	Power of PV system [W]	2000
Resistance of inverter load [Ω]	26.45	Resistance of smoothing inductor [Ω]	0.1
Inductance of inverter load [mH]	33.7	Inductance of smoothing inductor [H]	5e-3
Capacitance of inverter load [μF]	300.86	Limit of over voltage [V]	253
Cut-off time of breaker [s]	0.8	Limit of under voltage [V]	202.4
Resistance of the grid [Ω]	0.2	Limit of over frequency [Hz]	51
Inductance of the grid [H]	0.2e-3	Limit of under frequency [Hz]	49

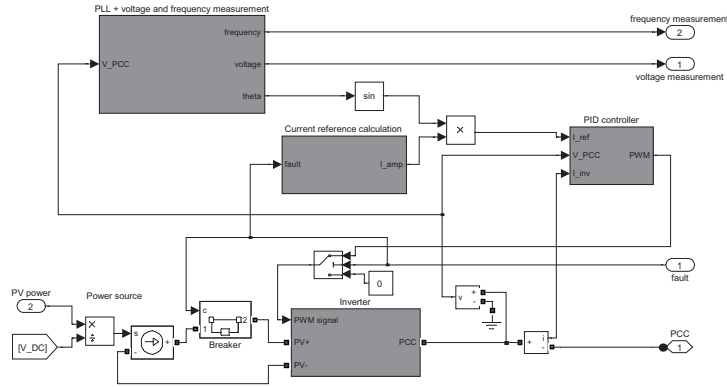

Figure 3: Inverter with PLL and current control loop

capability 1600 W (over voltage - $1.1V_{RMS}$) and 2550 W (under voltage - $0.88V_{RMS}$). If the load power is between these values, the system is not able to detect an island operation. If the load power is out of the range, the islanding detection is very reliable. Plots for NDZ bounds 1600 W a 2550 W are in Figure 4(a). The grid was connected until the instant $t = 0.8s$ (breaker opens in zero current). We can see the current magnitudes corresponding to DC and load power. Grid current is the difference between current of load and inverter current. Inverter current must be the same with load current after grid disconnection. When the islanding operation is detected, the inverter is switched off immediately. This time is about 0.03 s. In the plot of voltage at PCC is obvious that voltage increases to the limit $1.1V_{RMS} = 253$ V after grid disconnection for smaller load power than DC power of PV system and for higher load power the voltage decreases until it reaches $0.88V_{RMS} = 202.4$ V.

Load active power of $P_{load} = 2000$ W is used for a verification of under/over frequency detection. Values of load resonance frequency were changed. There exist 2 bounds for $f_o = 49$ Hz and $f_o = 51$ Hz because passive parameters of load determine the frequency reference for the control loop of inverter. (If resonance frequency is $f_o = 50$ Hz, load does not take reactive power when the grid is disconnected). In measured frequency plot in Figure 4(b) we can see that the frequency decreases for $f_o = 49$ Hz after grid disconnection until it reaches $f = 49$ Hz then the inverter is disconnected. For $f_o = 51$ Hz frequency of voltage at PCC increases after grid disconnection to $f = 51$ Hz where the islanding operation is detected and the inverter is switched off. The plots are shown in Figure 4(b).

From these simulations it is possible to assign the bounds of non-detection zone which are shown in Figure 5. For all load parameters inside this zone it is impossible to detect an islanding operation. When we use load power $P_{DC} = 2000$ W, we obtain detection limits:

$$P_{load} = 1600 \text{ W} \Rightarrow |P_{DC} - P_{load}| = 400 \text{ W} \Rightarrow 20\% \text{ of } P_{DC} \quad (11)$$

$$P_{load} = 2550 \text{ W} \Rightarrow |P_{DC} - P_{load}| = 550 \text{ W} \Rightarrow 27.5\% \text{ of } P_{DC} \quad (12)$$

and for frequency:

$$f_o = 49 \text{ Hz} \Rightarrow |f_n - f_o| = 1 \text{ Hz} \Rightarrow 2\% \text{ of } f_n \quad (13)$$

$$f_o = 51 \text{ Hz} \Rightarrow |f_n - f_o| = 1 \text{ Hz} \Rightarrow 2\% \text{ of } f_n \quad (14)$$

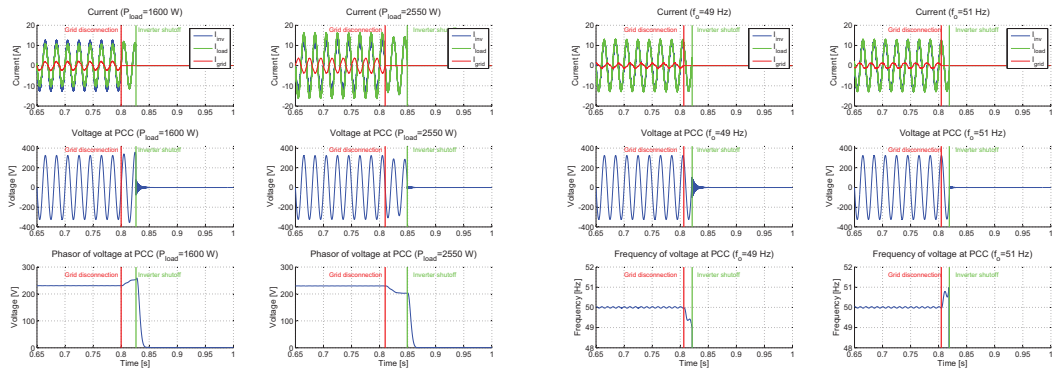

(a) Load power 1600 W a 2550 W and $f_0 = 50$ Hz (b) Load reson. freq. 49 Hz, 51 Hz and $P_{load} = 2000$ W

Figure 4: Over/under voltage and over/under frequency method - $Q_f = 2.5$, breaker opens at $t = 0.8$ s

This detection method has a quite big zone where the detection is impossible, especially for active power. It is the reason why it is necessary to use another subsidiary methods.

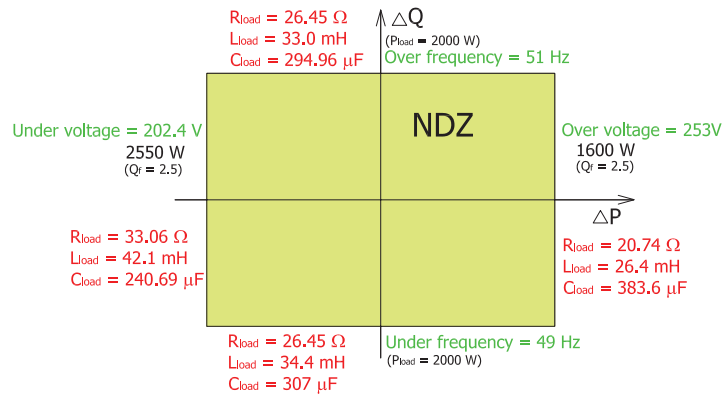

Figure 5: Non-detection zone for $0.88V_{RMS} = 202.4$ V, $1.1V_{RMS} = 253$ V, $f = 49$ Hz and $f = 51$ Hz

B. PLL based active method

It was done a verification for load parameters $P_{DC} = P_{load} = 2000$ W, $f_0 = 50$ Hz, $Q_f = 2.5$ which is one of the worst detectable islanding operations. The previous method cannot detect this case.

For an assessment of limit from where it is possible to detect an islanding operation the distortion gain was gradually increased from the lowest values. We obtained the distortion gain limit 0.2 when islanding operation can be detected. The ability of detection is for the distortion gain higher than 0.2. On the other hand we need to have this value as small as it is possible. The higher is this value, the more distorted is the sine wave obtained from current reference calculation. There the second harmonic is added. Disturbances are invoked all the time also when the system does not work in islanding operation.

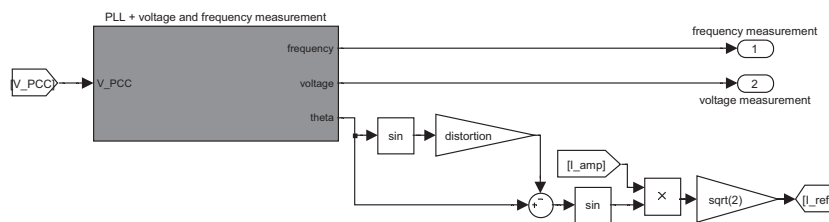

Figure 6: Topology for the PLL based active method

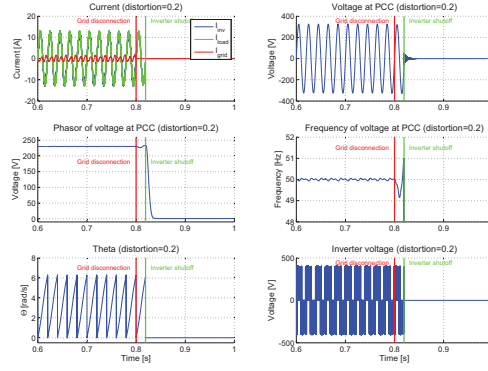

Figure 7: PLL based active method - distortion gain 0.2, $P_{DC} = P_{load} = 2000$ W, $f_0 = 50$ Hz, $Q_f = 2.5$, breaker opens $t = 0.8$ s

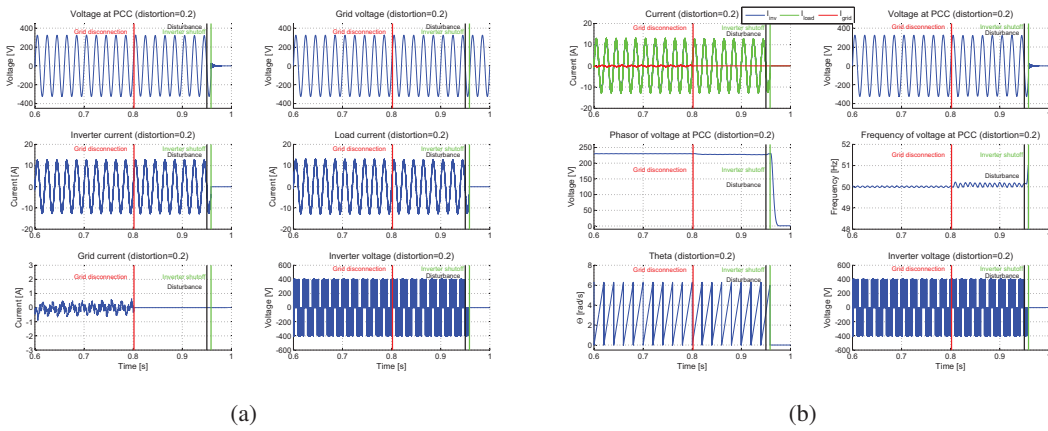

Figure 8: PLL based active method - distortion gain 0.2, $P_{DC} = P_{load} = 2000$ W, $f_0 = 50$ Hz, $Q_f = 2.5$, breaker opens $t = 0.8$ s, the beginning of disturbance $t = 0.95$ s

This method is quite fast and it can be used as an advantage of an interrupted injection of added signal. Then the distortion could be used only in short intervals. Time between the beginnings of two following distortion interval must be shorter than detection time which is required for disconnection in standards. It causes less disturbances which can be used for parallel inverters in different time which means smaller total disturbance at PCC.

Figure 6 shows how the disturbing signal is created. The plots for simulation, where the breaker opens at $t = 0.8$ s and the disturbing signal is injected into the control loop of inverter at instant $t = 0.95$ s, are shown in Figures 8(a) and 8(b). This is only for verification of this model. In real system could be used a pulse generator which generates disturbance for example only 2 of 14 periods for 50 Hz signal.

In Figures 8(b) and 8(a) it is possible to see obviously the disconnection of the grid in the grid current plot. From the instant $t = 0.8$ s the current is zero. From $t = 0.8$ s until $t = 0.95$ s there is no disturbing signal injected into the current reference. Also in this time period the current of inverter and the current of load must be exactly the same. From $t = 0.95$ s disturbance is injected and reaction time from the beginning of disturbance is 0.008 s. How we can see in this case, an over frequency protection reacted. After time instant $t = 0.958$ s the inverter is switched off.

C. Active frequency drift method

Topology for making of the frequency drift signal for the active frequency drift method is shown in Figure 9. The simulation was done also for one of the worst case with parameters of load $P_{DC} = P_{load} = 2000$ W, $f_0 = 50$ Hz, $Q_f = 2.5$.

For an assessment of bounds from which is possible to detect islanding operation, frequency change was increased subsequently from zero from the nominal value of frequency of voltage at PCC. If the frequency difference of the injected current is smaller than 2 Hz from nominal system frequency (50 Hz) then this system does not detect an islanding operation for assigned load parameters. If the frequency difference between the frequency of current and the frequency of voltage at PCC is 2.5 Hz, the system

Table III: Detection time for detection method

Detection method	Detection time
A1. Over/under voltage	0.03 s; 0.05 s
A2. Over/under frequency	0.02s; 0.02 s
B. PLL based active method	0.008 s
C. Active frequency drift	0.009 s

need zero NDZ, no more expenses (it is required in standards), it does not inject any disturbing signals into PCC even partial.

PLL based active method (B) - detection time after the beginning of injected disturbing signal is small (fast method); it is enough to inject disturbance only for a short period of time smaller than it is required in standards to switch off the inverter; a possibility to use more inverters working in parallel with disturbances in different time periods (less disturbance at PCC); almost zero NDZ (only worse detectable for higher values of Q_f).

Active frequency drift (C) - (almost the same as for PLL based active method) - detection time from the beginning of disturbance application is quite short, disturbance can be injected only 1 or 2 periods during time which is shorter than required time in standards to detect the islanding operation; a possibility of using more parallel inverters connected into PCC when the disturbing signal is injected in different time periods (smaller disturbance at PCC); almost zero NDZ (only worse detectable for higher values of Q_f).

Disadvantages:

Over/under voltage (A1) and over/under frequency method (A2)- too large NDZ where the detection is impossible - in most cases it is necessary to use another detection methods.

PLL based active method (B) - second harmonic is added into current reference (inverter current) also when the system does not work under islanding operation.

Active frequency drift (C) - disturbance is injected into PCC although when the system does not work under islanding conditions.

An overview of shown detection methods in this paper is in Table IV.

Table IV: Comparison of simulated method

	Detection method			
	A1	A2	B	C
short detection time	YES	YES	YES	YES
injected disturbance	NO	NO	YES	YES
zero NDZ	NO	NO	YES	YES
more parallel inverters	YES	YES	NO ¹	NO ¹

Conclusion

This paper has given a short overview of possible methods used to detect islanding operation for PV inverters and it should show a sense of detection of islanding operation and a simulation principle for a few detection methods. It exists more and different detection methods based on different principles. For better comparison of shown methods it would better to do more simulations for different parameters (for example: load power etc.) and to compare detection time for those parameters.

This paper has presented some passive and active methods how to detect the island, especially for inverters based on DG applications. Because the problem of anti-islanding protection and islanding detection is too large, it is also important to know exact parameters of impedance between the grid and PCC. The impedance magnitude has a big influence and the system could fail for higher values (for example 1Ω) if another large load is connected.

Future work could include: 1) further experimental validation of the modelling results, 2) investigation of an effect of non-linear components and connecting another loads, 3) minimize the size of NDZ but to avoid all inadmissible influences for whole system.

¹In case when a interrupted disturbance is not used

References

- [1] Mango F. D., Liserre M., Dell'Aquila A. and Pigazo A.: Overview of anti-islanding algorithms for PV systems, part I: Passive methods, 12th International Power Electronics and Motion Control Conference EPE-PEMC 2006, 2006, pp. 1878–1883
- [2] Mango F. D., Liserre M. and Dell'Aquila A.: Overview of anti-islanding algorithms for PV systems, part II: Active methods, 12th International Power Electronics and Motion Control Conference EPE-PEMC 2006, 2006, pp. 1884–1889.
- [3] Blaabjerg F., Teodorescu R., Liserre M. and Timbus A. V.: Overview of control and grid synchronization for distributed power generation systems vol. 53, no. 5, pp. 1398–1409, Oct. 2006.
- [4] Wilsun X., Konrad M. and Sylvain M.: An assessment of distributed generation islanding detection methods and issues for Canada, no. CETCVarennes 2004-074 (TR) 411-INVERT, p. 67, July 2004
- [5] Ye Z., Kolwalkar A., Zhang Y., Du P. and Walling R.: Evaluation of anti-islanding schemes based on non-detection zone concept, vol. 19, no. 5, pp. 1171–1176, Sept. 2004
- [6] Silva S. M., Lopes B. M., Filho B. J. C., Campana R. P. and Bosventura W. C., Performance evaluation of PLL algorithms for single-phase grid-connected systems, in 39th IAS Annual Meeting Industry Applications Conference Conference Record of the 2004 IEEE, vol. 4, 3–7 Oct. 2004, pp. 2259–2263
- [7] Ciobotaru M., Teodorescu R. and Blaabjerg F.: Improved PLL structures for single-phase grid inverters, no. 6, pp. 1–6
- [8] Ropp M. E., Begovic M. and Rohatgi A.: Analysis and performance assessment of the active frequency drift method of islanding prevention, IEEE Transaction on Energy Conversion, vol. 14, no. 3, pp. 810–816, Sept. 1999
- [9] IEEE Recommended Practice for Utility Interface of Photovoltaic (PV) Systems, IEEE Std., 3 April 2000
- [10] IEEE recommended practice for utility interface of residential and intermediate photovoltaic (PV) systems, IEEE Std., 30 Nov. 1987
- [11] Chunjiang Z., Wei L., Guocheng S. and Weiyang W.: A novel active islanding detection method of grid-connected photovoltaic inverters based on current-disturbing, in Proc. CES/IEEE 5th International Power Electronics and Motion Control Conference IPEMC'06, vol. 3, Aug. 2006, pp. 1–4
- [12] Lopes L. A. C. and Sun H.: Performance assessment of active frequency drifting islanding detection methods, IEEE Transaction on Energy Conversion, vol. 21, no. 1, pp. 171–180, March 2006
- [13] Ciobotaru M., Agelidis V. and Teodorescu R., Accurate and less-disturbing active anti-islanding method based on PLL for grid-connected PV inverters, in Proc. IEEE Power Electronics Specialists Conference PESC 2008, 15–19 June 2008, pp. 4569–4576
- [14] Arruda L. N., Silva S. M. and Filho B. J. C.: PLL structures for utility connected systems, in Thirty-Sixth IAS Annual Meeting Industry Applications Conference Conference Record of the 2001 IEEE, vol. 4, 30 Sept.–4 Oct. 2001, pp. 2655–2660
- [15] VDE, Selbsttätige schaltstelle zwischen einer netzparallelen eigenerzeugungsanlage und den öffentlichen niederspannungsnetz - DIN V VDE V 0126-1-1 (VDE V 0126-1-1), Deutsche Kommission Elektrotechnik Elektronik Informationstechnik, no. VDE V 0126-1-1, pp. 1–15, Februar 2006
- [16] IEC-International Electrotechnical Commission, Photovoltaic (PV) systems - characteristics of the utility interface (second edition), International standard (CEI IEC 61727), pp. 1–24, 2004. www.iec.ch
- [17] Jang S.I., Kim K. H.: An islanding detection method for distributed generations using voltage unbalance and total harmonic distortion of current, vol. 19, no. 2, pp. 745–752, April 2004.
- [18] Blaabjerg F., Teodorescu R., Liserre M., Timbus A. V.: Overview of control and grid synchronization for distributed power generation systems, vol. 53, no. 5, pp. 1398–1409, Oct. 2006.
- [19] Ranade J. S., Prasad N. R., Omick S., Kazda L. F.: A study of islanding in utility-connected residential photovoltaic systems. I. models and analytical methods, IEEE Transaction on Energy Conversion, vol. 4, no. 3, pp. 436–445, Sept. 1989.
- [20] Ranade J. S., Prasad N. R., Omick S., Kazda L. F.: A study of islanding in utility-connected residential photovoltaic systems. II. case studies, IEEE Transaction on Energy Conversion, vol. 4, no. 3, pp. 446–452, Sept. 1989.
- [21] Ropp M. E., Begovic M., Rohatgi A., Kern G. A., Bonn S., Gonzalez R. H.: Determining the relative effectiveness of islanding detection methods using phase criteria and non detection zones, IEEE Transaction on Energy Conversion, vol. 15, no. 3, pp. 290–296, Sept. 2000.