



AENSI Journals

Australian Journal of Basic and Applied Sciences

ISSN:1991-8178

Journal home page: www.ajbasweb.com

Design of Integrated Ultra-Wideband (UWB) Bandpass Filter and U-Shape Defected Microstrip Structure (DMS)

¹A.A.M. Bahar, ²Z. Zakaria, ³N. Saifullah, ⁴M.M.N.M.A. Fadillah, ⁵M.A. Mutalib

¹Student Researcher, University of Technical Malaysia Malacca, Telecommunication Engineering, Faculty of Electronics and Computer Engineering, Malacca, Malaysia.

²Doctor & Researcher, University of Technical Malaysia Malacca, Telecommunication Engineering, Faculty of Electronics and Computer Engineering, Malacca, Malaysia.

³Student Researcher, University of Technical Malaysia Malacca, Telecommunication Engineering, Faculty of Electronics and Computer Engineering, Malacca, Malaysia.

⁴Student Researcher, University of Technical Malaysia Malacca, Telecommunication Engineering, Faculty of Electronics and Computer Engineering, Malacca, Malaysia.

⁵Student Researcher, University of Technical Malaysia Malacca, Telecommunication Engineering, Faculty of Electronics and Computer Engineering, Malacca, Malaysia.

ARTICLE INFO

Article history:

Received 25 August 2014

Received in revised form

19 September 2014

Accepted 29 October 2014

Available online 16 November 2014

Keywords:

Ultra-Wideband, microstrip bandpass filter, notch response, defected microstrip structure (DMS).

ABSTRACT

This paper presents a new class of a compact ultra-wideband (UWB) bandpass filter with Defected Microstrip Structure (DMS) to produce bandpass and band reject characteristics simultaneously. The bandpass filter produces a wideband frequency from 3.1 GHz to 10.6 GHz with a return loss, S_{11} better than -15 dB and insertion loss, S_{21} of around 0.1 db. While, the DMS exhibits a band reject response, better than -20 dB at a frequency of 5.78 GHz. Thus, the integrated BPF and DMS will produce wideband bandpass and band reject response simultaneously in the same structure. The design is simulated on a Roger Duroid RO4350 with a dielectric constant, ϵ_r of 3.48 and a thickness of 0.508 mm. The optimum topology of DMS with U-shape exhibits high selectivity, sharp response as well as high attenuation in the stopband. This new class design of Chebyshev bandpass filter with DMS is useful to remove any undesired signals in any ultra-wideband communication system.

© 2014 AENSI Publisher All rights reserved.

To Cite This Article: A.A.M. Bahar, Z. Zakaria, N. Saifullah, Design of Integrated Ultra-Wideband (UWB) Bandpass Filter and U-Shape Defected Microstrip Structure DMS. *Aust. J. Basic & Appl. Sci.*, 8(17): 547-551, 2014

INTRODUCTION

In 2002, the Federal Communications Commission (FCC) approved the use of ultra-wideband (UWB) (range of 3.1 - 10.6 GHz) for commercial purposes. Ultra-wide band (UWB) systems have been receiving wide attention from both academy and industry for the prominent advantages, such as high speed data rate, extremely low spectral power density and high precision ranging (Saito *et al*, 2003). Recently, the development of new UWB filters has increased via different methods and structures (Hsu *et al*, 2005).

One of the key issues in the UWB range is the interference with wireless local area networks (WLANs). Sharp selectivity and capabilities to avoid interference from existing radio signals are highly demanded to the UWB BPF within the range defined by the FCC. The filter using an interdigital stepped impedance resonator is designed.

The filter design exhibited a poor performance in term of selectivity and difficulty in adjusting the bandwidth. But, this design can be produced a good insertion loss in the passband. The improvement can be made by optimizing the spacing between resonators (Ji *et al*, 2008). The UWB bandpass filter can be produced by a combination of prototype of the highpass filter consists of a parallel LC-resonator in series and two shunt inductors, while the lowpass filter is formed by two parallel LC-resonators and three shunt capacitors (Tang *et al*, 2012). But, these methods have some disadvantages in term of grounding because it uses defected ground structure (DGS) to produce the low pass response (Tang *et al*, 2012).

A microstrip bandpass filter with highly selective has been reported (Chen *et al*, 2011), which design using a $\lambda/4$ short-circuited stubs filter with a 5th order to produce UWB. This design connects the lines between short-circuited stubs meandered to reduce the size but the 3 dB passband covers the range of 2.7 GHz to 10.7 GHz which is apparently not good enough. The characteristic of DMS is quite similar with DGS and both methods

Corresponding Author: A.A.M. Bahar, Student Researcher, University Technical Malacca Malaysia, Telecommunication Engineering, Faculty of Electronic and Computer Engineering, Malacca, Malaysia.
E-mail: amyrulazuan@yahoo.com

produce narrow sharp stopband frequency response. DMS is more easily integrated with other microwave circuits, and has an effectively reduced circuit size compared with DGS and simultaneously, DMS exhibits the properties of slow-wave, rejecting microwaves in certain frequencies and has an increasing electric length of certain circuits which are similar to the well-known DGS but without any manipulation of the ground plane (Zakaria *et al*, 2012) (Xiao *et al*, 2011). In this paper, a new topology of integration between BPF and DMS using the microstrip structure is presented. The improvement of the design is carried out by introducing the U-shape structure in order to provide small size and better performance in term of transmission and reflection response.

Design of UWB Bandpass Filter:

The filter design is based on a circuit model for an optimum distributed highpass filter with 5 short circuited stubs in 0. The characteristic impedances of the short-circuited stubs are defined by Z_1, Z_2, Z_3 , and the characteristic impedances for the connecting lines are defined by $Z_{1,2}$ to $Z_{4,5}$. The terminal impedance is defined as Z_0 . The electrical length of the connecting lines (θ_c) is twice that of the stubs (θ_s) at the lower cutoff frequency which resulting the smallest amount of interactions between adjacent stubs or junctions. The design equations for determining these characteristics admittances are described in 0. The bandpass filter is designed to have a fractional bandwidth (FBW) 109.49 % at a midband frequency 6.85 GHz and the desired electric length is 40.73° . A 50 impedance is chosen which give $= 1/50$ mhos. The filter circuit model is shown in Figure 1 (a). Based on element value of UWB with short-circuited stub (passband ripple = 0.1 dB), the filter was synthesized to obtain the desired circuit parameters, i.e. the characteristic impedances for the short-circuited stubs and the connecting lines, which are listed in Table 1.

The simulated frequency response of the filter is shown in Figure 1(b). In general, the performance of the frequency response is seen to be good agreement with the modeling circuit of transmission line bandpass filter with an optimum distributed highpass.

Table I: Design parameters for an optimum distributed highpass filter with 5 short-circuited stubs.

Stub line impedance	Connecting line impedance
$Z_1 = Z_5 = 78.02 \Omega$	$Z_{1,2} = Z_{4,5} = 56.94 \Omega$
$Z_2 = Z_4 = 43.8 \Omega$	$Z_{2,3} = Z_{3,4} = 60.37 \Omega$
$Z_3 = 39.6 \Omega$	$Z_0 = 50 \Omega$

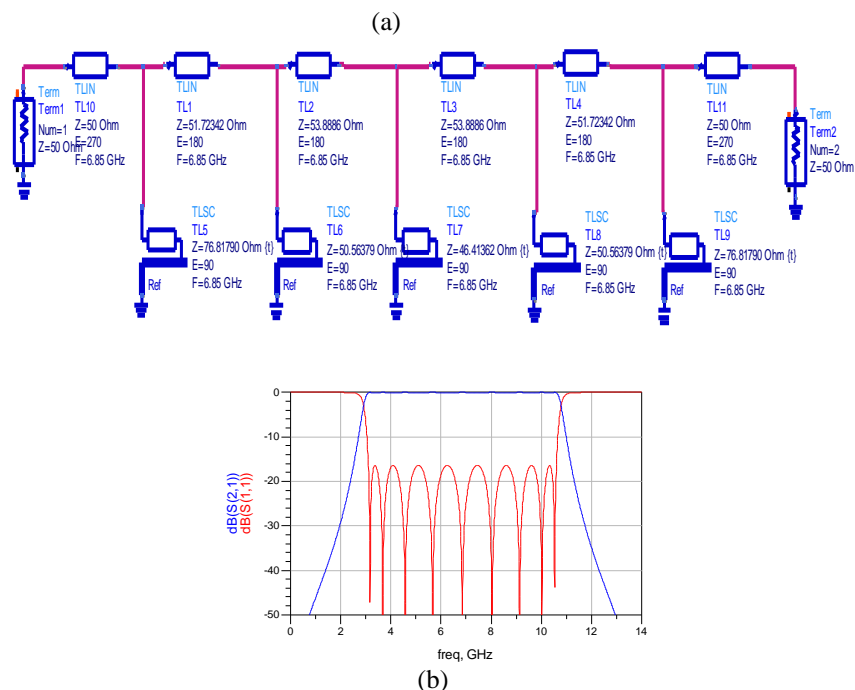

Fig. 1: Modelling circuit of the proposed ultra wideband bandpass filter based on optimum distributed highpass filter (b) Simulated of ideal frequency response of the bandpass filter.

The design parameters for microstrip 5th stub bandpass filter are summarized in Table 2 and 3. The design of the filter is implemented using microstrip on the Roger Duroid 4350 shown in Figure 2. Figure 3 shows the photograph of the fabricated UWB BPF. It has a compact size of 66 mm \times 26 mm. Figure 4 shows the simulated and measured results on the UWB BPF. The simulated return loss (S_{11}) is better -15 dB and insertion loss (S_{21})

of -0.1 dB in the frequency range of 3.1 GHz – 10.6 GHz are obtained. In the experimental results, the frequency range of 2.95 GHz – 10.08 GHz with a return loss (S_{11}) and insertion loss (S_{21}) of better than -10 dB and -3 dB are measured. However, there is nevertheless a noted frequency shift of 335 MHz ($\approx 5.31\%$) from the center frequency, which is due to the variations of dielectric permeability and manufacturing tolerance.

Table II: Width and length for stub line.

Stub line width(mm)	Stub line length(mm)
$W_1 = W_5 = 0.512389$	$L_1 = L_5 = 6.83061$
$W_2 = W_4 = 1.112480$	$L_2 = L_4 = 6.61711$
$W_3 = 1.275950$	$L_3 = 6.57638$

Table III: Width and length for transmission line.

Line width(mm)	Line length(mm)
$W_{1,2} = W_{4,5} = 1.071790$	$L_{1,2} = L_{4,5} = 12.1562$
$W_{2,3} = W_{3,4} = 1.000840$	$L_{2,3} = L_{3,4} = 12.0962$
$W_{in} = 1.132990$	$L_{in} = 6.611710$

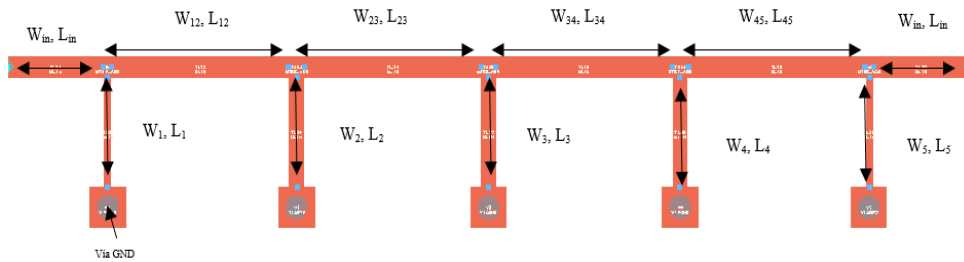

Fig. 2: Physical layout UWB BPF.

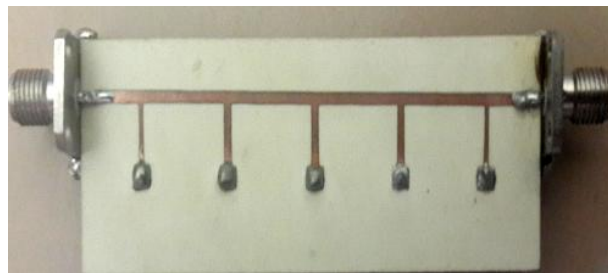

Fig. 3: Photograph of the fabricated UWB BPF.

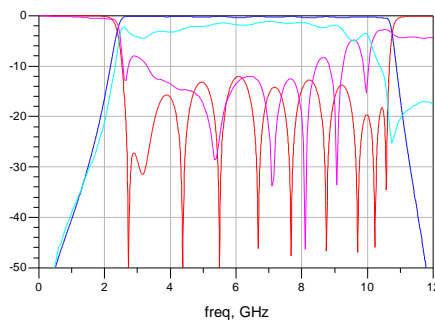

Fig. 4: Simulated and measured results of the fabricated UWB BPF.

Bandpass Filter With Dms:

Interference from undesired radio signals in the UWB band can be removed by implementing the notch response into the UWB BPF presented in section II. Notch response at the passband UWB can be realized by using defected microstrip structure integrated with the UWB. In order to demonstrate the band reject from DMS U-shape structure shown in Figure 5, a bandstop filter with a single band is designed.

The structure of DMS consists of U-shape slot which defect the microstrip line by disturbing the flow of electromagnetic (EM) flow of the design. The structure produced a narrow bandwidth and sharp rejection at a specific frequency. Figure 6 shows that if the length, L of the DMS structure increases its frequency resonance

decrease and width of DMS structure decrease its bandwidth will narrow. To investigate of DMS consists of U-shape, the length of L and w are analyzed in detail shown in Figure 6.



Fig. 5: U-shape DMS.

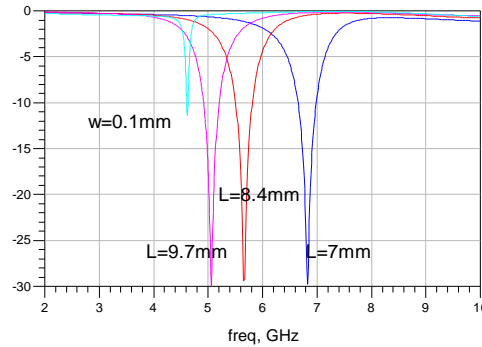

Fig. 6: Simulated (S_{21}) responses of the U-shape structure by adjusting the L and w.

The dimensions of U-shape structure are summarized as follows: $L = 8.4$ mm and $w = 0.4$ mm. Figure 7 and Figure 8 show the simulated and photograph structure of integrated UWB BPF with DMS respectively. Figure 9 shows the simulated and measured results on the UWB BPF integrated with U-shape DMS. The U-shape DMS simulated return loss (S_{11}) is better than -15 dB in the frequency range of 2.238 GHz – 10.54 GHz are obtained. In the experimental results, the frequency range of 2.238 GHz – 9.842 GHz with a return loss (S_{11}) better than -20 dB are measured. However, there is nevertheless a reduced bandwidth of 692 MHz ($\approx 1.13\%$) from the frequency range, which is due to the variations of dielectric permeability and manufacturing tolerance.

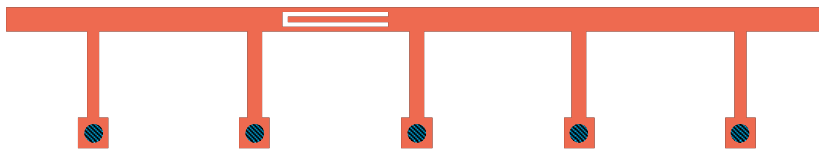

Fig. 7: Physical layout UWB BPF integrated with U-shape DMS.



Fig. 8: Photograph of the fabricated UWB BPF integrated with U-shape DMS.

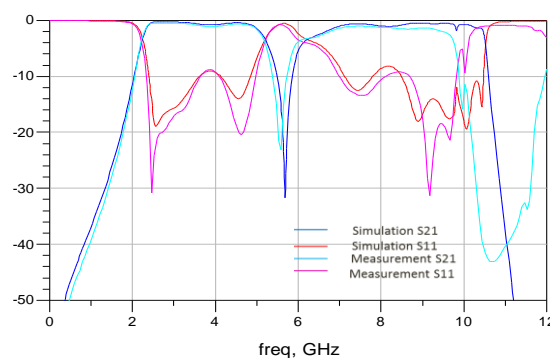

Fig. 9: Simulated and measured results of the fabricated UWB BPF integrated with U-shape DMS.

Conclusion:

A structure of bandpass filter integrated with DMS using microstrip technology has been designed, simulated and fabricated. The proposed design of U-shape produced better performance and has the advantages in terms of simple topology, compact size, low loss and excellent performance. The DMS design has the benefit with reduction of overall size as well as the undesired radiation can be avoided.

ACKNOWLEDGMENT

The authors would like to express profound gratitude to Dr. Zahriladha Bin Zakaria as his supervision for his invaluable support, encouragement and providing the guidance throughout the research and parameter analysis.

REFERENCES

- Chen, L.N., Y.C. Jiao, H.H. Xie and F.S. Zhang, 2011. "A Novel G-Shaped Slot Ultra-Wideband Bandpass Filter with Narrow Notched Band," *Progress In Electromagnetics Research Letters*, 20: 77-86.
- First note and order, Federal Communication Commission, Feb. 14, 2002. "Revision of Part 15 of the Commission's Rules Regarding Ultra-Wide-band Transmission System," ET-Docket 98-153.
- Hong, J.S., 2002. "Microstrip Filters for RF/Microwave Applications" 2nd Edition. New Jersey, Wiley.
- Hsu, C.L., F.C. Hsu and J.T. Kuo, 2005. "Microstrip Bandpass Filters for Ultra-Wideband (UWB) Wireless Communications," *IEEE MTT-S International Digest*, pp. 679-682.
- Ji, M.Z., Q.X. Qu and F.C. Chen, 2008. "A Compact UWB Bandpass Filter using Pseudo-Interdigital Stepped Impedance Resonators," *International Conference on Microwave and Millimeter Wave Technology*, 1: 344-346.
- Saito, A., H. Harada and A. Nishikata, 2003. "Development of Band Pass Filter for Ultra Wideband (UWB) Communication Systems," *Proceeding IEEE Conference Ultra Wideband Systems and Technology*, pp: 76-80.
- Tang, W.C., S.M. Yang, X. Wang, C. Wang and Y.L. Chow, 2012. "A Novel UWB Bandpass Filter using Highpass and Lowpass Filters," *4th International High Speed Intelligent Communication Forum (HSIC)*, pp. 1-2.
- Xiao, J.K. and W.J. Zhu, 2011. "New Defected Microstrip Structure Bandstop Filter," *Progress In Electromagnetics Research Symposium Proceedings*, pp: 1471-1474.
- Zakaria, Z., N.A. Shairi, R. Sulaiman and W.Y. Sam, 2012. "Design of Reconfigurable Defected Ground Structure (DGS) for UWB Application," *IEEE Asia-Pacific Conference on Applied Electromagnetics (APACE)*, 2: 195-198.