

# First Order Integral Sliding Mode Control for Active and Reactive Current of A Multilevel Inverter Based Distributed Generation Unit

A. Elnady<sup>1,2</sup>

<sup>1</sup> Department of Electrical Engineering  
University of Sharjah  
Sharjah- United Arab Emirates  
e-mail: [ayelnady71@gmail.com](mailto:ayelnady71@gmail.com)

<sup>2</sup> Royal Military College (Adjunct)  
Electrical and Computer Engineering Department  
Kingston, Ontario- Canada

**Abstract.** This paper presents an innovative control scheme for Distributed Generation Systems, DGS, using an efficient version of the first order Sliding Mode Control, SMC. The control law of the SMC is modified in order to improve the tracking and reduce the chattering over the conventional SMC. The modification is focused on the definition of the sliding manifold, sliding surface, which contains an integral term of the error not a differential term like the conventional SMC. The proposed control scheme is applied to a multilevel diode clamped inverter based Distributed Generation Unit, DGU. The proposed control scheme is developed to control the active and reactive currents injected or absorbed by the power grid. Simulation results are provided to prove the viability of the proposed formulation and practicality of the presented sliding mode controller for the distributed generation system.

## Key words

Multilevel inverter, sliding mode control, active and reactive current.

## 1. Introduction

The distributed generation system has been proliferated in distribution systems world-wide [1]. This wide-spread of distributed generated system emanates as a result of a shortage for enough supply to meet the increasing demands in power systems [2]. The distributed generation unit can be existing in several forms such as synchronous generators and inverters [2]. Nowadays, the inverters are more favorable than the traditional generators because of its ability for fast control and intrinsic short circuit protection.

The regular inverter causes much distortion and requires a complex passive filter, which influences the output voltage and overall operation of the distribution system. In this paper, the adopted topology is a 5-level diode clamped inverter that generates a waveform close to a sinusoid. The operation of this multilevel inverter is illustrated in [3]

The literature shows several control techniques that have been presented and used to control the DGS. The most common control scheme called vector control, which depends on voltage orientation of the DGU with respect to the system voltage [4]. This scheme controls the active and reactive current/power through two decoupled control loops; each loop is provided with one or more PI controllers, but the main drawback of vector control is its susceptibility the system operating condition to the parameters of PI controllers [4]. Adaptive total SMC is also utilized to control the current and voltage of stand-alone DG. The adaptive total sliding SMC is particularly used to achieve minimum total injected harmonics and maximum power factor. A regular sliding mode control is utilized with the inverter to control its output instantaneous power and stabilize its output voltage, but it suffers from high chattering with steady state error [5]. Recently, a new control scheme called Direct Power Control, DPC, has been applied to the regular inverter based DGU, to directly control the injected active and reactive power [6], [7]. The main advantage of this scheme is that the control loops are directly dealing with power not currents and voltages. The DPC suffers from utilizing a hysteresis controller that leads to much distortion in the output. In addition, this scheme relies on the estimation of the converter flux and its dependability on the step time for simulation. A Look Up Table Direct Power Control, (LUT-DPC), which is considered as an improved version of DPC, is presented to reduce the drawback of hysteresis controller and stabilize the switching frequency [8]. The SMC is merged with the DPC to precisely control both active and reactive power so as to improve the tracking performance [9], but this proposed controller is mathematically complex and affects the controller fastness of its practical implementation; in addition to the chattering is still a serious concern in the presented results.

The contribution of this paper is manifested in using integral SMC instead of the conventional SMC since the conventional SMC does not guarantee zero steady state error [10], but the integral SMC guarantees better tracking and accuracy rather than the conventional first order SMC. In addition, it presents the use of the integral SMC to operate a multilevel inverter as a DGU. The 5-level diode-clamped inverter is selected as a topology of the distributed generation unit, DGU, to ease the passive filter design; and consequently it will not affect overall performance of the whole system. This paper is composed of five sections. The second section depicts the system under study for this research work along with the topology of the DGU. The third section shows the mathematical development of the control law in light of the implementation of integral SMC. The fourth section depicts the simulation results for active and reactive currents injected by the distributed generation unit. The last section summarizes the findings of the paper.

## 2. Distribution System Under Study

The system under study is part of a distribution system, where the DGS is attached to a Point of Common Coupling, PCC, through a step-up matching star-star transformer with a turn ratios of 1:5. The system and the topology of the DGU are shown in Fig. 1-a and Fig. 1-b, respectively. The operation of the 5-level diode clamped inverter is realized by the multicarrier PWM technique. The adopted technique for the multicarrier PWM is the in-phase disposition [11]. The voltage waveforms for the power system, multilevel inverter before and after the transformer are shown in Fig. 1-c.

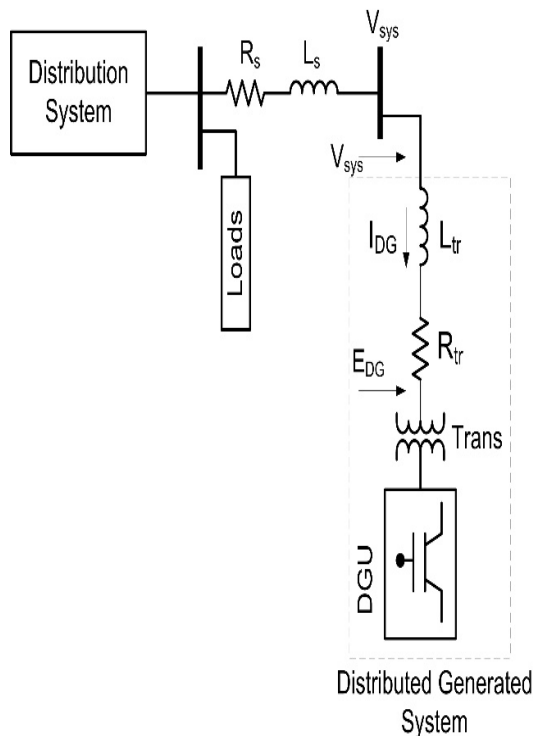

Fig. 1-a: Distribution system under study

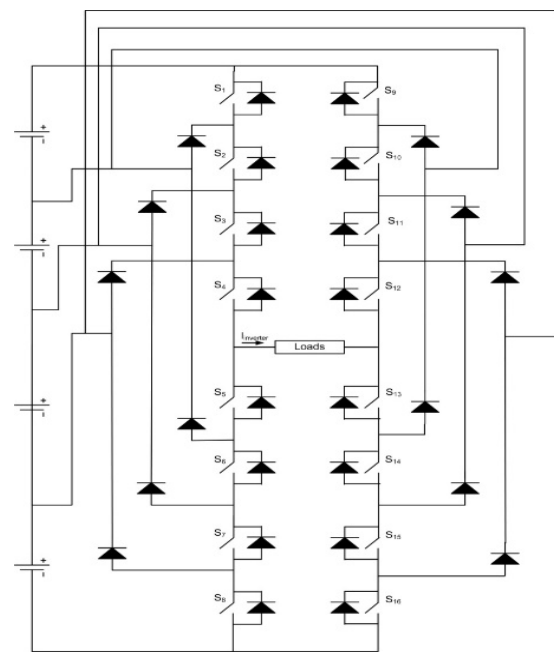

Fig. 1-b: Topology of DGU

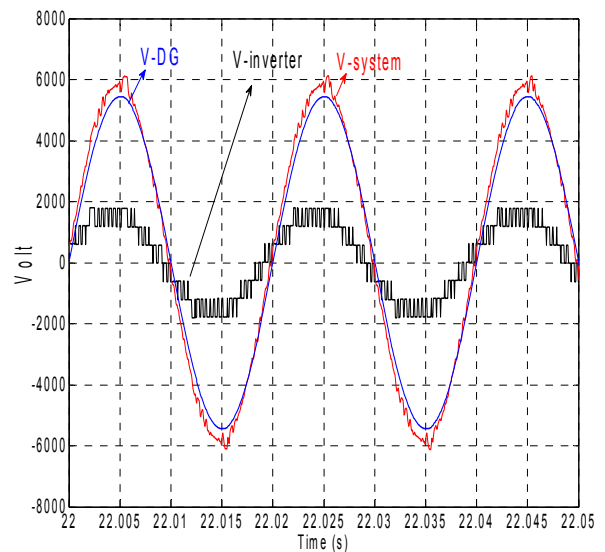

Fig. 1-c: System voltage, DGU voltage and inverter voltage when  $I_{d-DG}=400$  A and  $I_{q-DG}=500$  A for integral SMC

Fig. 1: Distribution system under study along with the DGU

The distribution system parameters considered for the simulation results are shown below,

Table 1: Data of the distribution system under study and DGU

System voltage = 6.6 kV, $R_s = 0.06 \Omega/\text{km}$ , $L_s = 0.0002$ H/km, Distribution feeder length = 15 kms
$R_{\text{loads}} = 50 \Omega$ , $L_{\text{load}} = 0.1$ H for each phase, (constant impedance load)
Voltage ratio = 1.32/6.6 kV, $S_{tr} = 2.5$ MAV, $R_{tr} = 0.01$ pu, $L_{tr} = 0.05$ pu
$V_{dc}$ for inverter = 1200 V, PWM frequency = 1.25 kHz, $R_p = 1$ M $\Omega$ , Power MOSFET IRF 840

### 3. Mathematical Development of the Proposed Control Law of Integral SMC

The system depicted in Fig. 1-a is being represented by a state space model as,

$$pI_{d-DG} = -\frac{R_{tr}}{L_{tr}} I_{d-DG} + \omega I_{q-DG} + \frac{1}{L_{tr}} (V_{d-sys} - E_{d-DG}) \quad (1)$$

$$pI_{q-DG} = -\omega I_{d-DG} - \frac{R_{tr}}{L_{tr}} I_{q-DG} + \frac{1}{L_{tr}} (V_{q-sys} - E_{q-DG}) \quad (2)$$

$$pV_{dc}^2 = \frac{3E_{d-DG} I_{d-DG}}{C} + \frac{3E_{q-DG} I_{q-DG}}{C} + \frac{V_{dc}^2}{2CR_p} \quad (3)$$

where  $L_{tr}$  is the inductance of the transformer,  $R_{tr}$  is the resistance of the transformer,  $V_{sys}$  is the voltage of the system,  $E_{DG}$  is the output voltage of the inverter or DGU, after the transformer,  $I_{d-DG}, I_{q-DG}$  are two components of the DGU current at the d-q frame,  $C$  is the equivalent capacitor of the inverter and  $R_p$  is the parallel resistance at the DC side of the inverter. The state-space linearized model for (1) to (3) around a stable operating point is given as,

$$\begin{bmatrix} pI_{d-DG} \\ pI_{q-DG} \\ pV_{dc}^2 \end{bmatrix} = \begin{bmatrix} -\frac{R_{tr}}{L_{tr}} & \omega & 0 \\ \omega & -\frac{R_{tr}}{L_{tr}} & 0 \\ \frac{3E_{d-DG}}{C} & \frac{3E_{q-DG}}{C} & \frac{2}{2CR_p} \end{bmatrix} \begin{bmatrix} I_{d-DG} \\ I_{q-DG} \\ V_{dc}^2 \end{bmatrix} + \begin{bmatrix} -\frac{1}{L_{tr}} & 0 \\ 0 & -\frac{1}{L_{tr}} \\ 0 & 0 \end{bmatrix} \begin{bmatrix} E_{d-DG} \\ E_{q-DG} \end{bmatrix} + \begin{bmatrix} \frac{1}{L_{tr}} \\ 0 \\ 0 \end{bmatrix} [V_{d-sys}]$$

$$[y] = \begin{bmatrix} 1 & 0 & 0 \\ 0 & 1 & 0 \end{bmatrix} \begin{bmatrix} I_{d-DG} \\ I_{q-DG} \\ V_{dc}^2 \end{bmatrix} \quad (4)$$

The last row is not important because  $V_{dc}$  is considered to be constant; it is represented by a regulated DC source. The last equation can be rewritten in the state-space form as,

$$\dot{x} = Ax + Bu + Fd \quad (5)$$

$$y = Cx$$

where

$$x = \begin{bmatrix} I_{d-DG} \\ I_{q-DG} \end{bmatrix}, u = \begin{bmatrix} E_{d-DG} \\ E_{q-DG} \end{bmatrix}, d = [V_{d-sys}], F = \begin{bmatrix} \frac{1}{L_{tr}} \\ 0 \end{bmatrix},$$

$$A = \begin{bmatrix} -\frac{R_{tr}}{L_{tr}} & \omega \\ \omega & -\frac{R_{tr}}{L_{tr}} \end{bmatrix}, \quad (6)$$

$$B = \begin{bmatrix} -\frac{1}{L_{tr}} & 0 \\ 0 & -\frac{1}{L_{tr}} \end{bmatrix}, C = \begin{bmatrix} 1 & 0 \\ 0 & 1 \end{bmatrix}$$

The conventional SMC defines the sliding manifold as,

$$S = (\lambda + \frac{d}{dt})^{n-1} e, \text{ where } n \text{ is the system order} \quad (7)$$

The sliding manifold in this work does not consider the differential part as mentioned in (7), but it introduces an integral term, which is defined as,

$$S = (\lambda + \int)^{n-1} e \quad (8)$$

The integral term in the previous sliding surface guarantees the minimum steady state error compared to the conventional SMC when the state variables slide over the sliding trajectory, sliding mode.

where  $e$  is defined as the error between the reference and the actual state variables,

$$e = I_{ref} - I_{DG} \quad (9)$$

The stability of the system, (in the reaching mode and sliding mode), along with the proposed controller is guaranteed through the utilization of the positive definite Lyapunov function defined as,

$$V(x) = \frac{1}{2} S(x)^T S(x) \quad (10)$$

For a stable system, the time derivative of Lyapunov function is written as,

$$\dot{V}(x) = \frac{\partial V(x)}{\partial S} * \frac{\partial S}{\partial t} = S(x)^T * \dot{S}(x) \leq 0 \quad (11)$$

$$\dot{S}(x) = \frac{\partial S(x)}{\partial x} * \frac{\partial x}{\partial t} = \frac{\partial S(x)}{\partial x} * \dot{x} = \frac{\partial S(x)}{\partial x} [Ax + Bu + Fd] \leq 0 \quad (12)$$

The control is applied on the current in the d-q frame, so  $I_d$  and  $I_q$  are considered as the state variables and  $n$  in (8) equals 2. The new sliding manifold is expressed as,

$$S = (\lambda + \int) e = \lambda e + \int e dt = \lambda(x_{ref} - x) + \int (x_{ref} - x) dt \quad (13)$$

$$\frac{\partial S(x)}{\partial x} = \frac{\partial}{\partial x} \left[ \lambda(x_{ref} - x) + \int (x_{ref} - x) dt \right] \quad (14)$$

$$= -\lambda + \frac{\partial}{\partial x} \left[ \int -x dt \right] \approx -\lambda - \frac{\Delta x \Delta t}{\Delta x} \approx -\lambda$$

$$S(x)^T \frac{\partial S(x)}{\partial x} [Ax + Bu + Fd] \leq 0 \rightarrow \quad (15)$$

$$S(x)^T * (-\lambda) [Ax + Bu + Fd] = 0$$

Choose  $u$  for a negative definite such that  $\dot{V}(x) < 0$  then the trajectory of the state variables converges to the proposed sliding manifold. The input amplitude should be chosen sufficiently large to realize the above inequality (11) and (12). The typical choice to realize the above inequality is to assume the control law given as [12],

$$u(t) = u_c(t) + u_{eq}(t) \quad (16)$$

where the first term of this control law is introduced to force the state trajectory to reach the sliding manifold, reaching mode, and the second term is responsible for making the derivative of the sliding manifold equals to zero as given in (12) and detailed in (15), sliding mode. The first term  $u_c(t)$  is chosen as proposed in [12],

$$u_c(t) = \alpha * \text{sign}(S) \quad (17)$$

while the second term is obtained from (15) as,

$$u_{eq}(t) = [B]^{-1} [Ax + Fd] = 0 \quad (18)$$

Eqs. (16-18) give the required control law for the proposed integral SMC to let the state variables,  $I_{d-DG}$  and  $I_{q-DG}$  track the desired values,  $I_{d-ref}$  and  $I_{q-ref}$ , with a minimum steady state error.

#### 4. Simulation Results

This section is divided into two subsections. The first subsection shows the results of the active and reactive current control using the conventional first order sliding mode control, and the second subsection shows the performance of the proposed integral SMC for control of the same state variables,  $I_{d-DG}$  and  $I_{q-DG}$ .

##### A. Active and Reactive Current Control Using Conventional SMC

The conventional first order SMC depends on the differential form for the sliding manifold as defined in (7), which leads to

$$S = \left(\lambda + \frac{d}{dt}\right)e = \lambda e + \frac{de}{dt} = \lambda(x_{ref} - x) + \frac{d}{dt}(x_{ref} - x) \quad (19)$$

$$= \lambda(x_{ref} - x) + \dot{x} = \lambda x_{ref} + (A - \lambda I)x + Bu + Fd$$

The condition of stability as given in (11) is applied on the state space equations (5), (6), and leads to

$$\dot{S}(x) = \frac{\partial S(x)}{\partial x} * \frac{\partial x}{\partial t} = \frac{\partial S(x)}{\partial x} * \dot{x} = (A - \lambda I)[Ax + Bu + Fd] \leq 0 \quad (20)$$

The control law is similar to the formula given in (16), where the first term is similar to the first term given in (17), while the second term is derived from (19) and (20) as,

$$u_{eq}(t) = [AB - \lambda IB]^{-1} [(AA - \lambda A)x + (AF - \lambda F)d] = 0 \quad (21)$$

The deduced control law is applied to the system defined in (5) and (6), and the tracking performance of the reactive and active currents,  $I_{d-DG}$  and  $I_{q-DG}$ , are shown in Fig. 2-a and Fig. 2-b, respectively.

It is noticed that the accurate tracking is achieved in some operating conditions such as  $I_{d-ref} = 400$  A and  $I_{q-ref} = 500$  A from time from 20 to 25 s. While in other operating conditions, the tracking may be lost, which leads to a large chattering and error as depicted at the operating condition for  $I_{q-ref} = 200$  A (injected) and  $I_{d-ref} = 400$  A (injected) for time from 30 to 35 s because when the differential term goes to zero, this does not guarantee that

the error is zero. This drawback will be alleviated with the presented integral SMC.

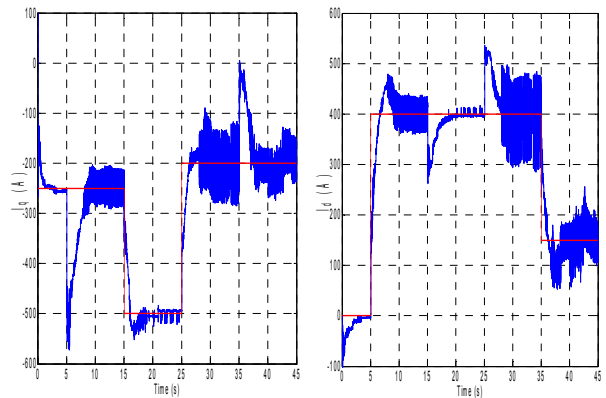

Fig. 2-a: Reactive current control using conventional SMC

Fig. 2-b: Active current control using conventional SMC

Fig. 2: Active and reactive current control using the conventional SMC

##### B. Active and Reactive Current Control Using Proposed Integral SMC

The active and reactive current control is the main function of any DGU in the DGS. Therefore, equations (16-18) are used to develop the control law that enables the system in (5), (6) to track the reference values,  $I_{d-ref}$  and  $I_{q-ref}$ . Fig. 3 shows the tracing performance of reactive and active currents with respect to their references as shown in Fig. 3-a and Fig. 3-b, respectively. It is clear from Fig. 3 that the tracking has been greatly improved compared to the performance of Fig. 2. Also, the dynamic performance is slightly enhanced since the settling time is also reduced compared to the performance of the conventional SMC. The voltage waveforms for this proposed integral SMC is also displayed to verify the power exchange between the DGS and the power grid.

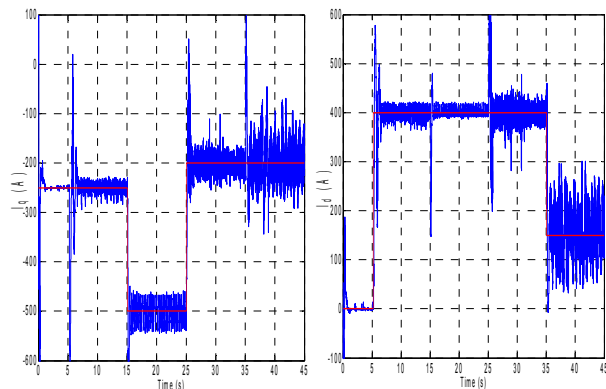

Fig. 3-a: Reactive current control using integral SMC

Fig. 3-b: Active current control using integral SMC

Fig. 3: Active and reactive current control using the proposed integral SMC

The system voltage and the DGU voltage are shown in Fig. 1-c for the operating condition as  $I_{q-ref} = 500$  A (injected) and  $I_{d-ref} = 400$  A (injected), where it shows the

DGU,  $E_{DG}$ , voltage leads and bigger than the system voltage,  $V_{sys}$ , that means the DGU injects active and reactive power to the system.

## 5. Conclusion

This paper presents an integral SMC to control the active and reactive currents for the distributed generation system. This paper clarifies the innovative formulation of the integral SMC that leads to better transient performance with less chattering compared to the conventional first order SMC. The presented simulation results prove that the active and reactive current can be precisely and independently controlled using the proposed technique. Consequently, the active and reactive power of the distributed generation system can be efficiency controlled based on the operating condition of distribution systems.

## References

- [1] G. Pepermansa, J. Driesenb, D. Haeseldonckxc, R. Belmansc, W. D'haeseleer, Distributed generation: definition, benefits and issues, *International Journal on Energy Policy*, Elsevier, vol. 33, 2005, pp. 787–798.
- [2] T. Ackermann, G. Andersson, L. Soder, 'Distributed generation: a definition, *International Journal of Electric Power System Research*, Elsevier, vol. 57, no. 3, April, 2001, pp. 195-204.
- [3] I. Colaka, E. Kabalcib, R. Bayindir, Review of multilevel voltage source inverter topologies and control schemes, *International Journal of Energy Conversion and Management*, Elsevier, vol. 52, no. 2, 2011, pp. 1114–1128.
- [4] M. N. Marwali, A. Keyhani, Control of distributed generation systems part I: voltages and currents control, *IEEE Trans on Power Electronics*, vol.19, no.6, 2004, pp-1541-1551.
- [5] L. Shang, J. Hu, Sliding-mode-based direct power control of grid-connected wind-turbine-driven doubly fed induction generators under unbalanced grid voltage conditions, *IEEE Trans on Energy Conversion*, vol. 27, no.2, 2012, pp. 362-374.
- [6] L. Xu, D. Zhi, L. Z. Yao, Direct power control of grid connected voltage source converters, *Proc. of IEEE Power Engineering Society General Meeting*, 2007, pp. 1-6.
- [7] T. Noguchi, H. Tomiki, S. Kondo, I. Takahashi, Direct power control of PWM converter without power-source voltage sensors, *IEEE Trans. on Industry Applications*, vol. 34, no. 3, 1998, pp. 473-480.
- [8] S. Rivera, S. Kouro, P. Cortés, S. Alepuz, M. Malinowski, B. Wu, J. Rodríguez, Generalized direct power control for grid connected multilevel converters, *Proc. International Conference on Industrial Technology*, 2010, pp. 1351-1358.
- [9] J. Hu, L. Shang, Y. He, Z. Q. Zhu, Direct active and reactive power regulation of grid-connected DC/AC converters using sliding mode control approach, *IEEE Trans on Power Electronics*, vol. 26, no.1, 2011, pp. 210-223.
- [10] J. Lian, Y. Zhao, G. M. Dimirovski, Integral sliding mode control for a class of uncertain switched nonlinear system, *European Journal of Control*, Elsevier, vol. 16, no. 1, 2010, pp. 16-22.
- [11] J. Rodríguez, J. Sheng Lai, F. Zheng Peng, Multilevel inverters: a survey of topologies, controls, and applications, *IEEE Trans. on Industrial Electronics*, vol. 49, no. 4, 2002, pp. 724-736.
- [12] J. Y. Hung, W. Gao, J. C. Jung, Variable structure control: a survey, *IEEE Trans. on Industrial Electronics*, vol. 40, no. 1, Feb. 1993, pp. 2-21.