

## FAULT INDICATORS EFFECTS ON DISTRIBUTION RELIABILITY INDICES

**H. FALAGHI**

Tarbiat Modarres University – Iran  
falaghi@modares.ac.ir

**M.-R. HAGHIFAM**

Tarbiat Modarres University – Iran  
haghifam@modares.ac.ir

**M. R. OSOULI TABRIZI**

Eastern Azarbayjan  
Electric Power Distribution Co. – Iran

### SUMMARY

*Reduction of failure rates and applying effective fault management can be affected in improvement of reliability indices in distribution systems. One of the ways to improving the reliability of distribution networks in fault management procedure is installing Fault Indicators (FIs) in overhead primary networks. FIs allow operators to quickly identify the location of a fault on overhead lines feeders. FIs can reduce fault localization and therefore reduction in outage duration and outage cost. In this paper, modelling of FIs in reliability assessment and computing of related indices such as SAIFI, SAIDI, CAIFI is introduced. Using model development and case studies it is discussed and shown that location and numbers of FIs effect in distribution reliability indices.*

**Keywords:** Distribution Systems, Fault Indicators, Reliability, Modelling.

### 1. INTRODUCTION

The basic function of an electric power system is to supply customer with acceptable degree of continuity and quality. Analysis of the customer failure statistics has shown that because radial configuration of feeders and high failure rates in equipments and feeder sections, distribution systems make the greatest contribution to the unavailability of power supply to customers [1].

There are only two main ways to improve the reliability of power distribution networks. The first one is to reduce the frequency of customers' interruptions and the second is to reduce the outage duration once the failure occurs [2- 4].

One of the ways to improving the reliability of distribution networks in fault management procedure is installing FIs in overhead primary networks. FIs allow operators to quickly identify the location of a fault on overhead lines feeders. Operators can then isolate the faulted section and begin necessary repairs and switching actions in minimum time. FIs can reduce fault localization and therefore reduction in outage duration and outage cost. They can be used in existing network with minimum cost and installing time. Also it can be used in systems with and also without distribution automation systems. However if they are equipped with sending signals to control center, the fault can be localized very quickly using GIS systems.

One of the tasks associated with the using of such devices is to evaluate quantitatively the effect of FIs on reliability of distribution systems for developing an effective method for optimal determining of numbers and locations of FIs.

In the past years, reliability modelling and assessment of distribution systems have received considerable attention, and

there are a number of publications dealing with the theoretical development and modelling methods.

In order to give more realistic modelling the effect of the FIs, the features associated with the fault management strategy need to be included in the reliability assessment.

In this paper, modeling of FIs in reliability assessment and computing of related indices such as SAIFI, SAIDI, CAIFI, ... is introduced [5]. It performs a number of sensitivity analyses of system reliability. Using model development and case studies it is discussed and shown that location and numbers of FIs effect in distribution reliability indices.

### 2. MODELLING AND EVALUATION TECHNIQUE

Following a fault occurrence on a feeder, faulted section of the network is identified and isolated, then the service is restored to un-faulted feeder sections and faulted section is repaired [6, 7]. This process is illustrated in Figure. 1.

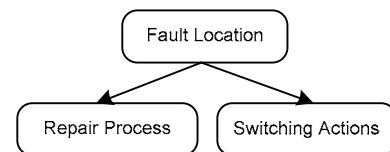

Figure 1- Actions after a fault occurrence

Existence of FIs can reduce the fault location time and consequently increase the system reliability. For example a typical feeder with a FI is shown in Figure. 2.

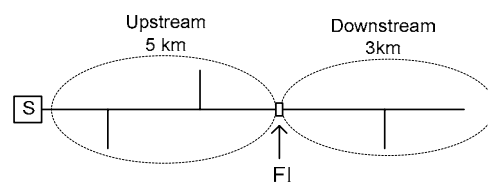

Figure 2- A Typical distribution system with one FI

Assume average fault location time of this feeder without FI is 0.75 hour. With installation of a FI, the fault location time for upstream part of the feeder is:

$$0.75 \times \frac{5}{3+5} = 0.46875 \text{ hour}$$

and for downstream part is:

$$0.75 \times \frac{3}{3+5} = 0.28125 \text{ hour}$$

In general, with installation of  $n$  FIs on a distribution feeder, that feeder is divided to  $n+1$  part and fault location time for  $i$ th part can be calculated as follow:

$$T_i = T_0 \left( \frac{L_i}{\sum_{j=1}^{n+1} L_j} \right) \quad i = 1, 2, 3, \dots, n+1$$

where,

$L_i$  : Length of part  $i$ th

$T_0$  : Average fault location time of feeder without FI

Therefore the effect of FIs on the reliability can be quantified using the following algorithm:

- (a) Consider each load point of the system.
- (b) Consider each failure mode of the load points.
- (c) Calculate average fault location time of the failure mode.
- (d) For each failure mode determine how service can be restored.
  - If service can only be restored by repair, choose the summation of fault location and repair time as restoration time.
  - If service can be restored by switching actions, choose the summation of fault location and switching time as restoration time.
- (e) Deduce load point indices by considering all the events leading to failure of the load point and their associated restoration procedure.
- (f) Assess the overall system indices by appropriately combining reliability indices of the load points.

### 3. IMPLEMENTATION

Based on the model and algorithm presented in this paper, a computer software package has been developed by Distribution Networks Laboratory in Tarbiat Modarres University, Tehran, Iran.

Our product takes a distribution network as an input, with all its connectivity and available data. The required data is:

- Physical connections between the different buses of distribution network
- Location of FIs, normally closed switches and tie points
- Failure rates and other reliability data of sections of feeders
- Load of buses

The required data is saved in the attribute tables of the

feeders. The software can directly access the values needed from the tables. For each part of the algorithm, a script was written for perform the analysis and computation required. The entire algorithm was therefore converted to a combination of scripts. The application run by calling a “main” script that acts as the “Supervisory” script. This script calls the needed scripts for a specific stage.

### 4. APPLICATION STUDIES

The test system is shown in Figure 2. This system is a real distribution network in Tehran utility/Iran. The network has 16 load points and the number of customers and average loads connected at each load point are shown in table 1. The reliability data are given in table 2. In the calculation the average fault location time is taken 0.75 hour.

Two cases are studied for investigation of number and location effects of the FIs on reliability indices.

*Case A-* For assessing of FIs locations on the reliability indices, 9 candidate locations are assumed as shown in figure 3 with Loc1 to Loc9. In this case, with changing of one FI location in each candidate point, effect of FI location in reliability indices are assessed using developed software. The results for this case are shown in figures 4 - 7. As shown in figure 4, FI location can not affected in SAIFI, but other indices such as CAIDI, SAIDI and ENS are strongly sensitive to the location of FI.

*Case B-* In this case effect of changing of installed FIs numbers in reliability indices is evaluated. In this case results for feeder without FI to installation of FIs in all of candidate locations are reported.

The results of this case are shown in figures 8-11. Results show that the rate of failure does not change, but with increasing of FIs numbers, distribution reliability indices (SAIDI, CAIDI and ENS) can be decreased. However, decreasing rates are not constant. Rates of reliability indices improvement approach to zero with installation of sufficient number of FIs in network. It is shown that for each feeder with a given configuration and failure rates and repair times we can find optimum number FIs with respect to economical aspects.

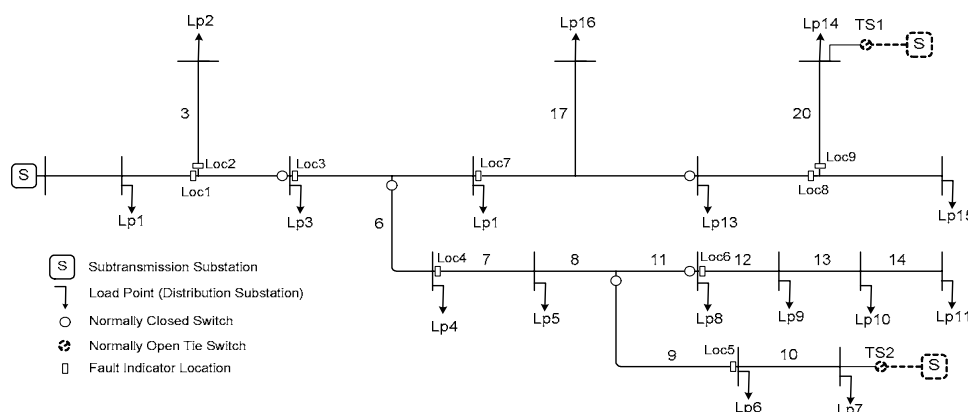

Figure 3- The real distribution system

TABLE 1- Reliability data for distribution feeder

Section Number	Length [km]	Failure Rate [f/yr.km]	Repair Time [h]	Switching Time [h]
1	0.42	1.49	1.5	0.5
2	0.25	1.49	1.5	0.5
3	0.294	1.49	1.5	0.5
4	0.411	1.49	1.5	0.5
5	0.190	1.49	1.5	0.5
6	0.190	1.49	1.5	0.5
7	0.340	1.49	1.5	0.5
8	0.110	1.49	1.5	0.5
9	0.124	1.49	1.5	0.5
10	0.030	1.49	1.5	0.5
11	0.124	1.49	1.5	0.5
12	0.200	1.49	1.5	0.5
13	0.140	1.49	1.5	0.5
14	0.104	1.49	1.5	0.5
15	0.167	1.49	1.5	0.5
16	0.189	1.49	1.5	0.5
17	0.033	1.49	1.5	0.5
18	0.138	1.49	1.5	0.5
19	0.481	1.49	1.5	0.5
20	0.200	1.49	1.5	0.5
21	0.290	1.49	1.5	0.5
Sum.	4.524	-	-	-

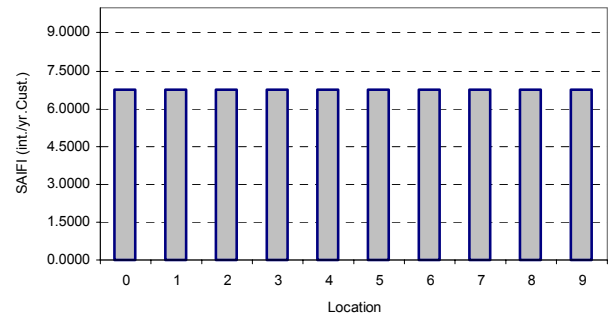

Figure 4- Variation of SAIFI in case A

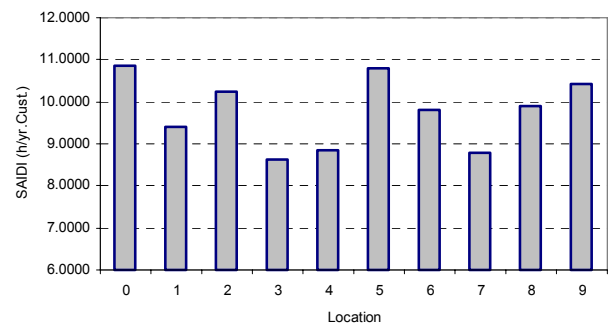

Figure 5- Variation of SAIDI in case A

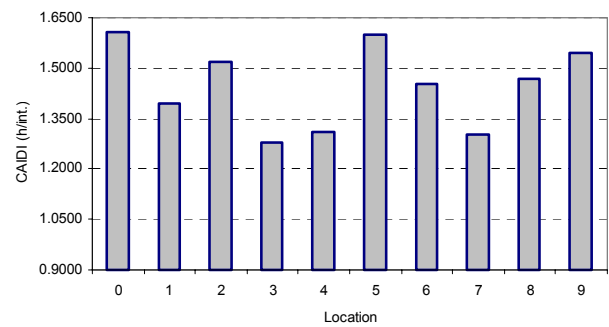

Figure 6- Variation of CAIDI in case A

TABLE 2- Load data for distribution feeder

Load Point Number	Average Load [kW]	Number of Customer
1	90	137
2	100.1	126
3	18.7	20
4	90	284
5	269.5	210
6	50.6	57
7	87.6	135
8	90	172
9	85	170
10	200	190
11	51.04	56
12	26.4	38
13	16.5	10
14	374	280
15	90	204
16	45.1	49
Sum.	1684.54	2138

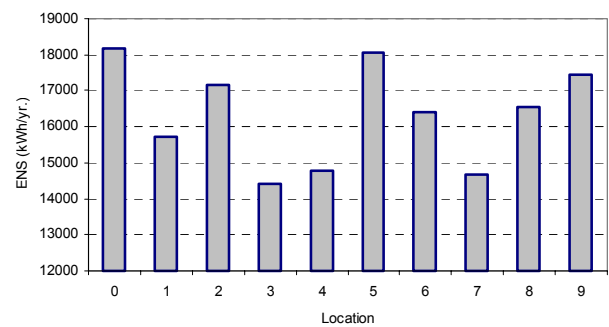

Figure 7- The Variation of ENS in case A

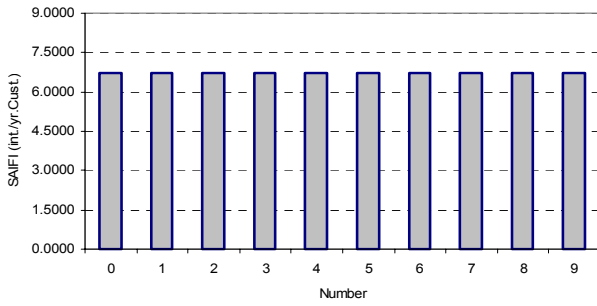

Figure 8- Variation of SAIFI in case B

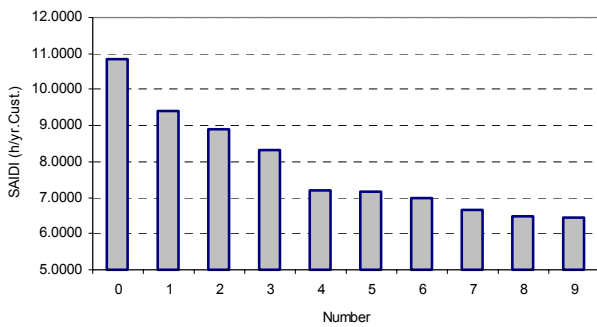

Figure 9- Variation of SAIDI in case B

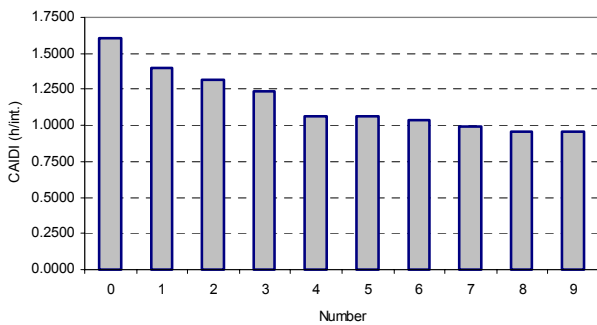

Figure 10- Variation of CAIDI in case B

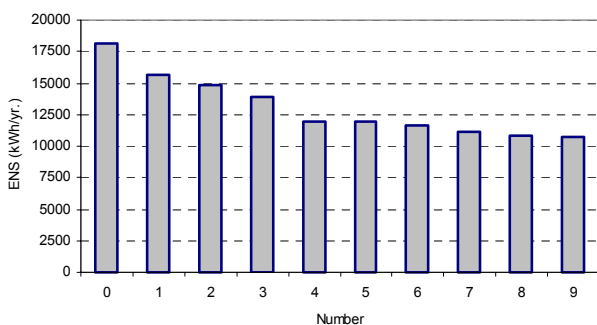

Figure 11- Variation of ENS in case B

5. CONCLUSION

This paper has examined the impact of FIs on reliability of distribution systems. It has described the model and techniques needed to evaluate reliability of distribution systems with FIs. The proposed model has been applied to a real Iranian distribution network.

The analysis shows that the reliability indices are highly sensitive to locations of FIs. The reliability indices can be enhanced monotonically as number of FIs increased. It also shows that the benefits obtained from FIs installation tend to asymptotes to limiting values when sufficient number of these devices has been added. Developing a complete economical modelling and using optimization methods such as genetic algorithm for problem solving in large scale distribution systems are under study and will be reported in further works.

6. REFERENCES

- [1] R. Billinton, R. N. Allan, 1996, Reliability Evaluation of Power Systems, Plenum Press, New York, USA.
- [2] R. Billinton and S. Jonnavithula, "Optimal Switching Device Placement in Radial Distribution System", IEEE Transaction on Power Delivery, Vol.11, No.3, pp. 1646-1651, July 1996.
- [3] Ying. He, G. Anderson, and R. N. Allan, 1999, "Determining Optimum Location and Number of Automatic Switching Devices in Distribution Systems", Proceedings of the IEEE Power Tech'99 Conference, Budapest, Hungary.
- [4] R. E. Brown, "Electric Power Distribution Reliability", Marcel Dekker, Inc, New York, Basel, 2002.
- [5] IEEE Standard 1366-1998, IEEE trial-use guide for electric power distribution reliability Index, 1998.
- [6] M.-R. Haghifam, H. Falaghi, M. Ramezani, 2003, "Enhancement in distribution systems using optimal allocation of switching devices", CIRED 2003 Conference, Session 5, Paper No. 51, Spain.
- [7] H. Falaghi, M.-R. Haghifam, "Simultaneous Allocation of Sectionalizers and Tie Points in Electric Distribution Systems", Accepted for publication in International Journal of Power and Energy Systems.