

# Effects of Voltage-Sensitive Dye di-4-ANEPPS on Isolated Rat Heart Electrogram

Kateřina Fialová<sup>1</sup>, Jana Kolářová<sup>2</sup>, Oto Janoušek<sup>2</sup>, Marina Ronzhina<sup>2</sup>, Ivo Provazník<sup>2</sup>, Marie Nováková<sup>1</sup>

<sup>1</sup> Department of Physiology, Faculty of Medicine, Masaryk University, Brno, Czech Republic  
<sup>2</sup> Department of Biomedical Engineering, Faculty of Electrical Engineering and Communication, University of Technology, Brno, Czech Republic

## Abstract

*Mapping of cardiac electrical activity from Langendorff-perfused hearts using the voltage-sensitive dye (VSD) di-4-ANEPPS has yielded important new information. However, data about response of the heart to staining with VSD are scarce. Voltage-sensitive dye di-4-ANEPPS is currently used in our laboratory for recording of monophasic action potentials by optical method in isolated hearts. The most often used species in basic cardiology is the rat heart.*

*In order to describe in more detail the response of the heart tissue exposed to di-4-ANEPPS, heart rate changes and arrhythmia-preceding parameters in isolated rat heart electrogram during staining with di-4-ANEPPS and washout period, were followed.*

## 1. Introduction

Mapping of cardiac electrical activity employing the voltage-sensitive dyes (VSDs) represents one of new and promising methods in basic cardiology laboratories. The electrical changes on the membrane either of one cardiomyocyte or from small area on the surface of the heart can be recorded. This approach is now considered as a valuable tool for electrophysiological studies focused on numerous, frequently studied topics in cardiovascular system physiology and pathophysiology, such as ischemia, reperfusion, arrhythmias triggering, preconditioning, postconditioning, etc.

Voltage-sensitive dyes undergo changes in their electronic structure, and as a consequence also in their fluorescence spectra. These changes result from changes in the surrounding electric field, in excitable tissues such as myocardium or neurons. Therefore, VSD may be used successfully for recording of monophasic action potentials (MAPs) in such models. Various VSDs have been introduced into everyday laboratory practice (merocyanine, ANEPPS, etc.). Dyes from ANEPPS group (amino-naphthyl-ethenyl-pyridinium) are the most frequently used in cardiac preparations [1,2]. One of

them, di-4-aminonaphthyl-ethenyl-pyridinium (di-4-ANEPPS) is utilized in our laboratory for recording of MAPs by optical method in the well established model of isolated heart of various animal species.

In our previous papers [3], electrophysiological effects of VSD di-4-ANEPPS in guinea pig and rabbit isolated hearts were summarized. In the present paper, most often employed experimental model in basic cardiology laboratories - rat isolated heart perfused according to Langendorff - is studied. In order to determine the response of 2  $\mu$ M di-4-ANEPPS, heart rate changes and arrhythmia-preceding parameters – QRS duration, QT and QT<sub>c</sub> – were followed.

## 2. Methods

In this study, five adult male Wistar rats (average body mass 322.4  $\pm$  29.49 g) were included. Each experiment consisted of five phases: isolation of the heart, control perfusion, loading with the dye (staining), washout period, and MAPs recording under control conditions (37°C, spontaneously beating heart).

In brief, the animals were deeply anaesthetised by inhalation of ether. After subsequent cervical dislocation, the chest was quickly opened and the heart excised with a sufficiently long segment of ascending aorta.

After the heart isolation, the heart was firmly fixed to perfusion set-up by the stump of aorta and then placed in thermostat-controlled bath (37°C) filled with Krebs-Henseleit (K-H) solution of following composition (in mM): NaCl 118, NaHCO<sub>3</sub> 24, KCl 4.2, KH<sub>2</sub>PO<sub>4</sub> 1.2, MgCl<sub>2</sub> 1.2, glucose 5.5, Taurine 10, and CaCl<sub>2</sub> 1.2. The solution was continuously oxygenated with 95% O<sub>2</sub> and 5% CO<sub>2</sub>. The heart was then perfused with the same solution at the constant perfusion pressure (80 mmHg) for 25 - 30 minutes – control period. The perfusion was performed on Langendorff apparatus modified previously in our laboratory [4]. All hearts exhibiting any dysrhythmias during control period were discarded. Next, the tissue was stained with 2  $\mu$ M di-4-ANEPPS (Molecular Probes, Eugene, OR, USA) applied via

coronary arteries (stock solution 2 mM diluted by perfusion solution up to final concentration of 2  $\mu$ M). This period lasted 20-25 min on average (depending on coronary flow). Then the hearts were perfused with dye-free K-H solution (20-25 min, washout period). After the excess of VSD was washed out, exposure to light source and recording of MAPs started.

MAPs were recorded by the optical system [5]. It consists of a flexible bifurcated fibre cable with seven optical fibres (six illuminations fibres positioned in a circle and a detection fibre positioned in the centre of the cable). The fibre optics together with micromanipulator in the bath of perfusion system enables the user to scan action potentials from various places on the heart surface with almost no mechanical constraint. The optical probe is softly attached to the preparation to suppress motion artefacts without a need of focusing. The motion artefacts are diminished by slight restriction of the preparation by plastic circle placed around the heart.

The "input" end of the cable with six illumination fibres is connected to a light source. The "output" (detection) fibre is connected to a light detector that senses the beam of emitted light. The optical fibres are protected by a silicon inner tube and a flexible chrome plated brass outer tubing. The tubing also gives stress relieve.

The changes in dynamics of transmembrane potential result in amplitude modulation of the emitted light. This is detected by a photodiode detector with a high-pass (>610 nm) filter. The output signal of the photodiode detector is pre-amplified so that the two stage amplifier adjusts the signal to input range of data acquisition card ( $\pm 1$  V). The electrical circuits include also an analogue anti-aliasing filter (low-pass filter  $f_c=2$  kHz) and a high-pass filter ( $f_c=0.05$  Hz) to suppress DC offset.

The data acquisition card processes the pre-amplified and filtered signal. The card digitizes the signal with 12 bits dynamic range and at rate of 4000 samples/sec. The digital signal is stored on a hard disk for further off-line processing (noise suppression, visualization and analysis). Data acquisition is controlled by subroutines of a software package LabView.

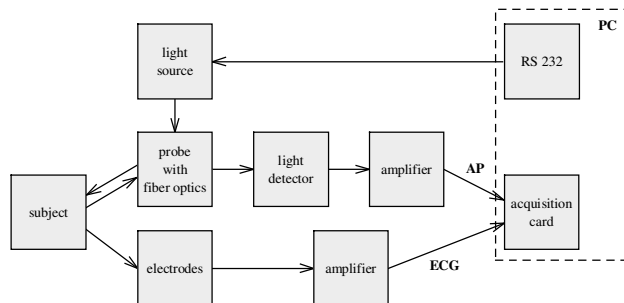

Figure 1. The block diagram of the acquisition system.

During the whole experiment, including staining and washout periods, touch-less electrogram was recorded from three orthogonal bipolar leads (X, Y, and Z) [6]. Six silver-silver chloride disc electrodes (4 mm in diameter) were placed on the inner surface of the bath in which the heart was placed during the experiment. The signals were amplified by a set of three biological amplifiers DAM50 (World Precision Instruments, USA) and further simultaneously digitized by 16-bit AD converters at a sampling rate of 2000 samples/sec using a data acquisition multifunction card PCI-6250 (National Instruments, USA). The digital signals are stored on a hard disc for further off-line processing.

An example of synchronous recording of electrogram and MAPs is given in Figure 2.

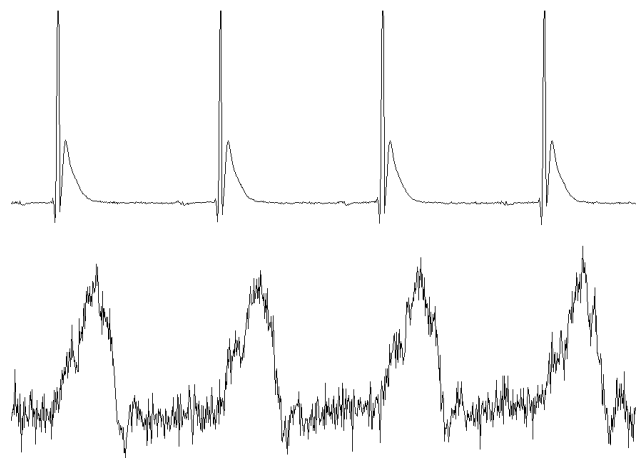

Figure 2. Synchronous recording of electrogram by touch-free method (top, one bipolar lead) and corresponding MAPs by optical method (bottom) from isolated rat heart perfused according to Langendorff. Recording at control conditions (37°C, spontaneously beating heart), unfiltered signal.

The recorded electrograms were analysed and the heart rate (HR) changes were evaluated from manually measured and averaged ten RR intervals at the end of each fifth minute during both – staining and washout – periods. The results were then normalized to the end of control period (100%). Off-line analysis also comprises assessment of QT interval, QRS complex duration, and rate-corrected QT interval ( $QT_c$ ), which were also normalized to the end of control period.

The incidence of arrhythmias was noted, especially their severity, timing and frequency of appearance. Each examined heart was given a score from 0 to 5 according to Lambeth convention [7]. Lambeth score classifies the heart according to the most severe kind of arrhythmia appearing during the particular part of experiment (0 – no arrhythmia, 1 – single premature ventricular complexes [PVCs], 2 – salvos, 3 – ventricular tachycardia, 4 –

reversible ventricular fibrillation, 5 – sustained ventricular fibrillation, lasting more than 2 minutes).

### 3. Results

Perfusion of the isolated rat hearts with VSD di-4-ANEPPS caused specific changes of electrograms in all examined hearts. Only moderate arrhythmias were observed, mainly AV-blockades and single ventricular extrasystoles during staining. During washout, all arrhythmias completely disappeared. Two hearts reached score 1 during staining; during washout, all hearts were classified by score 0.

Normalized RR interval lengthened at the beginning of staining in all studied hearts. It then gradually shortened and partially, but significantly restored during washout (see Fig. 3).

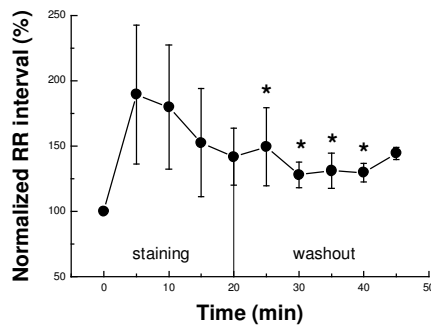

Figure 3. Normalized RR intervals during staining and washout periods in rat isolated hearts. \* significant at  $p < 0.05$  vs. end of control.

QT intervals did not change during the whole experiment.  $QT_c$  intervals slightly, insignificantly prolonged during staining; a recovery to control values was observed in washout phase (see Fig. 4).

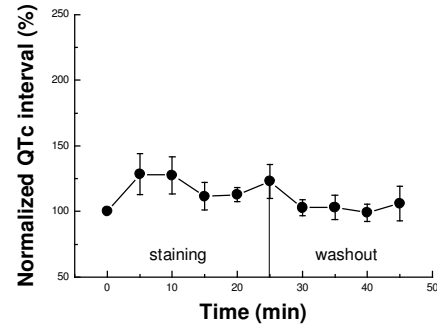
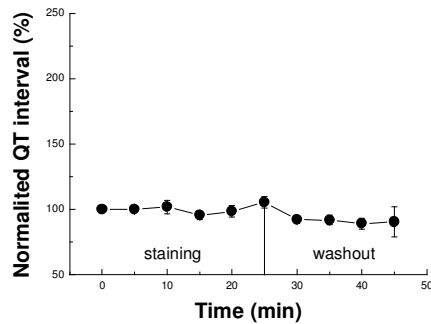

Figure 4. Normalized QT interval (top) and  $QT_c$  interval (bottom) during staining and washout periods in rat isolated hearts.

The width of QRS complex increased during staining and this prolongation persisted till the end of washout period (see Fig. 5).

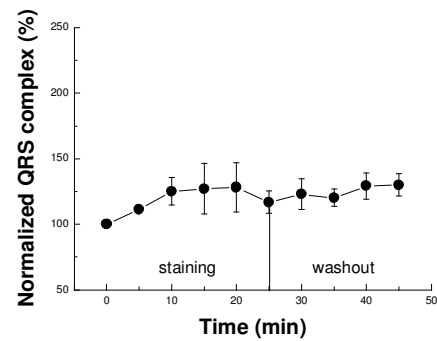

Figure 5. Normalized QRS complex duration during staining and washout periods in rat isolated hearts.

### 4. Discussion and conclusions

Mapping of the electric field using voltage-sensitive dyes represents the possibility of obtaining very high spatial resolution without damaging the heart tissue e.g. when classical suction electrodes are employed. This approach may be with advantage applied for recordings in small preparations or small areas, such as the hearts of rodents. Namely, the rat heart is a widely used model in cardiac electrophysiological studies.

Since the introduction of this method in 1968, it has been improved markedly and numerous VSDs from various chemical groups have been tested. Most prominent pharmacological effect of VSDs on cardiac tissue is so-called photodynamic or phototoxic damage. Formation of free radicals or direct interaction with the voltage-gated calcium and/or potassium channels has been suggested as explanation of this adverse effect. As a result, altered conductivity and the time-dependent gating of ionic specific channels is observed [8].

The effects of 1  $\mu\text{M}$  di-4-ANEPPS on the rat isolated heart were characterized as changes of RR interval (heart rate), QT interval, QT<sub>c</sub> interval, QRS complex, and arrhythmias incidence. Perfusion with di-4-ANEPPS resulted in brief episodes of AV blockades. In those hearts, a prolongation of the PQ interval was observed, too. The PQ interval prolongation was found to be strictly due to di-4-ANEPPS because it was not observed in hearts perfused with solvent (0.01% DMSO) alone [9]. The mechanism by which di-4-ANEPPS affects the PQ interval in the rat heart remains unexplained. One possibility is affection of the intracardiac ganglia present in the rat AV junction by the dye which results in local release of acetylcholine at the AV node and thus prolongs the PQ interval. Another putative explanation is that the dye changes (decreases) perfusion of the AV node and thus brings about its ischemia. However, no global signs of ischemia (arrhythmias, ST segment elevation, etc.) and no increase in perfusion pressure were observed in these experiments. In fact, di-4-ANEPPS caused a transient decrease in perfusion pressure. Thus, the most plausible explanation is that di-4-ANEPPS affects either ion channels or intercellular coupling (connexins) in the AV node, resulting in slowed conduction.

In our previous study [8] on the effects of loading of guinea pig and rabbit isolated hearts with 2  $\mu\text{M}$  di-4-ANEPPS, slowing of the heart rate and partial blocks in AV node were observed. Accompanying changes of the shape of electrogram curve favored the idea of direct effect of the dye on cardiac ionic channels – and because the shape and amplitude of T wave was often impaired during the loading and washout periods, we concluded that predominantly potassium channels were affected in these two biomodels.

In the present experiments, the normalized RR intervals of isolated rat hearts showed tendency to lengthen during the staining and partially recovered throughout washout period. As mentioned above, di-4-ANEPPS affects either ion channels or intercellular coupling in the AV node, thus resulting in slowed conduction. Similar effect might be expected in SA node and it might explain heart rate changes in this experimental setup. QT intervals did not change during the whole experiment. QT<sub>c</sub> intervals slightly, insignificantly prolonged during staining and recovery to control values was observed in washout phase. The noticed arrhythmias in the studied biomodel were only of moderate type and were present only in minority of the studied hearts. In summary, the observed effects of di-4-ANEPPS on electrogram of rat isolated hearts are of minor character.

Although the procedure of staining with the dye affects electrophysiological properties of the myocardium, these changes were mostly insignificant and reversible in rat isolated hearts. Thus, it may be concluded that using VSD di-4-ANEPPS for optical recording of MAPs in rat

isolated hearts is reasonably safe and without remarkable side-effects on myocardium itself and its electrophysiological properties.

## Acknowledgements

All experiments followed the guidelines for animal treatment approved by local authorities and conformed to the EU law.

This work was supported by the grant projects of the Grant Agency GACR 102/07/1473 and MSM 0021622402.

## References

- [1] Loew LM. Potentiometric dyes: Imaging electrical activity of cell membrane. *Pure Appl. Chem.* 1996;68:1405–9.
- [2] Salama G. Optical mapping: background and historical perspective. In: Rosenbaum DS. And Jalife J. *Optical Mapping of Cardiac Excitation and Arrhythmias* 2001. Futura Publishing Company, Inc. Chapter 1:9-31.
- [3] Fialova K, Kolarova J, Provaznik I, Novakova M. Comparison of Voltage-Sensitive Dye di-4-ANEPPS Effects in Isolated Hearts of Rat, Guinea Pig, and Rabbit. *Computers in Cardiology* 2010. Belfast: IEEE, 2010;37,565-568.
- [4] Novakova M, Moudr J, Braveny P. A modified perfusion system for pharmacological studies in isolated hearts. In: *Analysis of Biomedical Signals and Images. Biosignal* 2000. Brno: Vutium Press, 2000;162-4.
- [5] Provaznik I, Novakova M, Vesely Z, Blaha M, Chmelar M. Electro-optical recording system for myocardial ischemia studies in animal experiments. *Computers in Cardiology* 2003. Boston: IEEE, 2003;30:573–6.
- [6] Uematsu T, Vozeh S, Ha HR, Follath F, Nakashima M. Method for stable measurement of the electrocardiogram in isolated guinea pig heart. *J. Pharmacol. Methods* 1987;18: 179–185.
- [7] Walker MJA, Curtis MJ, Hearse DJ, Campbell RWF, Janse MJ, Yellon DM, et al. The Lambeth Conventions: guidelines for the study of arrhythmias in ischaemia, infarction, and reperfusion. *Cardiovasc Res* 1988;22:447-455.
- [8] Novakova M, Bardonova J, Provaznik I, Taborska E, Bochorakova H, Paulova H, Horky D. Effect of voltage sensitive dye di-4-ANEPPS on guinea pig and rabbit myocardium. *Gen Physiol Biophys* 2008;27:45-54.
- [9] Nygren A, Kondo C, Clark RB, Giles WR. Voltage-sensitive dye mapping in Langendorff-perfused rat hearts. *Am J Physiol Heart Circ Physiol* 2003;283:H892-902.

Address for correspondence.

Kateřina Fialova  
Department of Physiology  
Faculty of Medicine, Masaryk University  
Kamenice 5  
625 00, Brno  
Czech Republic  
[katy.fialova@email.cz](mailto:katy.fialova@email.cz)