



ISSN: 2319-8753

## International Journal of Innovative Research in Science, Engineering and Technology

(An ISO 3297: 2007 Certified Organization)

Vol. 3, Issue 2, February 2014

# Talking Assistance about Location Finding both Indoor and Outdoor for Blind People

Nandhini.N<sup>1</sup>, Vinoth chakkaravarthy.G<sup>2</sup>, G.Deepa Priya<sup>3</sup>

P.G. Student, Department of Computer Engineering, Velammal College Of Engineering and Technology, Madurai,  
Tamil Nadu ,India<sup>1</sup>

Associate Professor, Department of Computer Engineering, Velammal College Of Engineering and Technology,  
Madurai, Tamil Nadu, India<sup>2</sup>

P.G. Student, Department of Computer Engineering, Velammal College Of Engineering and Technology, Madurai,  
Tamil Nadu ,India<sup>1</sup>

**Abstract:** God gifted sense to human being which is an important aspect in our life is vision. We are able to see the beauty of nature, things which happen in day-to-day life with the help of our eyes. But there are some people who lack this ability of visualizing these things. They face many difficulties to move on with their daily life. The problem gets worse when they move to an unfamiliar location. Visually impaired people face many challenges when moving in unfamiliar public places. Only few of the navigation systems for visually impaired people can provide dynamic interactions. None of these systems work perfectly both indoors and outdoors. Current navigation device for the visually impaired focus on travelling from one location to another. This focuses on designing a device for visually impaired people that help them to travelling independently also it must be comfortable to use. The proposed device is used for guiding individuals who are blind or partially sighted. The device is used to help blind people to move with the same ease and confidence as a sighted people. The device is linked with a GPS to identify the location of the blind person. Moreover, it provides the voice alert to avoid obstacles based on ultrasonic sensors. An emergency button is also added to the system. A RFID can be installed into public building and it is also integrated into blind persons walking stick .The whole device is designed to be small and is used in conjunction with the white cane.

**Keywords:** RFID,GPS,GSM,sonar sensor

### I.INTRODUCTION

Blindness or visual impairment is a condition that affects many people around the world. This condition leads to the loss of the valuable sense of vision. Worldwide more than 160 million people are visually impaired with 37 million to be blind. The need to for assistive devices was and will be continuous. There is a wide range of navigation systems and tools existing for visually impaired individuals. The blind person truly requirements and identifying objects.

#### A. Background

There are 285 million people worldwide that have some level of visual impairment. The blind navigation system catering needs of the blind people who are not able to move from one place to other place without the help of others. Recent survey source India is now become the world's large number of blind people. There are 37 million blind people across the globe, over them 15 million people are from India. The usage of the blind navigation system is very less and not efficiently used for Indian environment. The blind traveller should depend on any other guide like blind cane, people information, trained dogs, etc. Visual function can be classified by four tiers: normal vision, moderate visual impairment, severe impairment, and complete blindness. Legally blind refers to a person who has less than 20/200 vision in either eye, or a limited field of vision. Many virtually impaired people use walking sticks and guide dogs to move from place to place.For this group of population; the goal is often to complete tasks in the least obstructive method. A guide dog is trained to guide its users to avoid the accidents from objects and barriers. When a visually

# International Journal of Innovative Research in Science, Engineering and Technology

(An ISO 3297: 2007 Certified Organization)

Vol. 3, Issue 2, February 2014

impaired person is using a walking stick, they waving their walking stick and finds the obstacle by striking obstacles ahead of them.

## **B. Motivation**

God gifted sense to human being which is an important aspect in our life is vision. We are able to see the beauty of nature, things which happen in day-to-day life with the help of our eyes. But there are some people who lack this ability of visualizing these things. They face many difficulties to move on with their daily life. The problem gets worse when they move to an unfamiliar location. Visually impaired people face many challenges when moving in unfamiliar public places. Hence a system has to be found to minimize the difficulties of virtually impaired people to reach their destination. Studies indicate that there are approximately 10 to 11 million blind and visually impaired people in North America, and this number is growing at an alarming rate. As many of these people have difficulty knowing where they are or where they are going, frequently feeling totally disorientated or even isolated, supplemental navigational guidance is very important for them. Navigation involves updating one's position and orientation while he or she is travelling an intended route, and in the event the person becomes lost, reorienting and re-establishing a route to the destination.

## **C. Objective**

The paper main objective is to provide a talkative assistance to blind people. We are going to develop a intelligent system that works efficiently good in both indoor and outdoor. Current navigation device for the visually impaired focus on travelling from one location to another. This focuses on designing a device for visually impaired people that help them to travelling independently also it must be comfortable to use. The proposed device is used for guiding individuals who are blind or partially sighted. The device is used to help blind people to move with the same ease and confidence as a sighted people. The device is linked with a GPS to identify the location of the blind person. Moreover, it provides the voice alert to avoid obstacles based on ultrasonic sensors. An emergency button is also added to the system. A RFID can be installed into public building and it is also integrated into blind persons walking stick .The whole device is designed to be small and is used in conjunction with the white cane.

## **D. Scope of the paper**

The scope of this system is to develop a low-cost system that assist the blind and visually impaired without the help of sighted person. The system is a GSM-GPS based so that it takes the advantages of the GSM network such as the popularity and cost-effectiveness. Additionally, GSM-GPS module have been used in different areas of human activity, such as the navigation of vehicles and navigation aids to guide visually impaired pedestrian and let them to avoid obstacles and reach their destination. RFID is used in indoor to assist the blind people since GPS cannot be used efficiently in indoor. Also we use GSM to send a alert message to the authorized person.

## **E. Problem definition**

The population of India has reached 120 Cr. Of those 8.90 Cr people are visually impaired.90% of those can't walk independently [1]. 7% of them make the use of guide cane and remaining 3%of them make the use of guide dog [1]. But a guide dog would also be a burden for them as they can move only to the places that dog is trained. Our paper mainly focuses on the visually impaired people who cannot walk independently in unfamiliar environment. The main aim of our paper is to develop a system that helps the blind people to move independently in the unfamiliar environment.

# International Journal of Innovative Research in Science, Engineering and Technology

(An ISO 3297: 2007 Certified Organization)

Vol. 3, Issue 2, February 2014

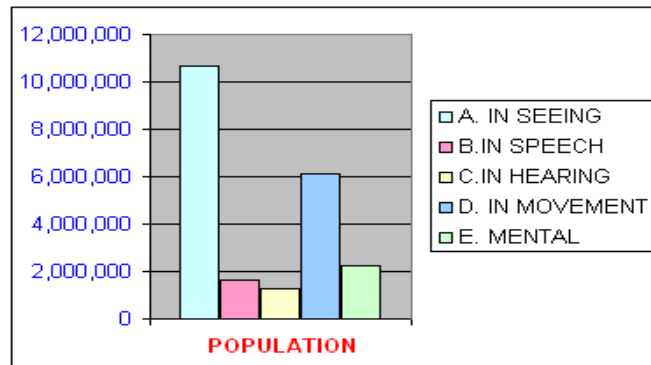

Fig 1: Statistical analysis

## II. LITERATURE SURVEY

There are several methods and devices used to guide visually impaired persons. Several research works are being performed by many institutions throughout the world to offer the best navigational robot in terms of cost effectiveness. This section gives a brief review on various navigational aids for blind individuals.

### A. Literature Survey

Blind and visually impaired people are at a disadvantage when they travel because they do not receive enough information about their location and orientation with respect to traffic and obstacles on the way and things that can easily be seen by people without visual disabilities. The conventional ways of guide dog and long cane only help to avoid obstacles, not to know what they are. Navigation systems usually consist of three parts to help people travel with a greater degree of psychological comfort and independence: sensing the immediate environment for obstacles and hazards, providing information about location and orientation during travel.

Today in the market different technologies like GPS, GPRS, etc are used to navigate visually impaired people. The studies of various published international papers have been done. Before more technologically advanced solutions to mobility aids are discussed it is useful to outline basic properties of the traditionally used primary aids and explain their main properties and limitations.

**1) White can:** The most popular mobility hand held aid. It is usually foldable and adjustable to the height of the user. A blind person using swing-like movements, “scan” the path in front in approx. 1 m distance (near-space protection). The cane requires about 100 hours of training for skilful use, e.g. detecting drop-offs, walking up and down the stairs. *Advantages:* cheap, light-weight constructions available, effectively informs of shorelines, landmarks and obstacles at ground-level, notifies others about visual disability of its user. *Disadvantages:* does not protect from obstacles at torso and face level

**2) Guidance of dog:** A specially trained dog assisting the blind in obstacle avoidance, but usually not aiding in way finding (unless travelling a familiar path), e.g. the dog is trained to stop before obstacles, reacts to commands on walking directions. In spite of their great usefulness, guide dogs are a rarely used aid - only about 1% of the visually impaired use it. Most guide dog owners do not simultaneously use the dog and the white cane.

*Advantages:* good in following familiar paths, good overall obstacle avoidance, trained for selective disobedience when sensing danger to his owner.

*Disadvantages:* very costly (training cost approx. \$40k in the USA), guide dog service period is on average 6 years, regular dog up-keeping costs and lifestyle changes.

**3) Human guide:** A blind person walks hand in hand with a sighted guide.

*Advantages/disadvantages:* The most obvious, but in practice not a permanent solution for aiding the blind in mobility and navigation. A blind person lacks privacy and can have a feeling of being a burden to his or her guide.

4) **Navbelt:** The Navbelt consists of a belt, a portable computer, and an array of ultrasonic sensors mounted on the front of the belt. The user wears a “fanny pack” on the abdomen and a portable computer as a backpack. Eight ultrasonic sensors, each covering a sector of 15°, are mounted on the front pack, providing a total scan of 120°. The computer processes the signals that arrive from the sensors, and applies in the robotics obstacle avoidance algorithms.

**III. BLOCK DIAGRAM**

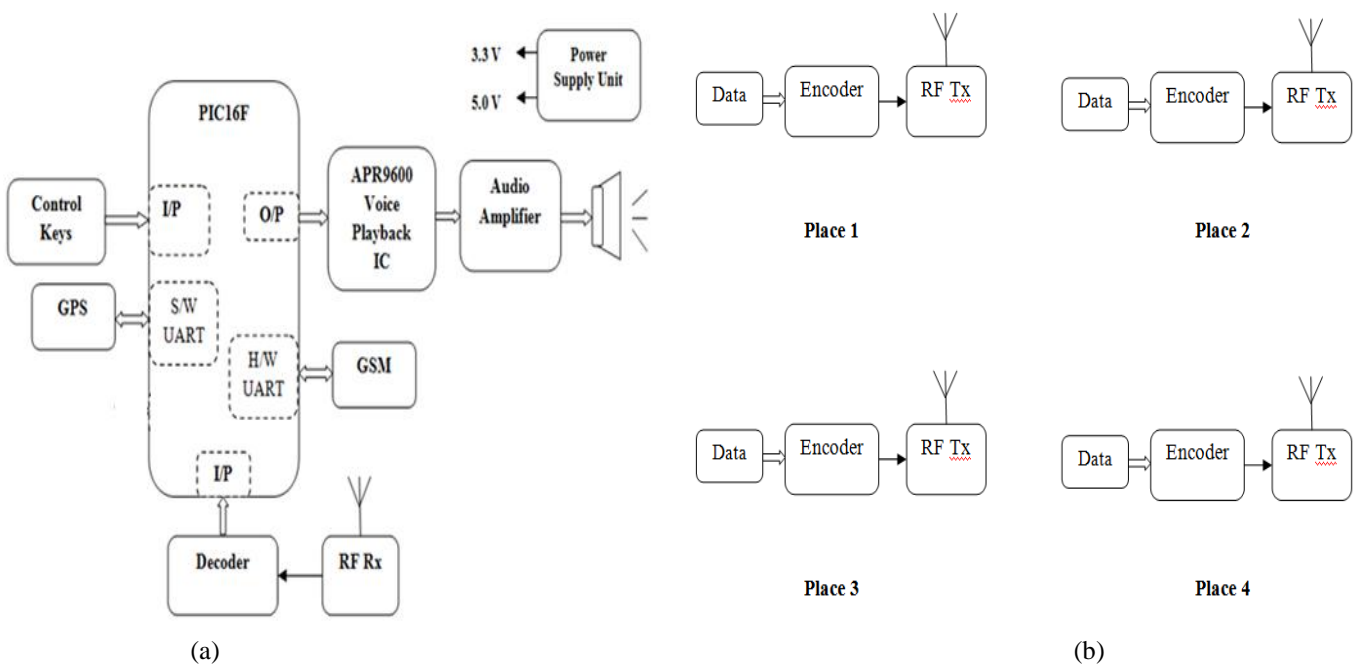

Fig 2 (a) Block diagram for the walking stick unit (b) Block diagram of the sign unit that is placed indoor at different places

**IV. SYSTEM DESCRIPTION**

The Fig 2(a) shows the block diagram of the walking stick unit that is present in the walking stick of the blind people. The walking stick unit consist of the GPS that is used to help the VIP to know information about the location in the outdoor location. It also consists of GSM to send message to authorized people at the time of emergency. The control key helps to switch to different modes. Finally the system has a RF receiver to read the information from the RF transmitter.

The proposed system architecture works as following, the RFID is used for indoor location detection and GPS is used for the location detection in outdoor.

In indoor the RFID is attached to the walking unit and an RFID tag is installed on all the areas that need to be identified. These tags will serve as a landmark to the person using the cane. Every tag will be equipped with as much information as needed to clearly define the location of that precise tag (i.e. restaurant, shops). The tag will also incorporate additional information concerning direction and locations of other sensitive location (i.e. Bus station, subway station and phone boots). The tag will be covered by a protective shield to keep it safe from any harm. The cane used in this system is the one currently available in its specific market and that is commonly used by the visually

In outdoor we use the help of GPS to find the location of the particular place. The GPS which is attached to the walking stick will help to locate the place in outdoor. Thus we reduce the expense of installing to many RFID in outdoor to identify the place.

**IV DATA FLOW DIAGRAM**

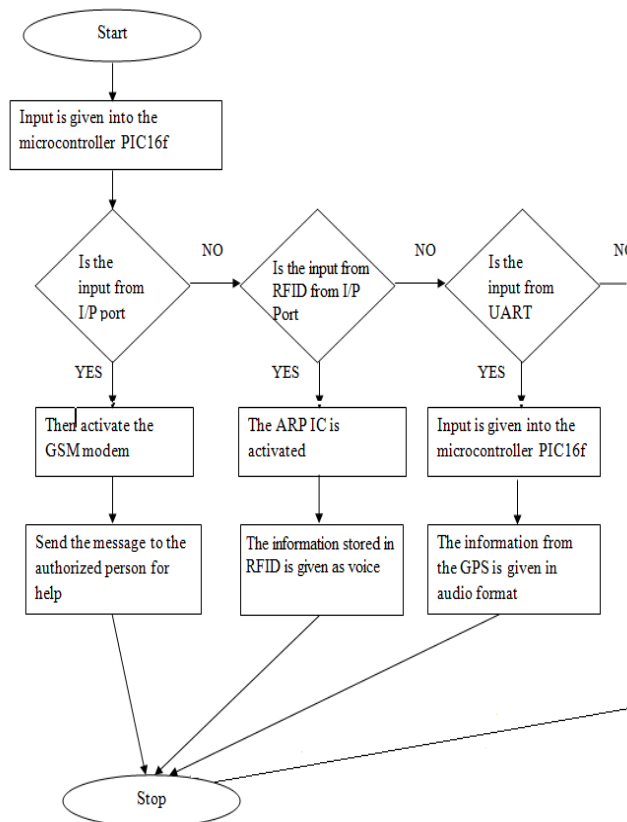

Fig 3 Data Flow diagram of the walking stick unit

**V. SYSTEM ANALYSIS**

**A. MICROCONTROLLER**

Microcontroller PIC16F877A is one of the PIC Micro Family microcontroller which is popular at this moment, start from beginner until all professionals. Because very easy using PIC16F877A and use FLASH memory technology so that can be write-erase until thousand times. The superiority this RISC Microcontroller compared to with other microcontroller 8-bit especially at a speed of and his code compression. PIC16F877A have 40 pin by 33 path of I/O. PIC 16F877 is a 40-pin 8-Bit CMOS FLASH Microcontroller from Microchip. The core architecture is high-performance RISC CPU with only 35 single word Instructions. Since it follows the RISC architecture, all single cycle instructions take only one instruction cycle except for program branches which take two cycles. 16F877 comes with 3 operating speeds with 4, 8, or 20 MHz clock input. Since each instruction cycle takes four operating clock cycles, each instruction takes 0.2 μs when 20MHz oscillator is used. It has two types of internal memories: program memory and data memory. Program memory is provided by 8K words (or 8K\*14 bits) of FLASH Memory, and data memory has two sources. One type of data memory is a 368-byte RAM (random access memory) and the other is 256-byte EEPROM (Electrically erasable programmable ROM). The core feature includes interrupt capability up to 14 sources, power saving SLEEP mode, and single 5V In-Circuit Serial Programming (ICSP) capability. The sink/source current, which indicates a driving power from I/O port, is high with 25mA. Power consumption is less than 2 mA in 5V operating condition.

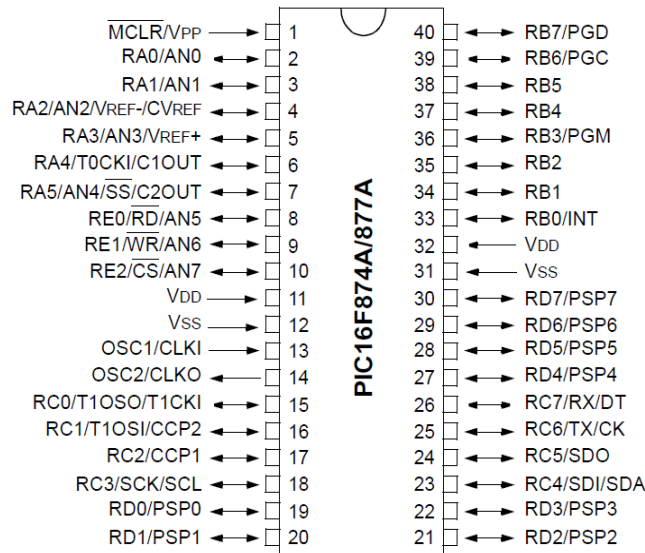

Fig 4: Pin diagram of PIC16f877A

**B. SRF02 SONAR SENSOR**

The SRF02 is a single transducer ultrasonic rangefinder in a small footprint PCB. It features both I2C and a Serial interfaces. The serial interface is a standard TTL level UART format at 9600 baud, 1 start, 2 stop and no parity bits, and may be connected directly to the serial ports on any microcontroller. Up to 16 SRF02's may be connected together on a single bus, either I2C or Serial. New commands in the SRF02 include the ability to send an ultrasonic burst on its own without a reception cycle, and the ability to perform a reception cycle without the preceding burst. This has been as requested feature on our sonar's and the SRF02 is the first to see its implementation. Because the SRF02 uses a single transducer for both transmission and reception, the minimum range is higher than our other dual transducer rangefinders. The minimum measurement range is around 15cm (6 inches). Like all our rangefinders, the SRF02 can measure in uS, cm or inches. There are two operating modes for the SRF02. I2C mode and Serial Mode. This is set with the Mode pin, connected to 0v Ground for Serial Mode and left unconnected (or tied to +5v Vcc) for I2C Mode.

Sonar, like radar, uses the principle of echo location. For echo location, a short pulse is sent in a specific direction (XMIT). When the pulse hits an object, which does not absorb the pulse, it bounces back, after which the echo can be picked up by a detector circuit.

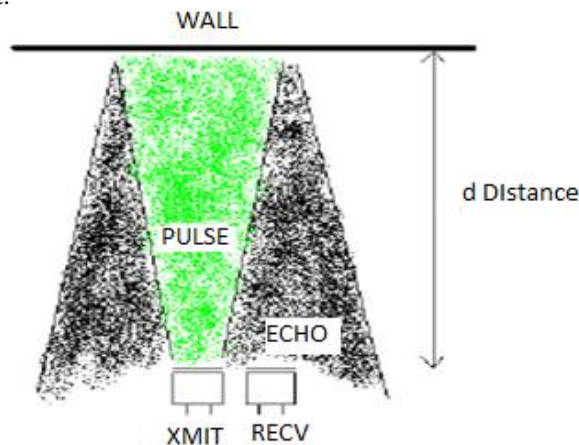

Fig 5: Working of Ultrasonic Sensor



## International Journal of Innovative Research in Science, Engineering and Technology

(An ISO 3297: 2007 Certified Organization)

Vol. 3, Issue 2, February 2014

By measuring the time between sending the pulse and detecting the echo, the distance to the object can be determined. I.e. sound travels at a speed of 343 meters per second through air at room temperature. By multiplying the time between pulse and echo (in seconds) with 343, you will get twice the distance to the object in meters (since the sound traveled the distance twice to get to the object and bounce back):

$$2d = V_{\text{sound}} \times (T_{\text{pulse}} - T_{\text{echo}})$$

V sound = speed of sound-travel (343meters/second)

T pulse = time in seconds of pulse transmission

T echo = time in seconds of echo detection

d = distance to object onto which pulse bounces back

### C. APR9600: Single-Chip Voice Recording & Playback Device 60-Second Duration

The APR9600 device offers true single-chip voice recording, non-volatile storage and playback capability for 40 to 60 seconds. The device supports both random and sequential access of multiple messages. Sample rates are user-selectable, allowing designers to customize their design for unique quality and storage time needs. Integrated output amplifier, microphone amplifier, and AGC circuits greatly simplify system design. The device is ideal for use in portable voice recorders, toys, and many other consumer and industrial applications. APLUS integrated achieves these high levels of storage capability by using its proprietary analog/multilevel storage technology implemented in an advanced Flash non-volatile memory process, where each memory cell can store 256 voltage levels. This technology enables the APR9600 device to reproduce voice signals in their natural form. It eliminates the need for encoding and compression, which often introduce distortion. The APR9600 block diagram is included in order to give understanding of the APR9600 internal architecture. At the left hand side of the diagram are the analog inputs. A differential microphone amplifier, including integrated AGC, is included on-chip for applications requiring its use. The amplified microphone signal is fed into the device by connecting the Ana Out pin to the Ana In pin through an external DC blocking capacitor. Recording can be fed directly into the Ana In pin through a DC blocking capacitor, however, the connection between Ana In and Ana Out is still required for playback. The next block encountered by the input signal is the internal anti-aliasing filter. The filter automatically adjusts its response according to the sampling frequency selected so Shannon's Sampling Theorem is satisfied. After anti-aliasing filtering is accomplished the signal is ready to be clocked into the memory array.

This storage is accomplished through a combination of the Sample and Hold circuit and the Analog Write/Read circuit. These circuits are clocked by either the Internal Oscillator or an external clock source. When playback is desired the previously stored recording is retrieved from memory, low pass filtered, and amplified as shown on the right hand side of the diagram. The signal can be heard by connecting a speaker to the SP+ and SP- pins. Chip-wide management is accomplished through the device control block shown in the upper right hand corner. Message management is controlled through the message control block represented in the lower center of the block diagram. More detail on actual device application can be found in the Sample Applications section. More detail on sampling control can be found in the Sample Rate and Voice Quality section. More detail on message management and device control can be found in the Message Management section.

### D. GPS-Global Positioning System

Earth has 24 GPS satellites, atleast 4 are always visible .GPS receiver calculates location using Triangulation method. 66 Channel GPS receiver interfaced via NMEA Protocol .The smart antenna can track upto 66 satellites at a time.Fast time to first fix, Superior sensitivity, and Low power.Less than 10m Accuracy. 57600bps UART interface.Up to 10Hz update rate. Built-in micro battery to preserve system data for rapid satellite acquisition.LED indicator for fix or no fix.



Fig 6: GPS Component

# International Journal of Innovative Research in Science, Engineering and Technology

(An ISO 3297: 2007 Certified Organization)

Vol. 3, Issue 2, February 2014

## E. Radio-frequency Identification System

Radio-frequency identification (RFID) is the use of radio-frequency electromagnetic fields through wireless to transfer data from the tag of an object for system identification and tracking. The tag contains electronic stored information that can be identified from some meters away. The tag is usually embedded in the object and does not need to be in the sight line of the person to be read. The Radio-frequency identification is more used in the canes for the blind people as it is unaffected by poor lighting conditions or any other constraints that impede the performance of other systems [10]. The use of the RFID system became widespread as it offers its users a wide range of products depending on whether it includes a battery or not, which will give the canes' users more flexibility in choosing the cane that best meets their needs [11].

## F. GSM-Global System for Mobile communication

The SIM900D is a complete Quad-band GSM/GPRS solution in a SMT module which can be embedded in the customer applications.

Featuring an industry-standard interface, the SIM900D delivers GSM/GPRS 850/900/1800/1900MHz performance for voice, SMS, Data, and Fax in a small form factor and with low power consumption. With a tiny configuration of 33mm x 33mm x 3 mm, SIM900D can fit almost all the space requirements in your M2M application, especially for slim and compact demand of design. SIM900D is designed with a very powerful single-chip processor integrating AMR926EJ-S core. Quad – band GSM/GPRS module with a size of 33mmx33mmx3mm.SMT type suit for customer application. An embedded Powerful TCP/IP protocol stack. Based upon mature and field-proven platform, backed up by our support service, from definition to design and production.

## VI. CONCLUSION

An attempt has been made to make a compact and portable device which is exclusively designed for visually impaired people. It will allow the visually impaired person to travel through an unfamiliar environment with ease. It can be said that the project provides Silicon Eye for visually impaired people.

## REFERENCES

- [1] Harshad Girish Lele, Viten Vilas Lonkar, Varun Vasant Marathe, Mrunmayi Mohan Modak. "electronic path guidance for visually impaired people." The International Journal Of Engineering And Science (IJES), 09-14, 2013.
- [2] Alshbatat, Abdel Ilah Nour. "Automated Mobility and Orientation System for Blind or Partially." INTERNATIONAL JOURNAL ON SMART SENSING AND INTELLIGENT SYSTEMS, 568-582, 2013.
- [3] Mahdi Safaa A., Muhsin Asaad H. and Al-Mosawi Ali I. "Using Ultrasonic Sensor for Blind and Deaf persons Combines Voice." International Science Congress Association, 50-52, 2012.
- [4] Lamya El alamy, Sara Lhaddad, Soukaina Maalal, Yasmine Taybi, Yassine Salih-Alj. "Bus Identification System for Visually Impaired Person." International Conference on Next Generation Mobile Applications, Services and Technologies, pp.13-17, 2012.
- [5] M. Nassih, I. Cherradi, Y. Maghous, B. Ouriaghli and Y. Salih-Alj. "Obstacles Recognition System for the Blind People Using RFID." Sixth International Conference on Next Generation Mobile Applications, Services and Technologies, pp. 60-63, 2012.
- [6] S. Sai Santhosh, T. Sasiprabha, R. Jeberson,. "BLI – NAV Embedded Navigation System for Blind People." IEEE, 277-282, 2010:.
- [7] A. R. García, R. Fonseca. A. Durán. "Electronic long cane for locomotion improving on visual impaired people." IEEE, pp.58-61, 2011.
- [8] Mohd Helmy Abd Wahab, Amirul A. Talib, Herdawatie A. Kadir, Ayob Johari, A.Noraziah, Roslina M. Sidek, Ariffin A. "Smart Cane: Assistive Cane for Visually-impaired People." IJCSI International Journal of Computer Science Issues, pp. 21-27,july 2011.
- [9] Batu Ferringhi, Penang "ROVI: A Robot for Visually Impaired for Collision- Free Navigation" Proceedings of the International Conference on Man-Machine Systems (ICoMMS) 11 – 13, , MALAYSIA , October 2009
- [10] "Electronic Interfaces Aiding the Visually Impaired in Environmental Access, Mobility and Navigation" 978-1-4244-7562-9/107©2010 IEEE.POLAND, pp. 13-15, 2010
- [11] K. Steed-Terry, "Integrating GIS and the Global Positioning System," 2nd ed. ESRI inc. pp.1–12, 2001.
- [12] A. Hub and B. Schmitz, "Addition of RFID-Based Initialization and Object Recognition to the Navigation System TANIA," Visualization and Interactive Systems Group, Stuttgart, 2009.