

An Inversion-Based Approach to Fault Detection and Isolation in Switching Electrical Networks

Aneel Tanwani, *Student Member, IEEE*, Alejandro D. Domínguez-García, *Member, IEEE*, and Daniel Liberzon, *Senior Member, IEEE*

Abstract—This paper proposes a framework for fault detection and isolation (FDI) in electrical energy systems based on techniques developed in the context of invertibility of switched systems. In the absence of faults—the nominal mode of operation—the system behavior is described by one set of linear differential equations or more in the case of systems with natural switching behavior, e.g., power electronics systems. Faults are categorized as *hard* and *soft*. A hard fault causes abrupt changes in the system structure, which results in an uncontrolled transition from the nominal mode of operation to a faulty mode governed by a different set of differential equations. A soft fault causes a continuous change over time of certain system structure parameters, which results in unknown additive disturbances to the set(s) of differential equations governing the system dynamics. In this setup, the dynamic behavior of an electrical energy system (with possible natural switching) can be described by a switched state-space model where each mode is driven by possibly known and unknown inputs. The problem of detection and isolation of hard faults is equivalent to uniquely recovering the switching signal associated with uncontrolled transitions caused by hard faults. The problem of detection and isolation of soft faults is equivalent to recovering the unknown additive disturbance caused by the fault. Uniquely recovering both switching signal and unknown inputs is the concern of the (left) invertibility problem in switched systems, and we are able to adopt theoretical results on that problem, developed earlier, to the present FDI setting. The application of the proposed framework to fault detection and isolation in switching electrical networks is illustrated with several examples.

Index Terms—Electrical energy systems, fault detection and isolation (FDI), invertibility, switched linear systems, switch-singular pairs.

I. INTRODUCTION

FAULT-TOLERANCE (self-healing) may be defined as the ability of a system to adapt and compensate in a planned, systematic way to random component faults and keep delivering completely or partially the functionality for which it was designed [1]. Two main elements should be engineered into an

electrical energy system to ensure fault-tolerance: 1) component redundancy and 2) fault detection and isolation mechanisms. Choosing the appropriate level of redundancy impacts other metrics, e.g., cost and weight. In this regard, the problem of optimal redundancy allocation has been addressed before [2]. The task of fault detection and isolation (FDI) is indispensable to ensure that component redundancy is managed appropriately. Failure to remove the faulty component from the system, even with sufficient redundant resources to tackle the fault, may entail further damage in other components and eventually bring the system down. A fault detection and isolation (FDI) system executes two actions: 1) detection makes a binary decision whether or not a fault has occurred and 2) isolation determines the fault location, i.e., which component is faulty.

The literature in FDI is extensive [3]–[6], and the methods used for the implementation of FDI can be broadly classified into three different categories:

- 1) *model-based*: uses control-theoretic methods to design residual generators that can point to specific faults;
- 2) *artificial intelligence*: uses neural networks and fuzzy logic to develop expert systems that once trained can point to specific faults;
- 3) *empirical and signal processing*: use spectral analysis to identify specific signatures of a certain fault.

The following are a few references of each category application to FDI in electrical energy systems. The work in [7]–[11] is model-based, artificial intelligence methods are used in [12]–[15], and empirical and signal processing methods in [16] and [17].

The focus of this work is on model-based FDI methods, the foundations of which are built on control-theoretic concepts. Model-based methods include observer-based and parameter estimation approaches [18]. As the proposed work is closer to observer-based FDI, fundamental ideas behind this approach to FDI will be reviewed. Observer-based FDI was first introduced by Beard in [19] and further developed by Jones in [20]. The idea is based on using a Luenberger observer (see, e.g., [21]). In a non-switched linear system, it can be used to estimate the system states, given some output measurements and the inputs to the system. In the absence of faults, the state estimates obtained from the observer converge to the actual state values asymptotically. If a fault occurs, the state predicted with the Luenberger observer no longer converges to the true state of the system. By appropriately choosing the observer gain, the estimation error in the presence of a certain fault has certain geometrical characteristics that make the fault identifiable. The Beard-Jones approach is only applicable to deterministic linear

Manuscript received January 14, 2010; revised June 24, 2010; accepted July 28, 2010. Manuscript received in final form August 09, 2010. Date of publication October 07, 2010; date of current version August 17, 2011. Recommended by Associate Editor N. H. El-Farra. The work of A. Tanwani and D. Liberzon was supported by NSF under Grant ECCS-0821153. The work of A. D. Domínguez-García was supported by NSF under Grant ECCS-0954420.

The authors are with the Department of Electrical and Computer Engineering, University of Illinois at Urbana-Champaign, Urbana-Champaign, IL 61801 USA (e-mail: tanwani2@illinois.edu; aledan@illinois.edu; liberzon@illinois.edu).

Color versions of one or more of the figures in this paper are available online at <http://ieeexplore.ieee.org>.

Digital Object Identifier 10.1109/TCST.2010.2067214

time-invariant systems (LTI). The idea of using observers for FDI was extended to stochastic systems, where a Kalman filter approach was used to formulate the FDI problem [22]. This overcame the limitations of the Beard-Jones approach. There has been some work on FDI for nonlinear systems (see, e.g., [23]), where linearization around the system operating point, together with FDI techniques for linear systems, is used. The limitations of this approach are obvious. The Beard-Jones approach cannot handle systems with inherent switching behavior, e.g., power electronics systems. The goal of this research is to overcome these limitations by developing methods that apply to both non-switched and switched linear systems. To address this problem, the application of recent results in invertibility of switched systems will be investigated [24], [25].

In our framework, the system behavior in the absence of faults is described by a set of linear dynamical equations. Faults are categorized as hard, the occurrence of which causes an abrupt change in the system structure, and soft, which result in continuous variation of certain parameters of the system structure. When a hard fault occurs, the system trajectories follow a different set of linear dynamical equations and it is assumed that the dynamics of the system in the presence of such faults are known. If there is a finite number of hard faults under consideration, then we have a finite number of dynamical subsystems describing each possible system operational mode, including the nominal modes and all possible faulty modes. The occurrence of a hard fault results in the transition from a non-faulty mode to a faulty mode. The occurrence of soft faults will result in additional unknown forces driving the system dynamics. In this regard, the system can be thought of as a switched system where the switching signal and inputs are possibly unknown. In this setup, detecting and isolating a hard fault is equivalent to uniquely recovering the switching signal associated with the transition caused by the fault. Detection and isolation of soft faults is equivalent to recovering the unknown inputs that arise from the fault occurrence. To achieve this, we will use the notion of invertibility for switched systems. The problem of (left) invertibility of switched systems, introduced in [24], concerns with the recovery of switching signal and input using the knowledge of the output and the initial state. The realization of FDI using invertibility can be summarized as follows. For hard faults, detection is equivalent to determining that the non-faulty mode can no longer produce the observed outputs, and isolation is equivalent to uniquely recovering the switching signal by identifying which faulty mode can produce the observed output. For soft faults, detection is equivalent to detecting the presence of an input disturbance, isolation is equivalent to uniquely identifying the parameter change that cause this input disturbance to appear.

In the framework of non-switched systems, the problem of FDI using classical invertibility techniques has been studied before in [26]. In this work, the authors consider faults as additive unknown inputs to the system, and recover them as outputs of another dynamic system—the inverse system. Since the initial values of the state variables are not assumed to be known, the authors require the inverse system to be minimum phase which is possible for non-switched systems. Also, minimal realization is considered to save excessive computational effort. In this paper, we also model soft faults as additive unknown inputs to

the system. As the systems under consideration are switched systems, classical inversion techniques can no longer be used for detection of such faults and hence we use newly developed tools of invertibility for switched systems [24]. Also, we assume the initial conditions to be known and hence do not require stability of the inverse system. Furthermore, we do not consider using a minimal realization of the inverse system because the state variables of these minimal realizations for different modes might not coincide and therefore mode detection would not be possible.

The structure of this paper is as follows. In Section II, the system dynamical model, the notations and the formulae that lead to the construction of an inverse switched system are presented. In Section III, the notions introduced in Section II are used to construct the proposed FDI framework. Section IV presents several case-studies that illustrate the ideas presented in Section III, followed by some simulation results in Section V. Concluding remarks are presented in Section VI.

II. PRELIMINARIES: INVERSION OF DYNAMICAL SYSTEMS

In the context of this work, it is assumed that, without loss of generality, the dynamic behavior of switching electrical systems can be described by a switched state-space model¹ of the form

$$\Gamma : \begin{cases} \dot{x} = A_\sigma x + B_\sigma u + E_\sigma v \\ y = C_\sigma x \end{cases} \quad (1)$$

where $x \in \mathbb{R}^n$, $u(t) \in \mathbb{R}^m$, $v(t) \in \mathbb{R}^r$, $y(t) \in \mathbb{R}^l$, the function $\sigma : [0, \infty) \rightarrow \mathcal{P}$, called the switching signal,² indicates the active subsystem at every time, \mathcal{P} is called the “index set,” and A_p, B_p, C_p, E_p with $p \in \mathcal{P}$ define the subsystems in (1). The input u is assumed to be unknown, whereas the input v is assumed to be known.

For a fixed $p \in \mathcal{P}$ and known v , denote by $\Gamma_{p,x_0}(u)$ the trajectory of the corresponding subsystem with the initial state x_0 and the input u , and the corresponding output by $\Gamma_{p,x_0}^O(u)$. Since switching signals are right-continuous, the outputs are also right-continuous and whenever we take derivative of the output, we assume it is the right derivative.

A. Invertibility of Non-Switched Linear Systems

Consider affine linear systems of the form

$$\dot{x} = Ax + Bu + Ev \quad (2a)$$

$$y = Cx \quad (2b)$$

where u is assumed to be unknown and v is assumed to be known.

The invertibility problem for linear systems concerns with finding conditions for a LTI system so that for a given initial state x_0 and known input v , the input-output map $H_{x_0,v} : \mathcal{U} \rightarrow \mathcal{Y}$ is injective (left invertibility) or surjective (right invertibility), where \mathcal{U} is the space of input functions u and \mathcal{Y} is the corresponding output function space. The main computational tool for studying the problem in an algebraic

¹For a detailed discussion on the conditions for existence of solutions of switched systems the reader is referred to [27].

²A switching signal, as defined in [27], is a piecewise constant and everywhere right-continuous function that has a finite number of discontinuities τ_i , which we call *switching times*, on every bounded time interval and thus $\sigma(t) = p \in \mathcal{P}, \forall t \in [\tau_i, \tau_{i+1})$.

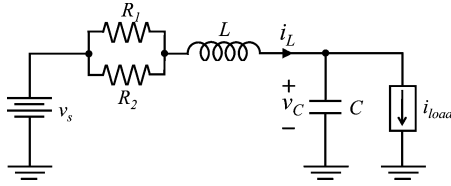

Fig. 1. RLC circuit.

setting is the *structure algorithm*, introduced in [28] and [29]. In the original formulation of this algorithm, it was assumed that all inputs were unknown. In this section, we tailor this formulation to the system (2), where some inputs are known, which is a more appropriate formulation for the FDI framework to be discussed in Section III. Before proceeding with the formal formulation of the structure algorithm, we introduce an example that will help illustrating the main ideas behind it.

1) *Example 1*: Consider the circuit of Fig. 1, where it is assumed that the input voltage v_s is known, the load current i_{load} is unknown, and both the states i_L and v_C are measurable. By using the notation of (2), $x = [i_L \ v_C]^T$, $u = i_{load}$, $v = v_s$, $y = [y_1 \ y_2]^T = [i_L \ v_C]^T$, and

$$A = \begin{bmatrix} -\frac{R_1 R_2}{(R_1 + R_2)L} & -\frac{1}{L} \\ \frac{1}{C} & 0 \end{bmatrix}, \quad B = \begin{bmatrix} 0 \\ -\frac{1}{C} \end{bmatrix} \\ E = \begin{bmatrix} \frac{1}{L} \\ 0 \end{bmatrix}, \quad C = \begin{bmatrix} 1 & 0 \\ 0 & 1 \end{bmatrix}. \quad (3)$$

The main idea behind the structure algorithm is that by differentiating the output, it is possible under certain conditions to invert the system, i.e., find a one-to-one mapping between the output (and its derivatives) and the unknown input. In this example, it is straightforward to find such a mapping by differentiating the second output: $\dot{y}_2 = [1/C \ 0]x - (1/C)i_{load}$, from where it follows that the unknown input i_{load} can be uniquely recovered from the output and its derivatives: $i_{load} = i_L - C\dot{y}_2$. Another important observation for solving the problem of inversion in switched affine linear systems, and later formalized in the form of the so-called *range theorem* [29], can be made regarding the outputs that can be generated by the system from all possible initial conditions. To explore the idea behind the generation of such an output set, consider the state-space description of a system without inputs which is not necessarily observable. For such a system, higher order derivatives of the output can be written as a linear combinations of its lower order derivatives. Similarly, for the system of Fig. 1, it is easy to verify that the outputs produced by this system satisfy the constraint: $\dot{y}_1 + (1/L)\dot{y}_2 + (R_1 R_2 / (R_1 + R_2))L\dot{y}_1 = (1/L)\dot{v}_s$. The construction is later formalized in this section. To determine how the outputs in this set are related to the state variables, consider the relation between outputs and states given by the observation equation $y = Cx$ and differentiate the first output: $\dot{y}_1 = [-(R_1 R_2 / (R_1 + R_2))L \ -1/L]x + (1/L)v_s$. It follows that the output and the state are related by the following functional relation:

$$\begin{bmatrix} 1 & 0 \\ 0 & 1 \\ \frac{d}{dt} & 0 \end{bmatrix} y = \begin{bmatrix} 1 & 0 \\ 0 & 1 \\ -\frac{R_1 R_2}{(R_1 + R_2)L} & -\frac{1}{L} \end{bmatrix} x + \begin{bmatrix} 0 \\ 0 \\ \frac{1}{L} \end{bmatrix} v_s. \quad (4)$$

Such relations are useful in mode identification of switched systems especially when the subsystems have same output sets. \triangleleft

2) *Structure Algorithm*: We now proceed to formalize the ideas introduced in Example 1. Consider the linear system (2). Differentiate y to get $\dot{y} = C\dot{x} = CAx + CBu + CEv$; let $q_1 = \text{rank}(CB)$, then there exists a nonsingular $l \times l$ matrix S_1 such that $D_1 := S_1 CB = \begin{bmatrix} \bar{D}_1 \\ 0 \end{bmatrix}$, where \bar{D}_1 has q_1 rows and rank q_1 . Let $y_1 = S_1 \dot{y}$; $C_1 := S_1 CA$, and $E_1 := S_1 CE$. Thus, we have $y_1 = C_1 x + D_1 u + E_1 v_1$, where $v_1 = v$. Suppose that at step k , we have $y_k = C_k x + D_k u + E_k v_k$, where D_k has the form $\begin{bmatrix} \bar{D}_k \\ 0 \end{bmatrix}$; \bar{D}_k has q_k rows and is full rank. Let the partition of C_k, E_k be $\begin{bmatrix} \bar{C}_k \\ \check{C}_k \end{bmatrix}, \begin{bmatrix} \bar{E}_k \\ \check{E}_k \end{bmatrix}$, respectively, where \bar{C}_k, \bar{E}_k are the first q_k rows; y_k is partitioned as $\begin{bmatrix} \bar{y}_k \\ \check{y}_k \end{bmatrix}$, where \bar{y}_k has the first q_k elements; and v_k has the form $[v', \dot{v}', \dots, v^{(k-1)}]'$. If $q_k < l$, let M_k be the differential operator

$$M_k := \left[\begin{array}{c|c} I_{q_k} & 0 \\ \hline 0 & I_{l-q_k}(d/dt) \end{array} \right].$$

Then

$$M_k y_k = \begin{bmatrix} \bar{C}_k \\ \check{C}_k \end{bmatrix} x + \begin{bmatrix} \bar{D}_k \\ \check{C}_k \end{bmatrix} u + \begin{bmatrix} \bar{E}_k & 0_{q_k \times r} \\ \check{C}_k E & \check{E}_k \end{bmatrix} v_{k+1}$$

where

$$v_{k+1} := [v', \dot{v}', \dots, v^{(k)}]'$$

Let

$$q_{k+1} = \text{rank} \begin{bmatrix} \bar{D}_k \\ \check{C}_k B \end{bmatrix}$$

then there exists a nonsingular $l \times l$ matrix S_{k+1} such that

$$D_{k+1} := S_{k+1} \begin{bmatrix} \bar{D}_k \\ \check{C}_k B \end{bmatrix} = \begin{bmatrix} \bar{D}_{k+1} \\ 0 \end{bmatrix}$$

where D_{k+1} has q_{k+1} rows and rank q_{k+1} . Let $y_{k+1} := S_{k+1} M_k y_k$

$$C_{k+1} := S_{k+1} \begin{bmatrix} \bar{C}_k \\ \check{C}_k A \end{bmatrix} \\ E_{k+1} := S_{k+1} \begin{bmatrix} \bar{E}_k & 0_{q_k \times r} \\ \check{C}_k E & \check{E}_k \end{bmatrix}.$$

Then $y_{k+1} = C_{k+1}x + D_{k+1}u + E_{k+1}v_{k+1}$ and we can repeat the procedure. Let $N_k := \prod_{i=0}^k S_{k-i} M_{k-i-1}$, $k = 1, 2, \dots, (M-1 := I; S_0 := I)$, $\bar{N}_k := [I_{q_k} \ 0_{q_k \times (l-q_k)}] N_k$, and $\check{N}_k := [0_{(l-q_k) \times q_k} \ I_{l-q_k}] N_k$. Then $y_k = N_k y$, $\bar{y}_k = \bar{N}_k y$, and $\check{y}_k = \check{N}_k y$. Using these notations, $y = y_0 = \check{y}_0 = \check{C}_0 x = Cx$, $E_0 = 0$, and $D_0 = 0$. Notice that since D_k has l rows and m columns, $q_k \leq \min\{l, m\}$ for all k and since $q_{k+1} \geq q_k$, using the Cayley-Hamilton theorem, it was shown in [29] that there exists a smallest integer $\alpha \leq n$ such that $q_k = q_\alpha, \forall k \geq \alpha$. If $q_\alpha = m$, the system is left-invertible and the inverse is

$$\Gamma^{-1} : \begin{cases} \bar{y}_\alpha = \bar{N}_\alpha y \\ \dot{z} = (A - B\bar{D}_\alpha^{-1}\bar{C}_\alpha)z - B\bar{D}_\alpha^{-1}\bar{E}_\alpha v_\alpha + Ev + B\bar{D}_\alpha^{-1}\check{y}_\alpha \\ u = -\bar{D}_\alpha^{-1}\check{C}_\alpha z - \bar{D}_\alpha^{-1}\check{E}_\alpha v_\alpha + \bar{D}_\alpha^{-1}\check{y}_\alpha \end{cases} \quad (5)$$

with the initial state $z(0) = x_0$.

3) *The Range Theorem*: From the structure algorithm, it can be seen that $\tilde{N}_k y = \tilde{y}_k = \tilde{C}_k x + \tilde{E}_k v_k$, for each k and hence

$$\tilde{Y}_k = L_k x + J_{k-1} v_{k-1} \quad (6)$$

where

$$\tilde{Y}_k = \begin{bmatrix} \tilde{y}_0 \\ \vdots \\ \tilde{y}_{k-1} \end{bmatrix} = \begin{bmatrix} \tilde{N}_0 \\ \vdots \\ \tilde{N}_{k-1} \end{bmatrix} y$$

$$L_k = \begin{bmatrix} \tilde{C}_0 \\ \vdots \\ \tilde{C}_{k-1} \end{bmatrix}, \quad J_k = \begin{bmatrix} \tilde{E}_1 & 0_{(l-q_0) \times (k-1)r} \\ \vdots & \vdots \\ \tilde{E}_k & 0_{(l-q_k) \times 0} \end{bmatrix}.$$

Using the Cayley-Hamilton theorem, Silverman and Payne have shown in [29] that there exists a smallest number β , $\alpha \leq \beta \leq n$, such that $\text{rank}(L_k) = \text{rank}(L_\beta)$, $\forall k \geq \beta$. There also exists a number δ , $\beta \leq \delta \leq n$ such that $\tilde{C}_\delta = \sum_{i=0}^{\delta-1} P_i \left(\prod_{j=i+1}^{\delta} \tilde{R}_j \right) \tilde{C}_i$ for some matrices \tilde{R}_j from the structure algorithm and some constant matrices P_i (see [29, p. 205] for details). The number δ is not easily determined as α and β . The significance of α , β , and δ is that they can be used to characterize the set of all outputs of a linear system as in the range theorem [29, Th. 4.3]. We include the range theorem from [29] below in a modified form because of the presence of known input v . The proof however follows the same argument and is not repeated here. Define the differential operators $\mathbf{M}_1 := \left(d^\delta / dt^\delta - \sum_{i=0}^{\delta-1} P_i d^i / dt^i \right) \prod_{j=0}^{\alpha} \tilde{R}_j$ and $\mathbf{M}_2 := \sum_{j=0}^{\delta} \left(\prod_{l=j+1}^{\alpha} \tilde{R}_l \right) K_j d^{\delta-j} / dt^{\delta-j} - \sum_{j=0}^{\delta-1} \sum_{k=0}^j \left(\prod_{l=k+1}^{\alpha} \tilde{R}_l \right) K_j d^{j-k} / dt^{j-k}$ for some matrices K_i from the structure algorithm. The notation $|_t$ means “evaluating at t .”

Theorem 1 [29]: A function $f : [t_0, T] \rightarrow \mathbb{R}^l$ is in the range of Γ_{x_0} if and only if

- (i) f is such that $N_\delta f$ is defined and continuous;
- (ii) $\tilde{N}_k f|_{t_0} = \tilde{C}_k x_0 + \tilde{E}_k v_k|_{t_0}$, $k = 0, \dots, \delta - 1$;
- (iii) $(\mathbf{M}_1 - \mathbf{M}_2 \tilde{N}_\alpha) f(t) = \tilde{E}_\delta v_\delta(t) - \sum_{i=0}^{\delta-1} P_i \left(\prod_{j=0}^{\alpha} \tilde{R}_j \right) \tilde{E}_i v_i(t)$ for all $t \in [t_0, T]$. \triangleleft

Compared to [29, Th. 4.1], condition (ii) in Theorem 1 of this paper has additional $\delta - \beta$ equations due to the presence of inhomogeneity v which, unlike [29], make the additional $\delta - \beta$ constraints linearly independent of the first β equations. Condition (iii) also gets modified.

With the help of extra notations, the range theorem is paraphrased in the following proposition for better understanding. Let $\mathbf{N} := [\tilde{N}'_0 \ \dots \ \tilde{N}'_{\delta-1}]'$, $L := L_\delta$, $J := J_{\delta-1}$, $\nu = v_{\delta-1}$, \mathcal{C}^0 be the class of continuous functions, and denote by $\hat{\mathcal{Y}}$ the set of functions $f : \mathcal{D} \rightarrow \mathbb{R}^l$ for all $\mathcal{D} \subseteq [0, \infty)$ which satisfy (i) and (iii) of Theorem 1.

Proposition 1: For a linear system Γ , using the structure algorithm on the system matrices, construct a set $\hat{\mathcal{Y}}$ of functions, a differential operator $\mathbf{N} : \hat{\mathcal{Y}} \rightarrow \mathcal{C}^0$, and the matrices L, J . There exists $u \in \mathcal{C}^0$ such that $y = \Gamma_{x_0, v}^O(u)$ if and only if $y \in \hat{\mathcal{Y}}$ and $\mathbf{N}y|_{t_0^+} = Lx_0 + J\nu|_{t_0^+}$. \triangleleft

For square invertible systems with $q_\alpha = l = m$, condition (iii) in Theorem 1 always holds and the set $\hat{\mathcal{Y}}$ is simplified to the set of functions f for which $N_\delta f$ is defined and continuous. In particular, any \mathcal{C}^n function will be in $\hat{\mathcal{Y}}$. Also, note from the structure algorithm that regardless of what the unknown input is, the output, the state, and the known input are related by the equation $\mathbf{N}y|_t = Lx(t) + J\nu(t)$, for all $t \geq t_0$, not just at the initial time t_0 . It is important to note that Proposition 1 provides the necessary and sufficient condition in terms of a differential operator \mathbf{N} , some matrices L, J and some set of functions $\hat{\mathcal{Y}}$. Roughly speaking, the set $\hat{\mathcal{Y}}$ characterizes continuous functions that can be generated by the system from all initial positions (the components of the output must be related to the system matrices A, B, C in some sense). This relation will be used later to identify the mode of operation in a switched system as the condition $\mathbf{N}y|_{t_0^+} = Lx_0 + J\nu|_{t_0^+}$ guarantees that the particular y can be generated starting from the particular initial state x_0 and v at time t_0 . We evaluate $\mathbf{N}y$ and ν at t_0^+ , to reflect that y, ν do not need to be defined for $t < t_0$. This is especially useful later when we consider switched systems where inputs and outputs can be piecewise right-continuous.

B. Switched Linear Systems

For switched linear systems (1), the map under consideration is a (switching signal \times input)-output map $\mathbb{H}_{x_0, v} : \mathcal{S} \times \mathcal{U} \rightarrow \mathcal{Y}$, where \mathcal{S} is the space of switching signals. The problem of invertibility is to find a characterization of the output space \mathcal{Y} and a condition on the subsystems, independent of x_0 , such that the map $\mathbb{H}_{x_0, v}$ is injective. In other words, we are interested in knowing whether the preimage $(\sigma, u) = \mathbb{H}_{x_0, v}^{-1}(y)$ is unique. The issue of left-invertibility is of central importance in detection and isolation of hard faults because occurrence of a hard fault is the same as the transition of system from nominal mode to a faulty mode. Thus, recovering the unknown switching signal is equivalent to identifying the hard fault in the system.

The reason we have a different notion of invertibility is because in switched systems, if a subsystem is invertible at x_0 for a given output y , then it is possible that another subsystem might produce the same output starting from the same initial condition. This means that the pre-image of $\mathbb{H}_{x_0, v}$ at such (x_0, y) is not unique and hence the switched system is not invertible at x_0 if such pairs (x_0, y) exist. We call all such pairs *switch-singular pairs*.³ The concept of switch-singular pairs for switched systems basically refers to the ability of more than one subsystem to produce a segment of the desired output starting from the same initial condition. The formal definition of switch-singular pairs is given in the following.

Definition 1: Let $x_0 \in \mathbb{R}^n$ and $y \in \mathcal{C}^0$ on some time interval. The pair (x_0, y) is a *switch-singular pair* of the two subsystems Γ_p, Γ_q if there exist u_1, u_2 such that $\Gamma_{p, x_0}^O(u_1) = \Gamma_{q, x_0}^O(u_2) = y$. \triangleleft

We proceed to develop a formula for checking if (x_0, y) is a switch-singular pair of Γ_p, Γ_q , utilizing the range theorem by Silverman and Payne (Theorem 1 in this paper). We will use our notations in Proposition 1. For the subsystem indexed by

³This is similar to the concept of singular pairs conceived in [24]. We use the term “switch-singular pair” to emphasize that these singularities are induced by switching.

p , denote by \mathbf{N}_p , L_p , J_p , ν_p , and $\hat{\mathcal{Y}}_p$ the corresponding objects of interest as in Proposition 1. It follows from Definition 1 and Proposition 1 that (x_0, y) is a switch-singular pair if and only if $y \in \hat{\mathcal{Y}}_p \cap \hat{\mathcal{Y}}_q$ and

$$\begin{bmatrix} \mathbf{N}_p \\ \mathbf{N}_q \end{bmatrix} y|_{t_0^+} = \begin{bmatrix} L_p \\ L_q \end{bmatrix} x_0 + \begin{bmatrix} J_p \nu_p|_{t_0^+} \\ J_q \nu_q|_{t_0^+} \end{bmatrix} \quad (7)$$

where t_0 is the initial time of y . For a given (x_0, y) , the condition (7) can be directly verified as all entities are known. One special case is $x_0 = 0, v \equiv 0, y \equiv 0$. It is obvious that with $u = 0$ and any switching signal, we always have $y \equiv 0$, i.e., $H_{0,0}(\sigma, u) = 0 \forall \sigma$ regardless of the subsystem dynamics and therefore, the map $H_{x_0, v}$ is not one-to-one if the function $0 \in \mathcal{Y}$. So, whenever $\begin{bmatrix} \mathbf{N}_p \\ \mathbf{N}_q \end{bmatrix} y|_{t_0^+} = 0$, there exists an x_0 that forms switch-singular pair with such outputs.

Essentially, if a state and an output function (the time domain can be arbitrary) form a switch-singular pair, then there exist inputs for the two systems to produce that same output starting from that same initial state. Stated otherwise, if there are no switch-singular pairs between any of the subsystems then the active subsystem is determined uniquely. From fault detection viewpoint, the absence of switch-singular pairs guarantees the detection and isolation of faults as demonstrated in Example 3 of Section III.

Based on the concept of switch-singular pairs, it has been shown in [24] that a switched system is invertible if and only if all subsystems are invertible and subsystem dynamics are such that there exist no switch-singular pairs among them. If these conditions are satisfied and the switched system is invertible, a switched inverse system can be constructed to recover the input u and switching signal σ from the knowledge of given x_0, y , and v . For the switched inverse system, let $\tilde{\mathcal{Y}}$ be the set of piecewise smooth functions such that if $y \in \tilde{\mathcal{Y}}$ and $y|_{[t_0, t_0+\varepsilon)} \in \hat{\mathcal{Y}}_p \cap \hat{\mathcal{Y}}_q$ for some $p \neq q, p, q \in \mathcal{P}, \varepsilon > 0$ then (7) does not hold. Define the *index inversion function* $\tilde{\Sigma}^{-1} : \mathbb{R}^n \times \tilde{\mathcal{Y}} \rightarrow \mathcal{P}$ as

$$\begin{aligned} \tilde{\Sigma}^{-1}(x_0, y) &= p : y|_{[t_0, t_0+\varepsilon)} \in \hat{\mathcal{Y}}_p \text{ and} \\ \mathbf{N}_p y|_{t_0^+} &= L_p x_0 + J_p \nu_p|_{t_0^+} \end{aligned} \quad (8)$$

where t_0 is the initial time of y , and $x_0 = x(t_0)$. The function $\tilde{\Sigma}^{-1}$ is well-defined since p is unique by the fact that there are no switch-singular pairs. The existence of p is guaranteed if it is assumed that $y \in \tilde{\mathcal{Y}}$ is an output from the modeled switched system.

III. INVERSION-BASED FDI

We categorize faults in electrical energy systems as *hard faults* and *soft faults*. Hard faults often result in an abrupt change of the system structure; examples include component open- and short-circuits or certain switching elements getting stuck in an open or close position. We assume that the system configuration resulting from the hard faults can be modeled. Then in the context of the switched state-space description (1) discussed in the previous section, a hard fault can be thought of as an uncontrolled transition between two modes in \mathcal{P} . Soft faults, on the other hand, refer to a continuous variation—as opposed to an abrupt change—in certain parameters over the

period of time; they may occur due to graceful degradation of the capacitance or the equivalent series resistance (ESR) of a capacitor. In the context of the switched state-space description (1), a soft fault can be thought of as an unknown additive disturbance and therefore can be naturally included in the vector of unknown inputs u .

The problem of detection and isolation of hard faults is equivalent to uniquely recovering the switching signal associated with the uncontrolled transition caused by the fault. The problem of detection and isolation of soft faults is equivalent to recovering the unknown additive disturbance caused by the fault. The theoretical concepts discussed in Section II are the foundations to develop the framework introduced in this section for detection and isolation of hard and soft faults in systems with inherent switching.

A. Generalized System Model

The state-space description given in (1) can be tailored to describe the non-faulty behavior of an electrical energy system with inherent switching and the faulty features described above. In this regard, the index set \mathcal{P} of (1) is partitioned into two sets such that $\mathcal{P} = \mathcal{N} \cup \mathcal{F}$. The first set \mathcal{N} contains the non-faulty modes among which transitions occurs due to the possible inherent system switching, e.g., the different physical configurations of a buck or a boost converter dictated by the controlled position of the switches. The second set \mathcal{F} contains the faulty modes that result from hard faults. Since the transitions from a mode in \mathcal{N} to a mode in \mathcal{F} are caused by a fault, these transitions are uncontrolled and, in general, unknown. The unknown system input u of (1) is also partitioned into two vectors as $u = [\mu \ \phi]'$. The first vector μ contains unknown inputs, e.g., a load in a buck converter modeled as a randomly varying current source, the measures of which are not available. The second vector ϕ contains unknown disturbances that arise due to soft faults.

Thus, formalizing the above ideas, system dynamic behavior under both non-faulty and faulty conditions can be described by a generalized switched state-space model of the form

$$\Gamma : \begin{cases} \dot{x} = A_\sigma x + B_\sigma u + E_\sigma v \\ y = C_\sigma x \end{cases} \quad (9)$$

where $x \in \mathbb{R}^n$, $u(t) = [\mu(t) \ \phi(t)]' \in \mathbb{R}^m$, $v(t) \in \mathbb{R}^r$, $y(t) \in \mathbb{R}^l$, $\sigma : [0, \infty) \rightarrow \mathcal{N} \cup \mathcal{F}$, and A_p, B_p, C_p, E_p with $p \in \mathcal{N} \cup \mathcal{F}$ defining the subsystems in (9).

1) *Example 2:* Consider again the circuit of Fig. 1 and assume the resistors R_1 and R_2 are subject to faults that can abruptly cause an open circuit across their terminals. Γ_1 represents the nominal mode of operation without any faults; Γ_2 describes the dynamics of the system when R_2 fails open, and Γ_3 corresponds to the case where R_1 fails open. Additionally the capacitor is subject to graceful degradation, thus its capacitance is given by $C(t) = C + \lambda_C(t)$, where C is the nominal capacitance, and the unknown function $\lambda_C(t) \leq 0$ captures the decrease in capacitance over time. Now, it is assumed that both the input voltage v_s and the load current i_{load} are known and both states i_L and v_C are measurable. In this scenario, following the notation of (9), $x = [i_L \ v_C]'$, $u(t) = \phi(t) = -(1/(C + \lambda_C(t)))$

$((\lambda_C(t)/C)(i_L - i_{\text{load}}) + v_C d\lambda_C/dt)$, $v = [v_s \quad i_{\text{load}}]'$, and $\sigma : [0, \infty) \rightarrow \mathcal{P}$, where $\mathcal{P} = \{1, 2, 3\}$ and

$$\Gamma_1 : A_1 = \begin{bmatrix} -\frac{R_1 R_2}{(R_1 + R_2)L} & -\frac{1}{L} \\ \frac{1}{C} & 0 \end{bmatrix}, B_1 = \begin{bmatrix} 0 \\ 1 \end{bmatrix} \\ E_1 = \begin{bmatrix} \frac{1}{L} & 0 \\ 0 & -\frac{1}{C} \end{bmatrix}, C_1 = \begin{bmatrix} 1 & 0 \\ 0 & 1 \end{bmatrix} \quad (10)$$

$$\Gamma_2 : A_2 = \begin{bmatrix} -\frac{R_1}{L} & -\frac{1}{L} \\ \frac{1}{C} & 0 \end{bmatrix}, B_2 = \begin{bmatrix} 0 \\ 1 \end{bmatrix} \\ E_2 = \begin{bmatrix} \frac{1}{L} & 0 \\ 0 & -\frac{1}{C} \end{bmatrix}, C_2 = \begin{bmatrix} 1 & 0 \\ 0 & 1 \end{bmatrix} \quad (11)$$

$$\Gamma_3 : A_3 = \begin{bmatrix} -\frac{R_2}{L} & -\frac{1}{L} \\ \frac{1}{C} & 0 \end{bmatrix}, B_3 = \begin{bmatrix} 0 \\ 1 \end{bmatrix} \\ E_3 = \begin{bmatrix} \frac{1}{L} & 0 \\ 0 & -\frac{1}{C} \end{bmatrix}, C_3 = \begin{bmatrix} 1 & 0 \\ 0 & 1 \end{bmatrix} \quad (12)$$

where A_1, B_1 describe the non-faulty circuit dynamics; A_2, B_2 describe the circuit dynamics after an open circuit in R_2 ; and A_3, B_3 describe the circuit dynamics after an open circuit in R_1 . It is important to note that the disturbance $\phi(t)$ due to capacitor degradation in reality arises as a perturbation of the state-space representation matrices. However, as it was shown in [20], and without loss of generality, it is always possible to rewrite this perturbation as an unknown additive disturbance as shown here. \triangleleft

It should be noted that, in the above example, ϕ denotes the degradation in the value of capacitance which is varying with time and is unknown. The capacitance can also be regarded as one of the model parameters and in the case of Example 2, this parameter is time varying and the variation in this parameter is unknown. So, in general, uncertainties in model parameters may also be included as part of the unknown vector u in (9).

B. Fault Detection and Isolation

The first step in designing a fault detection and isolation system is to obtain the system generalized model (9), which includes non-faulty modes, faulty modes arising from hard faults and unknown disturbances caused by soft faults.

Once this generalized model (9) is obtained, the problem of fault detection and isolation is equivalent to finding (σ, u) such that $H_{x_0, v}(\sigma, u) = y$, where $H_{x_0, v}$ is the input-output operator for a given initial state x_0 and a known input v , and y is the observed output. For (1), denote by $H_{x_0, v}^{-1}(y)$ the preimage of a function y

$$H_{x_0, v}^{-1}(y) := \{(\sigma, u) : H_{x_0, v}(\sigma, u) = y\}. \quad (13)$$

If the set in (13) reduces to a singleton, then the switched system is left invertible,⁴ that is, there is a unique switching signal and input that generates the given output.

It is entirely possible that the preimage $H_{x_0, v}^{-1}(y)$ is not unique. It happens because: 1) there is a subsystem that can produce the same output with more than one input u or 2) there is more than one subsystem that can produce the measured output. In the first case, there exist infinitely many inputs that

can produce a given output on any compact interval with same initial and terminal state [24, Lemma 4] and therefore, *it is not possible to detect and isolate the occurrence of a particular soft fault*. In the second case, it is the existence of switch-singular pairs that prevents the mode identification. If such pairs exist among *the faulty modes*, then *the occurrences of hard faults can still be detected but such faults cannot be isolated*. In practice, in order to compute $H_{x_0, v}^{-1}(y)$, it is necessary to: 1) conduct mode identification and 2) recover the unknown input u .

1) *Mode Detection or Hard Fault Detection and Isolation*: The first step to obtain the inverse system is to conduct mode identification using the *index-inversion function* which is defined as follows:

$$\bar{\Sigma}^{-1}(x_0, y) = p : y|_{[t_0, t_0 + \varepsilon]} \in \hat{\mathcal{Y}}_p \text{ and} \\ \mathbf{N}_p y|_{t_0^+} = L_p x_0 + J_p v_p|_{t_0^+}, p \in \mathcal{N} \cup \mathcal{F}. \quad (14)$$

If the resulting mode p is unique and belongs to \mathcal{N} , then the occurrence of a hard fault is ruled out. However, if p belongs to \mathcal{F} , then a hard fault occurrence has been detected. If (14) results in more than one p that belongs to \mathcal{F} but does not belong to \mathcal{N} , then a fault has occurred and it can be detected; however it is not possible to isolate the fault as the faulty mode that is producing the observed output cannot be identified. In case (14) results in modes that belong to \mathcal{N} and \mathcal{F} , then there is a switch-singular pair between a faulty and non-faulty mode, so one cannot conclude whether or not a fault has occurred.

It is true that the detection of hard faults depends upon the modeling of faulty modes and there maybe cases where an unmodeled fault has occurred. In this case, the observed output of the system is not related to any of the modes and the index-inversion function in (14) is ill-defined as the system is operating with unknown dynamics. So, in case the active mode cannot be identified then the system has switched to a faulty mode that has not been modeled. Hence, the detection is still possible but one cannot identify where the fault has occurred.

2) *Input Recovery or Soft Fault Detection and Isolation*: Once the mode has been identified, and perhaps a hard fault has been detected and isolated, it is still necessary to check for the presence of soft faults, which can be accomplished by inverting the particular subsystem associated to the mode identified in (14), and then recovering u from the inverse of that particular subsystem. Practically, this can be achieved by running the following inverse switched system:

$$\Gamma_{\sigma}^{-1} : \begin{cases} \sigma(t) = \bar{\Sigma}^{-1}(z(t), y|_{[t, t + \varepsilon]}) \\ \dot{z} = (A - B\bar{D}_{\alpha}^{-1}\bar{C}_{\alpha})_{\sigma(t)} z - (B\bar{D}_{\alpha}^{-1}\bar{E}_{\alpha})_{\sigma(t)} v_{\alpha} \\ \quad + E v + (B\bar{D}_{\alpha}^{-1}\bar{N}_{\alpha})_{\sigma(t)} y \\ u = (-\bar{D}_{\alpha}^{-1}\bar{C}_{\alpha})_{\sigma(t)} z - (\bar{D}_{\alpha}^{-1}\bar{E}_{\alpha})_{\sigma(t)} v_{\alpha} \\ \quad + (\bar{D}_{\alpha}^{-1}\bar{N}_{\alpha})_{\sigma(t)} y \end{cases}$$

with the initial condition $z(t_0) = x_0$. For each particular mode, the matrices $\bar{C}_{\alpha}, \bar{D}_{\alpha}, \bar{E}_{\alpha}, \bar{N}_{\alpha}$ are obtained similarly as explained in Section II-A. The notation $(\cdot)_{\sigma}$ denotes the object in the parenthesis calculated for the subsystem with index $\sigma(t)$. The initial condition $\sigma(t_0)$ determines the initial active subsystem at the initial time t_0 , from which time onwards, the active subsystem indexes and the input as well as the state are determined uniquely and simultaneously.

⁴An algebraic characterization of conditions under which a switched linear system is left invertible appears in [24, Lemma 3].

Remark 1: Ideally, for hard fault detection, one may only be interested in knowing whether any mode in \mathcal{F} is active, and not necessarily the exact value of the switching signal at all times. But note that the value of state trajectory is required to determine the transition between modes, and the state trajectory can only be simulated if the exact value of the switching signal is known. However, to find relaxed conditions for hard fault detection without requiring the exact knowledge of state trajectories is a topic of ongoing research. Another similar direction of future work is to find less restrictive conditions which allow us to detect nonzero values of the unknown inputs induced by soft faults without necessarily recovering the unknown input exactly. \triangleleft

3) *Example 3:* Consider again the circuit in Fig. 1 with the same assumptions as in Example 2, which resulted in (10)–(12). In this case, mode detection is possible since

$$\mathbf{N}_1 = \mathbf{N}_2 = \mathbf{N}_3 = \begin{bmatrix} 1 & 0 \\ 0 & 1 \\ \frac{d}{dt} & 0 \end{bmatrix}$$

$$J_1\nu_1 = J_2\nu_2 = J_3\nu_3 = \begin{bmatrix} 0 & 0 \\ 0 & 0 \\ \frac{1}{L} & 0 \end{bmatrix} \begin{bmatrix} v_s \\ i_{\text{load}} \end{bmatrix}$$

$$L_1 = \begin{bmatrix} 1 & 0 \\ 0 & 1 \\ -\frac{R_1 R_2}{(R_1 + R_2)L} & -\frac{1}{L} \end{bmatrix}, \quad L_2 = \begin{bmatrix} 1 & 0 \\ 0 & 1 \\ -\frac{R_1}{L} & -\frac{1}{L} \end{bmatrix}$$

$$L_3 = \begin{bmatrix} 1 & 0 \\ 0 & 1 \\ -\frac{R_2}{L} & -\frac{1}{L} \end{bmatrix}$$

and $\hat{\mathcal{Y}}_1 = \{y | \dot{y}_1 + (1/L)y_2 + (R_1 R_2 / (R_1 + R_2)L)y_1 = (1/L)v_s\}$, $\hat{\mathcal{Y}}_2 = \{y | \dot{y}_1 + (1/L)y_2 + (R_1/L)y_1 = (1/L)v_s\}$, $\hat{\mathcal{Y}}_3 = \{y | \dot{y}_1 + (1/L)y_2 + (R_2/L)y_1 = (1/L)v_s\}$. If $y_1(t) = i_L(t) = 0$ for some t , then $\dot{y}_1(t) = -(1/L)y_2(t) + (1/L)v_s(t)$, so that for each $y_{[t, t+\varepsilon)}$ contained in $\hat{\mathcal{Y}}_1$, $\hat{\mathcal{Y}}_2$, or $\hat{\mathcal{Y}}_3$, we must have $\dot{y}_1 = 0$, implying that $y_{[t, t+\varepsilon)} \in \cap_{i=1}^3 \hat{\mathcal{Y}}_i$. Further, the expressions for $L_i, J_i, \mathbf{N}_i, i = 1, 2, 3$, suggest that the mode cannot be identified using the index inversion function in (14). Conversely, if $i_L \neq 0$ at any time, then the mode can always be recovered using (14). It follows that there are no switch-singular pairs as long as i_L is not identically zero. Therefore the occurrence of a fault in either R_1 or R_2 can be detected. However, if $R_1 = R_2$, even if a fault in either R_1 or R_2 can be detected, it cannot be isolated, i.e., we cannot determine whether the fault occurred in R_1 or R_2 . Thus, in this example, isolation of hard faults is only possible if and only if $R_1 \neq R_2$. Inversion of the individual subsystems is also possible and $\phi(t)$ is given by

$$\phi(t) = \dot{y}_2 - \begin{bmatrix} \frac{1}{C} & 0 \end{bmatrix} \begin{bmatrix} i_L \\ v_C \end{bmatrix} + \frac{1}{C} i_{\text{load}}.$$

and therefore the detection of soft faults in the capacitor is also possible. It is important to note that $\phi(t) = (-\lambda_C(t)/(C(C + \lambda_C(t))))(i_L - i_{\text{load}})$, and since everything is known except $\lambda_C(t)$, which happens to be proportional to the magnitude of the fault, recovering $\phi(t)$ gives a measure of the component degradation.

Let us assume now that apart from the measurements of both states, only v_s is known, while i_{load} is unknown, so that $v = v_s$,

and $u = [i_{\text{load}} \ \phi]'$. In this case, mode identification is possible since

$$\mathbf{N}_1 = \mathbf{N}_2 = \mathbf{N}_3 = \begin{bmatrix} 1 & 0 \\ 0 & 1 \\ \frac{d}{dt} & 0 \end{bmatrix}$$

$$J_1\nu_1 = J_2\nu_2 = J_3\nu_3 = \begin{bmatrix} 0 \\ 0 \\ \frac{1}{L} \end{bmatrix} v_s$$

$$L_1 = \begin{bmatrix} 1 & 0 \\ 0 & 1 \\ -\frac{R_1 R_2}{(R_1 + R_2)L} & -\frac{1}{L} \end{bmatrix}$$

$$L_2 = \begin{bmatrix} 1 & 0 \\ 0 & 1 \\ -\frac{R_1}{L} & -\frac{1}{L} \end{bmatrix}, \quad L_3 = \begin{bmatrix} 1 & 0 \\ 0 & 1 \\ -\frac{R_2}{L} & -\frac{1}{L} \end{bmatrix}$$

and $\hat{\mathcal{Y}}_1, \hat{\mathcal{Y}}_2, \hat{\mathcal{Y}}_3$ remain unchanged. However, inversion of the individual subsystems is not possible as, by taking derivatives of the outputs, we get

$$\begin{bmatrix} \dot{y}_2 \\ \dot{y}_1 \end{bmatrix} = \begin{bmatrix} \frac{1}{C} & 0 \\ \frac{R^2}{L^2} - \frac{1}{LC} & \frac{R}{L^2} \end{bmatrix} \begin{bmatrix} i_L \\ v_C \end{bmatrix} + \begin{bmatrix} -\frac{1}{C} & 1 \\ \frac{1}{LC} & -\frac{1}{L} \end{bmatrix} \begin{bmatrix} i_{\text{load}} \\ \phi \end{bmatrix} + \begin{bmatrix} 0 \\ \frac{R}{L^2} \end{bmatrix} v_s$$

and since the matrix multiplying $[i_{\text{load}} \ \phi]'$ is not invertible, it is not possible to uniquely recover ϕ .

Finally, let us assume that apart from the measurements of both states, only i_{load} is known, while v_s is unknown. In this case, $\mathbf{N}_1 = \mathbf{N}_2 = \mathbf{N}_3 = I_{2 \times 2}$, $J_1 = J_2 = J_3 = 0_{2 \times 2}$, $L_1 = L_2 = L_3 = I_{2 \times 2}$. The operators in this case are of dimension lower than the previous two cases because the first derivative of each output is affected by a different unknown input. Since the system now has two unknown inputs and two outputs, $\hat{\mathcal{Y}}_1, \hat{\mathcal{Y}}_2, \hat{\mathcal{Y}}_3$ consists of set of differentiable outputs. Thus, it is not possible to do mode identification, and therefore hard faults in resistors will go undetected. In terms of soft faults in the capacitor, it is still possible to detect them even if it is not possible to detect the mode as for all $p = 1, 2, 3$, it results that

$$\phi(t) = \dot{y}_2 - \begin{bmatrix} \frac{1}{C} & 0 \end{bmatrix} \begin{bmatrix} i_L \\ v_C \end{bmatrix} + \frac{1}{C} i_{\text{load}}.$$

This is not true in general, i.e., the expression for inverting each subsystem is usually different, so to detect and isolate soft faults, it is necessary to identify the mode in which the system is operating. \triangleleft

IV. ANALYTICAL CASE-STUDIES

In this section, the application of the framework developed in Section III is illustrated by analyzing several power electronics circuits. Due to temperature variations, very high frequencies, and other variable conditions at which power electronics systems operate, the parameters of the components that comprise these systems may drift away over time from their nominal value. In this regard, we consider soft faults in capacitors and inductors and analyze how these faults affect typical power electronics circuits such as boost, buck, and boost-buck, and the conditions under which these faults can be detected and isolated in these circuits. We leave the illustration of hard fault

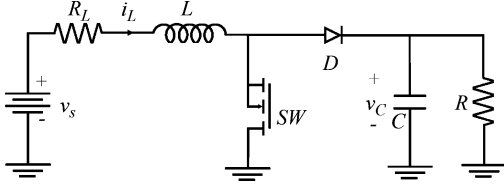

Fig. 2. Boost converter.

detection to the simulation examples of Section V. It is important to note that both hard and soft faults may cause performance degradation if not detected and accounted for. Although not discussed in this paper, the system controller could be reconfigured to account for these variations so as to maintain a prescribed level of performance.

A. Boost Converter

Consider the boost converter of Fig. 2 where we assume both i_L and v_C can be measured, and the voltage v_s is perfectly known. Let $x = [i_L \ v_C]'$, then the two modes of operation of this converter are

$$\Gamma_1 : \begin{cases} \dot{x} = \begin{bmatrix} -\frac{R_L}{L} & 0 \\ 0 & -\frac{1}{RC} \end{bmatrix} x + \begin{bmatrix} \frac{1}{L} \\ 0 \end{bmatrix} v_s \\ y = \begin{bmatrix} 1 & 0 \\ 0 & 1 \end{bmatrix} x \end{cases} \quad (15)$$

which corresponds to the case when SW is closed and D is open, and

$$\Gamma_2 : \begin{cases} \dot{x} = \begin{bmatrix} -\frac{R_L}{L} & -\frac{1}{L} \\ \frac{1}{C} & -\frac{1}{RC} \end{bmatrix} x + \begin{bmatrix} \frac{1}{L} \\ 0 \end{bmatrix} v_s \\ y = \begin{bmatrix} 1 & 0 \\ 0 & 1 \end{bmatrix} x \end{cases} \quad (16)$$

which corresponds to the case when SW is open, the diode D is conducting. We will assume that the switching signal is not available to the FDI system.

1) *Capacitor Soft Faults*: We can assume that as the capacitor degrades, its capacitance will decrease. Thus, without loss of generality, the capacitance of the capacitor can be described as $C(t) = C + \lambda_C(t)$, where C is the nominal capacitance, with $\lambda_C(t) \leq 0$ describing the fault magnitude. Then, the system dynamics can be described in a more general form to account for this fault as follows:

$$\Gamma_1 : \begin{cases} \dot{x} = \begin{bmatrix} -\frac{R_L}{L} & 0 \\ 0 & -\frac{1}{RC} + \rho_C(t) \end{bmatrix} x + \begin{bmatrix} \frac{1}{L} \\ 0 \end{bmatrix} v_s \\ y = \begin{bmatrix} 1 & 0 \\ 0 & 1 \end{bmatrix} x \end{cases} \quad (17)$$

where $\rho_C(t) = (1/C + \lambda_C(t))((\lambda_C(t)/RC) - d\lambda_C(t)/dt)$, and

$$\Gamma_2 : \begin{cases} \dot{x} = \begin{bmatrix} -\frac{R_L}{L} & -\frac{1}{L} \\ \frac{1}{C} + \mu_C(t) & -\frac{1}{RC} + \rho_C(t) \end{bmatrix} x + \begin{bmatrix} \frac{1}{L} \\ 0 \end{bmatrix} v_s \\ y = \begin{bmatrix} 1 & 0 \\ 0 & 1 \end{bmatrix} x \end{cases} \quad (18)$$

where $\mu_C(t) = -\lambda_C(t)/(C(C + \lambda_C(t)))$. Define ϕ_C as

$$\phi_C(t) := \begin{cases} \rho_C(t)v_C(t), & \text{if } \sigma(t) = 1 \\ \mu_C(t)i_L(t) + \rho_C(t)v_C(t), & \text{if } \sigma(t) = 2. \end{cases} \quad (19)$$

Then (17) and (18) can be rewritten as

$$\Gamma_1 : \begin{cases} \dot{x} = \begin{bmatrix} -\frac{R_L}{L} & 0 \\ 0 & -\frac{1}{RC} \end{bmatrix} x + \begin{bmatrix} \frac{1}{L} \\ 0 \end{bmatrix} v_s + \begin{bmatrix} 0 \\ 1 \end{bmatrix} \phi_C(t) \\ y = \begin{bmatrix} 1 & 0 \\ 0 & 1 \end{bmatrix} x \end{cases} \quad (20)$$

$$\Gamma_2 : \begin{cases} \dot{x} = \begin{bmatrix} -\frac{R_L}{L} & -\frac{1}{L} \\ \frac{1}{C} & -\frac{1}{RC} \end{bmatrix} x + \begin{bmatrix} \frac{1}{L} \\ 0 \end{bmatrix} v_s + \begin{bmatrix} 0 \\ 1 \end{bmatrix} \phi_C(t) \\ y = \begin{bmatrix} 1 & 0 \\ 0 & 1 \end{bmatrix} x. \end{cases} \quad (21)$$

Note that $\phi_C(t)$ basically represents the unknown degradation in the value of the capacitor. We now use the tools from Section III to recover the switching signal $\sigma(t)$ and the unknown function $\phi_C(t)$. It is important to note that there might be cases in which the switching signal is available to the fault detection and isolation system, in which case, it would only be necessary to recover $\phi_C(t)$.

2) *Mode Identification*: Following the notation used in Section III, it results that the operators $N_1, N_2, J_1, J_2, L_1, L_2$ are

$$N_1 = N_2 = \begin{bmatrix} 1 & 0 \\ 0 & 1 \\ \frac{d}{dt} & 0 \end{bmatrix}, \quad J_1\nu_1 = J_2\nu_2 = \begin{bmatrix} 0 \\ 0 \\ \frac{1}{L} \end{bmatrix} v_s$$

$$L_1 = \begin{bmatrix} 1 & 0 \\ 0 & 1 \\ -\frac{R_L}{L} & 0 \end{bmatrix}, \quad L_2 = \begin{bmatrix} 1 & 0 \\ 0 & 1 \\ -\frac{R_L}{L} & -\frac{1}{L} \end{bmatrix}.$$

Also, $\hat{Y}_1 = \{y | \dot{y}_1 + (R_L/L)y_1 = (1/L)v_s\}$, and $\hat{Y}_2 = \{y | \dot{y}_1 + (1/L)\dot{y}_2 + (R_L/L)\dot{y}_1 = (1/L)\dot{v}_s\}$. The active mode can then be identified using (8), and the only possibility of switch-singular pair is if $-(R_L/L)i_L(t) = -(R_L/L)i_L - (1/L)v_C(t)$, or equivalently $v_C(t) = 0$. Thus, if the original system has switching when $v_C(t) = 0$, then it would not be observable in the output and in that case $\sigma(t)$ cannot be recovered uniquely.⁵ However, this would mean that the voltage across the load becomes zero, which is not possible without a large variation on the capacitance; but before this occurs, since the capacitor degrades gracefully, the voltage $v_C(t)$ will remain greater than zero and therefore, the existence of a switch-singular pair is ruled out. Thus, other than the particular case described, the switching signal can be recovered using the following formula:

$$\sigma(t) = \begin{cases} 1, & \text{if } y_{[t, t+\varepsilon)} \in \hat{Y}_1 \text{ and } N_1 y(t) = L_1 x(t) + J_1 v_s(t) \\ 2, & \text{if } y_{[t, t+\varepsilon)} \in \hat{Y}_2 \text{ and } N_2 y(t) = L_2 x(t) + J_2 v_s(t). \end{cases} \quad (22)$$

⁵To recover non-unique switching signals in the presence of switch-singular pairs, see the algorithm proposed in [24]. A conceptually similar algorithm tailored for FDI framework appears in Section V. It must be noted that these algorithms are non-causal and require the knowledge of future outputs to recover the value of switching signal in the past.

Having recovered the switching signal $\sigma(t)$, one can activate the corresponding inverse subsystem to compute $\phi_C(t)$ and hence the change in the nominal value of the capacitor.

3) *Unknown Input Recovery*: In this case, both subsystems are invertible, so the detection and isolation of capacitor soft faults is possible. Applying the structure algorithm to Γ_1 and differentiating the output, we obtain

$$\dot{y} = \begin{bmatrix} -\frac{R_L}{L} & 0 \\ 0 & -\frac{1}{RC} \end{bmatrix} x + \begin{bmatrix} \frac{1}{L} \\ 0 \end{bmatrix} v_s + \begin{bmatrix} 0 \\ 1 \end{bmatrix} \phi_C(t)$$

from where it follows that $S_1 = I$ and therefore $D_1 = [0 \ 1]'$. Furthermore, $q_1 = \text{rank}(D_1) = 1$, which is equal to the dimension of the input space and thus $q_\alpha = q_1$. Then following the notation used in Section III, it results that $\bar{N}_\alpha = [0 \ d/dt]$, $\bar{C}_\alpha = [0 \ -1/(RC)]$, and $\bar{D}_\alpha = 1$; hence the inverse system is described by

$$\Gamma_1^{-1} : \begin{cases} \bar{y}_\alpha = [0 \ \frac{d}{dt}] y, \\ \dot{z} = \begin{bmatrix} -\frac{R_L}{L} & 0 \\ 0 & 0 \end{bmatrix} z + \begin{bmatrix} \frac{1}{L} \\ 0 \end{bmatrix} v_s + \bar{y}_\alpha \\ \phi_C = [0 \ \frac{1}{RC}] z + \bar{y}_\alpha. \end{cases} \quad (23)$$

The similar procedure can be applied to Γ_2 to get dynamic representations for Γ_2^{-1}

$$\Gamma_2^{-1} : \begin{cases} \bar{y}_\alpha = [0 \ \frac{d}{dt}] y \\ \dot{z} = \begin{bmatrix} -\frac{R_L}{L} & -\frac{1}{L} \\ 0 & 0 \end{bmatrix} z + \begin{bmatrix} \frac{1}{L} \\ 0 \end{bmatrix} v_s + \bar{y}_\alpha \\ \phi_C = [-\frac{1}{C} \ \frac{1}{RC}] z + \bar{y}_\alpha. \end{cases} \quad (24)$$

The inverse switched system, comprising of these inverse subsystems, produces ϕ_C as an output provided the initial condition is $z(t_0) = x(t_0)$.

4) *Inductance Soft Faults*: Following the same procedure as in the case of capacitor faults, the variation of the inductance over time can be described by $L(t) = L + \lambda_L(t)$, and the system dynamics is then given by

$$\Gamma_1 : \begin{cases} \dot{x} = \begin{bmatrix} -\frac{R_L}{L} & 0 \\ 0 & -\frac{1}{RC} \end{bmatrix} x + \begin{bmatrix} \frac{1}{L} \\ 0 \end{bmatrix} v_s + \begin{bmatrix} 1 \\ 0 \end{bmatrix} \phi_L(t) \\ y = \begin{bmatrix} 1 & 0 \\ 0 & 1 \end{bmatrix} x \end{cases} \quad (25)$$

$$\Gamma_2 : \begin{cases} \dot{x} = \begin{bmatrix} -\frac{R_L}{L} & -\frac{1}{L} \\ \frac{1}{C} & -\frac{1}{RC} \end{bmatrix} x + \begin{bmatrix} \frac{1}{L} \\ 0 \end{bmatrix} v_s + \begin{bmatrix} 1 \\ 0 \end{bmatrix} \phi_L(t) \\ y = \begin{bmatrix} 1 & 0 \\ 0 & 1 \end{bmatrix} x \end{cases} \quad (26)$$

where the expression for $\phi_L(t)$ is given by (27), shown at the bottom of the page.

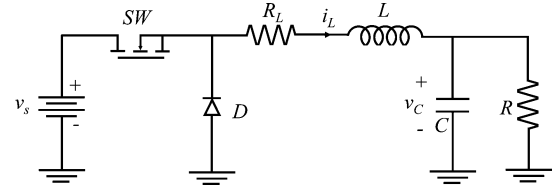

Fig. 3. Buck converter.

5) *Mode Identification*: Following the notion used in Section III, it results that the operators $\mathbf{N}_1, \mathbf{N}_2, J_1, J_2, L_1, L_2$ are

$$\mathbf{N}_1 = \mathbf{N}_2 = \begin{bmatrix} 1 & 0 \\ 0 & 1 \\ 0 & \frac{d}{dt} \end{bmatrix}, \quad J_1 = J_2 = 0$$

$$L_1 = \begin{bmatrix} 1 & 0 \\ 0 & 1 \\ 0 & -\frac{1}{RC} \end{bmatrix}, \quad L_2 = \begin{bmatrix} 1 & 0 \\ 0 & 1 \\ \frac{1}{C} & -\frac{1}{RC} \end{bmatrix}.$$

Also, $\hat{\mathcal{Y}}_1 = \{y \mid \dot{y}_2 + (1/(RC))y_2 = 0\}$, and $\hat{\mathcal{Y}}_2 = \{y \mid \dot{y}_2 + (1/C)\dot{y}_1 + (1/(RC))\dot{y}_2 = 0\}$. Note that $\hat{\mathcal{Y}}_1 \subseteq \hat{\mathcal{Y}}_2$, so the mode identification can only be carried out using (8) and the switch-singular pairs exist when $i_L = 0$, but this is only possible in discontinuous conduction mode (DCM), and before DCM is reached, i_L will remain greater than zero for certain amount of time, so it is possible to recover the unknown input and therefore identify the fault. Thus, other than this case, the switching signal can be recovered by using

$$\sigma(t) = \begin{cases} 1, & \text{if } y_{[t, t+\varepsilon)} \in \hat{\mathcal{Y}}_1 \text{ and } \mathbf{N}_1 y(t) = L_1 x(t) \\ 2 & \text{if } y_{[t, t+\varepsilon)} \in \hat{\mathcal{Y}}_2 \text{ and } \mathbf{N}_2 y(t) = L_2 x(t). \end{cases} \quad (28)$$

6) *Unknown Input Recovery*: In this case, both subsystems are also invertible, so the detection and isolation of inductor soft faults is possible. The inverse subsystems are described by

$$\Gamma_1^{-1} : \begin{cases} \bar{y}_\alpha = [\frac{d}{dt} \ 0] y \\ \dot{z} = \begin{bmatrix} 0 & 0 \\ 0 & -\frac{1}{RC} \end{bmatrix} z + \bar{y}_\alpha \\ \phi_L = [\frac{R_L}{L} \ 0] z - \frac{1}{L} v_s + \bar{y}_\alpha \end{cases} \quad (29)$$

and

$$\Gamma_2^{-1} : \begin{cases} \bar{y}_\alpha = [\frac{d}{dt} \ 0] y \\ \dot{z} = \begin{bmatrix} 0 & 0 \\ \frac{1}{C} & -\frac{1}{RC} \end{bmatrix} z + \bar{y}_\alpha \\ \phi_L = [\frac{R_L}{L} \ \frac{1}{L}] z - \frac{1}{L} v_s + \bar{y}_\alpha. \end{cases} \quad (30)$$

B. Buck Converter

Consider the buck converter of Fig. 3 where we assume both i_L and v_C can be measured, and the voltage v_s is perfectly known. Let $x = [i_L \ v_C]'$. The case of capacitance soft-faults is

$$\phi_L(t) := \begin{cases} \frac{1}{L + \lambda_L(t)} \left(\left(\frac{R_L}{L} \lambda_L(t) - \frac{d\lambda_L(t)}{dt} \right) i_L - \frac{\lambda_L(t)}{L} v_s \right), & \text{if } \sigma(t) = 1 \\ \frac{1}{L + \lambda_L(t)} \left(\left(\frac{R_L}{L} \lambda_L(t) - \frac{d\lambda_L(t)}{dt} \right) i_L + \frac{\lambda_L(t)}{L} (v_C - v_s) \right), & \text{if } \sigma(t) = 2 \end{cases} \quad (27)$$

similar to the boost converter case, so we omit the analysis and we focus on the more interesting case of inductor soft faults.

1) *Inductor Soft Faults*: Assuming as before that the inductance variation over time can be described by $L(t) = L + \lambda_L(t)$, the converter dynamics are described by

$$\Gamma_1 : \begin{cases} \dot{x} = \begin{bmatrix} -\frac{R_L}{L} & -\frac{1}{L} \\ \frac{1}{C} & -\frac{1}{RC} \end{bmatrix} x + \begin{bmatrix} \frac{1}{L} \\ 0 \end{bmatrix} v_s + \begin{bmatrix} 1 \\ 0 \end{bmatrix} \phi_L(t) \\ y = \begin{bmatrix} 1 & 0 \\ 0 & 1 \end{bmatrix} x \end{cases} \quad (31)$$

and

$$\Gamma_2 : \begin{cases} \dot{x} = \begin{bmatrix} -\frac{R_L}{L} & -\frac{1}{L} \\ \frac{1}{C} & -\frac{1}{RC} \end{bmatrix} x + \begin{bmatrix} 1 \\ 0 \end{bmatrix} \phi_L(t) \\ y = \begin{bmatrix} 1 & 0 \\ 0 & 1 \end{bmatrix} x \end{cases} \quad (32)$$

where the expression for $\phi_L(t)$ appears in the equation at the bottom of the page. So to recover the value of $\phi_L(t)$, one must first recover the switching signal using (14).

For subsystems (31), (32), the operators involved in mode identification are: $J_1 = J_2 = 0$, and

$$\mathbf{N}_1 = \mathbf{N}_2 = \begin{bmatrix} 1 & 0 \\ 0 & 1 \\ 0 & \frac{d}{dt} \end{bmatrix}, \quad L_1 = L_2 = \begin{bmatrix} 1 & 0 \\ 0 & 1 \\ \frac{1}{C} & -\frac{1}{RC} \end{bmatrix}$$

and $\hat{y}_1 = \hat{y}_2 = \{y | \dot{y}_2 - (1/C)\dot{y}_1 + (1/(RC))\dot{y}_2 = 0\}$. Since for any output produced by the system it is true that either $\mathbf{N}_1 y = L_1 x$ or $\mathbf{N}_2 y = L_2 x$, it follows that the equality in (7) always holds. In other words, every output produced by the switched system forms a switch-singular pair and the mode detection is not possible in this case. Since the recovery of the mode is the first step in the recovery of the unknown signal $\phi_L(t)$, it is not possible to detect the faults in the inductor using this approach. If the switching signal were already available to the FDI system, then we could bypass this problem and it would be possible to recover the unknown disturbance introduced by the inductance soft faults. The corresponding inverse subsystems would be described by

$$\Gamma_1^{-1} = \begin{cases} \bar{y}_\alpha = \begin{bmatrix} \frac{d}{dt} & 0 \end{bmatrix} y \\ \dot{z} = \begin{bmatrix} 0 & 0 \\ \frac{1}{C} & -\frac{1}{RC} \end{bmatrix} z + \bar{y}_\alpha \\ \phi_L = \begin{bmatrix} \frac{R_L}{L} & \frac{1}{L} \end{bmatrix} z - \frac{1}{L} v_s + \bar{y}_\alpha \end{cases} \quad (33)$$

and

$$\Gamma_2^{-1} = \begin{cases} \bar{y}_\alpha = \begin{bmatrix} \frac{d}{dt} & 0 \end{bmatrix} y \\ \dot{z} = \begin{bmatrix} 0 & 0 \\ \frac{1}{C} & -\frac{1}{RC} \end{bmatrix} z + \bar{y}_\alpha \\ \phi_L = \begin{bmatrix} \frac{R_L}{L} & \frac{1}{L} \end{bmatrix} z + \bar{y}_\alpha. \end{cases} \quad (34)$$

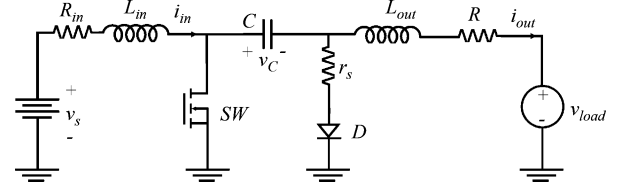

Fig. 4. Boost-buck converter.

C. Boost-Buck Converter

Consider a boost-buck converter given in Fig. 4, the dynamics of which are governed by

$$\Gamma_1 : \begin{cases} \frac{dx}{dt} = \begin{bmatrix} -\frac{R_{in}+r_s}{L_{in}} & \frac{r_s}{L_{in}} & -\frac{1}{L_{in}} \\ \frac{r_s}{L_{out}} & -\frac{(R+r_s)}{L_{out}} & 0 \\ \frac{1}{C} & 0 & 0 \end{bmatrix} x + \begin{bmatrix} \frac{1}{L_{in}} \\ 0 \\ 0 \end{bmatrix} v_s \\ + \begin{bmatrix} 0 \\ -\frac{1}{L_{out}} \\ 0 \end{bmatrix} v_{load} \\ y = x \end{cases} \quad (35)$$

and

$$\Gamma_2 : \begin{cases} \frac{dx}{dt} = \begin{bmatrix} -\frac{R_{in}}{L_{in}} & 0 & 0 \\ 0 & -\frac{R}{L_{out}} & -\frac{1}{L_{out}} \\ 0 & \frac{1}{C} & 0 \end{bmatrix} x + \begin{bmatrix} \frac{1}{L_{in}} \\ 0 \\ 0 \end{bmatrix} v_s \\ + \begin{bmatrix} 0 \\ -\frac{1}{L_{out}} \\ 0 \end{bmatrix} v_{load} \\ y = x \end{cases} \quad (36)$$

where $x = [i_{in} \ i_{out} \ v_C]^T$. We assume that the switching signal and the load voltage v_{load} are both unknown and that measurements of all state variables are available. In the absence of faults, it is possible to recover both the switching signal and v_{load} . We show that in the presence of soft faults in L_{in} or C , it is still possible to recover the unknown input v_{load} as well as the input disturbance introduced by the corresponding soft fault. In contrast, in the presence of soft faults in L_{out} , it is not possible to recover both v_{load} and the input disturbance introduced by the fault. We just discuss the case of capacitor soft faults as the case of soft faults in L_{in} is very similar.

1) *Capacitor Soft Faults*: Introducing the faults as in previous examples, it follows that

$$\Gamma_1 : \begin{cases} \frac{dx}{dt} = \begin{bmatrix} -\frac{(R_{in}+r_s)}{L_{in}} & \frac{r_s}{L_{in}} & -\frac{1}{L_{in}} \\ \frac{r_s}{L_{out}} & -\frac{(R+r_s)}{L_{out}} & 0 \\ \frac{1}{C} & 0 & 0 \end{bmatrix} x \\ + \begin{bmatrix} \frac{1}{L_{in}} \\ 0 \\ 0 \end{bmatrix} v_s + \begin{bmatrix} 0 & 0 \\ -\frac{1}{L_{out}} & 0 \\ 0 & 1 \end{bmatrix} \begin{bmatrix} v_{load} \\ \phi_C \end{bmatrix} \\ y = x \end{cases} \quad (37)$$

$$\phi_L(t) = \begin{cases} \frac{1}{L+\lambda_L(t)} \left(\left(\frac{R_L}{L} \lambda_L(t) - \frac{d\lambda_L(t)}{dt} \right) i_L + \frac{\lambda_L(t)}{L} (v_C - v_s) \right), & \text{if } \sigma(t) = 1 \\ \frac{1}{L+\lambda_L(t)} \left(\left(\frac{R_L}{L} \lambda_L(t) - \frac{d\lambda_L(t)}{dt} \right) i_L + \frac{\lambda_L(t)}{L} v_C \right), & \text{if } \sigma(t) = 2 \end{cases}$$

and

$$\Gamma_2 : \begin{cases} \frac{dx}{dt} = \begin{bmatrix} -\frac{R_{in}}{L_{in}} & 0 & 0 \\ 0 & -\frac{R}{L_{out}} & -\frac{1}{L_{out}} \\ 0 & \frac{1}{C} & 0 \end{bmatrix} x + \begin{bmatrix} \frac{1}{L_{in}} \\ 0 \\ 0 \end{bmatrix} v_s \\ + \begin{bmatrix} 0 & 0 \\ -\frac{1}{L_{out}} & 0 \\ 0 & 1 \end{bmatrix} \begin{bmatrix} v_{load} \\ \phi_C \end{bmatrix} \\ y = x \end{cases} \quad (38)$$

where

$$\phi_C(t) = \begin{cases} \frac{1}{C+\lambda_C(t)} \left(\frac{\lambda_C(t)}{C} i_{in} - \frac{d\lambda_C(t)}{dt} v_C \right), & \text{if } \sigma(t) = 1 \\ \frac{1}{C+\lambda_C(t)} \left(\frac{\lambda_C(t)}{C} i_{out} - \frac{d\lambda_C(t)}{dt} v_C \right), & \text{if } \sigma(t) = 2. \end{cases}$$

2) *Mode Identification*: Applying the structure algorithm to each subsystem, we obtain

$$\begin{aligned} N_1 = N_2 &= \begin{bmatrix} I_{3 \times 3} \\ d/dt & 0 & 0 \end{bmatrix} \\ L_1 &= \begin{bmatrix} I_{3 \times 3} \\ -(R_{in} + r_s)/L_{in} & r_s/L_{in} & -1/L_{in} \end{bmatrix} \\ L_2 &= \begin{bmatrix} I_{3 \times 3} \\ -R_{in}/L_{in} & 0 & 0 \end{bmatrix} \\ J_1 = J_2 &= \begin{bmatrix} 0_{3 \times 1} \\ 1/L_{in} \end{bmatrix} \end{aligned}$$

and $\hat{Y}_1 = \{y | \dot{y}_1 - (r_s/L_{in})\dot{y}_2 + (1/L_{in})\dot{y}_3 + ((R_{in} + r_s)/L_{in})\dot{y}_1 = (1/L_{in})\dot{v}_s\}$, $\hat{Y}_2 = \{y | \dot{y}_1 + (R_{in}/L_{in})y_1 = (1/L_{in})v_s\}$. Thus, the switching signal can be recovered in exactly the same manner as in (22).

3) *Unknown Input Recovery*: In this case, there are two unknown inputs to be recovered, the load voltage v_{load} and the input disturbance introduced by the capacitor soft fault. For each mode, the corresponding inverse subsystems are

$$\Gamma_1^{-1} : \begin{cases} \frac{dz}{dt} = \begin{bmatrix} -\frac{(R_{in}+r_s)}{L_{in}} & \frac{r_s}{L_{in}} & -\frac{1}{L_{in}} \\ 0 & 0 & 0 \\ 0 & 0 & 0 \end{bmatrix} z + \begin{bmatrix} \frac{1}{L_{in}} \\ 0 \\ 0 \end{bmatrix} v_s \\ + \begin{bmatrix} 0 & 0 \\ 1 & 0 \\ 0 & 1 \end{bmatrix} \begin{bmatrix} \dot{y}_2 \\ \dot{y}_3 \end{bmatrix} \\ \begin{bmatrix} v_{load} \\ \phi_C \end{bmatrix} = \begin{bmatrix} -L_{out} & 0 \\ 0 & 1 \end{bmatrix} \begin{bmatrix} \dot{y}_2 \\ \dot{y}_3 \end{bmatrix} \\ + \begin{bmatrix} r_s & -(R+r_s) \\ \frac{1}{C} & 0 \end{bmatrix} z \end{cases} \quad (39)$$

and

$$\Gamma_2^{-1} : \begin{cases} \frac{dz}{dt} = \begin{bmatrix} -\frac{R_{in}}{L_{in}} & 0 & 0 \\ 0 & 0 & 0 \\ 0 & 0 & 0 \end{bmatrix} z + \begin{bmatrix} \frac{1}{L_{in}} \\ 0 \\ 0 \end{bmatrix} v_s \\ + \begin{bmatrix} 0 & 0 \\ 1 & 0 \\ 0 & 1 \end{bmatrix} \begin{bmatrix} \dot{y}_2 \\ \dot{y}_3 \end{bmatrix} \\ \begin{bmatrix} v_{load} \\ \phi_C \end{bmatrix} = \begin{bmatrix} -L_{out} & 0 \\ 0 & 1 \end{bmatrix} \begin{bmatrix} \dot{y}_2 \\ \dot{y}_3 \end{bmatrix} \\ - \begin{bmatrix} 0 & R & 1 \\ 0 & \frac{1}{C} & 0 \end{bmatrix} z \end{cases} \quad (40)$$

with $z(t_0) = x(t_0)$.

V. COMPUTER IMPLEMENTATION AND SIMULATION RESULTS

In this section, we provide an algorithm amenable for computer implementation that automates the necessary tasks of FDI discussed in previous sections. The effectiveness of the algorithm to detect and isolate both hard and soft faults was tested in a computer simulation. In this regard, MATLAB/Simulink were used as the platform to implement the algorithm. The boost converter case-study presented in Section IV was simulated numerically using Simulink and PLECS [30], and random soft faults were injected in the simulation models to assess whether or not the algorithm implementation could successfully detect and isolate the corresponding injected faults. Additionally, a network of buck converters serving several loads was also simulated to test the effectiveness of the algorithm for detecting hard faults. The FDI algorithm was also successfully tested in boost-buck converter, although the results are not included.

Algorithm for Automatic FDI

Based upon the concepts introduced in Section III, we give an algorithm that takes the parameters $x_0 \in \mathbb{R}^n$, measured output y (defined over a finite interval) and returns the set \mathcal{A} , that contains the switching signal σ , the unknown inputs $u = [\mu \ \phi]'$, and the decision variables H_fault and S_fault that represent hard and soft faults respectively.

Since the occurrence of a hard fault is indicated by a switching signal taking values over a finite set, it is natural to associate a boolean decision variable for its detection. A soft fault on the other hand is related to a real valued signal ϕ , and it may be undesirable to take any action when the value of ϕ is considerably smaller. Therefore, we declare a soft fault only when ϕ has crossed certain threshold value, denoted by δ in the

Algorithm 1 Fault Detection and Isolation in Switched Linear Systems

```

begin FDI( $y_{[t_0, T]}$ ),  $x_0$ )
  Let  $\bar{\mathcal{P}} := \{p \in \mathcal{P} : y_{[t_0, t_0+\varepsilon)} \in \hat{\mathcal{Y}}_p \text{ for some } \varepsilon > 0\}$ .
  Let  $t^* := \min\{t \in [t_0, T) : y_{[t, t+\varepsilon)} \notin \hat{\mathcal{Y}}_p \text{ for some } p \in \bar{\mathcal{P}}, \varepsilon > 0\}$  otherwise  $t^* = T$ .
  Let  $\mathcal{P}^* := \Sigma^{-1}(x_0, y_{[t_0, t^*)})$ .
  if  $\mathcal{P}^* \neq \emptyset$  then
    Let  $\mathcal{A} := \emptyset$ 
    foreach  $p \in \mathcal{P}^*$ 
      if  $p \in \mathcal{F}$  then H_fault( $p$ ) = 1
      Let  $u = \Gamma_{p, x_0}^{-1, O}(y_{[t_0, t^*)})$ 
      if  $\|\phi(i)\| > \delta$  then S_fault( $i$ ) = 1
       $\mathcal{T} := \{t \in (t_0, t^*); (x(t), y_{[t, t^*)}) \text{ is a}$ 
       $\text{switch-singular pair of } \Gamma_p, \Gamma_q \text{ for some } q \neq p\}$ .
      if  $\mathcal{T}$  is a finite set
        foreach  $\tau \in \mathcal{T}$  do
          let  $\xi := \Gamma_p(u)(\tau)$ 
           $\mathcal{A} \leftarrow \mathcal{A} \cup \{(\sigma_{[t_0, \tau)}, u_{[t_0, \tau)}, \text{H\_fault}, \text{S\_fault})$ 
           $\oplus \text{start}(y_{[\tau, T)}, \xi)\}$ 
      else if  $\mathcal{T} = \emptyset$  and  $t^* < T$  then
        let  $\xi := \Gamma_p(u)(t^*)$ 
         $\mathcal{A} \leftarrow \mathcal{A} \cup \{(\sigma_{[t_0, t^*)}, u_{[t_0, t^*)}, \text{H\_fault}, \text{S\_fault})$ 
         $\oplus \text{start}(y_{[t^*, T)}, \xi)\}$ 

```

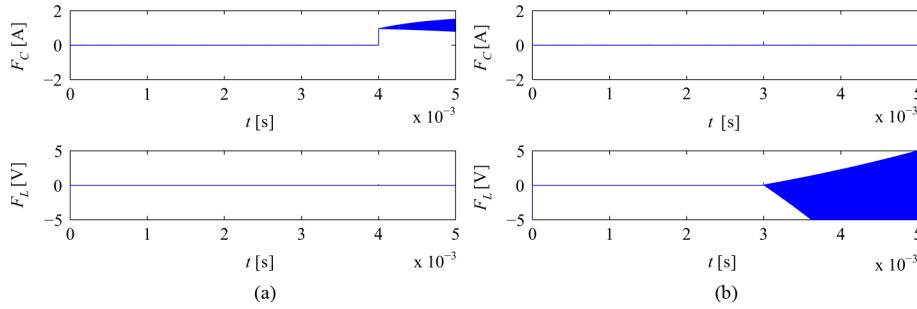

Fig. 5. Time evolution of boost converter capacitor fault flag F_C and inductor fault flag, F_L . (a) Fault flags for a capacitor soft fault starting at $t = 4 \cdot 10^{-3}$ s. (b) Fault flags for an inductor soft fault starting at $t = 3 \cdot 10^{-3}$ s.

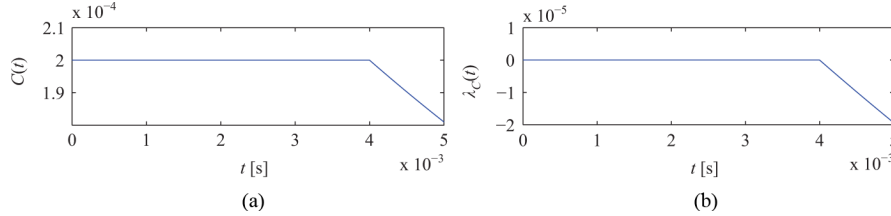

Fig. 6. Time varying capacitance and degradation from nominal value. (a) Actual value of capacitance. (b) Recovered soft fault in capacitor.

else if $\mathcal{T} = \emptyset$ and $t^* = T$ **then**

$\mathcal{A} \leftarrow \mathcal{A} \cup \{(\sigma_{[t_0, T]}, u_{[t_0, T]}), \text{H_fault}, \text{S_fault}\}$

else

$\mathcal{A} := \emptyset$

else

$\mathcal{A} := \emptyset$

end

algorithm. Now, H_fault (respectively, S_fault) is a vector and a value 1 in any of the entries indicates a hard (respectively, soft) fault in the corresponding component. In case of multiple faults or switch-singular pairs, these decision vectors can have multiple 1's. In the algorithm, $\Sigma^{-1}(x_0, y)$ denotes the index-inversion map which returns the indices of the modes that can produce the given output and thus it may be multi-valued. If the returned set is empty, no subsystem is able to generate that y starting from x_0 . The symbol \oplus is used for concatenation and by convention $S \oplus \emptyset = \emptyset$ for any set S . Further, $\Gamma_{p, x_0}^{-1, O}$ indicates the output of the inverse subsystem p when initialized at x_0 .

If the return is a non-empty set, the set must be finite and contains pairs of switching signals and inputs that generate the measured y starting from x_0 . If the return is an empty set, it means that there is no switching signal and input that generate y . This may be the case if the system is operating in a configuration/faulty mode which has not been modeled or there is an infinite number of possible switching times. Also by our concatenation notation: if at any instant of time, the return of the procedure is an empty set, then that branch of the search will be empty because $\eta \oplus \emptyset = \emptyset$.

A. Boost Converter

We show simulation results for the boost converter case-study discussed in Section IV-A, the parameter values of which are given in Table I. Note that although we are considering the converter that is operating in open-loop with a fixed duty ratio $D = 0.79$, the proposed FDI framework is independent of the type of control. Fig. 5 shows the time evolution of the capacitor

TABLE I
BOOST CONVERTER PARAMETER VALUES

R_L [Ω]	L [H]	C [F]	R [Ω]	v_s [V]	f [kHz]	D
0.2	$5 \cdot 10^{-5}$	$2 \cdot 10^{-4}$	24	12	$200 \cdot 10^3$	0.79

and inductor fault flags. For scaling purpose, we plot the capacitor fault flag $F_C = C\phi_C$, which is obtained by multiplying the nominal capacitance value and the input disturbance introduced by the capacitor soft fault (19). Similarly, the inductor fault flag $F_L = L\phi_L$ results from multiplying the nominal inductance value and the disturbance introduced by the inductor soft fault (27). Note that the fault flags F_C and F_L are indicators of soft faults and the actual error profile can be obtained by solving ODEs (19) and (27) for λ_C and λ_L , respectively. Fig. 6 shows the actual value of time varying capacitance $C(t) = C + \lambda_C(t)$, and the (recovered) value of $\lambda_C(t)$ obtained as a solution of (19). We choose to work with the fault flags instead of actual error profile because in some cases the underlying ODE solved to obtain λ_C or λ_L may be unstable and the small noise accumulated in the recovery of ϕ_C or ϕ_L may lead to inaccurate profiling of the error.

1) *Capacitor Soft Fault*: In the simulation, the capacitor is described by a time-varying capacitance

$$C(t) = \begin{cases} C, & \text{if } t < 4 \cdot 10^{-3} \text{ s} \\ C e^{-100(t-4 \cdot 10^{-3})}, & \text{if } t \geq 4 \cdot 10^{-3} \text{ s}. \end{cases} \quad (41)$$

Thus, this is equivalent to assuming that the capacitor remains fault-free up to $t = 4 \cdot 10^{-3}$ s and then it starts gracefully degrading, causing its capacitance to decrease. The FDI system captured this fault occurrence as it can be seen in Fig. 5(a), where the capacitor fault flag F_C remains zero until $t = 4 \cdot 10^{-3}$ s and then it suddenly jumps indicating the presence of the soft fault. It is important to note that inductor fault flag F_L remains at zero, which is consistent with the fact that no soft fault has occurred in the inductor. In Fig. 5(a), both F_C and F_L are curves oscillating at very high frequency, which is difficult

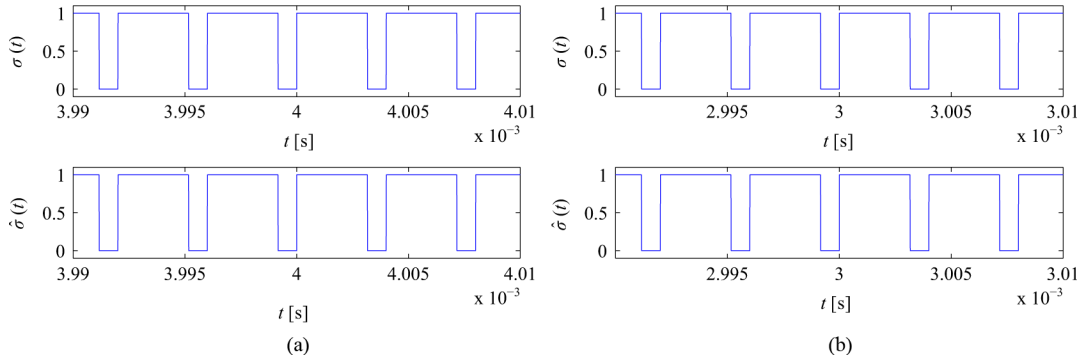

Fig. 7. Boost converter real switching signal $\sigma(t)$ and recovered version $\hat{\sigma}(t)$. (a) $\sigma(t)$ and $\hat{\sigma}(t)$ around the capacitor soft fault occurrence. (b) $\sigma(t)$ and $\hat{\sigma}(t)$ around the inductor soft fault occurrence.

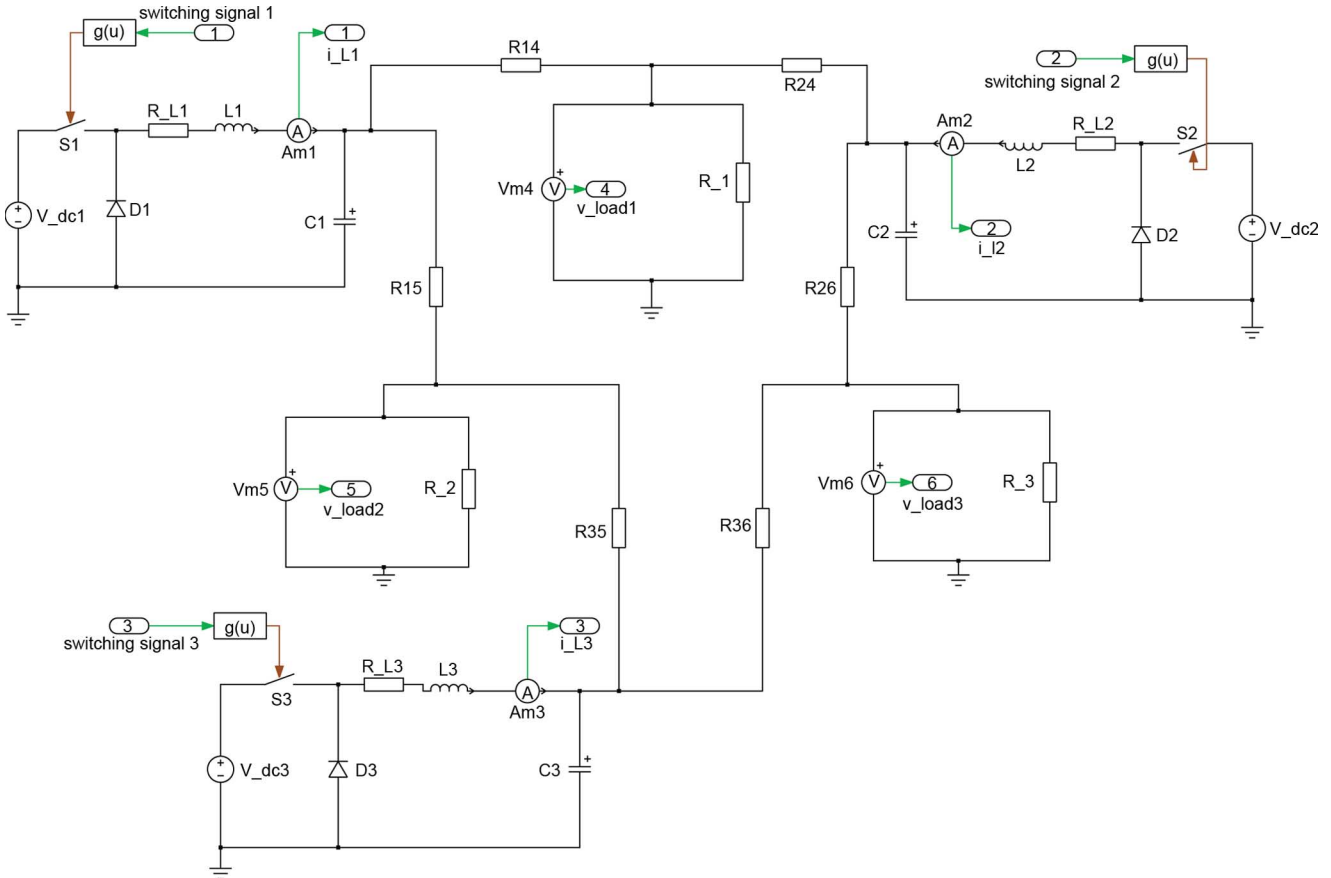

Fig. 8. DC network implementation in PLECS.

to observe at a first glance due to the time scale used in the representation. Also, the degradation time constant chosen in the example is 0.01 s. In reality, degradation time constants are much larger; however, we chose this value to make the fault occurrence apparent in Fig. 5(a). This is by no means a limitation of the FDI system, which should be able to detect degrading faults with slower constant, but a limitation of the way the results are displayed.

2) *Inductor Soft Fault*: Similarly, to model inductor soft faults, the inductance is described by

$$L(t) = \begin{cases} L, & \text{if } t < 3 \cdot 10^{-3} \text{ s} \\ Le^{-200(t-3 \cdot 10^{-3})}, & \text{if } t \geq 3 \cdot 10^{-3} \text{ s}. \end{cases} \quad (42)$$

As shown in Fig. 5(b), the FDI system captured this fault and at time $t = 3 \cdot 10^{-3}$ s, the inductor fault flag F_L starts drifting

from its previous zero value, indicating the presence of a soft fault in the inductor. As expected, the capacitor fault flag does not change after $3 \cdot 10^{-3}$ s.

3) *Mode Detection*: For completion, we show in Fig. 7 the real converter switching signal $\sigma(t)$, and the recovered switching signal $\hat{\sigma}(t)$ using the structure algorithm around the time of fault occurrence of both the capacitor and inductor. It is clear that the mode detection part, which is key for input recovery, works fine (consistent with the soft fault recovery results shown in Fig. 5).

B. DC Network

Consider the dc network of Fig. 8. The purpose of this system is to reliably provide dc power to three dispersed loads (described by resistors R_1 , R_2 , and R_3) in a reliable manner. In-

TABLE II
DC NETWORK PARAMETER VALUES, WHERE $i = 1, 2, 3$

R_{L_i} [Ω]	L_i [H]	C_i [F]	$R_{14(5)}, R_{24(6)}, R_{35(6)}$ [Ω]	V_i [V]	f [kHz]	D_i	R_1 [Ω]	R_2 [Ω]	R_3 [Ω]
0.1	$1.2 \cdot 10^{-5}$	$1.5 \cdot 10^{-3}$	0.01	12	$250 \cdot 10^3$	0.49	0.5	0.8	0.6

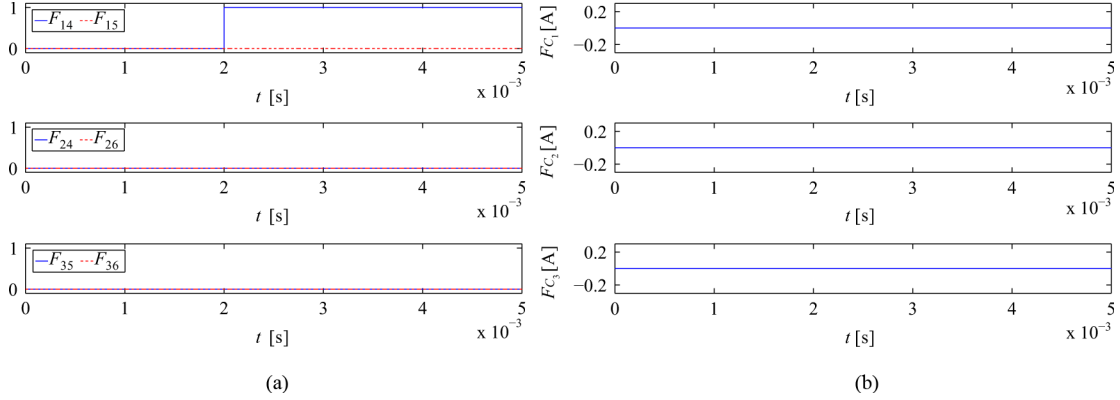

Fig. 9. Time evolution of dc network hard fault flags in transmission lines and soft fault flags in buck converter capacitors for a hard fault in transmission line R_{14} starting at $t = 2 \cdot 10^{-3}$. (a) Transmission line fault flags F_{14} , F_{15} , F_{24} , F_{26} , F_{35} , F_{36} . (b) Buck converter capacitor fault flags F_{C1} , F_{C2} , F_{C3} .

stead of using a single power supply, three distributed dc power supplies (buck converters) are used so as to ensure that a single fault (on the supply side) does not cause all the loads to lose power. The three power supplies and the three loads are connected through a network, where each transmission line linking two nodes is modeled as a resistor.

We will focus on the problem of detecting hard and soft faults in this system. In particular, we will consider hard faults that cause an open circuit in a transmission line between two nodes. This also covers the case of short-circuits if the transmission elements are fused or they have some sort of relay protection. Soft faults considered include degradation of buck converter capacitors. We assume that the currents i_{L1} , i_{L2} , i_{L3} through the buck converter inductors are measured as well as the voltages v_{load1} , v_{load2} , v_{load3} at the load buses. We assume the converters always work in a continuous conduction mode and therefore, there are eight possible nominal modes. For the parameter values given in Table II, the resulting state-space description matrices are shown in (43) at the bottom of the page, where $p_i \in \{0, 1\}$, with

$i = 1, 2, 3$, and $p = \text{dec}(p_1 p_2 p_3)$, where $\text{dec}(\cdot)$ is the decimal representation of the binary number within the brackets.

1) *Hard Faults in Transmission Lines:* Consider a hard fault occurrence causing the transmission line linking buses 1 and 4 to open, which will result in eight new modes $p = 9 \dots 16$. For clarity of presentation, we just provide the elements of the matrices in (43) that will get modified as a result of this fault. $A_9(4, 4) = \dots = A_{16}(4, 4) = -3.35 \cdot 10^4$; $A_9(4, 5) = \dots = A_{16}(4, 5) = 0$; $A_9(5, 5) = \dots = A_{16}(5, 5) = -3.49 \cdot 10^4$; $A_9(5, 4) = \dots = A_{16}(5, 4) = 0$; $C_9(4, 4) = \dots = C_{16}(4, 4) = 0$; $C_9(4, 5) = \dots = C_{16}(4, 5) = 0.98$.

In the simulation environment, this fault was injected at $t = 2 \cdot 10^{-3}$. The output of the FDI system is displayed in Fig. 9. As it can be seen in Fig. 9(a), at the time of fault occurrence, $t = 2 \cdot 10^{-3}$, the flag F_{14} , which indicates a hard fault in transmission line R_{14} changes from zero to one, whereas the flags for the remaining transmission elements remain at zero, as expected, i.e., there is no false alarm. Fig. 9(b) shows the fault flags for soft faults in the buck converter capacitors, and as expected, they

$$\begin{aligned}
 A_p &= 10^4 \cdot \begin{bmatrix} -0.83 & 0 & 0 & -8.33 & 0 & 0 \\ 0 & -0.83 & 0 & 0 & -8.33 & 0 \\ 0 & 0 & -0.83 & 0 & 0 & -8.33 \\ 0.07 & 0 & 0 & -6.72 & 3.30 & 3.31 \\ 0 & 0.06 & 0 & 3.30 & -6.72 & 3.30 \\ 0 & 0 & 0.07 & 3.31 & 3.31 & -6.71 \end{bmatrix} \\
 E_p &= 10^4 \cdot \begin{bmatrix} 8.33p_1 & 0 & 0 \\ 0 & 8.33p_2 & 0 \\ 0 & 0 & 8.33p_3 \\ 0 & 0 & 0 \\ 0 & 0 & 0 \\ 0 & 0 & 0 \end{bmatrix}, \quad C_p = \begin{bmatrix} 1 & 0 & 0 & 0 & 0 & 0 \\ 0 & 1 & 0 & 0 & 0 & 0 \\ 0 & 0 & 1 & 0 & 0 & 0 \\ 0 & 0 & 0 & 0.495 & 0.495 & 0 \\ 0 & 0 & 0 & 0.497 & 0 & 0.497 \\ 0 & 0 & 0 & 0 & 0.496 & 0.496 \end{bmatrix} \quad (43)
 \end{aligned}$$

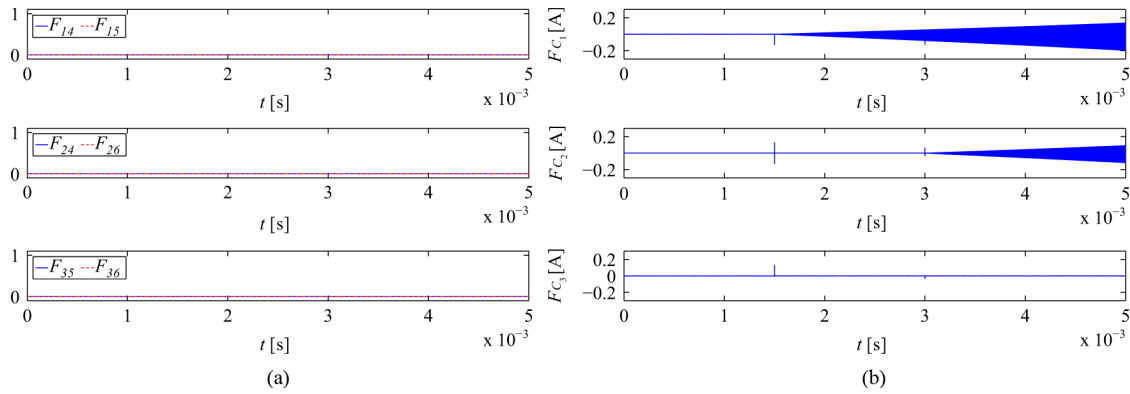

Fig. 10. Time evolution of dc network hard fault flags in transmission lines and soft fault flags in buck converter capacitors for a soft fault in capacitor C_1 starting at $t = 1.5 \cdot 10^{-3}$ and a soft fault in capacitor C_2 starting at $t = 3 \cdot 10^{-3}$. (a) Transmission line fault flags F_{14} , F_{15} , F_{24} , F_{26} , F_{35} , F_{36} . (b) Buck converter capacitor fault flags F_{C_1} , F_{C_2} , F_{C_3} .

remain at zero even after the hard fault occurrence, so there is no false alarm in this case either.

2) *Soft Faults in Buck Converter Capacitors:* In the simulation environment, these faults will be modeled in a similar fashion as in (41) for the boost converter numerical example. To illustrate the ability of the FDI system to detect and isolate two faults, we assume capacitor C_1 starts degrading at $t = 1.5 \cdot 10^{-3}$ and capacitor C_2 starts degrading at $t = 3 \cdot 10^{-3}$. The degradation is exponential as in (41), with a rate of 100 s^{-1} . The FDI system captured both fault occurrences as it can be seen in Fig. 10(b), where the fault flag F_{C_1} corresponding to capacitor C_1 remains at zero until $t = 1.5 \cdot 10^{-3}$ and then starts increasing. The other two fault flags remain at zero until $t = 2 \cdot 10^{-3}$, when F_{C_2} starts increasing, which means capacitor C_2 starts gracefully degrading. Flag F_{C_3} remains at zero at all times, which indicates capacitor C_3 does not degrade in the simulation period considered. It is important to note that the flags for hard faults displayed in Fig. 10(a) remain at zero, indicating no hard faults occurrences.

VI. CONCLUDING REMARKS

It is natural to study the problem of fault detection and isolation for nonlinear switched systems as has been done in [31] for actuator faults. The framework proposed in this paper can be extended to nonlinear systems in conceptually similar manner using the results on invertibility of nonlinear switched systems that appear in [25]. In this regard, preliminary work based on the utilization of the results in [25] to FDI in nonlinear systems is illustrated in [32], with specific application to detecting faults in transmission lines of electric power systems.

Several other issues need to be investigated to ensure the success of the inversion-based FDI approach. As the method relies on differentiation of the outputs, robustness against output measurement noise is imperative. Also, the need for accurate fault impact models could potentially hinder the effectiveness of the method. The inversion-based FDI method is naturally suited for a distributed implementation, which can be accomplished by appropriately breaking the system into smaller interconnected systems. Unlike observer-based methods, where a bank of filters is required (each sensitive to a particular fault), with the inversion-based method, it is unnecessary to have each

faulty system model running concurrently. To illustrate, using the system of Fig. 8, the system could be broken into three interconnected subsystems, each roughly composed of a source, a load and the lines linking these components. Each subsystem will have additional inputs (possibly unknown) resulting from the interconnection with other subsystems. In this scenario, it is possible to undertake FDI locally using the inversion approach. This would also allow the recovery of those possibly unknown inputs introduced when partitioning the system. Additionally, if the individual subsystems are invertible, these unknown inputs can also be uniquely recovered. This would be of interest if such unknown inputs cannot be measured for reconfiguration strategies in the system operation. Also, the observer-based method usually assumes that the switching signal is known whereas our proposed framework does not make any such assumption. These aspects lead to some interesting applications, some of which have been highlighted in this paper.

REFERENCES

- [1] A. Avizienis, "Toward systematic design of fault-tolerant systems," *IEEE Computer*, vol. 30, no. 4, pp. 51–58, Apr. 1997.
- [2] R. Barlow and F. Proschan, *Mathematical Theory of Reliability*. New York, NY: Wiley, 1965.
- [3] A. Willsky, "A survey of design methods for failure detection systems," *Automatica*, vol. 12, no. 6, pp. 601–611, Nov. 1976.
- [4] R. Isermann, "Process fault detection based on modeling and estimation methods—a survey," *Automatica*, vol. 20, no. 4, pp. 387–404, 1984.
- [5] R. Patton, P. Frank, and R. Clarke, Eds., *Fault Diagnosis in Dynamic Systems: Theory and Application*. Upper Saddle River, NJ: Prentice-Hall, 1989.
- [6] R. Isermann, *Fault-Diagnosis Systems: An Introduction From Fault Detection to Fault Tolerance*. Heidelberg, Germany: Springer-Verlag, 2006.
- [7] F. Chowdhury, J. Christensen, and J. Aravena, "Kalman filter with hypothesis testing," *IEEE Trans. Power Del.*, vol. 6, pp. 1025–1030, Jul. 1991.
- [8] E. Scholtz, "Observer-based monitors and distributed wave controllers for electromechanical disturbances in power systems," Ph.D. dissertation, Dept. Elect. Eng. Comput. Sci., Massachusetts Inst. Technol., Cambridge, MA, 2004.
- [9] H. Rodriguez-Cortes, A. Stankovic, and C. Hadjicostis, "Model-based fault detection in power systems," in *Proc. IEEE Int. Symp. Ind. Electron.*, Jul. 2006, vol. 3, pp. 1922–1927.
- [10] R. Peugeot, S. Courtine, and J. P. Rognon, "Fault detection and isolation on a PWM inverter by knowledge-based model," *IEEE Trans. Ind. Appl.*, vol. 34, no. 6, pp. 1318–1326, Nov./Dec. 1998.
- [11] R. de Araujo Ribeiro, C. Jacobina, E. da Silva, and A. Lima, "Fault detection of open-switch damage in voltage-fed PWM motor drive systems," *IEEE Trans. Power Electron.*, vol. 18, no. 2, pp. 587–593, Mar. 2003.

- [12] S. Ebron, D. Lubkeman, and M. White, "A neural network approach to the detection of incipient faults on power distribution feeders," *IEEE Trans. Power Del.*, vol. 5, no. 2, pp. 905–914, Apr. 1990.
- [13] M. Kezunovic, "Accurate fault location in transmission networks using modeling, simulation and limited field record data," Power Systems Engineering Research Center, 2002.
- [14] S. Khomfoi and L. Tolbert, "Fault diagnostic system for a multilevel inverter using a neural network," *IEEE Trans. Power Electron.*, vol. 22, no. 3, pp. 1062–1069, May 2007.
- [15] S. Mohagheghi, R. Harley, T. Habetler, and D. Divan, "Condition monitoring of power electronic circuits using artificial neural networks," *IEEE Trans. Power Electron.*, vol. 24, no. 10, pp. 2363–2367, Oct. 2009.
- [16] F. Chowdhury and J. Aravena, "A modular methodology for fast fault detection and classification in power systems," *IEEE Trans. Control Syst. Technol.*, vol. 6, no. 5, pp. 623–634, Sep. 1998.
- [17] D. Diallo, M. Benbouzid, D. Hamad, and X. Pierre, "Fault detection and diagnosis in an induction machine drive: A pattern recognition approach based on concordia stator mean current vector," *IEEE Trans. Energy Conv.*, vol. 20, no. 3, pp. 512–519, Sep. 2005.
- [18] *Issues of Fault Diagnosis for Dynamic Systems*, R. Patton, P. Frank, and R. Clark, Eds. Heidelberg, Germany: Springer Verlag, 2000.
- [19] R. Beard, "Failure accommodation in linear systems through self-reorganization," Man Vehicle Lab., Massachusetts Inst. Technol., Cambridge, MA, Tech. Rep. MVT-71-1, 1971.
- [20] H. Jones, "Failure detection in linear systems," Ph.D. dissertation, Dept. Aeronaut. Astronaut., Massachusetts Inst. Technol., Cambridge, MA, 1973.
- [21] , D. Luenberger, Ed., *Introduction to Dynamic Systems*. New York: Wiley, 1979.
- [22] A. Willsky and H. Jones, "A generalized likelihood ratio approach to the detection and estimation of jumps in linear systems," *IEEE Trans. Autom. Control*, vol. 21, no. 1, pp. 108–112, Feb. 1976.
- [23] *Robust Model-Based Fault Diagnosis for Dynamic Systems*, J. Chen and R. Patton, Eds. Boston, MA: Kluwer Academic, 1999.
- [24] L. Vu and D. Liberzon, "Invertibility of switched linear systems," *Automatica*, vol. 44, no. 4, pp. 949–958, 2008.
- [25] A. Tanwani and D. Liberzon, "Invertibility of nonlinear switched systems," in *Proc. IEEE 47th Conf. Decision Control*, 2008, pp. 286–291.
- [26] F. Szigeti, C. Vera, J. Bokor, and A. Edelmayer, "Inversion based fault detection and isolation," in *Proc. IEEE Conf. Decision Control*, Orlando, FL, Dec. 2001.
- [27] D. Liberzon, *Switching in Systems and Control*. Boston, MA: Birkhäuser, 2003.
- [28] L. M. Silverman, "Inversion of multivariable linear systems," *IEEE Trans. Autom. Control*, vol. 14, no. 3, pp. 270–276, Jun. 1969.
- [29] L. M. Silverman and H. J. Payne, "Input-output structure of linear systems with application to decoupling problem," *SIAM J. Control Opt.*, vol. 9, no. 2, pp. 199–233, 1971.
- [30] "Plexim GmbH. PLECS-piece-wise linear electrical circuit simulation, Version 2.2," 2009. [Online]. Available: <http://www.plexim.com/>
- [31] P. Mhaskar, C. McFall, A. Gani, P. D. Christofides, and J. F. Davis, "Isolation and handling of actuator faults in nonlinear systems," *Automatica*, vol. 44, pp. 53–62, 2008.
- [32] A. Tanwani, "Invertibility of switched nonlinear systems," M.S. thesis, Dept. Elect. Comput. Eng., Univ. Illinois at Urbana-Champaign, Urbana-Champaign, 2008.



Aneel Tanwani (S'08) received the undergraduate degree in mechatronics engineering from National University of Sciences and Technology, Pakistan, in 2005, the DEA in automatique-productique from Institut National Polytechnique de Grenoble, Grenoble, France, and the M.S. degree in electrical engineering from University of Illinois, Urbana-Champaign, where he is currently pursuing the Ph.D. degree from the Department of Electrical and Computer Engineering.

He worked with the Laboratoire Automatique de Grenoble. His research interests include switched and hybrid dynamical systems, nonlinear control, systems theory and related applications.



Alejandro D. Domínguez-García (S'02–M'07) received the degree of Electrical Engineer from the University of Oviedo, Oviedo, Spain, in 2001 and the Ph.D. degree in electrical engineering and computer science from the Massachusetts Institute of Technology, Cambridge, in 2007.

He is an Assistant Professor with the Electrical and Computer Engineering Department, University of Illinois, Urbana-Champaign, where he is affiliated with the power and energy systems area. His research interests include the areas of system reliability theory and control, and their applications to electric power systems, power electronics, and embedded electronic systems for safety-critical/fault-tolerant aircraft, aerospace, and automotive applications. After finishing his Ph.D., he spent some time as a postdoctoral research associate with the Laboratory for Electromagnetic and Electronic Systems, Massachusetts Institute of Technology.

Dr. Domínguez-García was a recipient of the NSF CAREER Award in 2010.



Daniel Liberzon (M'98–SM'04) received the undergraduate studies degree from Moscow State University, Moscow, Russia, in 1993 and the Ph.D. degree in mathematics from Brandeis University, Waltham, MA, in 1998.

Following a postdoctoral position at Yale University, he joined the University of Illinois at Urbana-Champaign, where he is now an Associate Professor with the Electrical and Computer Engineering Department and a Research Associate Professor with the Coordinated Science Laboratory.

His research interests include switched and hybrid systems, nonlinear control theory, control with limited information, and stochastic systems. He is the author of the book *Switching in Systems and Control* (Birkhauser, 2003), and the author or coauthor of over 30 journal papers.

Dr. Liberzon was a recipient of the IFAC Young Author Prize and the NSF CAREER Award, both in 2002, the Donald P. Eckman Award from the American Automatic Control Council in 2007, and the Xerox Award for Faculty Research from the UIUC College of Engineering also in 2007.