

Finite Element Analysis for Whole Machine of Link-Type Ladle Turret

Lingling Li^{1,a}, Guangpu Xu^{2,b}, Bingbing Cui^{3,c}

¹ School of Mechanical Engineering and Automation, University of Science and Technology Liaoning Liaoning, Anshan, Liaoning Province, 114051, China

² School of Mechanical Engineering and Automation, University of Science and Technology Liaoning Liaoning, Anshan, Liaoning Province, 114051, China

³ School of Mechanical Engineering and Automation, University of Science and Technology Liaoning Liaoning, Anshan, Liaoning Province, 114051, China

^alilingling1965@126.com, ^bxuguangpu001@163.com, ^cxueer188@163.com

Keywords: link-type; ladle turret; whole machine; finite element

Abstract: The mechanism withstands 220t high temperature molten steel. In case of damage, molten steel pours. There will be major security incidents. Therefore, it is necessary to calculate carrying capacity of the mechanism. However, the part of components of the mechanism is made up of a crisscross of steel plate. This is used to withstand the bending and stretching. If we rely on traditional mechanical analysis, a large number of simplifying must be adopted, and accuracy of the calculation can be reduced. Therefore, this paper uses the COSMOSWorks Plug-in of SolidWorks software to carry out finite element calculation of whole machine for the mechanism. It avoids these shortcomings mentioned above. And this makes bearing capacity calculation to be more close to the actual circumstances. And the results show that: (1) the maximum stress of parts in the mechanism is only 52.8Mpa and much less than permissible stresses of its materials. As a result, the mechanism has sufficient bearing capacity. (2) The maximum displacement of whole machine is 2.637 mm. And the displacement will cause 2" dip angle when lifting molten steel and it is less than its allowable stiffness. Therefore, the deformation is to meet requirements for the mechanism. In conclusion, the finite element analysis of the whole machine avoids complex force analysis and simplification of structure. The calculation has high accuracy. It is one of effective methods in the design of intensity and stiffness of complex structures.

Introduction

Ladle turret is important mechanical equipment of connecting steelmaking and continuous casting production. Its role is to send the ladle filled with molten steel and delivered by steelmaking span to casting position of continuous casting span. And then the empty ladle is sent back steelmaking span after casting molten steel through rotation of the turret.

with the continuous progress of steelmaking and continuous casting production, the ladle turret has gone through a series of advancements, from a single rotation device to multifunctional ladle turret such as having a lifting device, weighing device and capping device, etc.[1~3]. This paper bases its study on the lifting device of current popular link-type ladle turret, carries out finite element calculation of whole machine. The aim is to provide corresponding theoretical basis for safety and stability of the mechanism.

Finite element analysis

In order to investigate safety and stability of the mechanism, COSMOSWorks software is used to carry out strength and stiffness analysis of whole machine for lifting mechanism.

The COSMOSWorks software is a Plug-in of SolidWorks software. Compared with ANSYS software and MARC software, it is easy for modelling and it hardly needs simplifying, the model is not distorted. It is particularly useful for Finite Element Analysis of fine structure of sharp corner, etc. and the structure of complex assembly.

Part design modeling and virtual assembly. Owing to lifting mechanism of ladle turret is composed of two sets of identical linkage mechanisms, so we take a set of mechanisms to analyze here.

To facilitate division of finite element mesh of whole machine, the fine structure of having little effect on analysis results has been simplified. The features that are tension, array, remove, scan and mirror are used when Parts are designed. And main parts of lifting mechanism of ladle turret are created. These parts are three-dimensional. They include top link, down link, bracket arm and machine rack etc.

We use this assembly in the form which is from bottom to top for virtual assembly of the lifting mechanism of the ladle turret. And assembly constraint relationships which is coincident, concentric, vertical, parallel etc. are joined for parts. All parts are assembled together. Three-dimensional model of the assembly of whole machine is shown in Figure 1.

Geometry model processing. Practice and theoretical analysis show that the lifting mechanism can bear maximum load when it rises to a highest position. So we use the highest position as Position of intensity analysis. As axial deformation of cylinder is smaller and difficult to determine. Therefore, it is simplified as a rigid body in the geometric model. Geometric model as shown in Figure 1

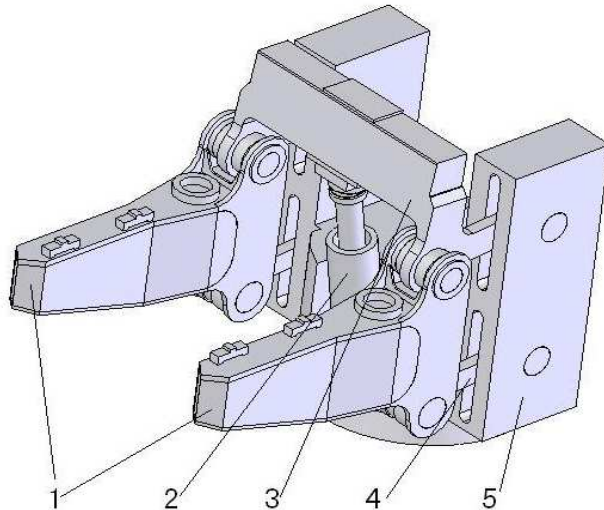

1 bracket arm ;2 cylinder ;3 top link; 4 down link;5 machine rack

Fig.1 Assembly of Steel package rotating station

Boundary conditions. The fixed constraint of lower surface of rack base is displacement constraints of the model. Load of the structure suffered is actual weight of the ladle. It is 220t. And it is allocated to four Support surface of weighing mechanism of right and left bracket arm top. And then the fixed constraint is applied at the bottom of the rack (Figure 2). Considering the impact factor when starting and stopping, the dynamic load coefficient should be multiplied. Based on relevant documentations, the dynamic load coefficient is 1.6[4-6]. And the load of average sharing on four Support surface is 88t.

Material parameters. Q345-C sheet material is used to manufacture the lifting mechanism of the ladle turret. Property parameter of the material is shown in Table 1.

Table 1 Property parameter of material

material	density [kg·m ⁻³]	elastic modulus [Mpa]	Poisson ratio
Q345-C	7.8×10 ³	2.12×10 ⁵	0.31

Finite element model. The 3D element of hexahedron is used while the lifting mechanism of the ladle turret is discretized. After repeatedly modified the grid, it is divided into 50329 elements and 46769 nodes, the finite element model of whole structure is finally obtained. It is shown in Figure 2.

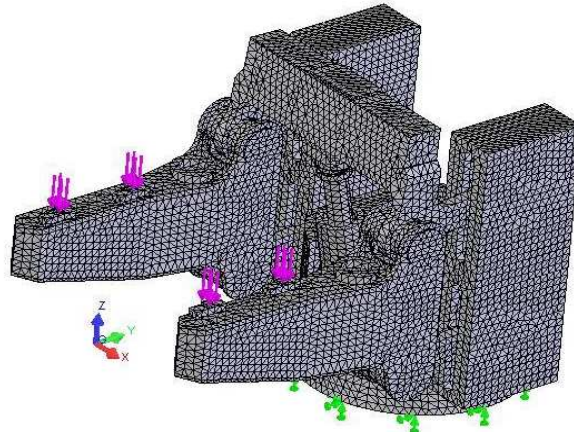

Fig.2 Finite element model

Result analysis. Through computing, overall displacement cloud chart is obtained as shown in Figure 3. From fig.3, the maximum displacement of whole machine is 2.637 mm and in front of the bracket arm. Length of the bracket arm is 4920mm. And it will produce 2" dip angle when lifting molten steel. This angle is very small. It will have a negligible effect on the stability of the molten steel. Therefore, the stiffness of the mechanism is satisfied. And the maximum displacement is consistent with actual measurement of displacement 3mm. This indicates that the Finite Element Calculation is correct and confident.

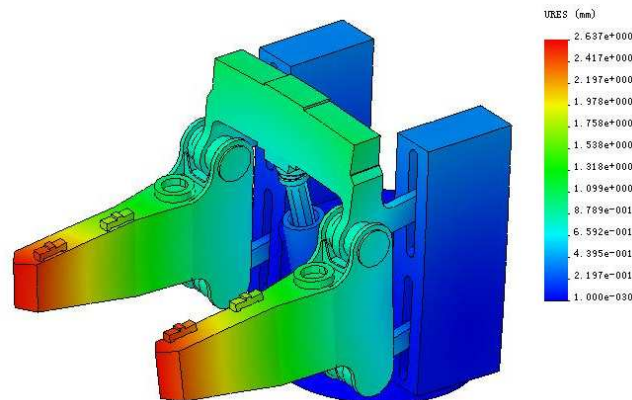

Fig.3 Deformation of complete appliance(mm)

In order to fully understand stress distribution and size of each component, explosive drawing of parts stress is generated as shown in Figure 4. From fig.4, The maximum stress of the top link occurred at the foot of being linked with machine rack, and the maximum stress is about 40MPa. The maximum stress of the down link occurred below the foot of being linked with machine rack, and the maximum stress is about 52.8Mpa. The maximum stress of the bracket arm occurred at its upper and lower strengthening rib. It is approximately between 30MPa ~ 39Mpa. The maximum stress of all parts is much less than yield limit and intensity limit of its material. So, the mechanism have sufficient bearing capacity.

If classical mechanics of materials is used to calculate bending stress of the bracket arm, it can make the calculation become more difficult because the bracket arm is cantilever construction beam of variable cross section and the variable cross section and strengthening rib can influence the calculation.

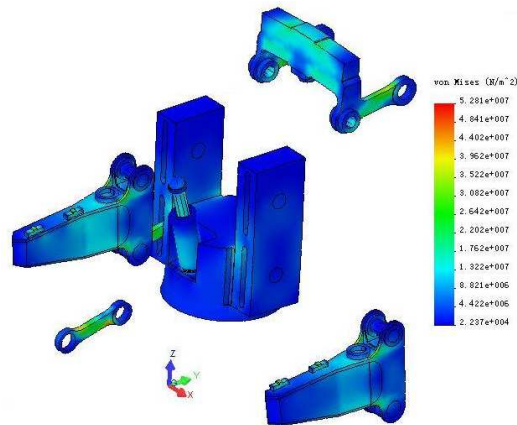

Fig.4 Stress of parts(Pa)

Similarly, If classical mechanics of materials is used to calculate bending stress of the top link, there is great difficulty in calculating section moments of inertia because the top link is structural member of crisscross of ribs. Meanwhile, because of the complexity of its force, there exist tension and bending. This added difficulty for us to calculate strength.

In conclusion, comparative to the calculation of the classical mechanics of materials, the finite element analysis of the strength for the whole machine has features of simple calculation and high accuracy. And it can effectively evaluate intensity and stiffness of the parts. It is one of the efficacious methods in the dealing with bearing capacity of the complex structure

Conclusion

This thesis takes Solidworks software as design platform, the three-dimensional modeling and virtual assembly are carried out on the lifting mechanism of the link-type ladle turret. And the finite element analysis for the whole machine is made. Find through the finite element analysis of this thesis: the mechanism has enough intensity and stiffness.

The finite element analysis of the whole machine avoids complex force analysis and some unnecessary assumptions when determining the load. And the calculation has high accuracy and the operation is simple and not easy to make mistakes. It is one of the effective methods in the design of strength and stiffness in engineering.

References

- [1] Zhencai Luo, Steel-making Machinery [M], Metallurgical Industry Press, Beijing, 2008, pp.161-164
- [2] Jinming Tao, Ladle and ladle turret, Metallurgical Equipment, 1992(5), 42-47
- [3] Ya li He, A discussion on design of ladle turret, Iron and steel technology, 2000(4), 27-29
- [4] Xiaochun Zhang, Zhenwen Yuan, Ladle turret three-dimensional modeling and FEA on Pro/E, Heavy Machinery, 2009(2), 52 -54
- [5] Yiwu Xie, Theoretical calculation analysis for the impact coefficient of receiving pot on ladle turret [J], Metallurgical Equipment, 1998, 107(2):24-25.
- [6] Huijian Li, Wenfeng Tan, Qingyuan Tang, Study on dynamic load characteristics of linkage ladle turret. Iron and Steel, 1996,31(10):55~57.