



# Fermi National Accelerator Laboratory

FERMILAB-Conf-99/212

## **Working with Arrays of Inexpensive EIDE Disk Drives (Including an Appendix with a December 1999 Update)**

David Sanders, Chris Riley, Lucien Cremaldi and Don Summers

*University of Mississippi - Oxford*

Don Petravick

*Fermi National Accelerator Laboratory  
P.O. Box 500, Batavia, Illinois 60510*

January 2000

Published Proceedings of *Computing in High Energy Physics Conference (CHEP '98)*,  
Chicago, Illinois, August 31-September 4, 1998

## **Disclaimer**

*This report was prepared as an account of work sponsored by an agency of the United States Government. Neither the United States Government nor any agency thereof, nor any of their employees, makes any warranty, expressed or implied, or assumes any legal liability or responsibility for the accuracy, completeness, or usefulness of any information, apparatus, product, or process disclosed, or represents that its use would not infringe privately owned rights. Reference herein to any specific commercial product, process, or service by trade name, trademark, manufacturer, or otherwise, does not necessarily constitute or imply its endorsement, recommendation, or favoring by the United States Government or any agency thereof. The views and opinions of authors expressed herein do not necessarily state or reflect those of the United States Government or any agency thereof.*

## **Distribution**

*Approved for public release; further dissemination unlimited.*

## **Copyright Notification**

*This manuscript has been authored by Universities Research Association, Inc. under contract No. DE-AC02-76CH03000 with the U.S. Department of Energy. The United States Government and the publisher, by accepting the article for publication, acknowledges that the United States Government retains a nonexclusive, paid-up, irrevocable, worldwide license to publish or reproduce the published form of this manuscript, or allow others to do so, for United States Government Purposes.*

# Working with Arrays of Inexpensive EIDE Disk Drives (including an Appendix with a December 1999 Update)

David Sanders, Chris Riley, Lucien Cremaldi, and Don Summers  
University of Mississippi–Oxford

Don Petravick  
Fermilab

## Abstract:

In today's marketplace, the cost per Terabyte of disks with EIDE interfaces is about a third that of disks with SCSI. Hence, three times as many particle physics events could be put online with EIDE. The modern EIDE interface includes many of the performance features that appeared earlier in SCSI. EIDE bus speeds approach 33 Megabytes/s and need only be shared between two disks rather than seven disks. The internal I/O rate of very fast (and expensive) SCSI disks is only 50 per cent greater than EIDE disks. Hence, two EIDE disks whose combined cost is much less than one very fast SCSI disk can actually give more data throughput due to the advantage of multiple spindles and head actuators. We explore the use of 12 and 16 Gigabyte EIDE disks with motherboard and PCI bus card interfaces on a number of operating systems and CPUs. These include Red Hat Linux and Windows 95/98 on a Pentium, MacOS and Apple's Rhapsody/NeXT/UNIX on a PowerPC, and Sun Solaris on a UltraSparc 10 workstation.

Computing in High Energy Physics Conference (CHEP '98)  
August 31 – September 4, 1998  
Hotel Inter-Continental  
Chicago, Illinois, USA

Contact: [sanders@relativity.phy.olemiss.edu](mailto:sanders@relativity.phy.olemiss.edu)

This work was supported by the U.S. Department of Energy under grant DE-FG02-91ER40622 and contract DE-AC02-76CH03000.

## Introduction

In today's marketplace, the cost per Terabyte of disks with EIDE (Enhanced Integrated Drive Electronics) interfaces is about a third that of disks with SCSI (Small Computer System Interface). Hence, three times as many particle physics events could be put online with EIDE. The modern EIDE interface includes many of the performance features that appeared earlier in SCSI. EIDE bus speeds approach 33 Megabytes/s and need only be shared between two EIDE disks rather than seven SCSI disks. The internal I/O rate of very fast (and expensive) SCSI disks is only 50 percent greater than EIDE disks. Direct Memory Access (DMA), scatter/gather data transfers without intervention of the Central Processor Unit (CPU), elevator seeks, and command queuing are now available for EIDE, as well as support for disks larger than 8.4 Gigabytes. PCI (Peripheral Control Interface) cards allow the addition of even more EIDE interfaces, in addition to those already on the motherboard.

## Motivation

There are a number of High Energy Physics Experiments that have produced Terabytes of data [1]. A few examples as of 12/95 are:

<b>Experiment</b>	<b>Data set (Terabytes)</b>
FNAL-E791	50
FNAL-D0	40
FNAL-CDF	10
HERA-ZEUS	5
CESR-CLEO	5
LEP-Delphi	~5
LEP-L3	3.4
HERA-H1	2.5
LEP-Aleph	1.7
LEP-OPAL	1.5

The efficiency of data analysis is greatly enhanced by using disk based files of filtered Data Summary Tapes (DSTs) rather than continually loading files from tapes. However, the high cost of disks have hindered more widespread use. Low cost EIDE disks are improving this situation.

## Big Disks

<b>EIDE Disk Model</b>	Bigfoot	Deskstar	Deskstar	Diamond
Manufacturer	Quantum	IBM	IBM	Maxtor
Capacity (Gigabytes)	12	16.8	14.4	17.2
Max. Internal I/O (Mbits/s)	142	162	174	
Avg. Seek Time (ms)	12.0	9.5	9.5	9.0
RPM	4000	5400	7200	5400
Unit Street Cost	\$241	\$407	\$407	\$410
Cost \$/Terabyte	\$20000	\$24000	\$28000	\$24000

<b>SCSI Disk Model</b>	Cheetah	Ultrastar
Manufacturer	Seagate	IBM
Capacity (Gigabytes)	18.2	18
Max. Internal I/O (Mbits/s)	231	180
Avg. Seek Time (ms)	5.7	6.5
RPM	10000	7200
Unit Street Cost	\$1242	\$1000
Cost \$/Terabyte	\$68000	\$55000

## Tests Performed

For this paper we tested two of the large capacity EIDE disks with six different operating systems and a PCI EIDE disk controller card. The six operating systems are Mac OS 8.1, Apple Rhapsody DR2, Sun Solaris 2.6, Windows 95b, Windows 98, and RedHat LINUX 5.1 (kernel 2.0.34). The two disk drives and the disk controller card are described below:

- Quantum Bigfoot<sup>TM</sup> TX [2] 12 GB, 4000 RPM, 142 Mbits/sec Maximum internal data rate, 12 ms average seek time.
- The IBM Deskstar<sup>TM</sup> 16GP [3]. 16.8 GB, 5400 RPM, 162 Mbits/sec Maximum internal data rate, 9.5 ms average seek time.
- Promise Technologies Ultra 33<sup>TM</sup> PCI EIDE controller card [4]. Supports 4 drives, Ultra ATA/EIDE/Fast ATA-2. Cost: \$50.

Both the Quantum Bigfoot<sup>TM</sup> TX 12 GB and the IBM Deskstar<sup>TM</sup> 16GP 16 GB disks were successfully tested with the following systems:

System	Notes
Mac OS 8.1 on a Macintosh G3 [5] rev. 2 motherboard	With HFS+ and both Master/Slave.
Windows 95b on a Dell Dimension XPS 350 computer [6] with PhoenixBIOS	Ok, depending on the BIOS <sup>1</sup> . Use FAT 32.
Windows 98 on a Dell Dimension XPS 350 computer [6] with PhoenixBIOS	Ok, depending on the BIOS <sup>1</sup> . Use FAT 32.
RedHat LINUX 5.1 (kernel 2.0.34) on a Dell Dimension XPS 350 computer [6] with PhoenixBIOS	Ok, depending on the BIOS <sup>1</sup> .
Promise Technologies Ultra 33 on a Dell Dimension XPS 350 computer [6] with PhoenixBIOS	Ok with Windows 95b and Windows 98. However, a patch <sup>2</sup> was needed for Red Hat LINUX.

## Ten Terabyte EIDE Disk Architecture

The recipe for a simple 10 Terabyte EIDE Disk Architecture is as follows:

- Attach eight 16GB EIDE disks to each of 75 CPUs with the help of Promise PCI controller cards.
- Since EIDE cables have a maximum length of 18", it is easier to run extra DC power cables into a computer tower than to run EIDE cables out.
- Load data on these disk arrays.
- Plan to usually run analysis jobs on the same machine as the data.
- Use fast Ethernet switches to allow for remote jobs at a modest level.

## Future

Future plans may include testing the drives with Apple Rhapsody, Sun Solaris, and newer releases of Red Hat LINUX. (The 8 GB limit seen so far on Rhapsody DR2 and Solaris 2.6 may be fixed in later releases.) Also new technologies that are worth investigating include both "Lazy RAID" and Firewire<sup>TM</sup>.

<sup>1</sup>See "Getting beyond the ATA 8.4 GB limit"

<http://www.storage.ibm.com/hardsoft/diskdrdl/library/8.4gb.htm>  
<http://www.storage.ibm.com/techsup/hddtech/welcome.htm>  
<http://www.storage.ibm.com/hardsoft/diskdrdl/prod/deskstar.htm>  
<http://www.storage.ibm.com/hardsoft/diskdrdl/prod/ultrastar.htm>  
and "8.4 GB Barrier"  
<http://www.quantum.com/src/whitepapers/8.4barrier.html>  
<http://www.quantum.com/products/hdd/bigfoot.tx/>  
and "IDE Hard Drive Capacity Barriers"  
<http://www.maxtor.com/technology/whitepapers/capbar0.html>

<sup>2</sup>Patch available from <http://pobox.com/~brion/linux/promise34.gz>, but support is included in kernel 2.0.35

# Lazy RAID

Lazy RAID (Redundant Array of Inexpensive Disks) is an idea for using disk arrays that offers protection for disks in the event of catastrophic failure of one disk in the array. This system uses a number of data disks (say 7) plus one parity disk. Therefore, if one disk dies the parity disk would allow the recovery of data from the dead disk. One could use the RAW DEVICE interface to calculate parity with the CPU. If a disk fails then the operator would swap out the dead EIDE drive and reconstitute the dead disk drive onto the replacement drive using the parity disk and the remaining data disks. This system is well suited for use as scratch disks where a filtered DST is placed on disk once and read and analyzed many times. Using this scheme the one parity disk is updated only when a file is written to (or erased from) a disk.

# Firewire

Firewire IEEE 1394 Specifications [7]:

- Up to 25 or 50 Megabyte/s.
- Up to 63 devices per interface.
- Uses two twisted pair data lines.
- “Fairness” bus arbitration.
- Supported by MacOS and Windows 98.

A printed circuit board and DSP driver software would have to be developed using the TI chip set . Shown below is a Firewire to EIDE Disk Block Diagram that might allow one Terabyte Per PCI Slot:

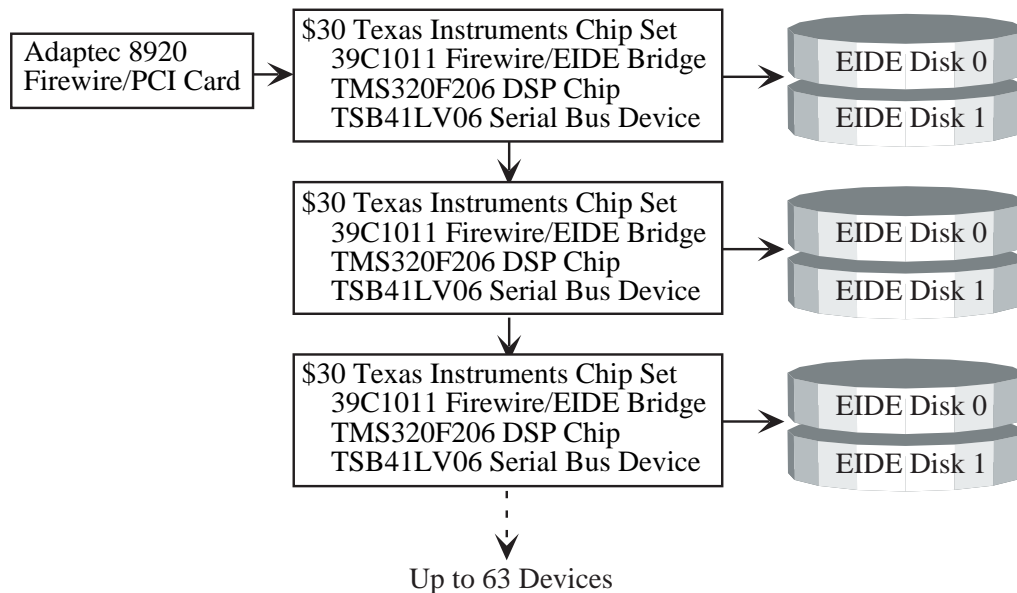

## Conclusion

EIDE disk arrays are an inexpensive way to add large amounts of disk space to both single Workstations (and PCs) and multiprocessor computing farms. They provide an additional layer to the data storage “cake”.

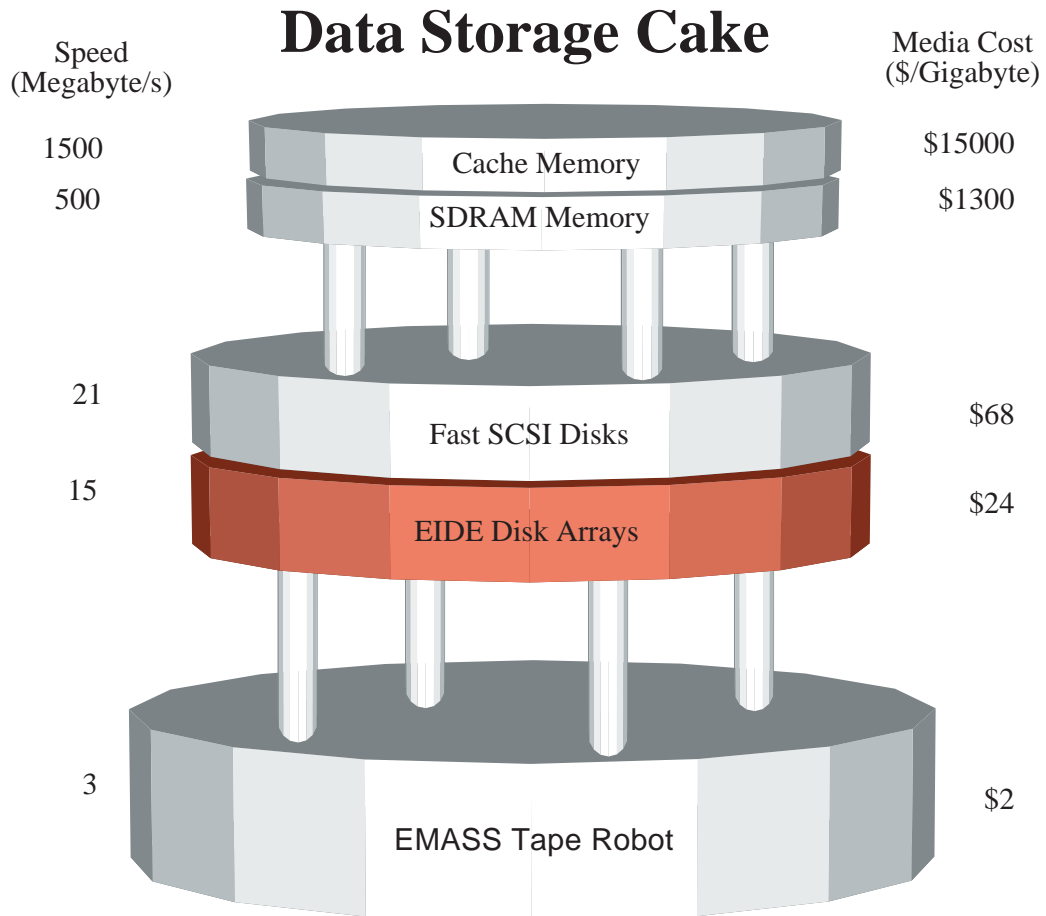

[1] S. Bracker, K. Gounder, K. Hendrix, and D. Summers, *A Simple Multiprocessor Management System for Event-Parallel Computing*, IEEE NS-43 (1996) 2457.

[2] [http://www.quantum.com/products/hdd/bigfoot\\_tx/](http://www.quantum.com/products/hdd/bigfoot_tx/)

[3] <http://www.storage.ibm.com/hardsoft/diskdrdl/desk/1614data.htm>

[4] <http://www.promise.com/html/sales/Ultra33.html>

[5] <http://www.apple.com/powermac/g3/>

[6] <http://www.dell.com/products/dim/xpsr/specs/index.htm>

[7] <http://www.skipstone.com/info.html>

[8] <http://www.ti.com/sc/docs/news/1998/98029.htm>;  
<http://www.ti.com/sc/docs/dsps/details/43/flash.htm>;  
<http://www.ti.com/sc/docs/msp/1394/41lv0x.htm>;  
<http://www.ti.com/sc/docs/storage/products/cont.htm>



## Appendix: EIDE/ATA Disk Drive Update — December 1999

Costs of disk drives with EIDE/ATA interfaces [1] have fallen since the Chicago CHEP '98 conference. Drive capacity and I/O rates have risen. EIDE/ATA disks beyond the old 8 Gigabyte limit now work with more platforms and cards. EIDE disks remain more than twice as cost effective as SCSI disks and now equal the internal I/O speeds of many SCSI disks. We have run RAID 5 on EIDE disks under Linux which both stripes data across disks for speed and provides parity bits for data recovery. Tape backup may no longer be required to recover from one disk failure in a set. Arrays of EIDE disks with Linux PCs serving as disk controllers are attractive and may provide many Terabytes of economical rotating online storage. The cost of a quarter Petabyte EIDE disk farm is approaching the cost of a StorageTek PowderHorn silo [2] with 5000 50 Gigabyte RedWood tapes. Finally, we include more information on IEEE-1394 FireWire which may allow Terabyte arrays of EIDE/ATA disks to be directly connected to one or more computers at up to 50 Megabytes/second per interface.

Table 1.	Disk Capacity	Maximum Internal I/O	Avg. Seek	Unit	Street Cost	Dollars per Terabyte
<b>EIDE/ATA</b>	in Gigabytes	Mbits/s	ms	RPM	[3]	
Maxtor DiamondMax 40 [4]	40.9	295	9.0	5400	\$243	\$6000
IBM Deskstar 37GP [5]	37.5	248	9.0	5400	\$302	\$8100
IBM Deskstar 34GXP [5]	34.2	284	9.0	7200	\$311	\$9100
Seagate Barracuda ATA [6]	28.5	323	8.6	7200	\$211	\$7400
Western Digital Expert [7]	27.2	284	9.0	7200	\$236	\$8700
Western Digital Caviar [8]	30.7	271	9.5	5400	*	*
Quantum Fireball <i>lct10</i> [9]	30.0	297	8.9	5400	*	*
Maxtor DiamondMax Plus [10]	40.9	345	9.0	7200	*	*

Table 2.	Disk Capacity	Maximum Internal I/O	Avg. Seek	Unit	Street Cost	Dollars per Terabyte
<b>SCSI</b>	in Gigabytes	Mbits/s	ms	RPM	[2]	
Seagate Barracuda [11]	50.1	264	7.4	7200	\$806	\$16 100
Quantum Atlas 10K [12]	36.4	315	5.0	10000	\$945	\$26 000
IBM Ultrastar 36XP [13]	36.4	231	7.5	7200	\$756	\$20 800
IBM Ultrastar 72ZX [14]	73.4	473	5.3	10000	*	*
Seagate Cheetah 73 [15]	73.4	427	5.6	10000	*	*

\* Announced, but not yet shipping.

We now have our 12 GB Quantum Bigfoot TX [16] and 16.8 GB IBM Deskstar 16GP [17] EIDE drives running in our Sun Ultra 10 workstation. We put in a newer motherboard (Sun Part No. 375-0009-09, Date Code: 9843 DARWIN M/B) and upgraded the operating system from Solaris 2.6 to Solaris 7. We did not test the two changes individually, but one or both put us over the old 8 Gigabyte limit.

Promise Technology now sells their Ultra66 [18] EIDE to PCI controller card. The Ultra66 provides up to 66 MB/s on each of two channels with two drives per channel. The card costs \$40. We use Promise's previous 33 MB/s EIDE to PCI card daily in our Linux PC server (mail, backup...) with IBM Deskstar disks [19].

ProMAX [20] sells a TurboMAX/ATA 33 Host Adapter for Macintosh PCI buses. It allows adding four EIDE drives to an Apple Macintosh. Disks can be striped in pairs. FirmTek [21] is working on an Apple Macintosh software driver for the Promise Ultra66 EIDE to PCI card.

### **Terabytes of Linux RAID 5 Disks**

RAID [22] stands for Redundant Array of Inexpensive Disks. Many industry offerings meet all of the qualifications except the inexpensive part, severely limiting the size of an array for a given budget. This may change. RAID on EIDE disks under Linux software which both stripes data across disks for speed and provides parity bits for data recovery (RAID 5) is now available [23]. With redundant disk arrays, tape backup is not needed to recover from the failure of one disk in a set. This removes a major obstacle to building large arrays of EIDE disks. A RAID 5 set of eight 41 Gigabyte disks fits in a full tower case of a PC running Linux. This provides over a quarter of a Terabyte per box. The boxes would be connected using 100 Megabit/second Fast Ethernet PCI cards in each box plus Ethernet switches [24, 25]. This looks to be very doable.

We have done a quick test of the Linux RAID 5 software using two 25 Gigabyte IBM Deskstar 25GP [19] EIDE disks. The host was a Pentium II with Red Hat Linux 6.0 [26] and a Promise Technology Ultra 33 EIDE/PCI card. The test ran as expected. Naturally, half the disk space is devoted to parity with only two disks. For a real RAID 5 system, eight or more disks would be a more efficient use of space. The fraction of disk space devoted to parity equals the inverse of the number of disks in a set.

On a mundane note, disk drives typically draw two amps at 12 volts for 15 seconds when starting. Thus eight drives can draw 16 amps at 12 volts. This can tax the ratings of an inexpensive commodity 300 watt PC power supply. Care needs to be taken to choose a supply with a large portion of its wattage devoted to 12 volts. The U.S. EPA Energy Star/Green PC Initiative has led to the development of a Standby command for disks that might allow a staggered startup of a disk array. The command `"/sbin/hdparm -S n"` will spin down disks under Linux. As array size grows, a second commodity 300 watt PC power supply might be required per case.

Table 3: Power consumption of large EIDE disk drives.

<b>EIDE/ATA</b>	Disk Drive Model	GB	Startup		Seek Watts	Read/ Write/ Idle	Standby Watts
			5V Amps	12V Amps		Watts	
	Maxtor DiamondMax 40 [4]	40.9	0.3	2.1	11.0	5.2	1.3
	IBM Deskstar 37GP [5]	37.5	1.0	2.0		4.9	
	IBM Deskstar 34GXP [5]	34.2	1.0	2.0		6.9	
	Seagate Barracuda ATA [6]	28.5	0.7	2.4	9.7	7.0	0.8
	Western Digital Expert [7]	27.2	0.7	2.0	10.1	6.9	0.8
	Western Digital Caviar [8]	30.7	0.6	1.8	10.0	6.2	1.3
	Quantum Fireball <i>lct10</i> [9]	30.0	0.7	1.7		5.0	
	Maxtor DiamondMax Plus [10]	40.9	0.6	2.5	12.9	6.7	1.4

### Comparison of Quarter Petabyte Disk and Tape Storage Systems

In Table 4, we compare a quarter Petabyte EIDE disk farm to an automated StorageTek PowderHorn tape silo [2] with eight RedWood tape drives and 5000 50 Gigabyte tapes. The disk farm estimate includes disks, parity disks, Linux and RAID software, CPUs, motherboards, cases [27], power supplies, memory, Fast Ethernet PCI cards, Promise Ultra66 cards, Ethernet switches [24, 25], and racks. The Linux PC that runs each disk set costs about the same as a high end SCSI-to-PCI controller card.

To achieve a quarter Petabyte, 873 Linux PCs are required with eight 40.9 GB disks each. One eighth of the disk space is devoted to parity for data recovery from disk failure. Care must be taken to write protect files and disks to prevent accidental deletion. Physically, the PCs form a wall 4 high by 2 deep by 110 wide ( $2.4 \times 1.1 \times 24$  meters). Each Linux PC consumes about 90 watts, equally divided between the disks and the CPU/motherboard. A dozen 24000 BTU window air conditioners would suffice to remove this 80 Kilowatt heat load. Much less heat is generated in standby mode. The first level network consists of 288 \$75 fast ethernet switches [25]. A single high end switch with 288 fast ethernet ports is used for the network backbone [24]. The disks themselves can be used to transport data between sites. A high rate experiment might generate a Terabyte of data a day which one wished to move. A Terabyte fits on 25 disks, which easily fit in a suitcase for shipping.

In summary, the disk farm cost is not too much greater than the tape silo cost and the performance of the disks is far better. One also gets a Teraflop of computing power [28] as a free bonus; and the disk farm encapsulates data with instructions in physical computing objects which can be exploited to increase efficiency. Disk farm sizes can be scaled in size with great flexibility! Its sometimes difficult for a university to buy a whole tape silo [29]. Now everyone can have the benefit of online data.

Table 4: Comparison of a 250 TB EIDE disk array to a 250 TB StorageTek tape silo.

Storage System	Vol. m <sup>3</sup>	Avg. Power Kw	Avg. Access Time	No. of Disk or Tape Drives	I/O per Drive MB/s	Time to Read 250 TB	Purchase Price
EIDE RAID Disks	100	80	0.009 s	7000	20	34 minutes	\$2 100 000
STK Tape Silo	25	6	115 s	8	11	32 days	\$1 300 000

### Terabyte Arrays of IEEE–1394 FireWire Disks

The amount of disk space one can connect to a CPU directly with 18” EIDE cables is currently less than a Terabyte. In some applications, one might want to access more data with fast local disk and not suffer the overhead of network software. One may be able to use four IEEE–1394 FireWire buses [30] with a single CPU to attach up to 63 inexpensive EIDE disks per bus for a total of 10 Terabytes of local storage at 200 MB/s.

FireWire’s peer-to-peer topology also adds significant new functionality by allowing multiple computers to share multiple disks directly on a single bus.

Symbios Logic/LSI Logic has a \$13 IEEE–1394 to ATA/ATAPI controller chip [31]. The SYM13FW500 integrates a 400 Mbits/s IEEE–1394 (FireWire) physical interface (PHY) with an ATA/ATAPI interface, all on a low-power CMOS IC. Each SYM13FW500 supports two ATA/ATAPI devices. Wyle Electronics distributes the part. Recently, Oxford Semiconductor has also introduced an IEEE–1394 to ATA/ATAPI controller chip, the OXFW900 [32]. Texas Instruments has decided not to market their prototype IEEE–1394 to ATA/ATAPI chip.

EIDE disks with EIDE to IEEE 1394 FireWire interfaces are available from LaCie [33] and VST Technologies[34]. VST Technologies has also shown FireWire RAID arrays with mirroring and striping, but not parity [35]. All the disks are EIDE.

An interesting possibility might be to put eight EIDE drives in an inexpensive PC case with a 300 watt power supply. Then add four EIDE to FireWire interface chips to a circuit board with the same form factor as a PC motherboard. The color of the PC case can even be special ordered [27] for Apple Macintosh users.

Andreas Bombe, Sebastien Rougeaux, and Emanuel Pirker are in the process of writing GNU Linux software drivers for IEEE 1394/FireWire devices [36].

Pieces appear to be converging. It may, in the not too distant future, be possible to directly connect Terabyte arrays of EIDE/ATA disks to one or more computers at up to 50 Megabytes/second per FireWire interface. Some computers come with FireWire on the motherboard. FireWire interfaces can also be added with cards such as OrangeMicro’s HotLink FireWire PCI Board [37].

### REFERENCES

- [1] Friedhelm Schmidt, *The SCSI Bus and IDE Interface: Protocols, Applications,*

*and Programming*, Second edition, Addison–Wesley (1997) ISBN 0-201-17514-2.  
EIDE stands for Enhanced Integrated Drive Electronics.

- [2] [http://www.storagetek.com/StorageTek/hardware/tape/9310/9310\\_sp.html](http://www.storagetek.com/StorageTek/hardware/tape/9310/9310_sp.html)  
[http://www.storagetek.com/StorageTek/hardware/tape/SD3/SD3\\_sp.html](http://www.storagetek.com/StorageTek/hardware/tape/SD3/SD3_sp.html)
- [3] <http://www.shopper.com>  
<http://www.gateway.com/spotshop/> Validation Number BI444 10% off
- [4] <http://www.maxtor.com/diamondmax/40.html>
- [5] <http://www.storage.ibm.com/hardsoft/diskdrdl/desk/37gp34gxpdata.htm>
- [6] <http://www.seagate.com/cda/products/discsales/personal/family/0,1128,154,00.html>
- [7] <http://www.westerndigital.com/company/releases/990426.html>  
<http://www.westerndigital.com/products/drives/specs/wd273bas.html>
- [8] <http://www.western-digital.com/products/drives/specs/wd307aas.html>
- [9] [http://www.quantum.com/products/hdd/fireball\\_lct10/fireball\\_lct10\\_specs.htm](http://www.quantum.com/products/hdd/fireball_lct10/fireball_lct10_specs.htm)
- [10] <http://www.maxtor.com/diamondmaxplus/40p.html>
- [11] <http://www.seagate.com/products/discsales/discselect/A1a1.html>  
<http://www.seagate.com/cda/products/discsales/enterprise/family/0,1130,43,00.html>
- [12] [http://www.quantum.com/products/hdd/atlas\\_10k/atlas\\_10k\\_specs.htm](http://www.quantum.com/products/hdd/atlas_10k/atlas_10k_specs.htm)  
[http://www.quantum.com/products/hdd/atlas\\_10kii/atlas\\_10kii\\_specs.htm](http://www.quantum.com/products/hdd/atlas_10kii/atlas_10kii_specs.htm)
- [13] <http://www.storage.ibm.com/hardsoft/diskdrdl/ultra/36xpdata.htm>
- [14] <http://www.storage.ibm.com/hardsoft/diskdrdl/ultra/72zxdata.htm>
- [15] <http://www.seagate.com/products/discsales/discselect/A1a1.html>  
<http://www.seagate.com/cda/products/discsales/enterprise/tech/0,1131,214,00.shtml>
- [16] [http://www.quantum.com/products/archive/bigfoot\\_tx/bigfoot\\_tx\\_overview.htm](http://www.quantum.com/products/archive/bigfoot_tx/bigfoot_tx_overview.htm)
- [17] <http://www.storage.ibm.com/hardsoft/diskdrdl/desk/1614data.htm>  
<http://www.storage.ibm.com/hardsoft/diskdrdl/prod/14gx16gppr.htm>
- [18] <http://www.promise.com/Products/idecards/u66.htm>  
<http://www.promise.com/Products/idecards/u66compat.htm>  
<http://www.promise.com/Latest/latedrivers.htm#linuxu66>
- [19] <http://www.storage.ibm.com/hardsoft/diskdrdl/prod/ds25gp22.htm>
- [20] ProMAX, 16 Technology Dr., Irvine CA 92618 800–977–6629  
<http://www.promax.com/>

- [21] <http://www.firmtek.com> Chi Kim Nguyen ckn@firmtek.com
- [22] David A. Patterson, Garth Gibson, and Randy H. Katz (UC–Berkeley), *A Case for Redundant Arrays of Inexpensive Disks (RAID)*, Proceedings of the ACM Conference on Management of Data (SIGMOD), Chicago, Illinois, USA (June 1988) Pages 109–116.
- [23] Miguel de Icaza, Ingo Molnar, and Gadi Oxman, *The LINUX RAID-1,4,5 Code*, 3rd Annual Linux Expo '97, Research Triangle Park, North Carolina, USA (April 1997); <http://luthien.nuclecu.unam.mx/~miguel/raid>  
<http://linas.org/linux/Software-RAID/Software-RAID.html>  
<http://linas.org/linux/Software-RAID/Software-RAID-3.html>
- [24] We use the Lucent Cajun P550 Gigabit Switch with 23 Gigabits per second of switching throughput capacity to connect our Fast Ethernet computers. Up to six cards may be installed in this switch. One option is a card with 48 full duplex 10/100Base-TX ports.  
<http://public1.lucent.com/dns/products/p550.html>
- [25] One might quadruple the number of ports of a high end switch like the Cajun P550 by adding a commodity switch to each of its ports. Several Ethernet switches with 5 full duplex 10/100Base-TX ports cost under \$100. All feature a store-and-forward packet switching architecture to help reduce latency.
- |   |                  |      |
|---|------------------|------|
| <a href="http://www.addtron.com/">http://www.addtron.com/</a>   | ADS-1005         | \$69 |
| <a href="http://www.dlink.com/products/switches/dss5plus/">http://www.dlink.com/products/switches/dss5plus/</a>                 | DSS-5+           | \$90 |
| <a href="http://www.hawkingtech.com/">http://www.hawkingtech.com/</a>   | PN505ES          | \$79 |
| <a href="http://www.linksys.com/scripts/features.asp?part=EZXS55W">http://www.linksys.com/scripts/features.asp?part=EZXS55W</a> | EtherFast        | \$90 |
| <a href="http://netgear.baynetworks.com/products/fs105ds.shtml">http://netgear.baynetworks.com/products/fs105ds.shtml</a>       | FS105            | \$83 |
| <a href="http://smc.com/smc/pages.html/switch.html">http://smc.com/smc/pages.html/switch.html</a>                               | EZNET-5SW/6305TX | \$78 |
- [26] <http://www.redhat.com>
- [27] IW-Q600 ATX Full Tower Case, 11 bays, 300 watt power supply – \$77  
 Q600 case dimensions: 600mm high × 200mm wide × 432mm deep.  
 IW-Q2000 ATX Full Tower Case, 11 bays, two 300 watt power supplies – \$208  
 Q2000 case dimensions: 600mm high × 200mm wide × 476mm deep.  
 “Available in different color for OEM customers.”  
<http://www.in-win.com/framecode/index.html>  
<http://www.pricewatch.com>
- [28] Advanced Micro Devices and Pentium III CPUs can perform four single precision floating point adds or multiplies per clock cycle with their 3DNow! or Streaming SIMD Extensions units, respectively. Both 3DNow! and SSE are implementations of SIMD (Single Instruction, Multiple Data) processors.  
<http://www.amd.com/products/cpg/athlon/index.html>  
<http://www.amd.com/products/cpg/k6iii/index.html>

- <http://www.amd.com/products/cpg/k623d/index.html>  
<http://www.intel.com/home/prodserv/pentiumiii/prodinfo.htm>
- [29] For situations with more people than money, manually loaded tapes provide the way to store and move data with the lowest initial investment. The lowest media cost is given by 112 meter long 8mm tapes storing 5 Gigabytes uncompressed on an Exabyte Eliant 820 at 1 MB/s. The tapes cost 53 cents per Gigabyte at the Fermilab stockroom and the Eliant 820 tape drive costs \$1300. Used Exabyte 8500 and 8505 tape drives are even cheaper on ebay.com. Using pairs of drives, with one running and the other waiting on deck with a tape ready to go, gives operators time to load tapes [38, 39].  
<http://www.exabyte.com/products/8mm/eliant/>  
<http://www-stock.fnal.gov/stock/>  
<http://www.exabyte.com/products/>
- [30] *IEEE Standard for a High Performance Serial Bus*, ISBN 1-55937-583-3.  
<http://standards.ieee.org/catalog/bus.html#1394-1995>  
[http://standards.ieee.org/reading/ieee/std\\_public/description/busarch/1394-1995\\_desc.html](http://standards.ieee.org/reading/ieee/std_public/description/busarch/1394-1995_desc.html)
- [31] SYM13FW500 ATA/ATAPI to 1394 Native Bridge Data Manual Version 1.02  
<ftp://ftp.symbios.com/pub/symchips/1394>  
<http://www.symbios.com/news/pr/80330ata.htm>
- [32] <http://www.oxsemi.com/products/products.html>
- [33] <http://www.lacie.com/scripts/harddrive/drive.cfm?which=30>
- [34] VST Technologies, 125 Nagog Park, Acton, MA 01720 978-635-8282  
[http://www.vsttech.com/vst/products.nsf/pl\\_firewire](http://www.vsttech.com/vst/products.nsf/pl_firewire)  
<http://www.macnn.com/thereview/reviews/vst/fwhd.shtml>  
<http://www.elgato.com/products.html> FireWire Disk Control 1.01
- [35] <http://www.vsttech.com/vst/press.nsf/default> 08/31/99 09/17/99  
<http://www.softraid.com>
- [36] <http://eclipt.uni-klu.ac.at/ieee1394/>  
[http://www.kt.opensrc.org/kt19990722\\_28.html#15](http://www.kt.opensrc.org/kt19990722_28.html#15)
- [37] <http://www.orangemicro.com/firewire.html>
- [38] C. Stoughton and D.J. Summers, *Using Multiple RISC CPUs in Parallel to Study Charm Quarks*, *Computers in Physics* **6** (1992) 371.
- [39] S. Bracker, K. Gounder, K. Hendrix, and D. Summers, *A Simple Multiprocessor Management System for Event-Parallel Computing*, *IEEE NS-43* (1996) 2457; hep-ex/9511009.