

## Testing System Optimization and Design for Slurry Pipeline Transportation

Xiong Ting, Fan Shidong and Jiang Pan

Key Laboratory of High Performance Ship Technology of Ministry of Education,  
Wuhan University of Technology, Wuhan 430063, China

**Abstract:** This study aims to introduce the design and optimization of a testing system for the on the slurry pipeline transportation in dredging projects. Due to characteristics of slurries such as high concentration, irregular particles and complex ingredients, slurry transportation often subjects to huge pipe resistance, high energy consumption, pipe blockage and short transportation distance. Literature review indicates that the gas injection to pipeline can effectively improve slurry flow state and reduce pipeline resistance. However, the research on design and optimization of slurry pipeline transportation in dredging projects is scarce. Hence, this study has designed a new air-injected pipeline system for dredging projects. The general structure of the new system and new features of sub-systems have been introduced in details. In the design process, key parameters have been monitored, including the inner pressure, quantity of flow and flow state. These parameters have been used in measurement and control sub-systems, which are suitable for the dredging projects. The optimization and design results demonstrate that the designed air-injected pipeline system are reasonable in design, inclusive in functions and reliable in accuracy and can be applied to simulation of real conditions in slurry translation in dredging projects.

**Keywords:** Air-injected transportation, dredging projects, pipeline system, resistance reduction

### INTRODUCTION

Pipeline transportation has the advantages such as continual transportation, high efficiency, airtight non-pollution, easy installment and a few medium equipments (Bray *et al.*, 2007; Shen, 2010). Therefore, slurry pipeline transportation has become the main means in cutter suction dredge projects. In dredging pipeline systems, pipe diameter ranges from 200 to 600 or 700 mm, transportation distance extends from several hundred meters to several kilometers and transportation flow varied from 200 or 300 stere to several thousand steres every hour. Slurries are complicated in ingredients and unsteady in flow state, consisting of solid dielectrics like mud, sand and stone or other mixtures. The particle diameters scatter from a few micrometers and tens of centimeters and their volume concentration reaches up to 40-50% V/V. All above illustrate that working conditions in the slurry pipeline transportation depend on many parameters and undergo unsteady changes, easily resulting in technical problems like strong resistance, high energy consumption of dredge pump, easy blockage, severe friction on walls of pipes and short transportation distance. Such problems tend to bring about pipeline breakdown and interrupt dredging projects, limiting productivity. Hence, there exists a need for scientific researches on such realistic problems occurring in

dredging pipelines so as to reduce pipeline resistance and friction on walls of pipes and lengthen transportation distance as well (Tao *et al.*, 2006).

In recent years, gas injection on the pipeline transport of slurries has made fast progress, which started originally in chemical industry rather than in dredging projects and was mainly applied to transport high-concentration slurries. Lockhart and Martinelli (1949) firstly put forward injecting gas to the pipe in 1949. But they found gas injection had increased the pressure gradient in pipeline, in other words, gas injection had increased pipeline resistance (Lockhart and Martinelli, 1949). Afterwards, a sequence of related experiments was conducted by scholars and demonstrated that gas injection would result in resistance climbing. In late 1970s some scholars pointed out that gas injection would reduce the resistance if shear-thinning or pseudo-homogeneous slurries took the form of slug flow. Such phenomenon was first found out by Ward and Dallavalle (1954) and then by Oliver and Young-Hoon (1968). Similar finding also appeared when Mahalingam and Valle transported different types of Kaolin clay and trass (Oliver and Young-Hoon, 1968). Farooqi and Richardson (1982) also made researches on pressure drop analysis of two-phase gas-liquid flow in smooth horizontal pipes. They divided the two-phase gas-liquid flow into four types and built corresponding mathematical models to

evaluate the effect of gas on pressure gradient in the pipes. Heywood and Charles (1980) explored the effect of the two-phase flow between gas and non-Newtonian liquid on flow resistance in pipes, compared its pressure gradient with that of the one-phase liquid flow and offered resistance-reducing indicator in gas injection. Subsequently, (Heywood and Richardson, 1981; Heywood, 1999; Heywood and Alderman, 2003) made further researches on gas injection. Their gas injection researches were made on both horizontal and vertical pipes, including layer flow, turbulent flow, slug flow and laminated flow.

In 2005, another systemic research was conducted by Aluf (2005). He made improvement based on the models of Farooqi *et al.* (1980) turning the two-phase flow into the three-phase one and taking into consideration solids' settling and their fluidized beds' sliding at the bottom of pipes. He successfully established the first mathematical model applicable to gas-injected transport of both settling and non-settling Newtonian slurries, with larger scope of application compared to models in literature. His research comes to the conclusion that gas injection, whether for Newtonian or non-Newtonian slurries, reduces resistance in laminar conditions and turbulent conditions. What is more, there exists a critical value for slurry velocity (transport speed), the closer to which the better effect of the resistance reduction (Aluf, 2007).

In previous study involved with the research on the slurry pipeline transportation, we also have been dedicated to the resistance reduction of the air-injected pipeline transportation. We have found that under certain conditions air injection has good effect on slurry transportation. Meanwhile air also induces great influence on slurry flow states. Hence, monitoring the flow states after air injection has received considerable attentions. However, limited work has been done to design and establish related experimental/industrial used testing equipments to investigate the flow state changes. To address this issue, this study presents a new set of testing system to strengthen monitoring instantaneous flow state and provide resistance characteristics under corresponding flow state to deeply identify the applicable scopes of air injection and resistance reduction. The optimization and design of the new testing system have been implemented and it finds that the proposed new testing system can service as an experimental foundation for the resistance reduction of the air-injected pipeline transportation.

### TEST-BED FUNCTIONAL DESIGN

**Test objective:** Research shows that the internal resistance of pipes mainly depends on slurry characteristics, slurry concentration, slurry flow and corresponding flow state and pipe blockage is due to slurry settling in the course of transportation. Thus, test

objectives are mainly to analyze the flow states of different concentration slurries in pipeline transportation, take measurements of corresponding pipe pressure, make calculations of resistance along the pipe walls to get resistance curve. In addition, the test also aims to analyze the relations between resistance and parameters like slurry concentration, slurry flow, slurry particle diameter, so as to provide solutions to improve pipeline flow state and resistance reduction.

**Functional design:** In earlier stage this laboratory has conducted researches on slurry pipeline transportation and established two sets of air-aided pipeline transportation systems. The researches have proposed that air injection is helpful of reducing pipeline resistance and lengthening transportation distance. It has also been found out that great changes take place in slurries of different flow states and especially when the slurry has high concentration, air injection can improve slurry flow state and reduce pipeline resistance:

- **Test module for dredge cutter head simulation:** This module is an added one, aiming to simulate the dredging process in cutter suction dredge. This test can produce real procedures of cutter stirring slurry in slurry pool and then pump slurries out. Because the researched objects are supposed to be high-concentrated slurries, the pumped out slurries have to be first dehydrated to get concentration as high as possible and then be pumped into pipeline to get transported.
- **Test module for high-concentrated slurry transportation:** In order to meet the needs of transporting high-concentrated slurry, selection of pump is strictly required and here is selected screw pump for high-concentrated slurry. Slurry concentration scope can be adjusted in pump pool and this test requires 20 to 60% concentration slurry as transmission medium. Considering the simulation of different dredging conditions, frequency cabinet is used to vary motor velocity to keep the flow rate in control. Owing to the great influence of slurry flow rate on slurry flow state, an over-all simulation for different flow states in the test requires the scope of slurry flow velocities to be as wide as possible and then the laminar flow and turbulent flow could be tested in the slurry pipeline.
- **Test module for air-injected slurry pipeline transportation:** Researches prove that air injection can efficiently reduce pipeline resistance under certain scope but it sets a severe restriction on air injection. Air flow rate have be controlled in a stable and appropriate scope and the air has to be ensured a efficient resistance reduction to scatter on the pipe walls by uniformly mixing air and slurry through air injector. According to the

requirements, air-injected system has to give consideration mainly to the following aspects: firstly, air injector should have a reasonable design, air and slurry should be mixed uniformly and air had better to flow along the pipe walls. Secondly, air flow rate should be controlled by pressure regulating valve to make waves as small as possible. In this way, flow state could be stable in the internal pipe. Lastly, scope of air flow regulation has to be wide and available to get different data of flow states.

- Matching test module for slurry pipeline transportation:** The matching plan of this test mainly involves the following circumstances: with slurry transportation equipments and parameter of pipe diameter unchanged, system performance parameters should be matched; with pump flow rate and flow rate unchanged, different transportation pipe diameters have to be matched. In addition, since this test includes air injection section, it is needed to estimate the influence of test module for air-injected slurry pipeline transportation on the matching performance of present system. In other words, it is needed to test the influence of different air volumes and injecting ways on the system under the same system performance parameters. Or it is needed to set the parameters of test module for air-injected slurry pipeline transportation according to system matching performance.

### TEST APPARATUS DESIGN WITH MEASUREMENT AND CONTROL SYSTEM

**Pipeline layout of test apparatus:** According to the designed functions of test system, the previous test system has been modified and added one pipeline, with improvement on the control of slurry concentration and flow rate, as well as the accuracy in test system. The detailed layout is drawn in Fig. 1 and this test system has the following characteristics:

- The pipeline layout is optimized in the test and sharp turn pipes are reduced. Three test pipes are available for selection. They are  $\Phi 50$ ,  $\Phi 100$  and  $\Phi 200$  mm in diameter, respectively.
- The test pipes adopt seamless and stainless steel pipes and set a 2 m transparent organic glass, in order to make observations and high-velocity photography.
- Two injectors with same structure are designed for different flow paths to entrap air and contrasted in mixing efficiency. The structure of the air injector is shown in Fig. 2. Regarding the issue that gas flow is unstable in the past tests, this test adds air pressure regulating system. The whole air injection system is shown in Fig. 3.

#### The test system of test apparatus:

- Average regulation of slurry concentrations and observation system:** In this test system, slurry pool is adjustable in concentration and there

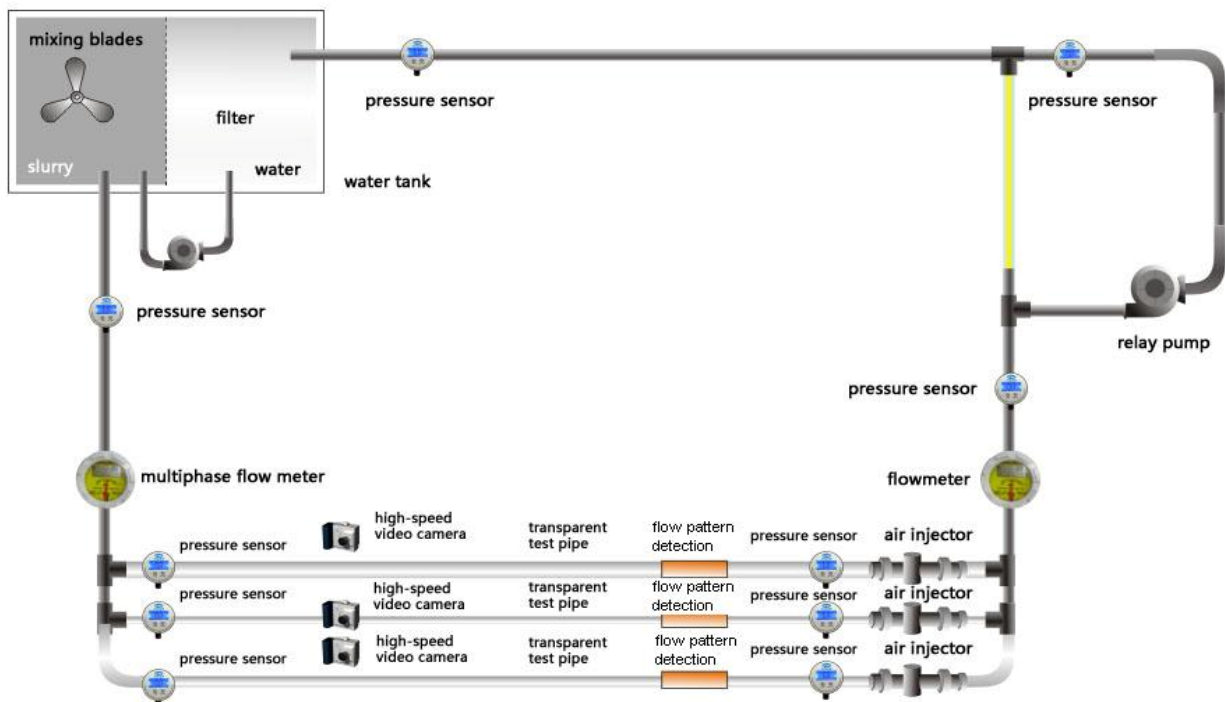

Fig. 1: Hydraulic circuit of the pipeline apparatus

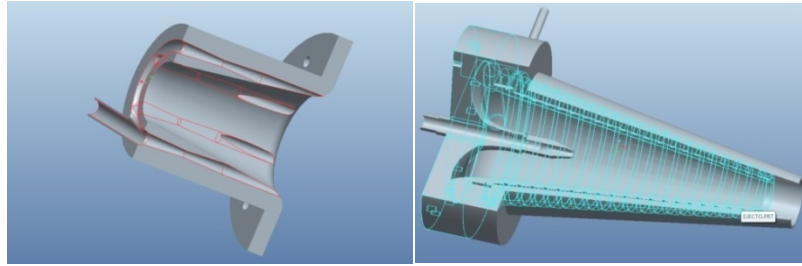

Fig. 2: Structure diagram of air injector

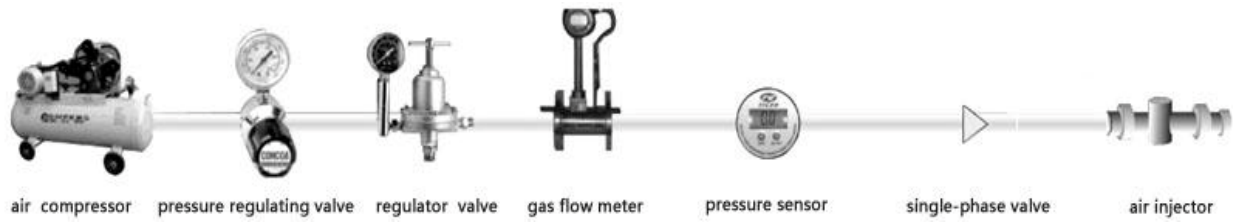

Fig. 3: Air injector system

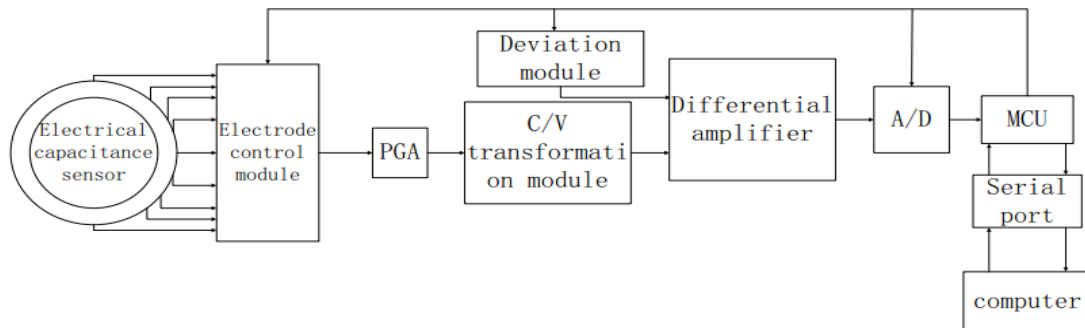

Fig. 4: Electrical capacitance tomography test system

is a clapboard and filter net in the middle. When the low concentration slurry is transported, clean water will be pumped into slurry pool from the clean water pool on the right side and the slurry concentration will lower. When the high concentration slurry is transported, the clapboard will be opened to allow the water to run through filter water into the clean water pool and naturally the slurry pool on the left side will have a higher concentration and then from the weighing system can be worked out the average slurry concentration of the slurry pool.

- **Observation system for instant concentration of slurry in transportation, which is shown in Fig. 4:** This system consists of three parts: capacitance sensor, data acquisition system and imaging computer. Because the phases of measured materials have different dielectric constant, the changes to flow volume fraction or concentration of each phase will bring about changes to dielectric constant of mixed fluid and accordingly capacitance between measuring electrodes will

vary. Based on that, calculation is re-made and the measured material is re-established its distribution map according to corresponding images. It is meanwhile acquired the parameters like instant flow rate and instant concentration of slurry on a certain cross section. Finally it is to calculate the settling velocity of slurry according to the tested parameters.

- **Observation system for flow state with high-speed photography:** Here uses the high-speed photographing camera to take pictures of instant slurry flow state in pipeline under different parameters and makes contrast with pictures by electrical capacitance tomography. Therefore, the system can testify the accuracy of electrical capacitance tomography system while making observations for flow states.
- **Observation system for pressure and flow rate:** Pressure sensors are set along the pipeline and the arrangement is shown in Fig. 1. Pressure sensors mainly monitor the pipeline pressure variations. Slurry flow states in the internal pipes are

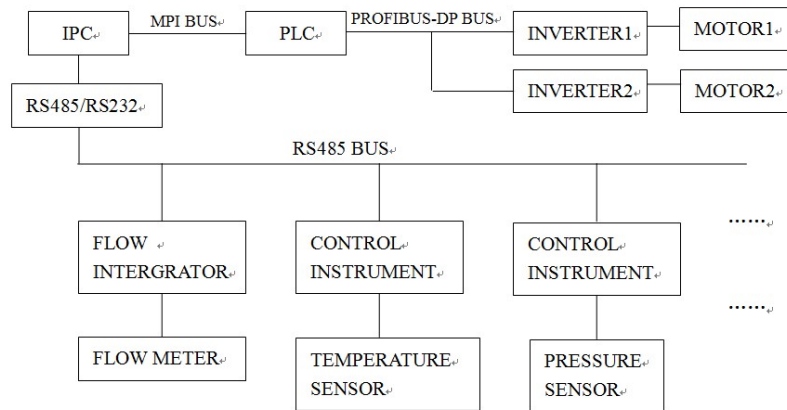

Fig. 5: The diagram of the control system

monitored by use of electromagnetic flow meter. The front end of pipe is installed fluid flow meter and the rear end of pipe is installed multiphase flow meter. Variations of slurry and air flow rates are monitored before and after the air injection.

**Control system of test apparatus:** The control system is a real time monitoring system based on PLC and AC frequency inverter and also a closed-cycle control system integrating in one all technologies of industrial control configuration, PLC, frequency conversion control, network service and intelligent control. The closed-cycle process mainly includes the following aspects. Firstly, the experimenters need to input in the PC the set values such as flow rate or pressure. Secondly, data from each sampling point are to have A/D conversion in flow integrator and control instrument and be shown in the meter of manual control cabinet. Meanwhile, they are transmitted through bus of RS485 and RS485/RS232 converter to industrial personal computer. Then the industrial personal computer will deal with these data and show the results on automatic operator to realize the objective of real time observation. Thirdly, the industrial personal computer is connected by MPI data bus to PLC and PLC is to compare the difference between set value and real value. Lastly, PLC controls the output frequency of frequency inverter through bus PROFIBUS-DP, so as to change the operating parameters of electric engine and to ensure a stable working condition in the course of testing. MPI (Multi-Point Interface) is used as the interface between CPU and PG/OP, or as the communication interface in the MPI subnet. Each CPU of SIMATIC S7-300 is installed a RS485MPI interface and its transmission rate is 187.5 K/s. PROFIBUS (Process Field Bus) is the field bus set by German national standard and European standard. PROFIBUS-DP here is used to transmit between scattered external

devices and automatic control equipments, or used as high speed data transmission. The diagram of the control system is shown in Fig. 5.

PLC is used to control how the system executes its programming logic control. The system adopts SIMATIC S7-300 313-2DP as the programmable controller. It is a small-size PLC system among the module ones, which can satisfy the middle-level performance requirement. Each functional module can well satisfy and adjust to the task of automatic operation. STEP7 is convenient to write the control program of PLC. The system adopts the special frequency inverters like Micro Master 430, the one with blower and water pump. Frequency inverter regulates the speed of pump by changing the power frequency and achieves the objective of ensuring stable flow velocity and pressure in spite of different working conditions in the tests.

## CONCLUSION

Based on the existed tests, this study sums up the characteristics and defects in the test apparatus of slurry pipeline transportation and takes a comprehensive consideration into many factors. Mainly focusing on the measurement and test for high concentration slurry, a new test apparatus is designed for pipeline transportation. It simulates the whole working process of cutter suction dredger from dredging; sucking to discharging and conducts experiments on the methods of transporting high concentration slurry, relay transporting and air-injected transporting. The test apparatus makes accurate observations on the flow states under different working conditions and the influence of air injection on the flow states. This test apparatus is reasonable in design, inclusive in function and reliable in accuracy, providing experimental bases to air-injected transportation and further researches.

#### **ACKNOWLEDGMENT**

This project is supported by the National Natural Science Foundation under Grant (No. 51179144) and Scientific Research Foundation of Wuhan University of Technology under Grant (No. 2012-IV-048).

#### **REFERENCES**

- Aluf, O., 2005. Experimental validation of a simple model for gas-liquid slug flow in horizontal pipes. *Chem. Eng. Sci.*, 60: 1371-1381.
- Aluf, O., 2007. The effect of gas injection on the hydraulic transport of slurries in horizontal. *Chem. Eng. Sci.*, 62: 6659-6676.
- Bray, R., A. Bates and J. Land, 2007. *Dredging: A Handbook for Engineers*. Butterworth-Heinemann Ltd., UK.
- Farooqi, S. and J. Richardson, 1982. Horizontal flow of air and liquid (Newtonian and Non-Newtonian) in a smooth pipe Average pressure drop. *Trans. Ins. Chem. Eng.*, 60: 323-333.
- Farooqi, S., N. Heywood and J. Richardson, 1980. Drag reduction by air injection for highly shear-thinning suspensions in horizontal pipe flow. *Trans. Ins. Chem. Eng.*, 58: 16-27.
- Heywood, N., 1999. Stop your slurries from stirring up trouble. *Chem. Eng. Prog.*, 09: 21-41.
- Heywood, N. and M. Charles, 1980. Effects of gas injection on the vertical pipeflow of fine slurry. *Proceedings of Hydrotransport, BHRA Fluid Engineering, UK*.
- Heywood, N. and J. Richardson, 1981. Head loss reduction by gas injection for highly shear-thinning suspensions in horizontal pipe flow. *Proceedings of Hydrotransport, BHRA Fluid Engineering, UK*.
- Heywood, N. and J. Alderman, 2003. Developments in slurry pipeline technologies. *Chem. Eng. Prog.*, 4: 100-107.
- Lockhart, R. and R. Martinelli, 1949. Proposed correlation of data for isothermal two-phase. Two-component flow in pipes. *Chem. Eng. Prog. Symp.*, 45(1): 39-48.
- Oliver, D. and A. Young-Hoon, 1968. Two-phase non-Newtonian flow II: Heat transfer. *Trans. Ins. Chem. Eng.*, 46: 116-122.
- Shen, Q., 2010. Analysis of the performances matched with construction equipment of cutter-suction dredger. *Ship Eng.*, 32: 126-130.
- Tao, S., K. Wang and J. Tao, 2006. A new system and installation to transport pliable loam and ooze. *Dong. Mar. Sci.*, 24(7): 114-120.
- Ward, H.C. and J.M. Dallavalle, 1954. Co-current turbulent-turbulent flow of air and water-clay suspensions in horizontal pipes *Chem. Eng. Prog. Symp. Series.*, 10: 1-14.