

ND:GLASS LASER DESIGN FOR LASER ICF FISSION ENERGY (LIFE)

John Caird¹, Vivek Agrawal², Andy Bayramian¹, Ray Beach¹, Jerry Britten¹, Diana Chen¹, Robert Cross¹, Christopher Ebberts¹, Alvin Erlandson¹, Michael Feit¹, Barry Freitas¹, Chuni Ghosh³, Constantin Haefner¹, Doug Homoelle¹, Tony Ladran¹, Jeff Latkowski¹, William Molander¹, John Murray¹, Sasha Rubenchik¹, Kathleen Schaffers¹, Craig Siders¹, Eddy Stappaerts¹, Steve Sutton¹, Steve Telford¹, John Trenholme¹, and Christopher Barty¹

¹Lawrence Livermore National Laboratory, 7000 East Ave., L-470, Livermore, CA 94551, email: caird@llnl.gov

²Coherent, Inc., 5100 Patrick Henry Drive, Santa Clara, California 95054

³Princeton Optronics, 1Electronics Drive, Mercerville, NJ 08619

ABSTRACT

We have developed preliminary conceptual laser system designs for the Laser ICF (Inertial Confinement Fusion) Fission Energy (LIFE) application. Our approach leverages experience in high-energy Nd:glass laser technology developed for the National Ignition Facility (NIF),¹ along with high-energy-class diode-pumped solid-state laser (HEC-DPSSL) technology developed for the DOE's High Average Power Laser (HAPL) Program and embodied in LLNL's Mercury laser system.²

We present laser system designs suitable for both indirect-drive, hot spot ignition and indirect-drive, fast ignition targets. Main amplifiers for both systems use laser-diode-pumped Nd:glass slabs oriented at Brewster's angle, as in NIF, but the slabs are much thinner to allow for cooling by high-velocity helium gas as in the Mercury laser system. We also describe a plan to mass-produce pump-diode lasers to bring diode costs down to the order of \$0.01 per Watt of peak output power, as needed to make the LIFE application economically attractive.

I. INTRODUCTION

The National Ignition Facility (NIF) is nearing completion at Lawrence Livermore National Laboratory (LLNL), and demonstration of deuterium-tritium (DT) inertial confinement fusion (ICF) ignition and burn is expected in the following year or two. As a result, interest in the potential of ICF-based energy production is increasing. Recently, a fusion-fission-hybrid energy-generation engine based on laser-driven ICF has been proposed. In addition to advantages of substantially increasing utilization of the nuclear fuel supply, reducing nuclear waste, and reducing the potential for weapons proliferation, the Laser ICF Fission Energy (LIFE) concept also reduces requirements for fusion energy gain, target yield, and drive laser efficiency.

II. SYSTEM OVERVIEW

In many ways, the NIF is a prototype for our LIFE laser concept. As with the NIF, the LIFE laser concept consists of a large number of individual beam lines or beamlets as shown for comparison in Figure 1. We plan to duplicate NIF's basic multi-pass architecture with a few minor modifications to optimize performance, as discussed in the following section. In addition, to enable high-average-power operation, we replace the NIF's passive cooling system with high-speed helium gas to remove heat from active laser components, as demonstrated in LLNL's Mercury laser. To achieve required laser efficiency >10%, we replace the NIF's flashlamps with a laser-diode pumping system (also demonstrated in Mercury). An increase in repetition rate by nearly five orders of magnitude results in average output power of order 100 kW per LIFE beamlet.

An enlarged cut-away view of the LIFE laser concept shown in Figure 2 identifies some of the challenges that we face in its development. The optics durability or lifetime, especially for optics near the target chamber (the "final optics") will determine availability of beamlets. We plan to have a number of extra beamlets so that their scheduled maintenance will not affect overall availability of LIFE power plants. Thermal energy management is an important issue for the laser amplifiers, the Pockels Cell switches, and the frequency converters, and will be discussed in more detail in Section V. Targeting accuracy requirements are stringent, but similar in precision and response time to other demanding systems currently under development. Maximizing efficiency and minimizing cost are also substantial, but manageable challenges.

III. PRIMARY DESIGN REQUIREMENTS

Various options being considered for the LIFE power plant concept have different laser requirements. Eight options, listed in Table 1, are classified by fusion yield

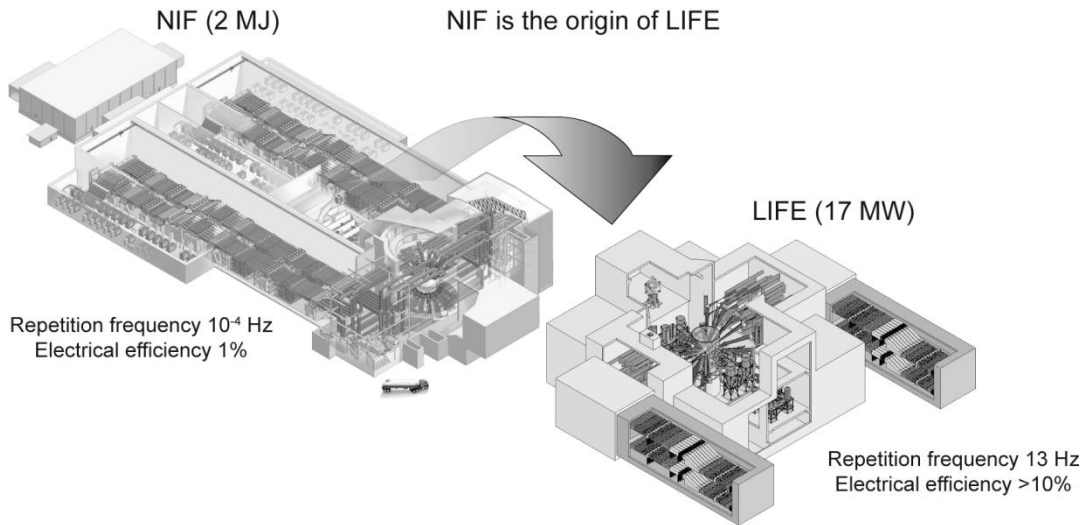

Figure 1. NIF configuration compared with LIFE concept.

(37.5 MJ or 75 MJ), method of ignition (hot spot ignition or fast ignition), compression laser wavelength (2ω or 3ω), and compression-laser illumination geometry (like NIF or low incidence angle (LIA)). Requirements for compression-laser pulse energy and peak power span large ranges. All eight options require laser operation at 13.3 Hz.

beams tightly to a common $\sim 50\text{-}\mu\text{m}$ spot diameter. Additionally, ignition laser beams must have high-intensity contrast ratio, with $<10^{11}\text{ W/cm}^2$ delivered on target prior to the ignition pulse to ensure efficient hot-electron generation and propagation to the core. As indicated in Table 1, ignition laser energy is 100 kJ for the 37.5-MJ yields, and 150 kJ for the 75-MJ yields.

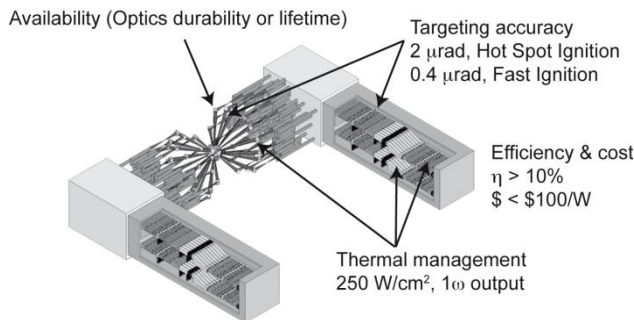

Figure 2. Cut-away view of the LIFE laser concept.

Two of the eight options use hot-spot ignition in which the temporal shape of the few ns-long compression laser pulse is tailored to cause shock wave heating of a small spot at the core of the compressed fuel to ignite the target.³ The remaining six options use fast ignition in which a compression laser of reduced size compresses the target, and a tightly focused ignition laser generates hot electrons and ignites the target.⁴ Of the six fast-ignition options, two use 3ω compression lasers with NIF-like illumination geometry, two use 2ω compression lasers with NIF-like illumination geometry, and two use 2ω compression lasers with LIA illumination geometry. All six fast-ignition options have the advantages of smaller lasers and higher target gain, achieved at the expense of generating short pulses of $\sim 20\text{-ps}$ duration and of focusing

Table 1. Compression-laser requirements for eight options currently under consideration.

Fusion Power (MW)	Fusion Yield (MJ)	Ignition Type	λ (μm)	Illumination Geometry	Energy (MJ)	Peak Power (TW)	Required Efficiency (%)
500	37.5	HSI	0.35	NIF-like	1.3	320	8.3
			0.35	NIF-like	0.35	51	3.0
		FI (100 kJ)	0.53	NIF-like	0.5	107	4.3
				LIA	0.62	130	5.1
1000	75	HSI	0.35	NIF-like	1.9	423	6.3
			0.35	NIF-like	0.63	139	2.6
		FI (150 kJ)	0.53	NIF-like	0.72	238	2.9
				LIA	0.89	300	3.5

HSI - hot-spot ignition
FI - fast ignition
 λ - compression laser wavelength
LIA - low-incidence angle

Since the target designs for the LIFE options have similarities with the indirect-drive NIF target designs, we expect other requirements for the compression-laser beamlines to be similar to NIF's. See Reference 3 for a detailed discussion of indirect-drive physics issues and requirements for the indirect-drive NIF laser design. For NIF, output power in each beamline must deviate from the desired power by $<8\%$ RMS over any 2-ns interval; the beams must be pointed to the desired locations on target with $<50\text{-}\mu\text{m}$ RMS deviation; pre-pulse on target must be $<10^8\text{ W/cm}^2$; overall pulse duration is 20 ns; the pulse must be temporally shaped, starting with a long, low-power "foot" portion and ending with a high-power "main" portion; and energy must be delivered within a $600\text{-}\mu\text{m}$ spot diameter. In the NIF illumination geometry,

the two ends of the cylindrical hohlraum target are illuminated with cones of beams at angles of ~ 30 and ~ 50 degrees with respect to the axis, with $2/3$ of the beams on the outer cone and $1/3$ on the inner cone. Beams are smoothed temporally and spatially, using smoothing by spectral dispersion (SSD).⁵ For the LIFE concept, the target illumination requirements must be met with a moving target, which is injected at a speed of several 100 m/s.

In the LIA illumination geometry used by two of the options, the two ends of the cylindrical hohlraum target are illuminated with one or more cones of beams subtending < 20 degrees (full angle) at the target. The LIA geometry uses fewer beam ports, which simplifies the design and fabrication of penetrations through the target chamber and fission blanket. However, it is anticipated that various inefficiencies of the LIA geometry will increase the required laser pulse energy by $\sim 20\%$, relative to the NIF-like illumination geometry.

A rule of thumb for economical fusion power plants is that the product of the laser wall-plug efficiency, η , and the fusion target gain, G , be greater than 10 to limit the electrical power recycled to drive the laser.⁶ To estimate required laser wall-plug efficiency for the LIFE concept, we have replaced the fusion gain with the product of the fusion gain and the fission gain. As shown in Table 1, required laser wall-plug efficiencies generated using this rule span from $\sim 3\%$ to 12.6%. As discussed in Section VII on laser efficiency, we believe that efficiencies greater than 12.6% can be readily achieved.

IV. BASELINE MULTIPASS ARCHITECTURE

We adopted the NIF beamline architecture for the LIFE laser because it has performance advantages relative to other architectures, it is well engineered and tested, and it has demonstrated reliable performance for the 192-beamline NIF laser.⁷ Since the LIFE laser operates at 13.3 Hz while the NIF laser operates at a few shots per day, designs for the amplifiers, Pockels cell switches, and harmonic converters have had to be modified to improve efficiency or to handle waste heat. These modifications are described in the various sections below and include flowing He gas over thin laser slabs and Pockels cell and frequency conversion crystals. To reduce Pockels cell switching voltage, improve pumping efficiency and to reduce vibrations of the laser slabs, the beam aperture for the LIFE amplifiers was reduced to 20×40 cm, compared with 40×40 cm for NIF. Additional advantages of using a smaller aperture include reduced losses due to amplified spontaneous emission (ASE) in the laser slabs, higher overall efficiency, and reduced costs for fixtures needed to fabricate optical components. A smaller aperture in the 1ω amplifiers allows them to operate far above the saturation fluence for efficient energy extraction, while beam expansion prior to

frequency conversion allows the final optics to operate well below their damage threshold.

Figure 3 is a schematic of the LIFE laser beamline preliminary baseline design. Pulses from the front end are injected in the far field of the transport spatial filter. After being collimated by the transport spatial filter lens, the beam passes through the booster amplifier, reflects off a mirror, reflects off the polarizer, and passes through the Pockels cell, cavity spatial filter, and cavity amplifier. After reflecting from the cavity end mirror, which might be a deformable mirror for correcting wave-front distortion, the pulses pass a second time through the cavity amplifier, cavity spatial filter, and Pockels cell. As the Pockels-cell voltage has been applied by this time, the Pockels cell rotates the beam polarization by 90° , and the beam is transmitted through the polarizer. After reflecting off from the second cavity end mirror, the beam passes through the polarizer, Pockels cell (which rotates the polarization back to its original orientation), cavity spatial filter, and cavity amplifier again. After reflecting from the first cavity end mirror again, the beam makes a fourth and final pass through the cavity amplifier, cavity spatial filter, and Pockels cell, which is now at low voltage and does not rotate the beam polarization. The beam reflects off the polarizer, reflects off a mirror, and passes a second time through the booster amplifier. It propagates through the transport spatial filter, where it is magnified anamorphically to $40 \times 40\text{-cm}^2$ aperture size, then through the harmonic converter and the final telescope, before being focused onto the target. A narrow constriction in concrete or some other neutron-absorbing material near the focal plane of the final telescope serves as a neutron “pinhole” that shields all laser optics except the final focus lens from fusion neutrons.

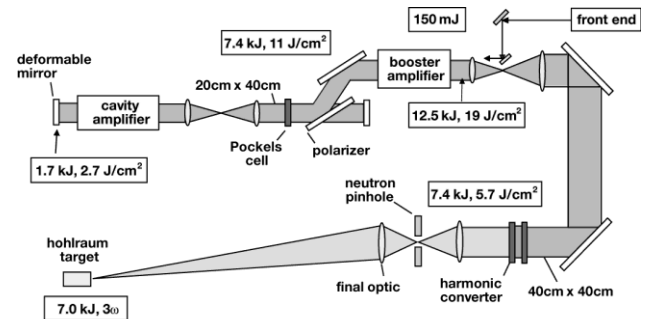

Figure 3. The LIFE baseline design is similar to NIF’s.

Some advantages of multi-passing the main amplifier include increased extraction efficiency, elimination of preamplifier sections that would add cost and increase building space, and reduced front-end size. Four passes are sufficient for achieving most of the benefits available from multi-passing as the required front-end energy is < 1 J. At this energy, cost of the front end is small relative to the cost of the rest of the system. Two passes would be

insufficient, however, since the required front-end energy would be >100 J, and front-end costs would be many times larger. Achieving four passes with this architecture has the added cost of using a full-aperture Pockels cell switch.

Like the NIF, the LIFE beamline relays the image of an apodized aperture in the front end to multiple locations through the chain to reduce the growth of diffractive noise.⁸ Also, the focused beams propagate through a different spatial-filter pinhole on each pass to avoid “pinhole closure” effects due to plasma blow-off from prior passes.⁹ Absorbing beam dumps must be placed at various locations to absorb stray beam light and light produced if Pockels cells misfire.

Output energies and fluences provided in Figure 3 correspond to limiting the nonlinear phase shift or ΔB (pronounced “delta-B”) accumulated between spatial filter pinholes to 1.8 radians, the same limit applied in the NIF design.¹⁰ ΔB , which is proportional to the beam intensity integrated along the beam path, has been correlated with the growth of small-scale intensity features, resulting in beam self-focusing. The numbers of laser slabs in the cavity and booster amplifiers have been adjusted to 10 slabs and to 5 slabs, respectively, to give the largest ΔB -limited output energy for 6-ns square-in-time pulses at 1ω . ΔB limits are attained nearly simultaneously in both the cavity-amplifier and booster-amplifier sections. The 6-ns square-pulse duration corresponds to the effective 1ω pulse duration needed to produce the required pulse energy and peak power at 3ω , for the 1.3-MJ, 3ω hot-spot ignition option listed at the top of Table 1. Approximately 185 laser beams will be required to meet pulse energy and peak power requirements for that case. Optical damage risk can also limit beam performance, as discussed in Section IX.

V. THERMAL ENERGY MANAGEMENT

Thermal energy is deposited in glass laser slabs due to non-radiative transitions between Nd^{3+} energy levels. It is also deposited in deuterated potassium di-hydrogen phosphate (DKDP) Pockels cells and optical harmonic conversion crystals due to residual hydrogen impurity absorption at the fundamental 1.05- μm wavelength. Heat is removed from these optics by transfer to high-velocity helium gas flowing in channels between the “slablets” as depicted in Figure 4. As heat in the optics flows toward their surfaces, the temperature is highest in their center and lowest at their surface. Thermal expansion of the center of the optics then puts the surfaces into mechanical tension. At the surface, residual cracks from the optics finishing process can propagate and lead to catastrophic crack growth if the tensile stress exceeds a critical value that depends on the material’s fracture toughness. Surface tensile stress is reduced by reducing slablet

thickness, thereby reducing the temperature differential between the center of an optic and its surfaces.

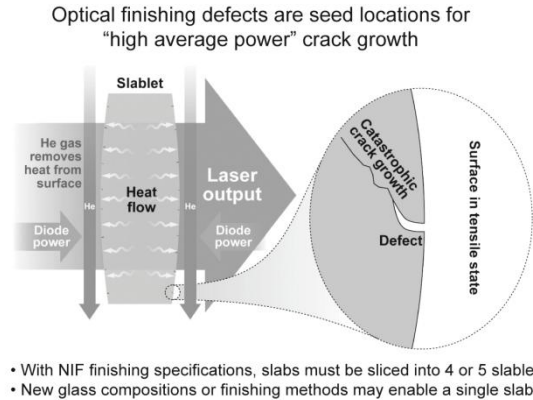

Figure 4. Heat removal concept for optics. Surface curvatures and implied thermal lensing are exaggerated to illustrate thermal tensile stress.

Control of thermal gradients and their effects on wavefront distortion and beam depolarization is also important. Contributions by Pockels cells and harmonic converters can be kept small by using highly-deuterated DKDP crystals, to reduce absorption of laser light and its associated heating. Preliminary finite element calculations show that contributions by laser slabs can also be kept small, by pumping slabs uniformly and by flowing cooling gas uniformly over slab surfaces. When pump-light distributions are non-uniform, however, significant wavefront distortion and depolarization can occur. Some pump non-uniformity may be advantageous. For example, laser efficiency can be increased by distributing pump light away from the edges of the slab where the extracting beam does not propagate. Greater wavefront distortion can be tolerated by using a deformable mirror to correct wavefronts. Similarly, greater depolarization can be tolerated by applying birefringence-compensation techniques. Detailed modeling to optimize tradeoffs between beam quality and efficiency, taking into account possible wavefront-correction and birefringence-compensation methods, will be an important part of the detailed laser design process.

V.A. AMPLIFIERS

A schematic of our preliminary conceptual design for a Nd:glass LIFE laser amplifier is shown in Figure 5. With the current composition of NIF amplifier glass and its finishing specifications (i.e., scratch-and-dig limits), we find that the amplifier slabs should be reduced in thickness to eliminate the potential for surface crack growth during high-average-power operation. Thus, NIF amplifier slabs, normally 4-cm in thickness, are thinned into five slablets of 8-mm thickness each, as shown in Figure 5. Windows are added beside the outer slablets to

contain the high-speed helium cooling gas flow. Laser diodes operating at 872-nm wavelength pump directly into the $^4F_{3/2}$ upper laser level of Nd^{3+} . The pump diode arrays operate at a spatially averaged, temporal peak irradiance of 5.2 kW/cm^2 . The total peak diode power is 6 MW on each side of the amplifier. A solid-model concept of a 4-stack amplifier, line replaceable unit (LRU), is shown in Figure 6, along with a cut-away view of an individual amplifier in which the helium flow channels can be seen.

The need to use thinner amplifier slabs is driven by the relatively low thermo-mechanical fracture-toughness of the NIF's current phosphate glass compositions and the current scratch-and-dig finishing specifications. We think that new glass compositions and/or advanced finishing technology can change or eliminate the requirement to reduce slab thickness. The development of new glasses and finishing technology will be part of the LIFE Laser development process.

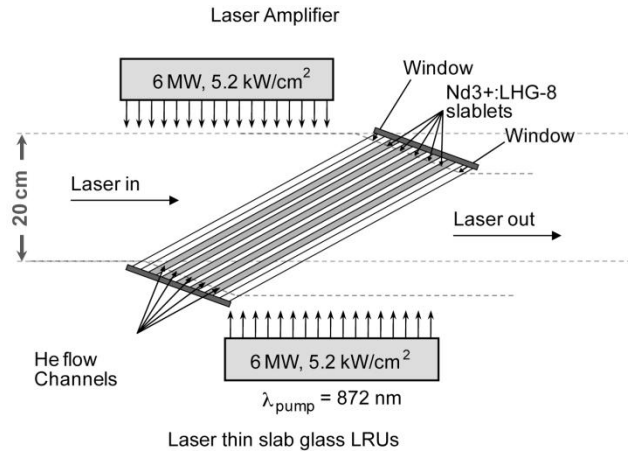

Figure 5. Five 8-mm slabs replace NIF 4-cm-thick slab.

Amplifier Line Replaceable Unit (LRU) concept has been developed

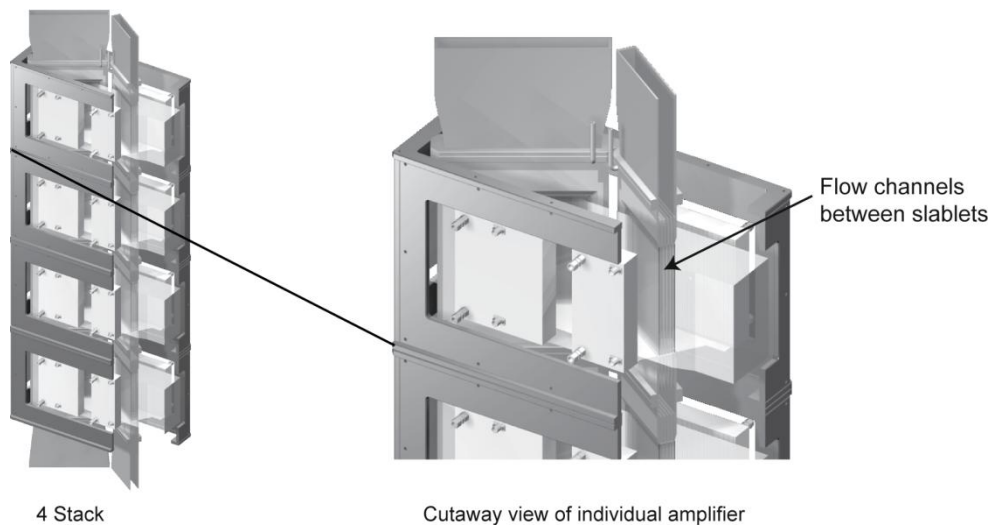

Figure 6. Model of 4-stack amplifier LRU, left, and cutaway view of amplifier with flow channels, right.

V.B. POCKELS CELLS

Efficient extraction of the energy stored in the main amplifier is achieved with a Pockels cell or electro-optic switch. A Pockels cell is simply an electrically driven switch that controls the polarization state of light passing through it. When coupled with a polarizer, the light path is altered, allowing multi-pass extraction.

The operating voltage and thermal loading constrain the design of the Pockels cell. The voltage required to rotate the polarization by 90° is known as the half-wave voltage. In a transverse Pockels cell (where the applied voltage is orthogonal to the light propagation direction), the half-wave voltage is proportional to the distance between the electrodes and inversely proportional to the

crystal thickness. The Pockels cell is designed with the constraints of ensuring that the drive voltage required to switch the device falls within the realm of possibility for the desired repetition rate and that the center-to-edge thermal gradient in the Pockels cell crystal is below the fracture limit of the crystal. The design criteria of an aperture-scalable, He gas-cooled, high-average-power switch has already been discussed.¹¹ For the electro-optic crystal, we propose using DKDP with a deuteration level between 95 – 99.9%. DKDP exhibits a residual near-infrared optical absorbance, which varies between $0.003/\text{cm}$ and $0.001/\text{cm}$, for 95% and 99.9% deuterated crystals, respectively.¹² In contrast to the gain medium, the thermal load on the Pockels cell is quite modest and

can be readily removed by near room temperature, room pressure subsonic helium flows.

The Pockels cell consists of 4 DKDP crystals with a thickness of 0.85 cm for the 99.9% D case. To eliminate static birefringence, each individual DKDP crystal is matched in thickness to one another within a few microns. While this represents a strenuous optical specification, these tolerances are met on crystalline parts machined using diamond turning and magneto-rheological finishing. Solid-state high-voltage power supplies, similar to the supplies already used for the plasma electrode Pockels cell on NIF, have already demonstrated operation at 10-Hz repetition rates and can be scaled to the necessary (80-kV) voltage.

Additional large aperture optics, in addition to DKDP, are required. The incident horizontally polarized light must be rotated 45 degrees both before and after the Pockels cell crystals. In addition, the equivalent of a 90 degree optical rotator must be used in the center of the Pockels cell. Two crystals are potentially available as the basis of these optical elements. Hydrothermally grown quartz is available with apertures of approximately 20 cm, whereas the current design requires a 40- × 20-cm aperture. While it is likely that hydrothermally grown quartz can be scaled to the final aperture, quartz can be easily optically bonded to provide a segmented window of the desired aperture. In addition to quartz, high optical quality sapphire is currently available in the desired aperture. Again, precision magneto-rheological finishing of sapphire will allow the manufacture of large aperture waveplates necessary for the Pockels cell operation.

V.C. FREQUENCY CONVERSION

DKDP of similar deuteration level to that of the Pockels cell (95% - 99.9% D) can also be used for the frequency doubler and frequency tripler. Thermal loading in the doubler and tripler is due, as in the Pockels cell, to residual infrared absorption. In contrast to the Pockels cell, as the infrared light is doubled and tripled, the crystal thermal loading decreases. We again propose a He gas-cooled segmented aperture, the design criteria of which have been previously discussed.¹³ Similar to NIF, we propose to use a Type I doubler/Type II tripler. While frequency conversion lowers the expected thermal loading, the generation of ultraviolet light leads to potential optical durability issues for the DKDP tripler crystals. To design around this, we expand the beamline aperture of the infrared light, so that when converted, the 3ω fluence will be below the damage limit. Again, the thickness of the doubling and tripling crystals is chosen to keep the center-to-edge thermal gradient less than 1°C , and results in a dual crystal doubler and tripler with 0.8-cm-thick DKDP crystals. As a potential alternative to DKDP, we are also developing crystals such as yttrium calcium oxyborate (YCOB). YCOB is currently used on

the Mercury laser system for high average power doubling.² We are currently looking at the possibility of scaling the aperture of YCOB beyond the current 7.5 cm width × 25 cm length.

VI. PUMPING BY LASER DIODES

NIF's flashlamp pumping of the main slab amplifiers will be replaced with arrays of laser diodes in the LIFE laser. This allows LIFE to take advantage of an order of magnitude increase in electrical-to-optical energy conversion efficiency, as discussed in the following section.

While increases in laser diode efficiency and power make this development technologically feasible, it would not be economically feasible without a substantial reduction in the cost of laser diodes. Fortunately, laser diode costs are dropping rapidly as the market for their use grows. Figure 7 shows that diode costs exhibited a 60% learning curve (i.e., prices dropped to 60% of their previous value for each doubling of the cumulative number of 100-watt bars produced) through acquisition of diodes to pump LLNL's Mercury laser in 2003. Cost estimates made more recently (points above 10^6 bars in Figure 7) lead us to expect this trend to continue through production of approximately 20 GW of diode power needed to construct a LIFE demonstration power plant.

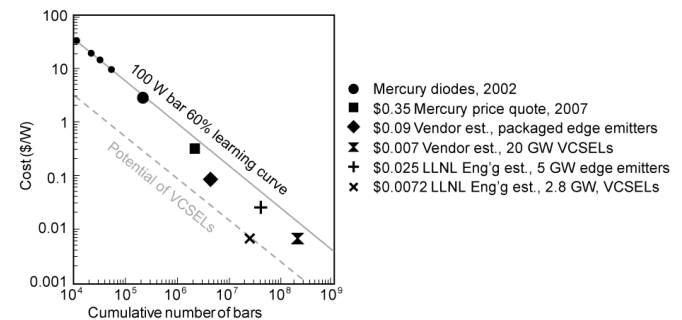

Figure 7. Diode cost learning curve.

At present, two primary candidates for laser diode technology are potentially applicable to LIFE. These are edge emitters, and Vertical Cavity Surface Emitting Lasers (VCSELs), as depicted schematically in Figure 8. To date, edge emitters have exhibited higher efficiency than VCSELs, and they are used in a majority of high-power laser applications. VCSELs, on the other hand, have the advantage of being fabricated in two-dimensional gallium arsenide (GaAs) wafer-scale arrays, compared to edge emitters' one-dimensional diode bars. This is expected to allow VCSELs to be manufactured more cheaply as their technology matures. An additional advantage of VCSELs is reduced irradiance at the output surface, which should provide enhanced durability.

The cost estimates shown in Figure 7 include three for edge emitters and two for VCSELs. One of the VCSEL estimates is due to a LLNL engineering study that projected a cost of \$0.0072 per Watt of peak diode power for 2.8 GW of laser diode manufacturing. This is an order of magnitude below the learning curve for edge emitters, and indicates the potential for dramatic cost reductions that could be achieved with this technology.

The potential of cost reductions for manufacturing VCSEL diodes can be better understood by comparison with the process for making GaAs integrated circuits (ICs) in the cell phone industry. There are a half-dozen or so high frequency GaAs ICs in every cell phone. The growth of GaAs crystals, production of wafer substrates,

epitaxial growth and patterning of layers is very similar to VCSEL production technology. If one estimates the cost per unit area of GaAs IC chips and divides by the power per unit area of VCSEL diodes, the answer is in the neighborhood of \$0.01 per Watt, in good agreement with cost estimates for high volume VCSEL manufacturing. Moreover, an estimate of the total volume of GaAs ICs produced to date shows that the area of GaAs substrates used in the world's two billion cell phones already exceeds that needed for the first LIFE demonstration power plant by an order of magnitude.

a) Edge Emitters

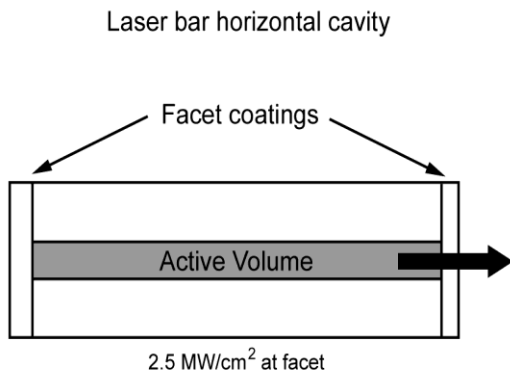

b) Surface Emitters

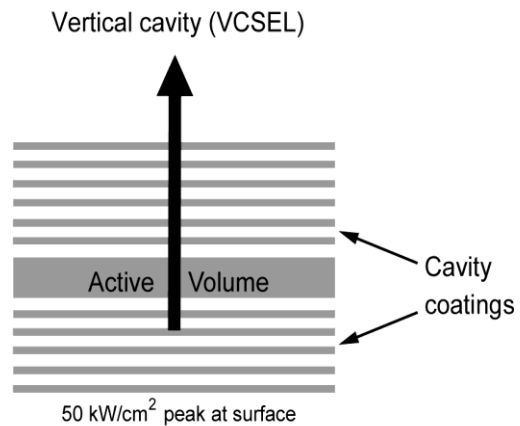

Figure 8. Edge emitter diode, left, and VCSEL diode, right.

VII. DRIVE LASER EFFICIENCY

We have compared our estimate for the efficiency of possible future LIFE 3ω laser drivers with the efficiency of the NIF laser and with estimated efficiency of the NIF laser with diodes replacing the flashlamps. See Table 2 for the results.

The NIF is strongly affected by losses associated with flashlamp pumping. These losses have been modeled extensively and are well understood.¹⁴ First, electrical energy is lost in the high-voltage power conditioning system. Next, flashlamps convert electrical input power to optical output power quite efficiently. However, much of their highly divergent output misses the laser slabs (affecting pump transport efficiency) or falls outside the Nd^{3+} absorption bands (affecting absorption efficiency). Since a large fraction of the absorbed flashlamp light is in the visible or near ultra-violet, the quantum defect (ratio of laser photon energy to average pump photon energy) is large, and the corresponding efficiency factor is low. Also, more than half the excited Nd^{3+} ions pumped by

Table 2. Diode pumping allows NIF laser technology to meet LIFE efficiency requirements.

Efficiency (%)	NIF (3ω) Lamp- Pumped	NIF (3ω) & Diodes Today	LIFE (3ω) & Diodes
Power Conditioning	82	88	90
Diodes / Lamps	50	60	80
Pump transport	63	98	99
Absorption	40	98	99
Quant Defect	60	83	83
1 - Decay Fraction	45	50	60
Extraction, Fill & 1ω Transport	37	37	60
Freq Conv & 3ω Transport	64	64	70
Cooling	100	100	90
Total Efficiency (%)	0.66	5.0	13.3

flashlamps decay during the pump pulse through spontaneous emission, non-radiative decay processes, and ASE. Of the energy stored in the laser slabs at the end of the pump pulse, only some 37% ends up as 1ω output when NIF is operated at 3ω . Although NIF has shown that up to ~52% of the stored energy can be converted to 1ω output energy (for 2ω operation), the extraction efficiency for 3ω operation is lower since 1ω output energy be reduced to protect optics from 3ω damage. The harmonic conversion efficiency of ~64% is limited by the need to generate 3ω light over a broad range of intensities, including a low-intensity “foot” pulse and a high-intensity “main” pulse required for efficient target compression.³ Finally, since NIF is fired only several times a day, little energy is lost to the cooling system. The estimated overall wall-plug efficiency for the NIF operating at 3ω is just 0.66%.

Replacing the flashlamps with diodes available today would increase the wall-plug efficiency of the NIF laser by over seven fold, to ~5%. The power conditioning system can be ~90% efficient, using distributed power supplies with close proximity to diodes. Diodes with electrical-to-optical conversion efficiency of over 70% have been demonstrated,^{15,16} although 60% seems to be available from commercial products. Diode light, being highly directional, can be directed onto laser slabs with high efficiency. By selecting glass with sufficiently high Nd^{3+} -doping concentration, absorption efficiency can be near unity. The efficiency due to quantum defect, 83%, is greater than for flashlamps and relies on pumping at 872 nm, the longest-wavelength pump band. Modeling shows ~50% of the excited ions decay when the diode pump pulse is ~365 μs . The extraction efficiency and harmonic conversion efficiencies are the same for diode-pumped NIF as for the current NIF.

With anticipated technology improvements, we estimate that the wall-plug efficiency of future LIFE lasers can be >13%. For example, within the next decade or two, it seems likely that diodes meeting the 80% efficiency goal of the DARPA SHEDS Program will become available.¹⁷ As diode costs come down, it will be possible to purchase more diodes and to pump the laser slabs with shorter pump pulses, so that up to 60% of the pumped ions remain excited at the end of the pump pulse. Up to 60% of the stored energy might be converted to 1ω output energy by extracting the stored energy in two sequential pulses rather than in a single pulse. The higher extraction efficiency derives from the fact that two sequential pulses, having twice the time duration as a single pulse, have lower values for intensity, peak power, nonlinear phase shift, and optical damage risk than a single pulse at the same overall fluence. Since higher fluences can be safely propagated in the two-pulse format without exceeding limits for nonlinear phase shift or damage risk, greater extraction efficiency can be

obtained. This advantage comes at the expense of having to separate the two pulses and to propagate them along separate paths such that they arrive at the target simultaneously, however. Harmonic conversion efficiency might be increased by generating the low-intensity foot pulses and high-intensity main pulses with separately optimized harmonic converters. Modeling shows that power consumed by systems for cooling the laser slabs, diodes, and other components are likely to reduce overall efficiency by ~10%.

VIII. OPTICS FABRICATION

The LIFE laser uses a number of different optics including amplifier glass, lenses, mirrors, windows, and Pockels cell and frequency conversion crystals. The specific optics were chosen because of modeling and manufacturability to provide the least expensive optics that meet performance requirements. Optics fabrication for the LIFE laser directly benefits from NIF Project experience. With help from optics vendors, NIF has developed fabrication processes for very large, high quality optics, as seen in Figure 9. The size and shape of all of the LIFE optics has been achieved or exceeded by the NIF Project. Improved finishing processes may be necessary due to the increased number of surfaces per beamline. Routine testing of optics will ensure that all LIFE requirements are met.

The gain medium for the LIFE amplifier slabs is neodymium-doped phosphate laser glass, similar in composition to the glass used in the Nova, Omega and Omega EP, Beamlet, and NIF lasers. The full aperture area ($40 \times 40 \text{ cm}^2$, oriented at Brewster’s angle for a $20 \times 40 \text{ cm}^2$ clear aperture) required for the LIFE laser amplifier material has already been achieved for Nd:phosphate laser glass, and production techniques are in place for the NIF.¹⁸ As in NIF, ASE-absorbing edge claddings must be attached to slab edges to reduce fluorescence decay rates and to prevent internal parasitic lasing. Several edge-cladding concepts, including both surface absorbers and volume absorbers, seem promising for meeting requirements for thermal heat loading and for low reflectance. The current bulk quality and finishing of the Nd:phosphate laser glass fully meets the NIF requirements. The LIFE laser will also require many different lenses, mirrors, and windows. The NIF Project has already achieved the size and shape of each of the LIFE optics. Techniques such as Magneto-Rheological Finishing (MRF) have been more fully developed in the last few years to improve the surface finish and reduce wave-front distortion of optics.¹⁹ The MRF technique does not induce subsurface damage and can effectively remove existing damage to create a more robust optical surface. This is just one of the advanced finishing methods that will be explored.

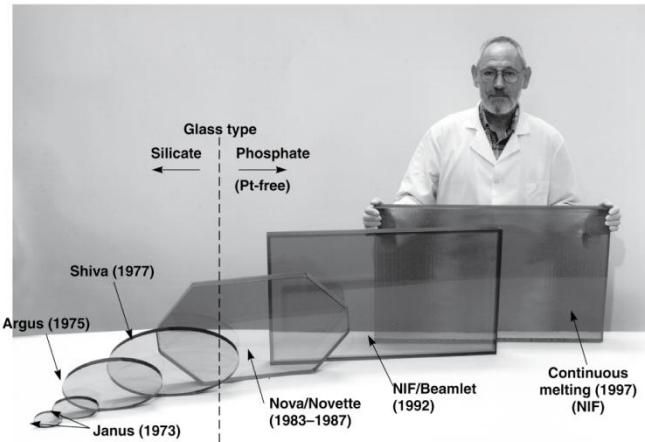

Figure 9. Optics developed at LLNL for various lasers, left, and continuous-pour laser glass production used for NIF, right.

IX. OPTICS DURABILITY

The design, construction, and completion of the NIF have led to rapid improvements in reliability of optical components exposed to high fluence.²⁰ Among the important advances are understanding and controlling the polishing process,²¹ conditioning of optics prior to employment,^{22,23} mitigation of damage growth,²⁴ theoretical exposition of the statistics of damage in large aperture optics.²⁶ All this knowledge and these techniques are directly applicable to, and will be used in the LIFE laser development process.

Despite the successes in NIF, LIFE will face some new challenges due to the high repetition rate that leads to the optical components being exposed to high average power, a high number of shots, and thermo-mechanical stress. The high average power requires high deuteration levels for the KDP in the optical switches and frequency conversion elements to reduce absorption. The reliability of highly deuterated KDP needs to be investigated more thoroughly. A high shot count is an issue because there has been some evidence that fatigue can lead to a reduced damage threshold under some conditions.²⁷ Compaction in the bulk or in sol-gel or hard coatings, especially of the UV exposed components, may also be an issue. Thermo-mechanical stress could cause damage sites to grow by crack propagation under conditions where they would not grow in the absence of stress. Another area of concern is the exposure of the final optic to a high average flux of neutrons.²⁸ Work on all these issues will continue. A facility for accelerated life testing of optical components is being planned. Little work has been published on very long-term reliability of laser optics, but at least one paper reports on the survival of high reflector mirrors for several billion shots.²⁹ The outlook for the development of the required high reliability optics is encouraging.

X. DEVELOPMENT PATH

Turning our concept for LIFE into reality will require substantial technological development in the coming decade. For example, a crucial element of the required development is the National Ignition Campaign (NIC), which is ongoing and is expected to demonstrate fusion ignition by ca. 2010. The viability of Fast Ignition will be tested on NIF in years that follow, with potential verification by ca. 2014. Other crucial elements include target fabrication, target injection, the fusion-fission “engine”, and the laser driver. We envision laser driver development progressing through several stages, beginning with design and testing of prototype laser components, especially the amplifiers, Pockels cells, and frequency converters. Next, a prototype LIFE Laser beamline or bundle that uses the developed components would be built and tested.

A key element of the LIFE Laser development plan must be a substantial investment in bringing down the cost of manufacturing laser diodes for pumping the Nd:glass laser medium. This needs to begin as soon as possible since it will have a considerable impact on the near term cost of the prototype laser system. A prototype laser beamline will require ~200 MW of pump-diode power. At the present >\$1/Watt cost of laser diodes, a single LIFE Laser beamline would need over \$200M worth of diodes alone, which could be prohibitive. On the other hand, if the cost of diodes could be brought down to \$0.1/Watt in the near term, the construction of a prototype beamline may become affordable. The diode production learning curve in Figure 7 suggests that this expectation for diode costs is reasonable at the scale of manufacturing required for such a prototype.

Design of a LIFE Pilot Plant would follow testing of the prototype beamline and development of the crucial

target and LIFE engine technologies. Sufficient manufacturing capacity for the laser optics (glass, fused quartz, and DKDP crystals) would need to be developed earlier to meet the construction schedule. Additionally, diode production costs would have to come down much more than for the prototype beamline, since some 20 GW of diodes will be needed for the Pilot Plant. We envision that down-selection of the method, and facilitization of the laser diode manufacturing capacity, will proceed in parallel with development of the optics manufacturing capacity.

XI. CONCLUSION

Preliminary conceptual system designs for the LIFE Laser driver were developed. Our approach heavily leverages our experience in high-energy Nd:glass laser technology developed for the National Ignition Facility (NIF),¹ along with high-energy-class diode-pumped solid-state laser (HEC-DPSSL) technology developed for LLNL's Mercury laser system.²

Different versions of the laser system design are suitable for indirect-drive, hot spot ignition or indirect-drive, fast ignition targets. Main amplifiers for both approaches use laser-diode-pumped Nd:glass slabs oriented at Brewster's angle, as in NIF, but the slabs are much thinner to allow for cooling by high velocity helium-gas as in the Mercury laser system.² The designs also use He-gas-cooled, highly deuterated thin crystals of DKDP for Pockels cell switches, and frequency conversion. Mass-production of pump-diode lasers is needed to bring their cost down to the order of \$0.01 per Watt of peak output power to make the LIFE application economically attractive. Engineering studies performed at LLNL, and by diode manufacturers indicate that the required laser diode cost reduction is achievable.

ACKNOWLEDGEMENTS

This work was performed under the auspices of the U.S. Department of Energy by Lawrence Livermore National Laboratory under contract DE-AC52-07NA27344.

REFERENCES

1. E. I. MOSES, "The National Ignition Facility (NIF): A Path to Fusion Energy," *Energy Conversion and Management* **49**, 1795-1802 (2008).
2. A. BAYRAMIAN et al., "The Mercury project: A high average power, gas-cooled laser for inertial fusion energy development," *Fusion Science and Technology*, **52**, 383 (2007).
3. J. D. LINDL et al., "The physics basis for ignition using indirect-drive targets on the National Ignition Facility," *Physics of Plasmas* **11**, 339 (2004).
4. M. TABAK et al., "Ignition and high gain with ultrapowerful lasers," *Physics of Plasmas* **1**, 1626 (1994).
5. S. SKUPSKY et al., "Improved laser beam uniformity using the angular dispersion of frequency-modulated light," *J. Appl. Phys.* **66**, 3456 (1989).
6. C. ORTH et al., "A Diode-Pumped Solid State Laser Driver for Inertial Fusion Energy," *Nuclear Fusion* **36**, 75 (1996).
7. C. A. HAYNAM et al., "National Ignition Facility Laser Performance Status," *Appl. Opt.* **46**, 3276 (2007).
8. J. T. HUNT et al., "Suppression of self-focusing through low-pass spatial filtering and relay imaging," *Appl. Opt.* **17**, 2053 (1978).
9. J. E. MURRAY et al., "Spatial filter pinhole development for the National Ignition Facility," *Appl. Opt.* **39**, 1405 (2000).
10. B. M. VAN WONTERGHEM et al., "Performance of a prototype for a large-aperture multipass Nd:glass laser for inertial confinement fusion," *Appl. Opt.* **36**, 4932 (1997).
11. D. EIMERL "Thermal Aspects of High Average Power Electro-optic Switches" *IEEE J. Quant. Electron.* **QE-23** 2238-2251 (1987).
12. C. A. EBBERS, J. HAPPE, N. NIELSEN, S. P. VELSKO, "Optical absorption at 1.06 μm in highly deuterated potassium dihydrogen phosphate" *Appl. Opt.* **31** 1960-1964 (1992)
13. D. EIMERL "High Average Power Harmonic Generation" *IEEE J. Quantum Electronics*, **QE-23** 575-592 (1987)
14. H. T. POWELL et al., "Flashlamp Pumping of Nd:Glass Disk Amplifiers," *SPIE Proceedings* 1277, 103 (1990).
15. P. CRUMP et al., ">360 W and >70% Efficient GaAs-Based Diode Lasers," *SPIE Proceedings* 5711, 21-29 (2005).

16. H. LI et al., "Near 1 kW of Continuous-Wave Power From a Single High-Efficiency Diode-Laser Bar," *IEEE Photonics Technology Letters* **19**, 960-962 (2007).
17. C. M. STICKLEY et al., "Overview of Progress in Super High Efficiency Diodes for Pumping High Energy Lasers," *SPIE Proceedings* 6401, 610405-1 (2006).
18. J. H. CAMPBELL, T. I. SURATWALA, C. B. THORSNESS, J. S. HAYDEN, A. J. THORNE, J. M. CIMINO, A. J. MARKER III, K. TAKEUCHI, M. SMOLLEY, and G. F. FICINI-DORN, "Continuous melting of phosphate laser glasses", *J. Non-Crystalline Solids*, **263 & 264**, 342 (2000).
19. J. A. MENAPACE, P. J. DAVIS, W. A. STEELE, L. L. WONG, T. I. SURATWALA, and P. E. MILLER, "MRF Applications: measurement of process-dependent subsurface damage in optical materials using MRF wedge techniques," Boulder Damage Symposium XXXVII, Annual Symposium on Optical Materials for High Power Lasers, Boulder, Colorado, *SPIE Proceedings*, 5991, 599103 1-11 (2005).
20. A. K. BURNHAM, L. HACKEL, P. WEGNER, L. HRUBESH, B. PENETRANTE, P. WHITMAN, S. DEMOS, J. MENAPACE, M. RUNKEL, M. FLUSS, M. FEIT, M. KEY, and T. BIESADA, "Improving 351-nm damage performance of large-aperture fused silica and DKDP optics," *SPIE Proceedings* 4679, 173-185 (2002).
21. T. SURATWALA, R. STEELE, M.D. FEIT, L. WONG, P. MILLER, J. MENAPACE, and P. DAVIS, "Effect of rogue particles on the sub-surface damage of fused silica during grinding/polishing," *J. Non-Crystalline Solids* **354**, 2023 (2008)
22. M. RUNKEL, K. NEEB, M. STAGGS, J. AUERBACH, and A.K. BURNHAM, "The results of raster-scan laser conditioning studies on DKDP triplers using Nd:YAG and excimer lasers," *SPIE Proceedings* 4679, 368-383 (2002).
23. J. A. MENAPACE, B. PENETRANTE, D. GOLINI, A. SLOMBA, P. E. MILLER, T. PARHAM, M. NICHOLS, and J. PETERSON, "Combined advanced finishing and UV-laser conditioning for producing UV-damage-resistant fused silica optics," *SPIE Proceedings* 4679, 56-67 (2002).
24. I. L. Bass, V. G. Draggoo, G. M. Guss, R. P. Hackel, and M. A. Norton, "Mitigation of laser damage growth in fused silica NIF optics with a galvanometer scanned CO₂ laser," *SPIE Proceedings* 6261, 62612A1-62612A10.
25. C. J. STOLZ, J. ADAMS, M. D. SHIRK, M. A. NORTON, and T. L. WEILAND, "Engineering meter-scale laser resistant coatings for the near IR," *SPIE Proceedings* 5963, 59630Y1-59630Y9.
26. M. D. FEIT, A. M. RUBENCHIK, M. R. KOZLOWSKI, F. Y. GENIN, S. SCHWARTZ, and L.M. SHEEHAN, "Extrapolation of damage test data to predict performance of large-area NIF optics at 355 nm," *SPIE Proceedings* 3578, 226-233 (1999).
27. A. E. CHMEL, "Fatigue laser-induced damage in transparent materials," *Mat.Sci.&Eng.* **49**, 175 (1997).
28. J. F. LATOWSKI, A. KUBOTA, M. J. CATURLA, S. N. DIXIT, J. A. SPETH, and S. A. PAYNE, "Fused Silica Final Optics For Inertial Fusion Energy: Radiation Studies And System-Level Analysis," *Fus.Sci.Tech.* **43**, 540 (2003).
29. R. S. AFZAL, A. W. YU, J. L. DALLAS, A. MELAK, A. T. LUKEMIRE, L. Ramos-Izquierdo, and W. MARMAKOS, "The Geoscience Laser Altimeter System (GLAS) Laser Transmitter," *IEEE J.Slct.Tpcs.Quant.Elec.* **13**, 1077 (2007).