

# THE DESIGN OF POWER DC BUS SYSTEM TO INCREASE THE SOLAR EFFICIENCY BY USING DC-DC CONVERTER

<sup>1</sup>Miss. Bhagyashree N. Pikalmunde, <sup>2</sup>Mr. Vinod Bhongade

<sup>1</sup> Dept. of Electrical Engineering, Gondwana University, R.C.E.R.T, Chandrapur, Maharashtra, (India)

<sup>2</sup>Associate Professor, Department of Electrical Engineering, R.C.E.R.T, Chandrapur, Maharashtra, (India)

## ABSTRACT

Non conventional energy based on photovoltaic system with storage energy battery is necessary to load requirement for supply to electric grid. Due to use of dc-ac convertor, the efficiency does not improve. The power conditioning is done by a dc-dc converter and a dc-ac inverter stages to produce the desired ac source. This is also done even when the load is of dc type, such as typical portable electronic devices that require ac adaptors to be powered from the ac mains. The aim of this project is to propose a hybrid PV-battery-powered dc bus system, that eliminates the dc-ac conversion stage, resulting in lower cost and improved overall energy conversion efficiency. A high-gain hybrid boost fly back converter is introduced with higher voltage conversion ratio than conventional boost convertor topology.

**Keywords:** DC Bus System, Dc-Dc Converter, Hybrid Fly Back Boost Converter, Solar Cell, PV Power System.

## I. INTRODUCTION

Recently, we know that due to population growth, Industrialization, and Increasing leaving of standard the electricity demand is sharply increase. To fulfill these demand conventional sources of energy contributes around 80% demand. The conventional sources are coal, petroleum, natural gas etc .As this sources are non renewable there is fear that they will get exhausted eventually in the next century .so ,predicting the future demand and future scenario of energy ,it is mandatory to promote the renewable sources of energy ,as these sources has much potential. Solar energy is the most readily available and free source of energy, since prehistorically times. It is estimated that solar energy equivalent to over 15000 times the world annual commercial energy consumption reaches the earth every year. Solar energy stored in the form of dc. This dc energy is converted into ac as per our load requirement. But in ac fluctuation is more that results in poor efficiency and voltage instability. To avoid and get maximum output, we concentrate in this paper mainly on dc to dc convertor. However, when a renewable energy source such as solar power is available

and since it is dc in nature. For that PV panel is required. The PV panel varying wattages available from a few watts to several hundred watts per panel. A DC load center for hooking up the batteries, and charge controller, and PV panels. Note that AC is not handled by your DC load center.

### 1.1. Buck Converters (DC-DC) structure

A buck converter (dc-dc) is shown in Fig. Only a switch is shown, for which a device as described earlier belonging to transistor family is used. Also a diode (termed as freewheeling) is used to allow the load current to flow through it, when the switch (i.e., a device) is turned off. The load is inductive (R-L) one. In some cases, a battery (or back emf) is connected in series with the load (inductive). Due to the load inductance, the load current must allowed path, which provided by diode. Otherwise, in absence of above diode, the high induced emf of the inductance, as load current tends to decrease, it may cause damage to switching device. If switching device used is thyristor, this circuit is called as a step-down chopper, as output voltage is normally lower than the input voltage. Similarly, this dc-dc converter is termed as buck one, due to reason given later one, due to reason given later.

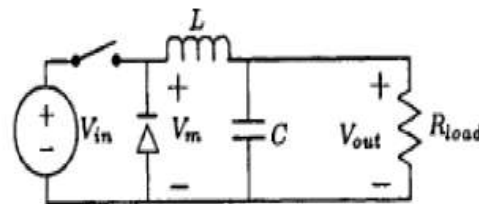

Fig .1: Buck Converters (DC-DC)

## II. AN OVERVIEW OF PROPOSED WORK

A new approach to power generation using solar structure and DC-DC converter is presented. And which has higher efficiency and lower cost in compare to other methods of AC power generation. Initially, we investigate the effect of voltage on the efficiency of the system. And also calculate to the overall efficiency of the system.

In this project, both hardware and software setups are used. The hardware setup consists of PV panel, DC-DC converter, comparator, DC Bus, microcontroller, relay. With the help of hardware setup observe the output voltage and also observation of efficiency.

In the software setup, MATLAB software is used to understand the graphical nature of temperature by simulation. For that Embedded C programming is prefer to use.

The following steps to make a module:

1. The hardware and software setup are used.
2. Hardware setup consists of different components.
3. Observe the compares of voltage

4. Observe efficiency of the system.

### III. HARDWARE REQUIREMENT

- DC-DC Converter
- Microcontroller IC 89c51
- Comparator
- PV panel with Battery
- Relay
- Digital Multi-meter

#### 3.1. DC-DC Converter

DC-DC Converter is an electronic circuit which converts a source of direct current (DC) from one voltage level to another. DC to DC converters are important in portable electronic devices such as cellular phones, laptops computers, which are supplied with power from batteries primarily. Such electronic devices often contain several sub-circuits, each with its own voltage level requirement different from that supplied by the battery or an external supply (sometimes higher or lower than the supply voltage). Additionally, the battery voltage declines as its stored power is drained. Switched DC-DC converters offer a method to increase voltage from a partially lowered battery voltage thereby saving space instead of using multiple batteries to accomplish the same thing. Most DC-DC converters also regulate the output voltage. Some exceptions include high-efficiency LED power sources. In that paper the DC-DC Converter supply electricity to the battery with is connected to the relay as well as Auxiliary supply. As shown in the fig.

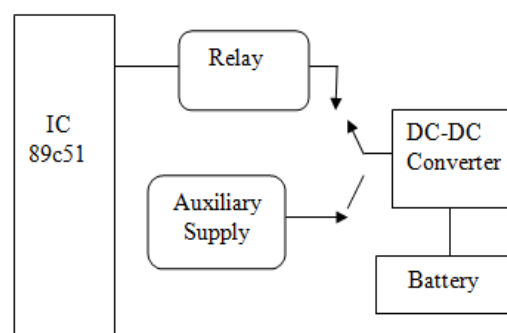
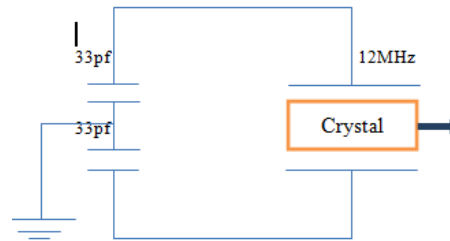

**Fig. 2: Basic Structure of the System**

#### 3.2. Microcontroller IC 89C51

The microcontroller IC 89c51 receive signal from Amplifier LM324 in the form of one (1) at a set limit of 6volt dc from solar panel through LM324.If the panel generates t low signal than 6 volts then this LM324 gives zero(0)

signal to the microcontroller IC 89c51. The IC also used to control the relay device for switching purpose. It consists of crystal oscillator device this device to generate the trigger signals of 12MHz.



**Fig.3: Cristal Oscillater**

### 3.3. Comparator

In this paper, two comparator amplifier IC LM324 is used .The comparator amplifier IC LM324 which finally goes to battery and the second amplifier IC LM324 gives signal from auxiliary supply to the battery .This two comparator compares' the signals from solar and auxiliary supply and gives the output.

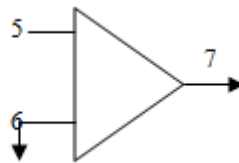

**Fig. 4: LM 324**

### 3.4. PV panel with Battery

The Solar energy is the most readily available and free source of energy, since prehistorically times. Solar energy stored in the form of dc. This dc energy is converted into ac as per our load requirement. The solar panel receiving the sun rays and which generate 6volts dc which signals to provide amplifier. These amplifiers IC LM324 send the signal to the microcontroller.

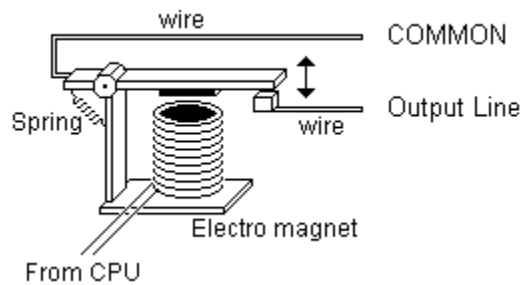

**Fig. 5: Solar Panel**

The solar energy is used to generate the electrical signal and this electrical energy stored in the battery”.

### 3.5. Relay

The Relay is used to reverse the supply to change the mode i.e. to switch form DC supply to the auxiliary supply. It is used for Domestic Appliances, Office Machines, Audio Equipment, Coffee-Pots, Control units, etc. Hear the relay is used to the purpose of activation of the switch. In this project the relay is used to control of the DC signals.



**Fig. 6: Relay Circuit Diagram**

### 3.6. Digital Multimeter

The digital millimeter reads the output from the battery .here the use of millimeter for to read the value of two signals one is from solar system and another is from auxiliary supply and compares both values with the help of tow comparator amplifiers IC LM324 and display the beneficial value of the system.

## IV. WORKING OF THE MODEL

From block diagram it consists of different types of blocks like solar panel, comparators, microcontroller IC 89c51, relay, rectifier, DC-DC converter, battery. Firstly the solar panel receives sunlight to convert into electricity and these energy fed to the first comparator amplifier LM324.the comparator fed the signal to microcontroller IC 89c51.the IC69c51 take signal from comparator amplifier and fed to the relay device in the form of 1 signal at a constant voltage 6v.During the operation relay connected to the DC-DC converter with battery & the load gives the constant energy from battery device.

If the solar panel generates the less energy than 6v dc the first comparator fed the signal to microcontroller IC89c51 in the form 0 signal. Then that time relay will switch from DC-DC converter at the same auxiliary supply is connected to the DC-Dc converter and this device stored the energy in the battery, finally this result compare through two comparator amplifier with the help of digital multi-meter.

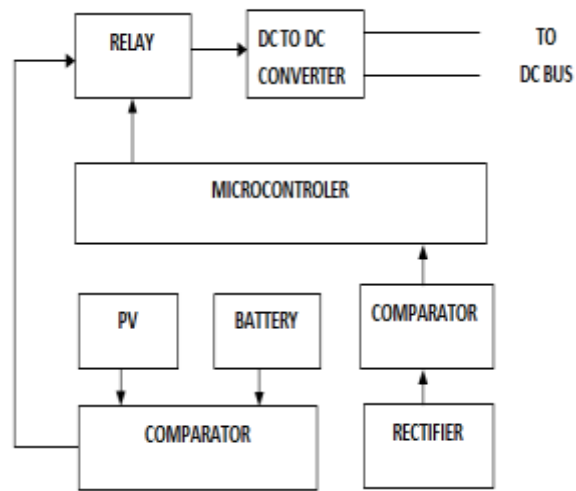

Fig .7: Block Diagram

**V. COMPARISM RESULT**

IRRADIANCE	CURRENT	VOLTAGE
1000	1	16
800	1	14
600	0.5	10

Fig. 8: Table

**VI. SIMULATION RESULTS**

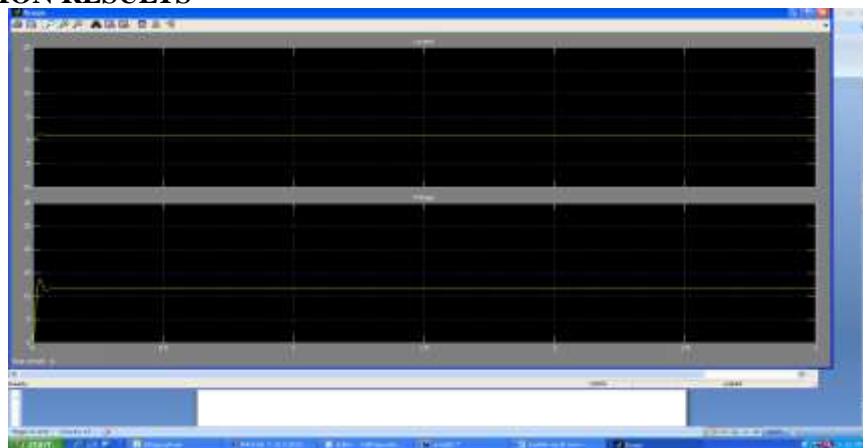
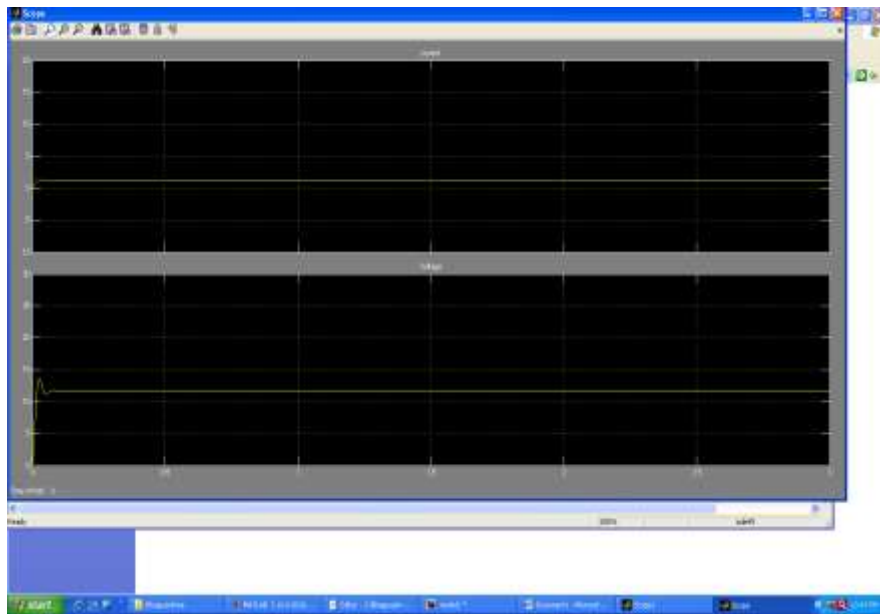

Fig.9: Due to high irradiance voltage increases

(Irradiance = 1000, Voltage = 16v, Current =1amp)



**Fig.10: Due to high irradiance voltage decreases**

(Irradiance = 800, Voltage = 14v, Current =1amp)

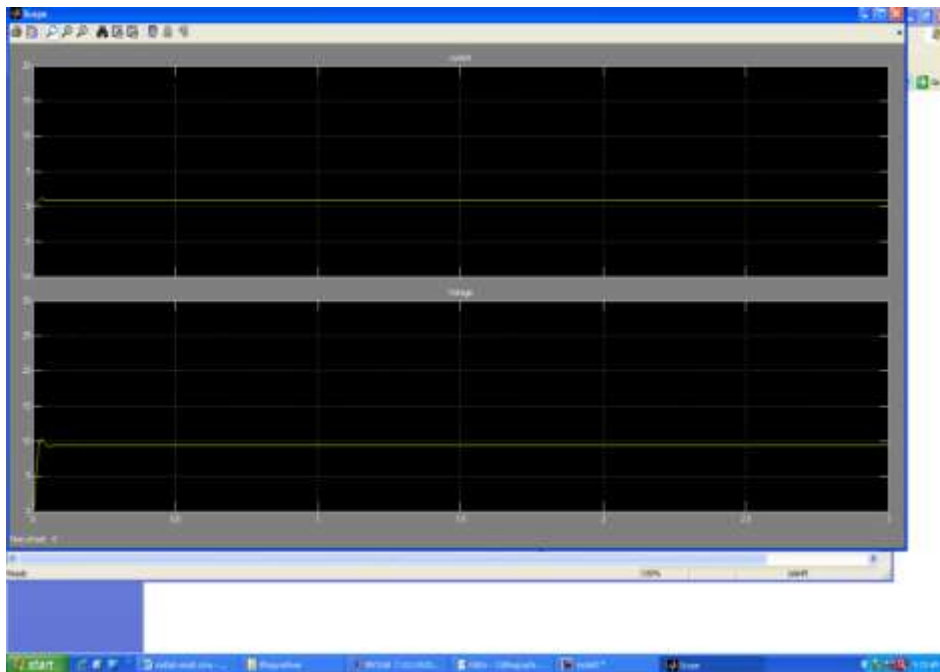

**Fig.11: Due to high irradiance voltage decreases**

(Irradiance =600, Voltage = 10v, Current =0.5amp)

## VII. RESULT

From hardware result and mat lab simulation result we observed that the due to used of DC-DC converter and a hybrid PV-battery-powered dc bus system, that eliminates the dc–ac conversion stage, resulting in lower cost and improved overall energy conversion efficiency.

## VIII. CONCLUSION

We conclude that, when the load is of dc type, such as typical portable electronic devices that require ac adaptors to be powered from the ac mains. The aim of project is to propose a hybrid PV-battery-powered dc bus system that eliminates the dc–ac conversion stage, resulting in lower cost, improved overall energy conversion efficiency. A high-gain hybrid boost–fly back converter is, also introduced with several times higher voltage in higher dc bus levels and lower cable conduction losses.

## REFERENCES

- [1]. S.Y. Tsen, J. S. Kuo, S. W. Wang, and C. T. Hsieh, “Buck–boost combined with active clamp fly back converter for PV power system,” in Proc. IEEE Power Electron. Spec. Conf., 2007, pp. 138–144.
- [2]. Dylan Dah-Chuan Lu, Member, IEEE, and Vassilios G. Agelidis, Senior Member, IEEE. “Photovoltaic-Battery-Powered DC Bus System for Common Portable Electronic Devices”.
- [3]. L. Huber and M. M. Jovanovic, “A design approach for server power supplies for networking,” in Proc. IEEE-APEC’00 Conf., 2000, pp.1163–1169.
- [4]. Battery Council International. Battery recycling [Online].  
Available:<http://www.batterycouncil.org/LeadAcidBatteries/BatteryRecycling/tabid/71/Default.aspx>
- [5]. F. Blaabjerg, Z. Chen, and S. B. Kjaer, “Power electronics as efficient interface in dispersed power generation systems,” IEEE Trans. Power Electron., vol. 19, no. 5, pp. 1184–1194, Sep. 2004.
- [6]. S. B. Kjaer, J. K. Pedersen, and F. Blaabjerg, “A review of single-phase grid-connected inverters for photovoltaic modules,” IEEE Trans. Ind. Appl., vol. 41, no. 5, pp. 1292–1306, Sep./Oct. 2005.
- [7]. F. Blaabjerg, R. Teodorescu, M. Liserre, and A. V. Timbus, “Overview of control and grid synchronization for distributed power generation systems,” IEEE Trans. Ind. Electron., vol. 53, no. 5, pp. 1398–1409, Oct.2006.
- [8]. J. Knight, S. Shirsavar, and W. Holderbaum, “An improved reliability Cuk based solar inverter with sliding mode control,” IEEE Trans. Power Electron., vol. 21, no. 4, pp. 1107–1115, Jul. 2006.
- [9]. Q. Li and P. Wolfs, “A current fed two-inductor boost converter with an integrated magnetic structure and passive lossless snubbers for photovoltaic module integrated converter applications,” IEEE Trans. Power Electron., vol. 22, no. 1, pp. 309–321, Jan. 2007.



- [10]. R. J. Wai, W. H. Wang, and C. Y. Lin, "High-performance stand-alone photovoltaic generation system," *IEEE Trans. Ind. Electron.*, vol. 5, no. 1, pp. 240–250, Jan. 2008.
- [11]. S.Y.Tseng, J. S.Kuo, S.W.Wang, and C.T.Hsieh, "Buck–boost combined with active clamp flyback converter for PV power system," in *Proc. IEEE Power Electron. Spec. Conf.*, 2007, pp. 138–144.
- [12]. Y. M. Chen and Y. C. Liu, "Development of multi-port converters for hybrid wind-photovoltaic power system," in *Proc. IEEE Region 10 Int. Conf. (TENCON)*, 2001, pp. 804–808.
- [13]. Y.M. Chen, Y. C. Liu, F. Y.Wu, and Y. E.Wu, "Multi-input converter with power factor correction and maximum power point tracking features," in *Proc. IEEE Appl. Power Electron. Conf.*, 2002, pp. 490–496.
- [14]. K. Kobayashi, H. Matsuo, and Y. Sekine, "An excellent operating point tracker of the solar-cell power supply system," *IEEE Trans. Ind. Electron.*, vol. 53, no. 2, pp. 495–499, Apr. 2006.
- [15]. K. P. Yalamanchili and M. Ferdowsi, "Review of multiple input dc–dc converters for electric and hybrid vehicles," in *Proc. IEEE Veh. Power Propulsion Conf.*, 2005, pp. 552–559.
- [16]. Y. M. Chen, Y. C. Liu, S. C. Hung, and C. S. Cheng, "Multi-input inverter for grid-connected hybrid PV/wind power system," *IEEE Trans. Power Electron.*, vol. 22, no. 3, pp. 1070–1077, May 2007.
- [17]. T. F. Wu, C. H. Chang, and Y. J. Wu, "Single-stage converters for PV lighting systems with MPPT and energy backup," *IEEE Trans. Aerosp. Electron. Syst.*, vol. 35, no. 4, pp. 1306–1317, Oct. 1999.
- [18]. Q. Zhao and F. C. Lee, "High-efficiency, high step-up dc–dc converters," *IEEE Trans. Power Electron.* vol. 18, no. 1, pp. 65–73, Jan. 2003.
- [19]. K. C. Tseng and T. J. Liang, "Novel high-efficiency step-up converter," *Proc. Inst. Electr. Eng. (IEE) Electr. Power Appl.*, vol. 151, pp. 182–190, 2004.
- [20]. R. J. Wai and R. Y. Duan, "High step-up converter with coupled inductor," *IEEE Trans. Ind. Electron.*, vol. 20, no. 5, pp. 1025–1035, Sep. 2005.