

DESIGN OF MULTILoop CONTROLLER FOR THREE TANK PROCESS USING CDM TECHNIQUES

N. Kanagasabai¹ and N. Jaya²

^{1,2}Department of Instrumentation Engineering, Annamalai University,
Annamalainagar, 608002, India

ABSTRACT

In this study the controller for three tank multi loop system is designed using coefficient Diagram method. Coefficient Diagram Method is one of the polynomial methods in control design. The controller designed by using CDM technique is based on the coefficients of the characteristics polynomial of the closed loop system according to the convenient performance such as equivalent time constant, stability indices and stability limit. Controller is designed for the three tank process by using CDM Techniques; the simulation results show that the proposed control strategies have good set point tracking and better response capability.

KEYWORDS

Coefficient diagram method, three tank, multiloop, CDM-PI

1. INTRODUCTION

Most of the processes industry in power plants, refinery process, aircrafts and chemical industries are multivariable or multi-input multi-output (MIMO) and control of these MIMO processes are more complicated than SISO processes. The strategies are used to design a controller for the Single input and single output (SISO) process cannot be applied for Multi input and multi output (MIMO) process because of the more interaction between the two loops. The different methods have been presented in the literature for control [1] of MIMO process. Proportional-integral-derivative (PID) or Proportional-Integral (PI) based controllers are used very commonly to control three tank systems. Generalized synthesis method used to tuning the controller parameters. Generally the two types of control schemes are available to control the MIMO processes. The first control scheme or multiloop control scheme, where single loop controller are used to in the form of diagonal matrix is one.. The second scheme is a [3] multivariable controller known as the centralized controller. Matrix is not a diagonal one.

In this paper, the Coefficient Diagram Method (CDM) can be used to design a controller for MIMO process. Now the CDM is well established approach to design a controller, which provides an outstanding time domain characteristics of closed loop systems. Basically the CDM is based on pole assignment, which can locate of the closed-loop system are used to obtained the predetermined values. Although it has been used to demonstrate the design based on CDM. It has some robustness and is possible to see that of the smooth response without oscillation in change in the model of the process exists.

2. COEFFICIENT DIAGRAM METHOD

The CDM design procedure is quiet easily understandable, efficient and useful. Therefore, the coefficients of the CDM controller polynomials which can be determined more easily than the PID

controller strategies. The CDM design procedure efficient design method (CDM) is possible to design very good controllers with less effort and easy when compared with the other method, under the conditions of stability, time domain performance and robustness. The transfer function of the numerator and denominator of the system are obtained independently according to stability and response requirements.. Generally the order of the controller designed by CDM is lower than the order of the plant. when using the PI controller for the first order plant, the order of the controller is equal to the order of the plant, and for the second order plant, the order of the controller is lower than the order of the plant equal to one .The parameters are stability index γ_i equivalent time constant τ_i and stability limit γ_i^* which represent the desired performance. The basic block diagram of the CDM design for a single-input-single-output system is shown in Fig. 1. Where y is the output signal, r is the reference signal, u is the controller signal and d is the external disturbance signal. N(s) and D(s) are to be numerator and Denominator of the plant transfer function. A(s) is the denominator polynomial of the controller transfer function, F(s) and B(s) are called the reference numerator and the feedback numerator polynomials of the controller transfer function. The CDM controller structure they are similar to each other. It has Two Degree of Freedom (2DOF) control structure because of two numerators in controller transfer function. The system output is given by

$$y(s) = \frac{N(s)F(s)}{P(s)} r + \frac{A(s)N(s)}{P(s)} d \quad (1)$$

$$P(s) = A(s) D(s) + B(s) N(s) = \sum_{i=0}^n a_i s^i \quad (2)$$

Where P(s) is the characteristics polynomial of the closed loop system. The CDM design parameters with respect to the characteristic polynomial coefficient which are equivalent time constant τ_i , stability index γ_i and stability limit γ_i^* are defined as

$$\tau_i = \frac{a_1}{a_0} \quad (3a)$$

$$\gamma_i = \frac{a_i^2}{a_{i+1} a_{i-1}}, i=1 \sim (n-1), \quad \gamma_0 = n \quad (3b)$$

$$\gamma_i^* = \frac{1}{\gamma_i - 1} + \frac{1}{\gamma_i + 1} \quad (3c)$$

From equation (3a - 3c), the coefficients a_i and the target characteristic polynomial $P_{target}(s)$ is given by

$$a_i = \frac{\tau_i^i}{\prod_{j=1}^{i-1} \gamma_j} a_0 = Z_i a_0 \quad (4)$$

$$P_{target}(s) = a_0 \left[\left\{ \sum_{i=2}^n \left(\prod_{j=1}^{i-1} \frac{1}{\gamma_j} \right) \binom{i}{i-j} (s)^i \right\} + s + 1 \right] \quad (5)$$

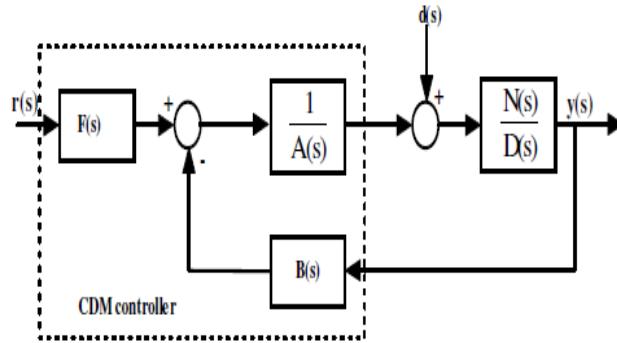

Fig.1: Basic block diagram of CDM

3 .CONTROLLER DESIGN USING CDM

Many of the processes in industry are described as First order process with time delay (FOPTD)

$$G_p(s) = \frac{K_p}{p\tau + 1} e^{-s\theta} \quad (6)$$

Where k_p is process gain τ is time constant and θ is time delay. Since the transfer function of the process is of two polynomials, one is numerator polynomial $N(s)$ of degree m and other is the denominator polynomial $D(s)$ of degree n where $m < n$, the CDM controller polynomial $A(s)$ and $B(s)$ of structure shown in Fig 1 are represented by

$$A(s) = \sum_{i=0}^p l_i s^i \text{ and } B(s) = \sum_{i=0}^q k_i s^i \quad (7)$$

The controller to be realized for the condition $p > q$ must be satisfied. For a better performance the degree of controller polynomial chosen is important. The controller polynomial for FOPTD process with numerator Taylor's approximation is chosen as

$$A(s) = s \quad (8a)$$

$$B(s) = k_1 s + k_0 \quad (8b)$$

The determination of the coefficient of the controller polynomial in CDM pole-placement method is used. The feedback controller is chosen by pole-placement technique then a feed forward controller is determined so as to match the closed loop system steady-state gain . Hence, a polynomial depending on the parameters k_i and l_i is obtained. Then, a target characteristic polynomial $P_{target}(s)$ is obtained by placing the design parameters into Eqn 5. Equating these two polynomials is obtained, which is known to be Diophantine equation.

$$A(s) D(s) + B(s) N(s) = P_{target}(s) \quad (9)$$

Solve these equations the controller coefficient for polynomial $A(s)$ and $B(s)$ is found .The numerator polynomial $F(s)$ which is defined as pre-filter is chosen to be

$$F(s) = P(s)/N(s) |_{s=0} = P(0)/N(0) \quad (10)$$

This way, the value of the error that may occur in the steady-state response of the closed loop system is reduced to zero. Thus, F(s) is computed by

$$F(s) = P(s)/N(s) \Big|_{s=0} = 1/k_p \quad (11)$$

4. CDM-PI CONTROLLER

The transfer function model of conventional PI controller is

$$G_c(s) = k_c \left(1 + \frac{1}{T_i s}\right) \quad (12)$$

The controller gain k_c and integral time T_i are relevant with polynomial coefficient as $k_1=k_c$ and $k_0=k_c/T_i$. By applying the CDM, the values of k_1 and K_0 can be calculated as follows:

- 1) To find the equivalent time constant τ
- 2) The stability index $\gamma_1 = 3$, $\gamma_2 = 4.5$ are used.
- 3) From the Eqn.(2), derive the characteristic polynomial with the PI controller stated in Eqn (12) and equates to the characteristic polynomial obtained from Eqn(14). Then the parameters k_1 and K_0 of the PI controller are obtained.
- 4) Chose the pre-filter $B(s) = K_0$ and $G_f(s)$ is feed forward controller

$$G_f(s) = \frac{F(s)}{B(s)} = \frac{k_0}{k_1 s + 1} = \frac{1}{T_i s + 1} \quad (13)$$

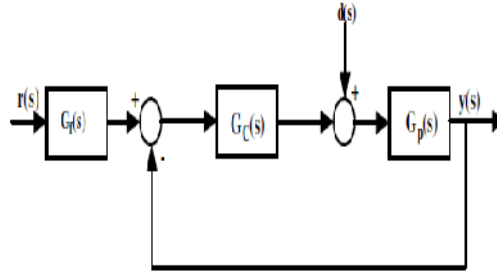

Fig.2: Equivalent block diagram of CDM

5. THREE TANK PROCESS

The three-tank process taken for study [6] is shown in Fig 2. The controlled variables are the level of the tank1 (h_1) and level of the tank3 (h_3) and Manipulated variables are in flow of tank1 (fin_1) and in flow of tank3 (fin_3). The steady state operating data of the Three-tank system is given in Table1. The material balance equation for the above three-tank system is given by

$$\frac{dh_1}{dt} = \frac{fin_1}{s_1} - \frac{Az_1}{s_1} \sqrt{2g(h_1 - h_2)} \quad (14)$$

$$\frac{dh_2}{dt} = \frac{AZ_1}{s_2} \sqrt{2g(h_1 + h_2)} - \frac{AZ_3}{s_2} \sqrt{2g(h_2 - h_3)} \quad (15)$$

$$\frac{dh_3}{dt} = \frac{fin_3}{s_3} + \frac{Az_3}{s_3} \sqrt{2g(h_2 - h_3)} + \frac{Az_2}{s_3} \sqrt{2gh_3} \quad (16)$$

Table.1 Steady state operating parameters of three tank process

h1, h2, h3 in m	0.7,0.5,0.3
fin1 and fin3 in ml/sec	100
Outflow coefficient (Az1, Az2, Az3)	2.251e-5,3.057e-5,2.307e-5
Area of tank (S1-S3)in m ²	0.0154
Acceleration due to gravity in m/sec ²	9.81

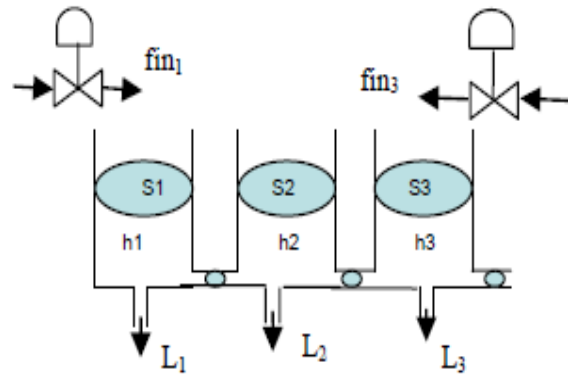

Fig.3: Schematic diagram of three tank process

6. SIMULATION RESULTS AND DISCUSSION

In this work, the coefficient diagram method based control system is considered for the three tank system under nominal operating conditions. The main objective of this process is to control the level of Tank1 and Tank3. The coefficient diagram method is designed based on the thorough knowledge of the three tank process. Also the PI controller parameters for the interacting three tank process are obtained by utilizing direct synthesis method. The controller parameters of three tank system are obtained by using direct synthesis method for the closed loop system. The controller settings for loop1 $Kc_1=1.24137$, $Ti_1=1336.5$ and for loop2 $Kc_2=1.4589$, $Ti_2=1315.5$. The multi loop CDMPI controller is obtained with time constant $\tau=10$ and found to be $Kc_1=2.1720$, $Ti_1=0.111$ and $\tau_{timeconstant} =15$ $Kc_2=4.1284$ $Ti_2=0.1113$ for loop 1 and loop2 respectively. The open loop response of the process is shown in Fig.4. The closed loop response of the three tank process for a set point change in tank1 from its operating value of 0.7m to 1m is shown in Fig.5 and its corresponding effect of interaction in tank3. Fig. 6 shows the closed loop response of tank3 for a set point change of 0.3 m to 1.0 from its operating value and its corresponding effect of interaction in tank1 and their values are tabulated in Table 2. With same operating conditions, a simulations runs are carried out for direct synthesis based three tank processes for comparative study. The simulated servo responses are stored in Fig .7 and Fig 8. The performance indices are calculated in terms of settling time, Integral Square Error (ISE) and Integral Absolute Error (IAE) and values are

charted in Table 2. From the table it is observed that intelligent fuzzy control system gives satisfactory performance than the PI controller. The servo and regulatory responses are plotted in Fig .9 to 12.The servo tracking and regulatory responses are plotted in Fig. 13 to 16. The performances of these controllers are evaluated and tabulated in Table 6. From the table, it is clearly indicates that the control augmented the control system is considerably reduced the effect of load disturbance in the process variable compared to the PI controller.

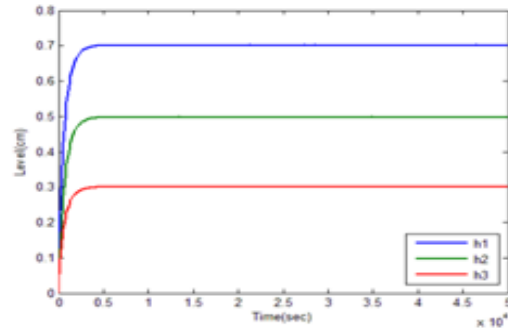

Fig 4. Open loop Response of the three tank process

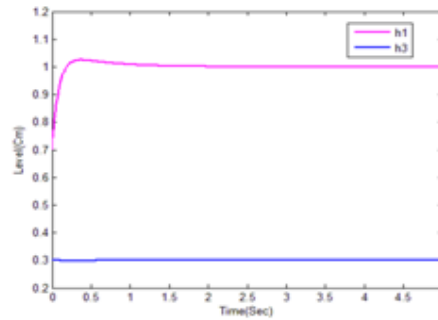

Fig5. Closed loop response of three tank process with set Point change in Tank-1(Conventional PI-Controller)

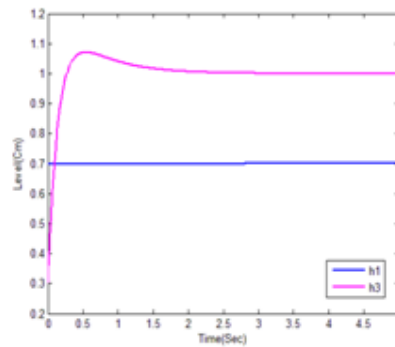

Fig6. Closed loop response of three tank process With set point change in Tank-3(Conventional PI-Controller)

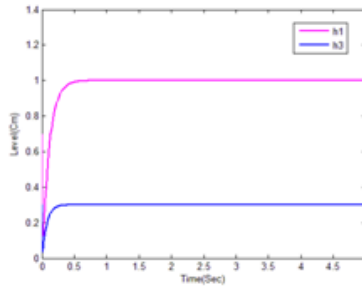

Fig7. Closed loop response of three tank process with set point change in Tank-1(CDM-PI) Controller

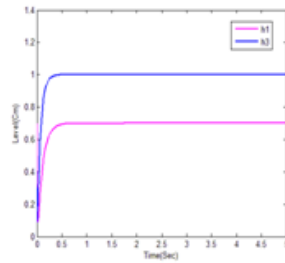

Fig8. Closed loop response of three tank process With set point change in tank-3(CDM-PI) Controller

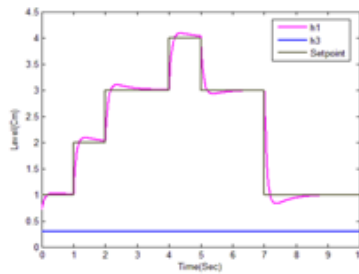

Fig9. Servo tracking response of three tank process in Tank-1(Conventional PI-Controller)

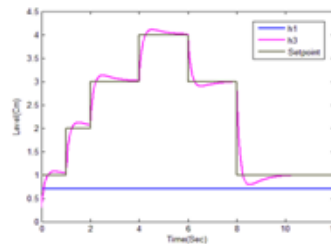

Fig10. Servo tracking response of three tank process in Tank-3(Conventional PI-Controller)

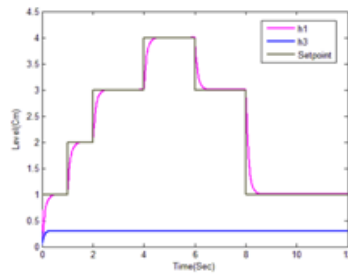

Fig11. Servo tracking response of three tank process in Tank-1(CDM-PI) Controller

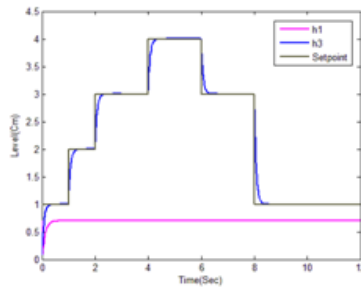

Fig12. Servo tracking response of three tank process in Tank-3(CDM-PI) Controller

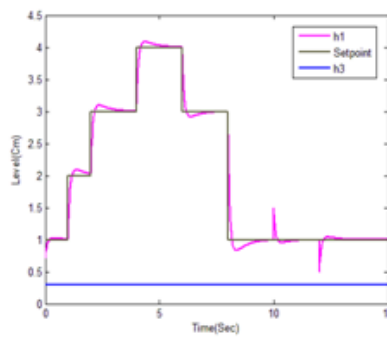

Fig13. Servo tracking and Regulatory response of three tank process in Tank-1 Conventional PI-Controller

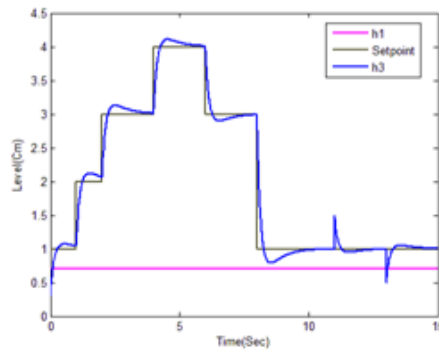

Fig14. Servo tracking and Regulatory response of three tank process in Tank-3 Conventional PI-Controller

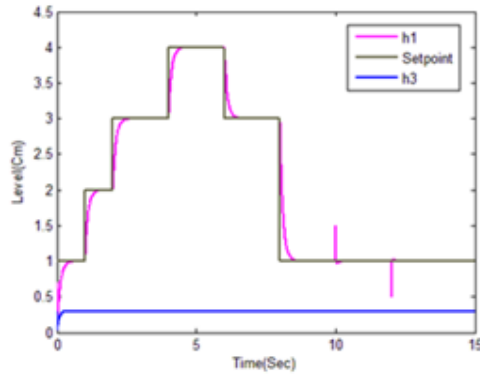

Fig15. Servo tracking and Regulatory response of three tank process in Tank1 (CDM-PI) Controller

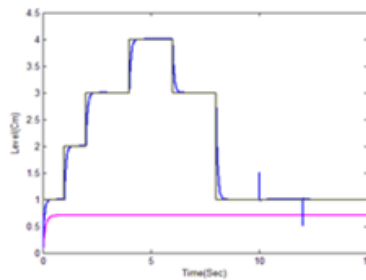

Fig16. Servo tracking and Regulatory response of three tank process in Tank-3(CDM-PI) Controller

Table.2 Performance and evaluation of the controllers

Controller scheme	Controller Parameters					
	LOOP-1			LOOP-2		
	ts	ISE	IAE	ts	ISE	IAE
PI Controller	2.5	0.01813	0.084	3	0.005283	0.0548
	2.25	0.01961	0.108	3.3	0.007632	0.1822
	2.75	0.1454	0.204	3.5	0.18759	0.439
	2.70	1.4576	0.555	3.0	2.466	0.675
CDM-PI Controller	0.9	0.001683	0.009099	0.7	0.0001612	0.0001627
	0.8	0.002002	0.01281	0.65	0.0003276	0.004079
	0.75	0.003767	0.03467	0.8	0.003426	0.004567
	0.95	0.7890	0.05678	0.9	0.98675	0.06326

7. CONCLUSION

In this work the Multiloop CDM-PI controller is designed for three tank process and compared with the conventional –PI controller designed by Synthesis tuning method through simulation. The ts, ISE and IAE are taken as performance indices. The superiority of the CDM-PI control is analyzed and clearly shows that more potential advantages of using CDM-PI control for a three tank process. The control technique has a good set point tracking without any offset with better settling time. The comparison of these above two controllers clearly shows that CDM-PI controller is superior resulting in smoother controller output without oscillations which would like increase the actuator life.

8. REFERENCES

- [1] S.Abraham Lincon., D.Sivakumar., J.Prakash State and Fault Parameter Estimation Applied To Three-Tank Bench Mark Relying On Augmented State Kalman Filter., ICGSTACSE Journal, Volume 7, Issue 1, May 2007.
- [2] M.Zhaung and D.P. Atherton (1994), "PID controller design for TITO system," IEEP process controls Theory Appl., Vol. 141 no.2pp 111-120.
- [3] A. Niderlinski (1971), "A heuristic approach to the design of linear multivariable integrating control system," Automatica, vol.7, 691-701.
- [4] P.J. Cawthrop (1987), "Continuous-Time self-Tuning Control", Vol.1-Design, Research Studies Press, Letchworth, UK.
- [5] Q.G. Wang, B. Zou, T.H. Lee and Q. Bi (1996), "Auto tuning of multivariable PID controllers from decentralized relay feedback," Automatica, vol.33, no.3, pp49-55.
- [6] S. Majhi (2001), "SISO controller for TITO systems", presented at the Int. Can on Energy. Automation and information Tech.
- [7] S.Skogestad, I.Postlethwaite (1996), "Multivariable Feedback Control Analysis and Design," John Wiley & Sons Chichester.
- [8] S.Manabe (1998), "Coefficient Diagram Method," Proceedings of the 14th IFAC Symposium on Automatic Control in Aerospace, Seoul.
- [9] K.Astrom and T. Hagglund (1995), "PID Controllers: Theory Design and Tuning," Instrument Society of America, 2nd Edition.
- [10] I. Kaya (1995), "Auto tuning of a new PI-PD Smith predictor based on time domain specifications," ISA Transactions, vol.42 no.4, pp. 559-575.
- [11] S.Manabe (1994), "A low cost inverted pendulum system for control system education," Proc. of the 3rd IFAC Symp. On advances in control Education, Tokyo.
- [12] A.Desbiens, A. Pomerlau and D. Hodouin (1996), "Frequency based tuning of SISO controller for two –by-two processes," IEE Proc. Control Theory Appl., Vol .143, pp 49-55.
- [13] M.Senthilkumar and S. Abraham Lincon (2012), "Design of stabilizing PI controller for coupled tank MIMO process," International Journal of Engineering Research and Development, Vol.3 no. 10: pp. 47–55.
- [14] S.E Hamamci, I. Kaya and M.Koksal (2001), "Improving performance for a class of processes using coefficient diagram method," presented at the 9th Mediterran conference on control, Dubrovnik.
- [15] S.E. Hamamci (2004), "Simple polynomial controller design by the coefficient diagram method,"WSEAS Trans. on Circuits and Systems, v.3, no.4, pp.951-956.
- [16] S.E. Hamamci and M. Koksal (2003), "Robust controller design for TITO systems with Coefficient Diagram Method s," CCA 2003 IEEE Conference on Control Applications.
- [17] W.L Luyben (1986), "Simple methods for tuning SISO controllers in multivariable systems," Ind. Eng. Chem. Process Des. Dev.25 654-660.