

A Low-Profile Omnidirectional Planar Antenna with Vertical Polarization Employing Two In-Phase Elements

Jungsuek Oh¹, and Kamal Sarabandi¹

¹ Radiation Laboratory, Electrical Engineering and Computer Science Department
University of Michigan, Ann Arbor
1301 Beal Avenue Ann Arbor, MI 48109-2122, USA
{Jungsuek, saraband}@umich.edu

Abstract

A novel technique for designing a low-profile miniaturized omnidirectional planar antenna with vertical polarization is presented. The proposed antenna is designed using two short in-phase vertical elements. To achieve in-phase radiation the short vertical pins should be $\lambda/2$ away from each other. To minimize the $\lambda/2$ transmission line a T-type 180 degree phase shifter with a capacitive impedance inverter can be used. However, the drawback of using this phase shifter is the generation of an out-of-phase conduction current going vertically down through the capacitor. The radiated fields from the conduction current cancel out radiated fields from in-phase currents on the two vertical elements, leading to the suppression of vertically polarized radiation. In this study, the conduction current is eliminated by substituting the capacitor connected to the shorting via with an open stub. The geometry of the open stub is optimized to obtain appropriate capacitance values giving the antenna lateral dimensions ($\lambda/8 \times \lambda/8$) and height ($\lambda/40$). An important advantage of the proposed antenna is omnidirectional radiation pattern and high gain.

1. Introduction

Vertically polarized antennas with omnidirectional radiation pattern are highly desirable for many applications including near-ground communications among ad-hoc nodes of wireless devices used in vehicles or unattended ground sensors. The need for vertical polarization stems from the fact that near-ground propagation path loss between two near-ground antennas for vertically oriented antennas is by many orders of magnitude lower than any other antenna orientation configurations. Different types of low-profile antennas with omnidirectional radiation pattern have been proposed. Among these, one approach is to excite radiation from short segments of loaded vertical wires, and the other one is based on exciting a cavity-backed small slot loop antenna [1]–[3].

One way of improving the gain of low-profile vertically polarized antenna is to use multiple vertical elements in phase which is equivalent to having a vertical short dipole with higher height. Recently a compact and low-profile metamaterial ring antenna was proposed using two metamaterial unit cells [4]. In the paper, two metamaterial unit cells are used to reduce the electrical length between two in-phase vertical elements. However, its geometry is complicated and two vertical pins are located at the ends of the antenna structure, far away from the center.

In this paper, a simple approach is introduced to minimize the size of vertically polarized antennas with two in-phase vertical elements. Firstly, the values of two inductors and a capacitor in an ordinary T-type 180 degree phase shifter are appropriately chosen at 2.4GHz. Next, a capacitor connected to the ground is replaced by an open stub, eliminating an out-of-phase conduction current. Finally, for a given lateral dimension ($\lambda/8$) and height ($\lambda/40$), the miniaturized antenna structure is designed by optimizing the geometry of the open stub to get omnidirectional radiation pattern.

2. Size reduction of $\lambda/2$ Transmission Line for Antenna Miniaturization

A short-circuited $\lambda/2$ transmission line resonates and the shorting pins with large electric current can radiate vertically polarized field. The most important issue in designing miniaturized two in-phase elements is to reduce the length of the $\lambda/2$ transmission line. This section presents a new technique for it. Fig. 1(a) shows two vertical elements which are $\lambda/2$ away from each other. Currents flowing on two vertical pins are in phase because of 180 degree phase shift from the $\lambda/2$ transmission line. Its circuit model is shown in Fig. 1(b), assuming that small inductances from two vertical pins with very low profile ($\lambda/40$) are ignorable. Black arrows depict the direction of currents flowing at each probing point. To

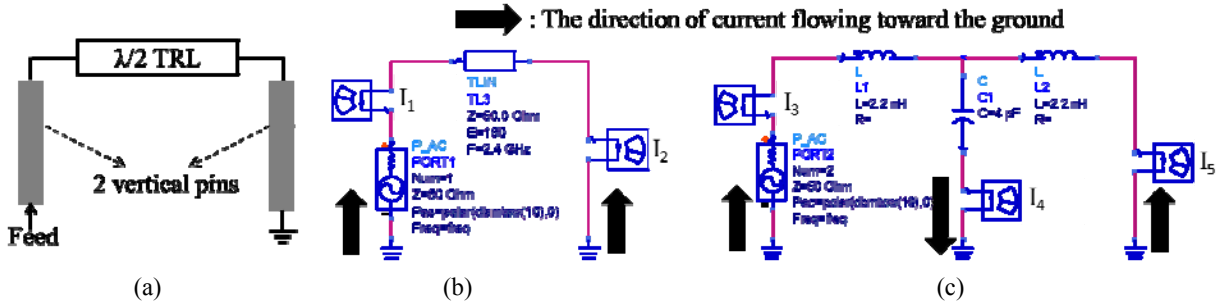

Figure 1. (a) Two vertical elements put $\lambda/2$ away from each other, (b) its circuit model and (c) a circuit model for a T-type 180 degree phase shifter.

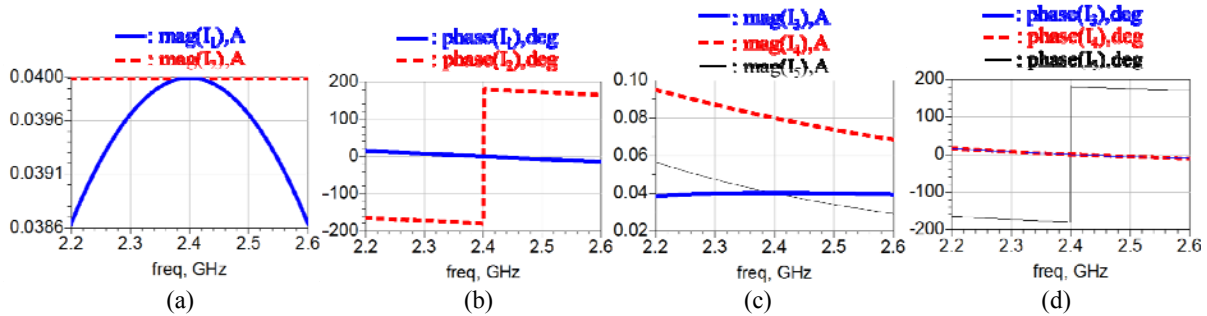

Figure 2. (a) Magnitudes of currents I_1 and I_2 , (b) phases of currents at I_1 and I_2 , and (c) magnitudes and (d) phases of currents I_3 , I_4 and I_5 shown in Fig. 1.

reduce lateral dimension of antenna structure, using a meandered metallic trace causes not only high ohmic loss but also the difficulty in accomplishing omnidirectional radiation pattern, leading to low radiation efficiency for the desired polarization. To minimize the $\lambda/2$ transmission line a T-type 180 degree phase shifter with an impedance inverter can be used, as shown in Fig. 1(c). However, it is pointed out that without modifying its schematic the topology can be applied to the design of vertically polarized antennas because a conduction current flowing along a via connected to a capacitor is out of phase as indicated by a black arrow shown in the middle point of schematic shown in Fig. 1(c). Fig. 2 shows the magnitude and phase of currents at each probing point in Fig. 1. As expected, at 2.4 GHz I_1 and I_2 have the same magnitude but 180 degree phase difference. However, at 2.4 GHz the phase of I_4 is 0 degree, which is out of phase compared to the phase of I_3 or I_5 . The magnitude (0.08A at 2.4GHz) of I_4 is twice that (0.04A at 2.4GHz) of I_3 or I_5 as shown Fig. 2(c) and (d). It means that radiated fields from the vertical current I_4 exactly cancel out radiated fields from two vertical currents at I_3 and I_5 , resulting in no vertically polarized radiation. Therefore, in order to employ this schematic for antenna miniaturization it is key to eliminate the conduction current path at I_4 , while maintaining the 180 degree phase shift required for I_3 and I_5 that radiate in phase.

In this study, a shorted capacitor generating an out-of-phase conduction current is substituted by an open-stub as shown in Fig. 3(b). Characteristic impedance and length of the open stub in the circuit schematic is appropriately chosen to achieve the required 180 degree phase shift at 2.4 GHz. Fig. 4 shows the magnitudes and phases of I_6 and I_7 , indicating the same magnitude and 180 degree phase difference.

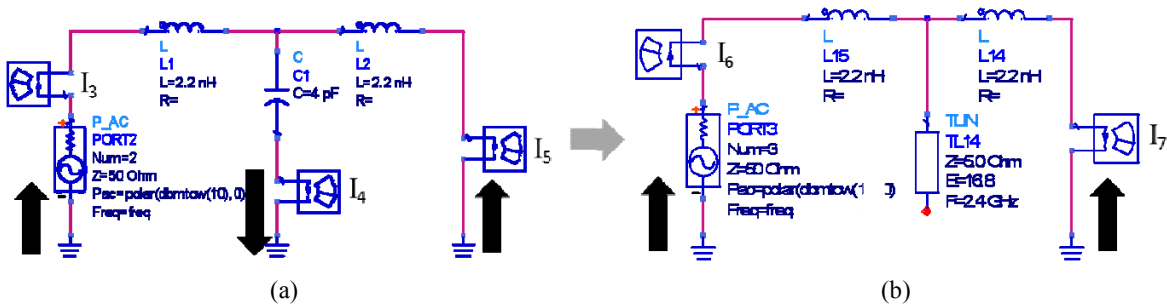

Figure 3. (a) The circuit model for a T-type 180 degree phase shifter, (b) the circuit model employing an open stub instead of a shorted capacitor in (a).

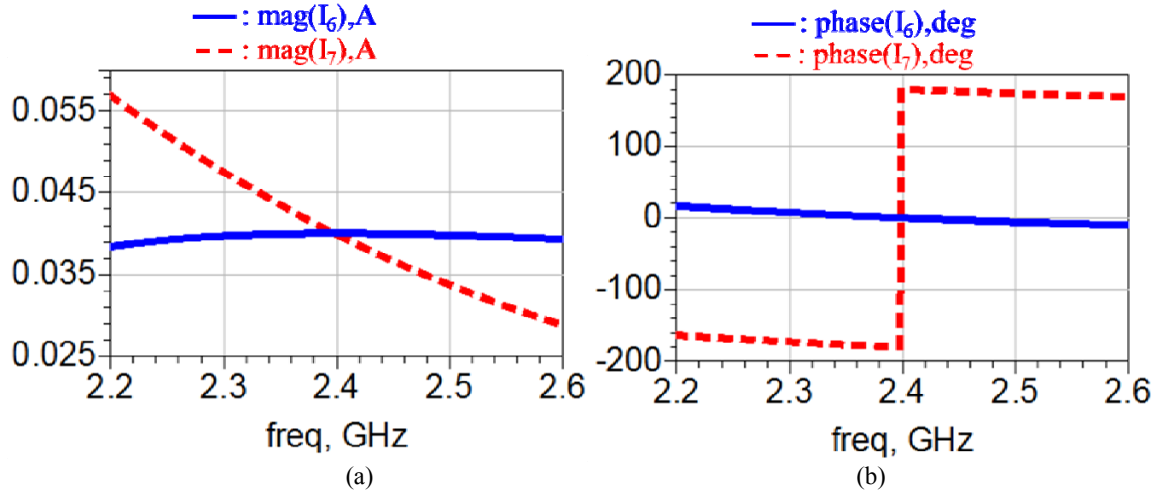

Figure 4. (a) Magnitudes and (b) phases of currents I_6 and I_7 shown in Fig. 3.

3. Antenna Design

Based on the analysis of the equivalent circuit shown in the previous section, a low-profile miniaturized antenna with two in-phase elements is designed. Fig. 5 shows the top view and side view of the proposed antenna. The lateral dimension and height of the proposed antenna are 15 mm ($\lambda/8$) and 3.175 mm ($\lambda/40$), respectively. The substrate used in this design has a dielectric constant of 2.2 and dielectric loss tangent of 0.0009. In order to consider actual ohmic loss, conductivity of copper is used in all metallic traces and vertical pins in the full-wave analysis. Fig. 5(a) shows the geometry of the optimized open stub and two inductors. In order to consider actual equivalent model of the inductors used in this design, equivalent series resistances (ESR) are extracted at 2.4 GHz and added to the simulation model. Also to get impedance matching, an extra shorting pin is added as shown in Fig. 5(b). By changing the distance between the shorting pin and the feeding pin, the input impedance can be controlled. The geometry of the open stubs on the top plate is chosen to be symmetric in terms of XZ and YZ planes and the positions of the three pins are at the center of antenna structure, enabling ideally omnidirectional radiation pattern.

Figures 6 and 7 show the S_{11} and the vertically polarized (E_θ) 3D radiation pattern, suggesting the good impedance matching and ideally omnidirectional radiation pattern. Fig. 7 shows the vertically polarized 2D radiation patterns on XZ plane (E-plane) and XY plane (H-plane). Vertically polarized antenna gain is computed as 0.5 dBi.

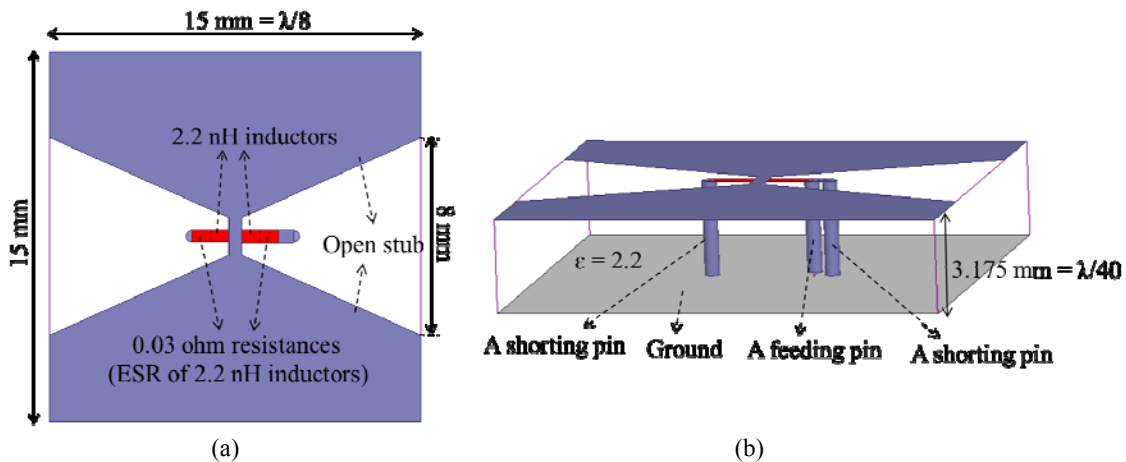

Figure 5. (a) Top view and (b) side view of the proposed antenna.

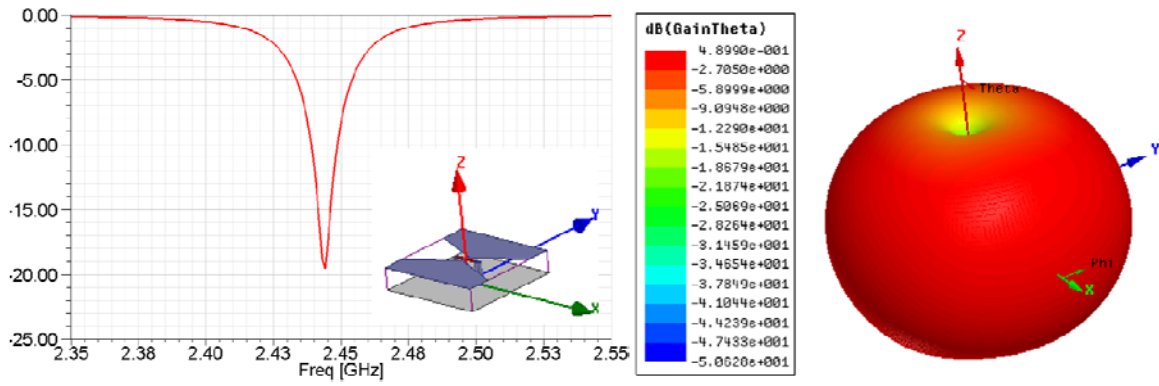

Figure 6. (a) S_{11} and (b) 3D vertically polarized radiation pattern (E_0)

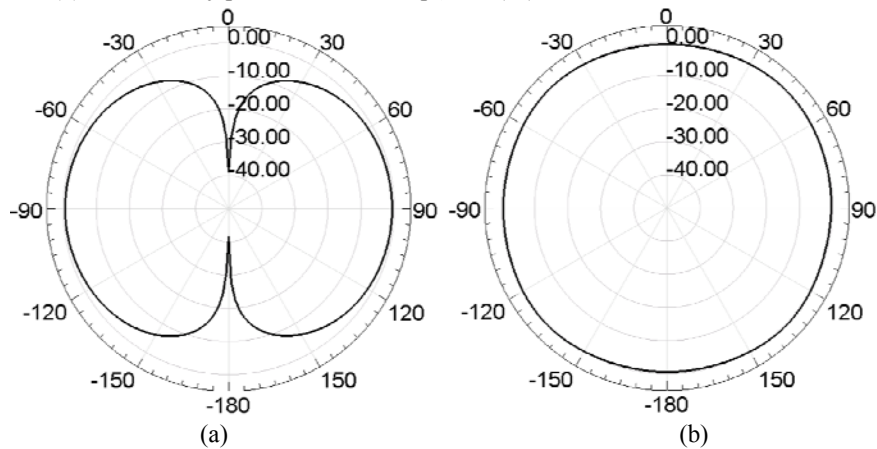

Figure 7. 2D vertically polarized radiation patterns on (a) XZ plane (E-plane) and (b) XY plane (H-plane).

4. Conclusion

A novel low-profile miniaturized antenna with vertical polarization and omnidirectional radiation pattern employing two in-phase elements is presented. The antenna operation is accomplished by substituting an impedance inverter capacitor which produces the required 180 degree phase shifter with an open stub. In this way, no conduction current in opposite direction to the radiating pins is generated. The lateral dimension and height of the proposed antenna are $\lambda/8$ and $\lambda/40$, respectively. A very high antenna gain of 0.5dBi is obtained. Using the proposed design procedure, the performance of further miniaturized antennas will be presented.

5. References

1. N. Behdad and K. Sarabandi, "Bandwidth enhancement and further size reduction of a class of miniaturized slot antennas," *IEEE Trans. Antennas Propag.*, vol. 52, pp. 1928-1935, 2004.
2. Liao, D. and K. Sarabandi, "Optimization of low-profile antennas for applications in unattended ground sensor networks," *IEEE Int. Symp. on Antennas Propag.*, pp. 783-786, 2006.
3. W. Hong, N. Behdad, K. Sarabandi, "Size reduction of cavity-backed slot antennas," *IEEE Trans. Antennas Propag.*, vol. 54, pp. 1461-1466, 2006.
4. F. Qureshi, M. A. Antoniadis, and G. V. Eleftheriades, "A compact and low-profile metamaterial ring antenna with vertical polarization," *IEEE Antennas Wireless Propag.*, vol. 4, pp. 333-336, 2005.