

APEX: Current Status of the Airborne Dispersive Pushbroom Imaging Spectrometer

Michael E. Schaepman^{*a}, Klaus I. Itten^a, and *The APEX Team*^b

^aRemote Sensing Laboratories, University of Zurich, Winterthurerstrasse 190, 8057 Zurich, Switzerland

^b*The APEX Team*: Daniel Schläpfer, Johannes W. Kaiser, Jason Brazile (RSL), Walter Debruyn (VITO, Mol, B), Andreas Neukom, Hans Feusi, Peter Adolph, Renzo Moser, Thomas Schilliger (HTS AG, Wallisellen, CH), Lieve De Vos, Guido Brandt (OIP, Oudenaarde, B), Peter Kohler, Markus Meng, Jens Piesbergen (Nectetera AG, Zurich, CH), Peter Strobl (DLR, Oberpfaffenhofen, GER), Jose Gavira, Gerd Ulbrich, and Roland Meynart (ESA, Noordwijk, NL)

ABSTRACT

Over the past few years, a joint Swiss/Belgium ESA initiative resulted in a project to build a precursor mission of future spaceborne imaging spectrometers, namely APEX (Airborne Prism Experiment). APEX is designed to be an airborne dispersive pushbroom imaging spectrometer operating in the solar reflected wavelength range between 400 and 2500 nm. The system is optimized for land applications including limnology, snow, and soil, amongst others. The instrument is optimized with various steps taken to allow for absolute calibrated radiance measurements. This includes the use of a pre- and post-data acquisition internal calibration facility as well as a laboratory calibration and a performance model serving as a stable reference. The instrument is currently in its breadboarding phase, including some new results with respect to detector development and design optimization for imaging spectrometers. In the same APEX framework, a complete processing and archiving facility (PAF) is developed. The PAF not only includes imaging spectrometer data processing up to physical units, but also geometric and atmospheric correction for each scene, as well as calibration data input. The PAF software includes an Internet based web-server and provides interfaces to data users as well as instrument operators and programmers. The software design, the tools and its life cycle are discussed as well.

Keywords: Imaging spectrometer; hyperspectral; pushbroom; calibration; validation; sensor design; data processing; imaging spectroscopy applications

1. INTRODUCTION

The Remote Sensing Laboratories (RSL) identified in 1996 the necessity to initiate a project that concentrates on the definition of an airborne imaging spectrometer which could represent a precursor mission to future planned spaceborne imaging spectrometers. This project includes the definition of an airborne dispersive pushbroom imaging spectrometer (named 'Airborne Prism Experiment' (APEX)) that will contribute to the preparation, calibration, validation, simulation, and application development for future imaging spectrometer missions in space [1], as well as to the understanding of land processes and interactions at a local and regional (or national) scale [2], in support for global applications [3]. The APEX project is implemented through ESA PRODEX (European Space Agency PROgramme de Developpement d'EXperiences Scientifiques), which aims at providing funding for the industrial development of scientific instruments or experiments proposed by institutes or universities, which have been selected by ESA for one of its programs in the various fields of space research (e.g., Earth observation). ESA usually provides both, administrative and financial-management, and technical support [4].

* schaep@geo.unizh.ch; phone +41 1 635 51 45; fax +41 1 635 68 46; www.apex-esa.org

The APEX project started in 1997 by performing a feasibility study on the design of an imaging spectrometer [5] and resulted in a first performance definition [6], and a subsequent design phase [7]. Currently, various parts of APEX are being finalized in design, breadboarding and performance analysis of the processing chain [8], and the subsequent construction of the instrument is planned to be final in 2005 [9].

2. TECHNICAL DESCRIPTION OF APEX

APEX will allow for a flexible aircraft integration scheme. Therefore the instrument is subdivided into three major assemblies (Assy 1: Pilot interface, operator interface, computer (rack); Assy 2: APEX spectrometer including thermal enclosure and inertial unit; Assy 3: data and power harness). The APEX instrument itself is subdivided into the following components (c.f., Figure 1): An operator cockpit and pilot interface (OCI), a flight management system (FMS), the navigational subsystem (NSS), the central computer consisting of the control and data storage unit (CSU), a stabilized platform (STP), on which the opto-mechanical unit (OMU) is mounted and the type specific platform and aircraft interface (STPA-IF). The instrument is designed to be fully self-contained and is programmable using a software interface. Ground support equipment (GSE) is designed to integrate and remove the instrument for aircraft fuselage and store (or transport) the instrument from the airfield to the calibration home base and its permanent storage location.

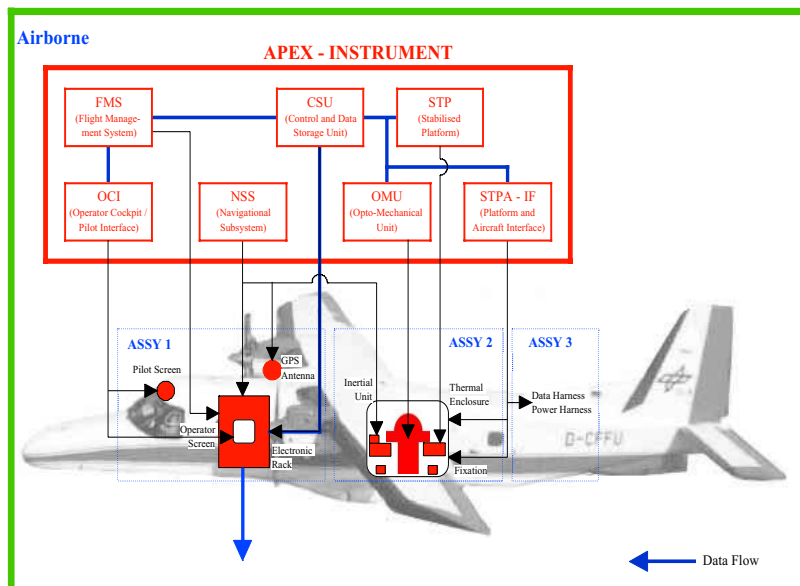

Figure 1. Schematic components and assemblies of APEX.

Technically, APEX is designed to be a dual prism dispersion pushbroom imaging spectrometer using a common ground imager with a slit in its image plane. The spectrometer consists of a collimator that directs the light transmitted by the slit towards the prisms, where a dichroic beam splitter separates the two spectrometer channels into the VNIR (Visible/Near Infrared, 380-1000 nm), and SWIR (Shortwave Infrared, 930-2500 nm) wavelength range. Following the dispersion of the prism (two for the VNIR, one for the SWIR), the spatially and spectrally resolved lines are re-imaged on the detector arrays. The light is dispersed onto 1000 spatial pixels across-track for both channels, with 312 spectral rows in the VNIR and 195 spectral rows in the SWIR. Flexible, reprogrammable binning on-chip will allow summarizing the spectral bands into a maximum of 300 spectral rows for both detectors. Figure 2 depicts to the left the OMU (the optical base plate with the spectrometer inside the optical subunit has been removed for clarity) and to the right the dual prism pushbroom spectrometer design.

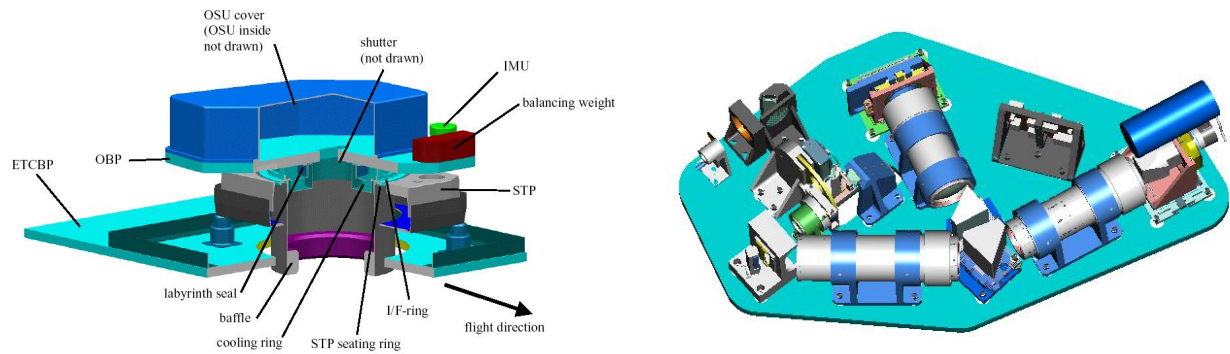

Figure 2. Left: APEX assembly of the opto-mechanical unit (OMU) without the spectrometer drawn. Right: Optical base plate (OBP) with spectrometer details (right: SWIR detector, top: VNIR detector, top left: ground imager and filter wheel, bottom left: collimator, center: dual prisms).

An integral part of the spectrometer is a built-in ‘In-Flight’ Calibration facility (IFC), where a mirror will be shifted in the optical path to reflect the light of the internal stabilized QTH (Quartz Tungsten Halogen) lamp / integrating sphere combination in the optical path of the spectrometer using a filter-wheel, a fiber bundle and a diffuser. The filters will be a set of quartz filters with rare earth doping components for spectral calibration and another set with different transmission properties without distinct spectral absorption features for radiance calibration. This setup will be used just before and after a regular data take in the form of a secondary calibration standard.

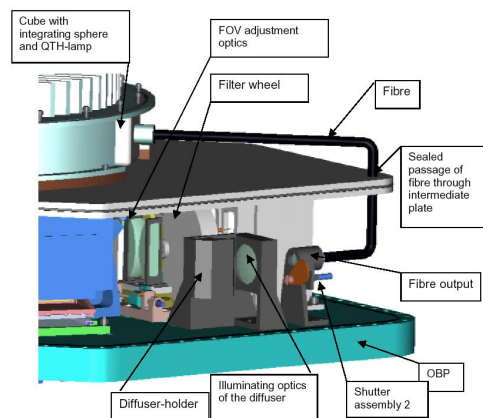

Figure 3. APEX in-flight calibration (IFC), detailed view.

The front end electronics of APEX are designed to support frame rates up to 43.4 Hz, and are located as close as possible to the detectors. After the analogue-digital conversion and the multiplexer of each spectral channel, the data is processed in an FPGA (Field Programmable Gate Array) to a stream of 16 bit words, which are then serialized and transmitted over an optical high-speed link at 700 Mbit/s. This link connects the APEX optical and mechanical structure to the operator’s console and computer.

The control and storage unit (CSU) of APEX is a dedicated rack in the aircraft, that hosts all the instrumentation required to operate APEX - in particular, the flight management system with an interface to the operator and the pilot, the inertial navigation system and the GPS (Global Positioning System) processor, and the computer that interfaces the optical unit (connected over the high-speed link) and the storage unit (c.f., Figure 4, right). Most of the components used in this setup are commercially available, apart from a dedicated PCI (Peripheral Component Interconnect) card, which is needed to connect the optical unit through a PCI-bus interface to the host system. The host system (c.f., Figure 4, left) is composed of a commercial Intel server board with a 2 GHz Intel Xeon CPU (Central Processing Unit), 2 GByte of RAM (Random Access Memory), a dual-channel ultra-320 SCSI (Small Computer System Interface) controller (64bit/133Mhz PCI) and 6 x 72 GByte Ultra-160 SCSI hard disks. The data exchange between the incoming data from the PCI card and the hard

disks are implemented using multi-threaded shared memory architecture to ensure data throughput. The maximum transfer rate of the system is limited by the PCI bus bandwidth, nevertheless breadboarding activities have demonstrated sufficient margin available.

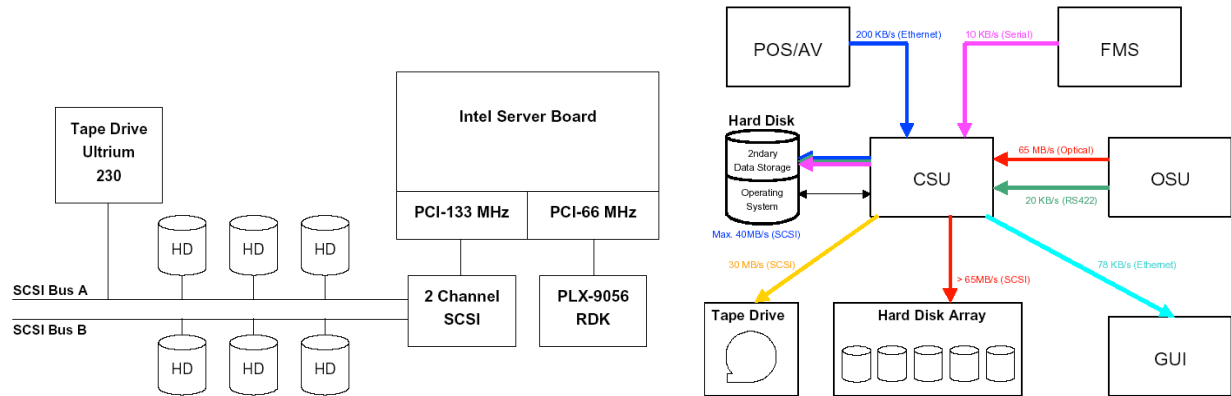

Figure 4. APEX schematic electronic setup (left) and data streams block diagram (right).

The CSU is driven by control software that is composed of low level interfaces (e.g., the disk read/write interface, etc.), a middle tier that handles the logging and alerting, the configuration of APEX operating modes using a configuration data base, and the operator interface, where system configuration, status, and a waterfall image are displayed during data takes. The control software also includes the synchronization mechanisms of the various subparts. The data acquisition in the aircraft has been analyzed and the initial system analysis indicated three critical engineering problems that needed to be addressed to ensure successful data takes [10]:

First, the data throughput from the OSU to the CSU and finally to the hard disk array occurs at a rate which exceeds 'common' single disk sustained write data rates. Second, the low volume but high rate (25 messages per second) 'housekeeping' data delivered via a typically interrupt driven serial interface causes a throughput vs. latency contingency, which complicates our requirement to not lose any data from these streams. And finally, the synchronization of various time signals from devices taking independent data samples need to be correlated and rectified with the notion of a common clock.

In order to address these items properly, the electronic setup as depicted in figure 4 was implemented as a breadboard and tests are run on this configuration using the data acquisition architecture as indicated in figure 5. The test was run with 5 writers to 5 disks over the entire capacity of the disks, and the throughput was measured every 5 frames. There is a large performance variation depending on the area of the disks being written to. However the maximum performances measured are 115.1 MB/s and the minimum 85.7 MB/s. The CPU load during the test showed 65% idle time and 35% system time.

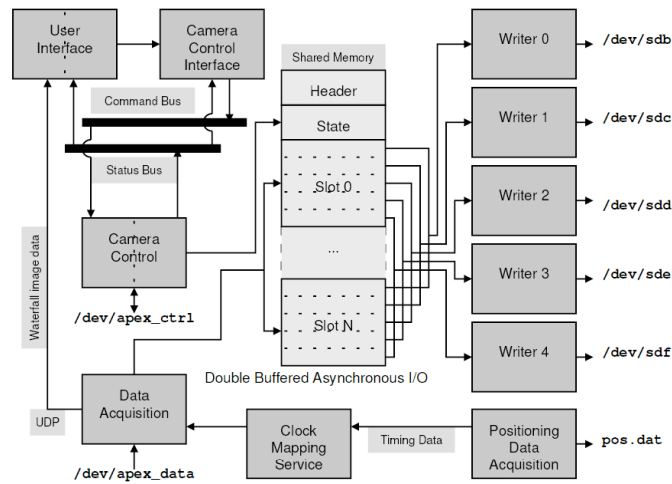

Figure 5. Subset of data acquisition architecture.

The CSU racks will also host a power distribution unit that acts as an interface between the aircraft power supply and the different APEX subsystems. The optical system will also be supported by a stabilized platform and a thermal control that maintains constant temperature while operating the instrument.

The APEX system has been specified as a combination of user requirements, which have been derived from a survey of imaging spectroscopy applications [11] and a subsequently derived forward performance model based on these requirements [12][13]. However, the development is limited through some budgetary constraints, development time and availability of latest technologies. The specifications - as listed in the following figure 6 - need therefore to be understood as a general frame for imaging spectrometer development. The final instrument performance will be transmitted to the user after successful validation of the in-flight and laboratory performance.

Figure 6. APEX Specifications

Specified Parameter	Value
Field of View (FOV)	$\pm 14^\circ$ deg
Instantaneous Field of View (IFOV)	0.48 mrad
Flight altitude	4'000 - 10'000 m.a.s.l.
Spectral channels	VNIR: approx. 140, SWIR: approx. 145
Spectral range	400 – 2500 nm
Spectral sampling interval	400 – 1050 nm: < 5 nm, 1050 – 2500 nm: < 10 nm
Spectral sampling width	< 1.5 * Spectral sampling interval
Center wavelength accuracy	< 0.2 nm
Spectral sampling width accuracy	< 0.02 * Spectral sampling width
PSF (Point Spread Function)	≤ 1.75 * Sampling interval
Smile	< 0.1 pixel
Frown	< 0.1 pixel
Bad pixels	None (requirement after electronics)
Scanning mechanism	Pushbroom
Absolute radiometric calibration accuracy	$\leq 2\%$

Storage capacity on board (online / offline)	> 50 GByte / > 200 GByte
Dynamic Range	12 ... 16 bit
Positional knowledge	20% of the ground sampling distance
Attitude knowledge	20% of IFOV
Navigation system, flight line repeatability	± 5% of FOV
Positional and attitude data	Recording of data onto a housekeeping channel.
Reliability	99% successful data acquisitions for all flights

3. EXTERNAL FACILITIES TO APEX

APEX will also be supported by three major external facilities. This includes a Calibration Home Base (CHB) with dedicated spectral, radiometric and geometric calibration facilities for full laboratory characterization and calibration of APEX. The calibration home base is located in Oberpfaffenhoffen at DLR near Munich (Germany).

The APEX operational center is located in Mol (Belgium) and hosted by VITO. All user interactions (flight requests, archived data search, flight planning, user support, etc.) are carried out from this location.

Finally the APEX Processing and Archiving Facility (PAF) manages the data from acquisition and calibration to processing and dissemination. The processing chain is based on analyzing in-flight acquired image data, housekeeping information (e.g., navigation data, temperature), and on-board calibration data (using the above mentioned IFC). Moreover, the CHB allows the characterization and calibration of the geometric, radiometric and spatial sensor characteristics. Using the outcome of the sensor calibration, the raw image data are converted to at-sensor radiance in SI (le Systeme international d'unites) units, traceable to a certified standard (e.g., NIST, NPL). The second major step derives surface reflectance under consideration of the environmental conditions. Optional HDRF (Hemispherical Directional Reflectance Factor) correction algorithms are later used to convert the directional reflectance values into nadir-normalized reflectance. The derivation of scientific data products is supported using a flexible plug-in structure in the PAF and documented in standard ATBD's (Algorithm Theoretical Basis Document).

It was determined that if the control logic of the PAF is developed in a high level meta-programming environment, then this environment could be used to access and integrate the strengths of many other special purpose rapid prototyping environments. The direct affect of providing a highly "multi-lingual" development environment is the ability to enable mixed-level domain application development. The development team for such an application can consist of spectroscopy experts developing core algorithms with IDL (Interactive Data Language) and possibly other mathematical modeling languages; database experts developing data models and queries in SQL (Structured Query Language); user interface experts developing graphical (graphical user interface toolkit (Tk), widget based) and web (HTML- HyperText Markup Language) front ends; software architects analyzing overall program and data flow to maximize not just efficiency but flexibility - for example allowing calls to special-purpose CORBA-based (Common Object Request Broker Architecture) services in the processing chain; and finally software engineers which ensure that everything glues together and can help find and re-work bottlenecks.

There are three noteworthy features of the PAF software development process - an iterative prototype-based development model, the amount and method of multi-environment integration, and the accommodation of mixed-level domain development contributions.

A large application with so many stakeholders is often subject to design and implementation setbacks resulting from 'specification by committee'. Two approaches have been taken to actively counter these risks and to ensure the coherency of the overall design. First, a prototype-based, iterative development model has been selected. The first iteration consists of simulating program flow using high level prototyping languages and subsequent iterations involve refining the simulated steps by gradually replacing them with more realistic modules - more realistic first in terms of data

size and shape and then in terms of processing resource requirements. The PAF is expected to continually undergo such additions and refinements but at every iteration a coherent understandable design and a realistic working process will be given highest priority. In addition, it is planned to take a modified SPID (Statistically Planned Incremental Deliveries) approach during the planning for each iteration, where the planned tasks are reviewed and statistical estimates are upgraded for the best, most-likely, and worst case scenarios to help prioritize and re-align the project plan for that iteration.

It is expected that individual flight campaigns will collect data on the order of 100s of GB that need to undergo an offline chain of data correction and characterization processes based on previously acquired and in-flight calibration parameters. This processing chain includes conversion of raw data values into SI units, bad pixel replacement, and corrections of smear, stray light, smile and frown anomalies. A simplified block diagram of the planned processing is illustrated in figure 7. The data acquisition process described in the previous section produces the top four components on the left side in the Raw Data column. The lower two components are produced during inter-mission calibration of the instrument which takes place in the CHB.

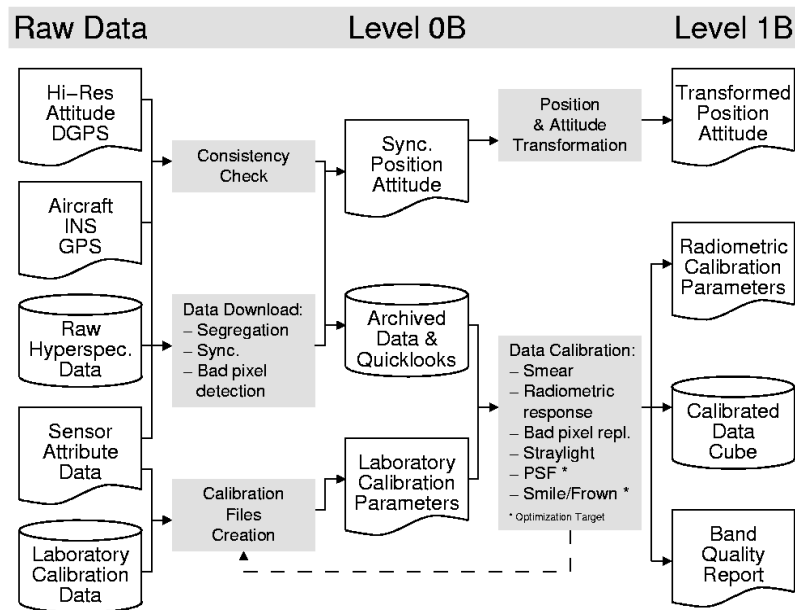

Figure 7. Generalized post-processing data flow.

At this point all of the raw data is still present in the onboard computer and needs to be transferred to the off-line PAF computer. During this data transfer, quick consistency checks are made, and some simple constant-time operations can be performed such as bad pixel detection as well as generation of a high-resolution composite RGB pseudo-color quick-look image. During this data download phase, some intermediate files are created for use during scientific data calibration processing phase, which ultimately produces what is known as the level 1B data product.

Essential post-processing algorithms for imaging spectrometer data calibration and analysis are usually developed by scientists using special purpose high-level data modeling languages such as TMW's MATLAB [14] and RSI's IDL [15]. Because many of these correction and calibration algorithms are an active topic of research, it was strongly desired to leave scientifically sensitive processing algorithms in their original modeling language as much as possible to facilitate peer-reviewed validation as well as the ability to easily incorporate updates according to the latest advances. But while these languages are often ideal for their domain, they often don't provide convenient interfaces to interesting external software components such as relational database management systems, web servers, and cluster framework libraries. However, these modeling languages do often provide a C programming interface to their internals allowing them to be embedded into other applications. This is certainly true in the cases of MATLAB and IDL [16].

A small experiment was developed to investigate the feasibility of embedding an IDL interpreter inside a Tcl interpreter in order to allow program logic to be developed in Tcl, while allowing scientific algorithms to be processed in IDL. The experiment involved developing an `idl.so` Tcl extension, which allowed creation of an interpreter and invocation of commands as strings, and combining it with the `websh.so` [17] Tcl extension in order to implement an interactive web interface to an IDL command line. The user was able to enter arbitrary IDL commands into a form entry screen, which was processed by the embedded IDL interpreter and the results formatted in HTML for display in a web browser. When this experiment proved successful, additional commands for importing and exporting numerical arrays to/from IDL were added to the `idl.so` extension in order to be able to directly pass data to other Tcl extensions.

The proof-of-concept mentioned above was extended to allow access to an RDBMS (relational database management system) by way of the `mysql.so` Tcl extension to allow for browsing and/or querying the hyperspectral data archive. It was then extended with the `tdom.so` to allow for parsing, manipulation, and writing of XML based meta data for information that is expected to be shared with other (external) processing systems. It has been determined that even with the large data volumes involved, most of the basic scientific level 1 processing can be performed within the allowed time constraints using a single server class computer. However, it is possible that smile/frown and point spread anomalies that need to be corrected by re-sampling in both the spatial and spectral dimensions simultaneously might require enough processing power to merit the use of cluster processing. Investigation of the particular problems and possible correction algorithms are currently underway. In the case that processing would benefit from cluster computing, experimentation with a Tcl extension to allow access to the MPI-C (Message Passing Interface) library is tentatively planned.

The current version of the prototype kernel is illustrated in figure 8. An additional requirement of the processing system is that key calibration algorithms should be documented and that this documentation should be updated whenever the algorithm is updated. While some argue that IDL is a high enough level language to be self-documenting, this argument doesn't meet typical software engineering standards. Therefore, an IDL documentation system similar to Java's javadoc was developed to allow programmers to embed documentation inside comments in the code itself. This includes standard tags for things such as describing inputs, outputs, and side effects.

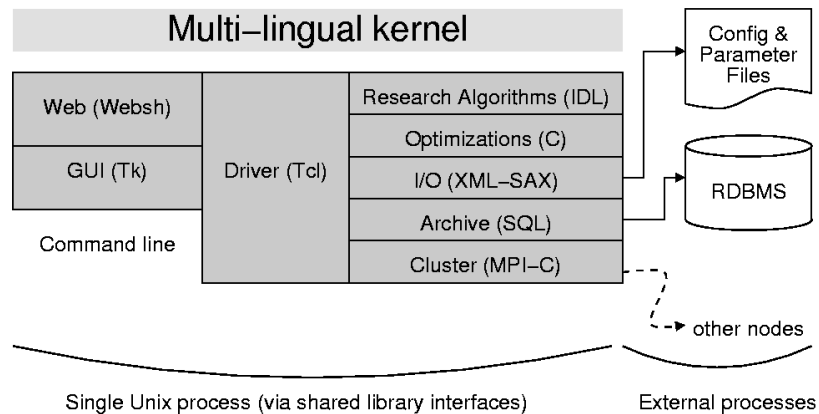

Figure 8. Subset of data acquisition architecture.

4. CONCLUSIONS

Terrestrial ecosystems have been identified as being a critical component of the variability of the global carbon cycle. But given the natural diversity of landscapes, the instrumented measurement and validation approach remains challenging. Earth observation from airborne or spaceborne platforms is the only observational approach capable of providing data at the relevant scales and resolution needed to extrapolate findings of in situ (field) studies to larger areas,

to document the heterogeneity of the landscape at regional scale and to connect these findings into a global view. Recent development of Earth observation satellites and airborne platforms demonstrate that imaging spectroscopy is a valuable addition to the quantification of relevant parameters supporting processes within the carbon cycle [2][3]. Even though a number of imaging spectrometers are available in space (e.g., MODIS, MERIS, Hyperion, etc.), their performance relies on an integrated approach, including a sound instrument design, a well implemented calibration strategy and finally a processing chain capable of handling large amount of spectral data. Only a wide and fast dissemination of spectrometer data and their products will guarantee the required scientific attention and their inclusion in operational Earth observation systems. The presented APEX system will be a significant contribution to address the above said in a quantitative and qualitative manner.

ACKNOWLEDGEMENTS

The work in this paper is being carried out under ESA/ESTEC contracts no. 16298/02/NL/US and 15449/01/NL/Sfe. The support of the University of Zurich is acknowledged.

REFERENCES

1. Nieke, J., Schwarzer, H., Neumann, A., and Zimmermann, G., "Imaging Spaceborne and Airborne Sensor Systems in the Beginning of the Next Century,,," in: Proc. SPIE, Vol. 3221, 581-592, Sensor, Systems and Next Generation Satellites III, 1997.
2. Schaepman, M., Itten, K., and Rast, M., „Imaging Spectroscopy as a Quantitative Tool for the Retrieval of Biogeophysical Parameters,,," Geographica Helvetica, Vol. 58(2), 120-130, 2003.
3. Rast, M., et al., "SPECTRA – Surface Processes and Ecosystem Changes Through Response Analysis,,," ESA Reports of Assessment, SP-1257(5), p. 126, 2001.
4. ESA, http://www.esa.int/export/esaCP/ASE0QUNW9SC_Benefits_0.html, Visited July 2003.
5. Itten, K.I., Schaepman, M., De Vos, L., Hermans, L., Schlaepfer, H., and Droz, F., "APEX – Airborne PRISM Experiment: A new concept for an airborne imaging spectrometer,,," in: Proc. ERIM, Vol. 1, 181-188, 3rd Intl. Airborne Remote Sensing Conference and Exhibition, 1997.
6. Schaepman, M., De Vos, L., and Itten, K.I., "APEX – Airborne PRISM Experiment: Hyperspectral radiometric performance analysis for the simulation of the future ESA Land Surface Processes Earth Explorer Mission,,," in: Proc. SPIE, Vol. 3438, 253-262, Imaging Spectrometry IV, 1998.
7. Schaepman, M., Schläpfer, D., and Itten, K., "APEX – A New Pushbroom Imaging Spectrometer for Imaging Spectroscopy Applications: Current Design and Status,,," in: Proc. IGARSS, 828–830, Hawaii, 2000.
8. Schaepman, M., Schläpfer, D., Brazile, J., and Bojinski, S., „Processing of large-volume airborne imaging spectrometer data: the APEX approach,,," in: Proc. SPIE, Vol. 4816, 72-76, Imaging Spectrometry VIII, 2002.
9. Schaepman, M., Itten, K.I., and The APEX Team, "Status of the Airborne Dispersive Pushbroom Imaging Spectrometer APEX (Airborne Prism Experiment),," Proc. IGARSS, Vol. VII, 4303-4306, Toulouse, 2003.
10. Brazile, J, Kohler, P., and Hefti, S., "A Software Architecture for In-flight Acquisition and Offline Scientific Post-Processing of Large Volume Hyperspectral Data,,," Proc. 10th USENIX Tcl/Tk Conference, CD-ROM, Ann Arbor (MI), 2003, in print.
11. Schaepman, M. et al., "Performance and Calibration Requirements for APEX - Summary Final Report,,," ESA/ESTEC Contract–No. 14906/00/NL/DC, p. 28, 2001.
12. Schaepman, M., D. Schläpfer, and A. Muller, Performance Requirements for Airborne Imaging Spectrometers, Proc. SPIE, Vol. 4480, 23–31, Imaging Spectrometry VII, 2001.
13. Schläpfer, D. and Schaepman, M., Modelling the noise equivalent radiance requirements of imaging spectrometers based on scientific applications. Appl. Optics 41(27): 5691-5701, 2002.
14. The MathWorks, Matlab, <http://www.mathworks.com/>, Visited July 2003.
15. Kodak Research Systems, Interactive Data Language, <http://www.rsinc.com/idl/>, Visited July 2003.
16. Brazile, J., Schaepman, M., Schläpfer, D., Kaiser, J, and Itten, K., "A Beowulf-Style Cluster Processing Concept for Large Volume Imaging Spectroscopy Data,,," Proc. Systemics, Cybernetics, and Informatics, Vol. X, 17-20, Orlando, 2003.
17. Vckovski, A., Brunner, R., and Hefti, S., Websh: The Tcl web application framework, <http://tcl.apache.org/websh>, Visited July 2003.