

WAVE LOADINGS ON A VERTICAL CYLINDER DUE TO HEAVE MOTION

D. D. BHATTA and M. RAHMAN

Department of Applied Mathematics
Technical University of Nova Scotia
Halifax, B3J 2X4, Canada.

(Received December 17, 1992 and in revised form June 6, 1993)

ABSTRACT. Wave forces and moments due to scattering and radiation for a vertical circular cylinder heaving in water of finite depth are derived analytically. These are derived from the total velocity potential which can be decomposed as two velocity potentials; one due to scattering in the presence of an incident wave on fixed structure (diffraction problem), and the other due to radiation by the heave motion on calm water (radiation problem). For each part, the velocity potential is derived by considering two regions, namely, interior region and exterior region. The complex matrix equations are solved numerically to determine the unknown coefficients to compute the wave loads. Some numerical results are presented for different depth to radius and draft to radius ratios.

KEY WORDS AND PHRSES. Scattering, radiation, heave motion, velocity potential.

1992 AMS SUBJECT CLASSIFICATION CODES. 76B15.

1. INTRODUCTION.

The estimation of hydrodynamic forces on an offshore structure has received considerable attention from the designers. Accurate prediction of the wave loads exerted by surface waves on rigid structures is absolutely necessary to design offshore structures. A rigid floating structure may undergo six degrees of freedom : three translational and three rotational. Assuming a suitable coordinate system, OXYZ, the translational motions in the x,y and z directions are referred as surge, sway and heave respectively; and the rotational motions about x,y and z axes are referred as roll, pitch and yaw respectively. Here z axis is considered to be vertically upwards from its still water level. Often the structure is restrained to have fewer degrees of freedom due to the type of mechanical connection used to fasten it to the seafloor. The problem of scattering of surface waves by a circular dock was carried out by Miles and Gilbert [8] and then by Garrett [3]. Garrett presented the results for the horizontal and vertical force and moment on the dock. Black, Mei and Bray [2] have calculated the wave forces on a truncated cylinder which either extends to the free surface or rests on the seabed. Isaacson [6] extended Garrett's method for a submerged truncated cylinder sitting on the sea-bed. The hydrodynamic interactions due to wave scattering between the numbers of an array of stationary, truncated cylinders have been investigated by Williams and Demirebilek [10].

Numerical results for the added mass and damping coefficients of semi-submerged two-dimensional heaving cylinders in water of finite depth were presented by Bai [1]. He showed that the added mass is bounded for all frequencies in water of finite depth. He studied the limits of the added mass and

damping coefficients for high and low frequencies. Yeung [12] presented a set of theoretical added masses and damping coefficients for a floating circular cylinder in finite-depth water. Sabuncu and Calisal [9] obtained hydrodynamic coefficients for vertical cylinders at finite water depth. Williams and Abul-Azm [11] investigated the hydrodynamic interactions between the members of an array of floating circular cylinders which occur when one member undergoes prescribed forced oscillations. Numerical results for the added mass of bodies heaving at low frequency in water of finite depth were also presented by McIver and Linton [7]. Garrison [4] presented a numerical method for the computations to determine wave excitation forces as well as added mass and damping coefficients for large objects in water of finite depth. He [5] presented a numerical analysis for the motion of large free-floating bodies.

We assume that the fluid is incompressible, the fluid motion is irrotational and the waves are of small amplitude. Here we consider the coefficients related to the motion with one degree of freedom, namely, translational motion in the z direction, i.e. heave. In this paper we have presented the analytical solution for the boundary value problem to evaluate the forces and the moments for a vertical circular cylinder heaving in water of finite depth. Numerical results are also presented.

2. MATHEMATICAL FORMULATION.

We consider a surface wave of amplitude A incident on a vertical circular cylinder of radius a in water of finite depth h . The body is assumed to be heaving with heave amplitude ξ in the presence of incident wave with angular frequency σ . The wave is parallel to x -axis at the time of incidence on the cylinder and propagating along $+ve$ direction. The draft of the cylinder in water is b . The geometry is depicted in Figure 1. We consider the cylindrical coordinate system (r, θ, z) with z vertically upwards from the still water level (SWL), r measured radially from the z -axis and θ

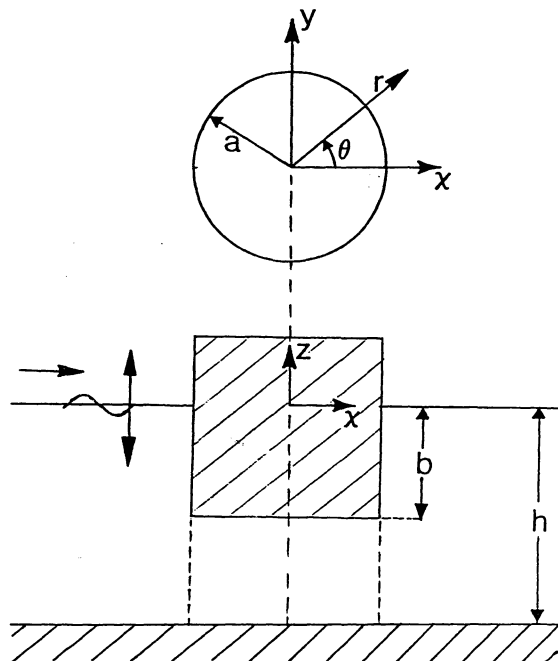

FIGURE 1. Definition sketch.

from the positive x -axis. For an incompressible and inviscid fluid, and for small amplitude wave theory with irrotational motion, we can introduce a velocity potential $\Phi(r, \theta, z, t)$. This Φ can be written as

$$\Phi(r, \theta, z, t) = \text{Re}[\phi(r, \theta, z)e^{-i\sigma t}].$$

From Bernoulli's equation we get pressure, $P(r, \theta, z, t)$, as

$$P = -\rho \frac{\partial \Phi}{\partial t}.$$

The force components F_x, F_y, F_z along x, y, z directions are given by

$$\begin{aligned} F_x &= - \int_{\theta=0}^{2\pi} \int_{-b}^0 P(a, \theta, z, t) a \cos \theta dz d\theta \\ F_y &= - \int_{\theta=0}^{2\pi} \int_{-b}^0 P(a, \theta, z, t) a \sin \theta dz d\theta \\ F_z &= \int_{\theta=0}^{2\pi} \int_0^a P(r, \theta, -b, t) r dr d\theta \end{aligned}$$

respectively. Since the incident wave is parallel to x -axis at the time of incidence, the nonzero horizontal component is F_x . The moment M_s arising due to the forces on the sides on the cylinder about sea-bottom and M_b arising due to the forces at the bottom of the cylinder about z -axis are given by

$$\begin{aligned} M_s &= - \int_{\theta=0}^{2\pi} \int_{-b}^0 (z + h) P(a, \theta, z, t) a \cos \theta dz d\theta \\ M_b &= \int_{\theta=0}^{2\pi} \int_0^a P(r, \theta, -b, t) r^2 dr d\theta \end{aligned}$$

respectively. Because of the linearity of the situation, the velocity potential ϕ can be decomposed into two velocity potentials ϕ_d and ϕ_r where ϕ_d is the velocity potential due to the scattering problem of an incident wave acting on the fixed cylinder, and ϕ_r due to the radiation problem of the cylinder forced to oscillate in otherwise still water. Thus ϕ can be written as

$$\phi = \phi_d + \hat{\xi} \phi_r$$

where $\xi = \text{Re} [\hat{\xi} e^{-i\sigma t}]$. Now by dividing the whole fluid domain into two domains, (a) interior domain : region below the cylinder i.e. $r \leq a$, $-h \leq z \leq -b$; (b) exterior domain : region for $r \geq a$ and $-h \leq z \leq 0$, we write the velocity potential for the interior domain as ϕ^i and the velocity potential for the exterior domain as ϕ^e . Then F_x, F_z, M_s, M_b can be written as the real part of $f_x e^{-i\sigma t}, f_z e^{-i\sigma t}, m_s e^{-i\sigma t}, m_b e^{-i\sigma t}$ respectively where f_x, f_z, m_s, m_b are given by

$$f_x = -i\rho\sigma a \int_{\theta=0}^{2\pi} \int_{-b}^0 \{ \phi_d^e(a, \theta, z) + \hat{\xi} \phi_r^e(a, \theta, z) \} \cos \theta dz d\theta \tag{1}$$

$$f_z = i\rho\sigma \int_{\theta=0}^{2\pi} \int_0^a \{ \phi_d^i(r, \theta, -b) + \hat{\xi} \phi_r^i(r, \theta, -b) \} r dr d\theta \tag{2}$$

$$m_s = -i\rho\sigma a \int_{\theta=0}^{2\pi} \int_{-b}^0 (z + h) \{ \phi_d^e(a, \theta, z) + \hat{\xi} \phi_r^e(a, \theta, z) \} \cos \theta dz d\theta \tag{3}$$

$$m_b = i\rho\sigma \int_{\theta=0}^{2\pi} \int_0^a \{ \phi_d^i(r, \theta, -b) + \hat{\xi} \phi_r^i(r, \theta, -b) \} r^2 dr d\theta \tag{4}$$

respectively.

Now the boundary value problem to be solved here is

$$\nabla^2 \phi = 0 \tag{5}$$

$$\sigma^2 \phi - g \frac{\partial \phi}{\partial z} = 0 \quad \text{on } z = 0 \quad r \geq a \tag{6}$$

$$\frac{\partial \phi}{\partial z} = 0 \quad \text{on } z = -h \tag{7}$$

$$\frac{\partial \phi}{\partial z} = -i\sigma \hat{\xi} \quad \text{on } z = -b \quad 0 \leq r \leq a \tag{8}$$

$$\frac{\partial \phi}{\partial r} = 0 \quad \text{on } r = a \quad -b < z < 0. \tag{9}$$

The boundary condition (8) can be separated into two conditions by writing as

$$\frac{\partial \phi_d}{\partial z} = 0 \quad \text{on } z = -b \quad 0 \leq r \leq a \tag{10}$$

$$\frac{\partial \phi_r}{\partial z} = -i\sigma \quad \text{on } z = -b \quad 0 \leq r \leq a. \tag{11}$$

Now we consider this problem by separating it into two problems, diffraction problem and radiation problem. The diffraction problem will give us the exciting force and from the radiation problem we will get the radiated force in terms of added mass and damping coefficients.

3. DIFFRACTION PROBLEM.

In this case the velocity potential satisfies the governing equation (5) and the boundary conditions (6), (7), (9), and (10). Also scattered potential ϕ_S (where $\phi_d = \phi_I + \phi_S$) must satisfy the radiation condition :

$$\lim_{r \rightarrow \infty} \sqrt{r} \left\{ \frac{\partial \phi_S}{\partial r} - i\lambda_0 \phi_S \right\} = 0$$

where λ_0 is the wavenumber and ϕ_I is the incident wave velocity potential. We solve this boundary value problem by constructing the representation of ϕ_d in the interior domain (under the cylinder) and the exterior domain ($r > a$) in the following section. Let us assume a product solution

$$\phi_d(r, \theta, z) = \sum_m Z(z) R(r) \cos m\theta$$

$m = 0, 1, 2, \dots$. Now we present solutions for the interior region and exterior region.

3.1 Interior and exterior solutions.

Using the method of separation of variables, a physically acceptable general solution for the interior region can be constructed as follows :

$$\phi_d^i = \sum_{m=0}^{\infty} \left[\frac{p_{m0}}{2} \left(\frac{r}{a}\right)^m + \sum_{n=1}^{\infty} p_{mn} \frac{I_m(k_n r)}{I_m(k_n a)} \cos k_n(z+h) \right] \cos m\theta \tag{12}$$

valid for $-h \leq z \leq -b$ and $r \leq a$; where p_{mn} , ($n = 0, 1, 2, \dots, m = 0, 1, 2, \dots$) are arbitrary constants. Here $k_n = \frac{n\pi}{h-b}$, $n = 1, 2, \dots$ are the eigen values and $I_m(k_n r)$ is the modified Bessel function of first kind and order m . It is to be noted here in obtaining this expression for ϕ_d^i that we have discarded the terms involving $(\frac{r}{a})^m, \ln(\frac{r}{a})$, because of their singular nature near the origin. It will be convenient later if we define

$$\zeta_m^i(r, z) = \frac{p_{m0}}{2} \left(\frac{r}{a}\right)^m + \sum_{n=1}^{\infty} p_{mn} \frac{I_m(k_n r)}{I_m(k_n a)} \cos k_n(z+h)$$

such that at $r = a$, it becomes a half-range Fourier cosine series expansion

$$\zeta_m^i(a, z) = \frac{p_{m0}}{2} + \sum_{n=1}^{\infty} p_{mn} \cos k_n(z + h) \tag{13}$$

defined in $-h \leq z \leq -b$.

Here p_{mn} 's are the Fourier coefficients and these coefficients are obtained from

$$p_{mn} = \frac{2}{h-b} \int_{-h}^{-b} \zeta_m^i(a, z) \cos k_n(z + h) dz \tag{14}$$

$n = 0, 1, 2, \dots$ with $k_0 = 0$. To obtain the exterior solution, the boundary conditions (6), (7), (9) and (11) are to be satisfied. The incident wave potential ϕ_I^e can be written as

$$\begin{aligned} \phi_I^e &= \frac{gA \cosh \lambda_0(z + h)}{\sigma \cosh \lambda_0 h} e^{i\lambda_0 x} \\ &= \frac{gA \cosh \lambda_0(z + h)}{\sigma \cosh \lambda_0 h} \sum_{m=0}^{\infty} \epsilon_m i^m J_m(\lambda_0 r) \cos m\theta \end{aligned}$$

in which $\epsilon_0 = 1, \epsilon_m = 2, (m \geq 1)$ and λ_0 is the wavenumber. Here σ and λ_0 are related by the dispersion relation $\sigma^2 = g\lambda_0 \tanh \lambda_0 h$ and $J_m(\lambda_0 r)$ is the Bessel function of first kind and order m . Because of the presence of an object we need to consider the scattering of waves. Therefore the appropriate ϕ_S^e satisfying the radiation condition can be constructed from ϕ_I^e and is given by

$$\begin{aligned} \phi_S^e &= \sum_{m=0}^{\infty} \left[\frac{\cosh \lambda_0(z + h)}{\cosh \lambda_0 h} q_{m0} H_m^{(1)}(\lambda_0 r) \right. \\ &\quad \left. + \sum_{j=1}^{\infty} q_{mj} \frac{\cos \lambda_j(z + h)}{\cos \lambda_j h} \frac{K_m(\lambda_j r)}{K_m(\lambda_j a)} \right] \frac{gA}{\sigma} \epsilon_m i^m \cos m\theta \end{aligned}$$

where q_{mj} 's are arbitrary constants. Here $H_m^{(1)}(\lambda_0 r)$ is the Hankel function of first kind of order m and $K_m(\lambda_j r)$ is the modified Bessel function of second kind and order m . Also λ_j satisfies the relation

$$\sigma^2 = -g\lambda_j \tan \lambda_j h$$

$j = 1, 2, 3, \dots$. This equation has infinite number of roots corresponding to $j=1, 2, \dots$. It is to be noted here that we have used the symbol λ_j not to confuse with the symbol $k_n (= \frac{n\pi}{h-b})$ used to represent the eigen values for the interior solution. Thus the velocity potential is given by

$$\begin{aligned} \phi_d^e &= \sum_{m=0}^{\infty} \frac{gA}{\sigma} \epsilon_m i^m \left[\{J_m(\lambda_0 r) + q_{m0} H_m^{(1)}(\lambda_0 r)\} \frac{\cosh \lambda_0(z + h)}{\cosh \lambda_0 h} \right. \\ &\quad \left. + \sum_{j=1}^{\infty} q_{mj} \frac{K_m(\lambda_j r)}{K_m(\lambda_j a)} \frac{\cos \lambda_j(z + h)}{\cos \lambda_j h} \right] \cos m\theta. \tag{15} \end{aligned}$$

The set of functions $\{\cosh \lambda_0(z + h), \cos \lambda_j(z + h)\}, j = 1, 2, \dots$ forms an orthogonal set defined in the interval $-h \leq z \leq 0$ due to the relation $\sigma^2 = g\lambda_0 \tanh \lambda_0 h = -g\lambda_j \tan \lambda_j h$. Thus the orthonormal set can be constructed provided

$$Z_{\lambda_0}(z) = N_{\lambda_0}^{-\frac{1}{2}} \cosh \lambda_0(z + h) \tag{16}$$

$$Z_{\lambda_j}(z) = N_{\lambda_j}^{-\frac{1}{2}} \cos \lambda_j(z + h) \tag{17}$$

where

$$N_{\lambda_0} = \frac{1}{2} \left[1 + \frac{\sinh 2\lambda_0 h}{2\lambda_0 h} \right] \tag{18}$$

$$N_{\lambda_j} = \frac{1}{2} \left[1 + \frac{\sin 2\lambda_j h}{2\lambda_j h} \right]. \tag{19}$$

Thus with these definitions (15) can be written as

$$\begin{aligned} \phi_a^e(r, \theta, z) = & \sum_{m=0}^{\infty} B_m \left[\{ J_m(\lambda_0 r) + q_{m0} \frac{H_m^{(1)}(\lambda_0 r)}{H_m^{(1)}(\lambda_0 a)} \} \frac{Z_{\lambda_0}(z)}{Z_{\lambda_0}(0)} \right. \\ & \left. + \sum_{j=1}^{\infty} q_{mj} \frac{K_m(\lambda_j r)}{K_m(\lambda_j a)} \frac{Z_{\lambda_j}(z)}{Z_{\lambda_j}(0)} \right] \cos m\theta \end{aligned} \tag{20}$$

where $B_m = \frac{q_{m0}}{\sigma} \epsilon_m i^m$. This is valid for $-h \leq z \leq 0, r \geq a$.

For convenience let us define

$$\begin{aligned} \zeta_m^e(r, z) = & \{ J_m(\lambda_0 r) + q_{m0} \frac{H_m^{(1)}(\lambda_0 r)}{H_m^{(1)}(\lambda_0 a)} \} \frac{Z_{\lambda_0}(z)}{Z_{\lambda_0}(0)} \\ & + \sum_{j=1}^{\infty} q_{mj} \frac{K_m(\lambda_j r)}{K_m(\lambda_j a)} \frac{Z_{\lambda_j}(z)}{Z_{\lambda_j}(0)}. \end{aligned}$$

Then we have

$$\phi_a^e(r, \theta, z) = \sum_{m=0}^{\infty} B_m \zeta_m^e(r, z) \cos m\theta.$$

Also we get at $r = a$

$$\zeta_m^e(a, z) = J_m(\lambda_0 a) \frac{Z_{\lambda_0}(z)}{Z_{\lambda_0}(0)} + \sum_{j=0}^{\infty} q_{mj} \frac{Z_{\lambda_j}(z)}{Z_{\lambda_j}(0)}. \tag{21}$$

This equation can easily be recognized as the expansion of $\zeta_m^e(a, z)$ in the orthonormal series defined in $-h \leq z \leq 0$. Therefore the unknown coefficients are obtained as follows :

Multiplying (21) by $\frac{Z_{\lambda_j}(z)}{h}, j = 0, 1, 2, \dots$ and integrating with respect to z from $-h$ to 0 , we obtain (using the orthogonal property)

$$\begin{aligned} \frac{1}{h} \int_{-h}^0 Z_{\lambda_0}(z) \zeta_m^e(a, z) dz &= \frac{J_m(\lambda_0 a) + q_{m0}}{Z_{\lambda_0}(0)} \int_{-h}^0 \frac{Z_{\lambda_0}^2(z)}{h} dz \\ \frac{1}{h} \int_{-h}^0 Z_{\lambda_j}(z) \zeta_m^e(a, z) dz &= \frac{q_{mj}}{Z_{\lambda_j}(0)} \int_{-h}^0 \frac{Z_{\lambda_j}^2(z)}{h} dz. \end{aligned}$$

In view of the orthonormality of the set $\{Z_{\lambda_0}(z), Z_{\lambda_j}(z)\}$ in $-h \leq z \leq 0, \int_{-h}^0 \frac{Z_{\lambda_0}^2(z)}{h} dz = 1$ and $\int_{-h}^0 \frac{Z_{\lambda_j}^2(z)}{h} dz = 1$, we obtain

$$\begin{aligned} q_{m0} &= \frac{Z_{\lambda_0}(0)}{h} \int_{-h}^0 Z_{\lambda_0}(z) \zeta_m^e(a, z) dz - J_m(\lambda_0 a) \\ q_{mj} &= \frac{Z_{\lambda_j}(0)}{h} \int_{-h}^0 Z_{\lambda_j}(z) \zeta_m^e(a, z) dz \end{aligned}$$

where $j = 1, 2, \dots$

3.2 Determination of the unknown coefficients.

To preserve the continuity of the two solutions at the imaginary interface $r = a$, it is required to satisfy

$$\zeta_m^i(a, z) = \zeta_m^e(a, z), \tag{22}$$

$$\frac{\partial \zeta_m^i}{\partial r} \Big|_{r=a} = \frac{\partial \zeta_m^e}{\partial r} \Big|_{r=a} \tag{23}$$

for $-h \leq z \leq -b$. Also body surface condition, namely, $\frac{\partial \phi_a^e}{\partial r} |_{r=a} = 0$, i.e.

$$\frac{\partial \zeta_m^e}{\partial r} |_{r=a} = 0 \tag{24}$$

is to be satisfied. Using the gradient condition (23) valid in $-h \leq z \leq -b$, we have

$$\begin{aligned} \frac{mp_{m0}}{2a} + \sum_{n=1}^{\infty} p_{mn} \frac{k_n I'_m(k_n a)}{I_m(k_n a)} \cos k_n(z+h) \\ = B_m \left[\lambda_0 \left\{ J'_m(\lambda_0 a) + q_{m0} \frac{H_m^{(1)'(\lambda_0 a)} Z_{\lambda_0}(z)}{H_m^{(1)'(\lambda_0 a)} Z_{\lambda_0}(0)} \right\} \right. \\ \left. + \sum_{j=1}^{\infty} q_{mj} \frac{\lambda_j K'_m(\lambda_j a) Z_{\lambda_j}(z)}{K_m(\lambda_j a) Z_{\lambda_j}(0)} \right] \end{aligned} \tag{25}$$

in $-h \leq z \leq -b$. Equation (24) yields

$$\begin{aligned} \lambda_0 \left\{ J'_m(\lambda_0 a) + q_{m0} \frac{H_m^{(1)'(\lambda_0 a)} Z_{\lambda_0}(z)}{H_m^{(1)'(\lambda_0 a)} Z_{\lambda_0}(0)} \right\} \\ + \sum_{j=1}^{\infty} q_{mj} \frac{\lambda_j K'_m(\lambda_j a) Z_{\lambda_j}(z)}{K_m(\lambda_j a) Z_{\lambda_j}(0)} = 0 \end{aligned} \tag{26}$$

in $-b \leq z \leq 0$. Equations (25) and (26) can be rewritten in compact form as follows :

$$\begin{aligned} B_m \mathcal{K}_{m0} Z_{\lambda_0}(z) = B_m \sum_{j=0}^{\infty} q_{mj} \mathcal{H}_{mj} Z_{\lambda_j}(z) + \frac{mp_{m0}}{2} \\ + \sum_{n=1}^{\infty} p_{mn} \mathcal{K}_{mn} \cos k_n(z+h) \end{aligned} \tag{27}$$

in $-h \leq z \leq -b$.

$$B_m \mathcal{K}_{m0} Z_{\lambda_0}(z) = B_m \sum_{j=0}^{\infty} q_{mj} \mathcal{H}_{mj} Z_{\lambda_j}(z) \tag{28}$$

in $-b \leq z \leq 0$.

where

$$\begin{aligned} \mathcal{K}_{m0} &= \frac{\lambda_0 a J'_m(\lambda_0 a)}{Z_{\lambda_0}(0)} \\ \mathcal{K}_{mn} &= \frac{k_n a I'_m(k_n a)}{I_m(k_n a)} \\ \mathcal{H}_{m0} &= -\frac{\lambda_0 a H_m^{(1)'(\lambda_0 a)} Z_{\lambda_0}(0)}{H_m^{(1)'(\lambda_0 a)} Z_{\lambda_0}(0)} \\ \mathcal{H}_{mj} &= -\frac{\lambda_j a K'_m(\lambda_j a)}{K_m(\lambda_j a) Z_{\lambda_j}(0)}. \end{aligned}$$

Now from the functional matching (22), equation (14) yields

$$\begin{aligned} p_{mn} &= \frac{2}{h-b} \int_{-h}^{-b} B_m \zeta_m^e(a, z) \cos k_n(z+h) dz \\ &= \frac{2B_m}{h-b} \left[\frac{J_m(\lambda_0 a)}{Z_{\lambda_0}(0)} \int_{-h}^{-b} Z_{\lambda_0}(z) \cos k_n(z+h) dz \right. \\ &\quad \left. + \sum_{j=0}^{\infty} \frac{q_{mj}}{Z_{\lambda_j}(0)} \int_{-h}^{-b} Z_{\lambda_j}(z) \cos k_n(z+h) dz \right] \end{aligned} \tag{29}$$

$n = 0, 1, 2, \dots$. If we define

$$\mathcal{L}_{n\tau} = \frac{1}{h-b} \int_{-h}^{-b} \frac{Z_\tau(z) \cos k_n(z+h)}{Z_\tau(0)} dz$$

where τ takes the value λ_j , then (29) can be rewritten as

$$p_{mn} = 2B_m [J_m(\lambda_0 a) \mathcal{L}_{n\lambda_0} + \sum_{j=0}^{\infty} q_{mj} \mathcal{L}_{n\lambda_j}]. \tag{30}$$

Now simplifying we get

$$\begin{aligned} \mathcal{L}_{n\lambda_0} &= \frac{1}{(h-b)Z_{\lambda_0}(0)} \int_{-h}^{-b} N_{\lambda_0}^{-\frac{1}{2}} \cosh \lambda_0(z+h) \cos \frac{n\pi(z+h)}{h-b} dz \\ &= \frac{(-1)^n (h-b) \lambda_0 \sinh \lambda_0 (h-b)}{\{(h-b)^2 \lambda_0^2 + n^2 \pi^2\} \cosh \lambda_0 h} \end{aligned}$$

$n = 0, 1, 2, \dots$ and

$$\begin{aligned} \mathcal{L}_{n\lambda_j} &= \frac{1}{(h-b)Z_{\lambda_j}(0)} \int_{-h}^{-b} N_{\lambda_j}^{-\frac{1}{2}} \cos \lambda_j(z+h) \cos \frac{n\pi(z+h)}{h-b} dz \\ &= \frac{1}{2(h-b) \cos \lambda_j h} \left[\frac{\sin((h-b)\lambda_j + n\pi)}{\lambda_j + \frac{n\pi}{h-b}} + \frac{\sin((h-b)\lambda_j - n\pi)}{\lambda_j - \frac{n\pi}{h-b}} \right] \\ &= \frac{(-1)^n (h-b) \lambda_j \sin \lambda_j (h-b)}{\{(h-b)^2 \lambda_j^2 - n^2 \pi^2\} \cos \lambda_j h} \end{aligned}$$

$n = 0, 1, 2, \dots$ and $j = 1, 2, \dots$ Equations (27) and (28) are defined in two domains. The unknowns q_{mj} 's can be determined provided we multiply by $\frac{Z_\tau(z)}{h}$ and integrate with respect to z over the region of validity. This yields

$$\begin{aligned} B_m \mathcal{K}_{m0} \int_{-h}^{-b} \frac{Z_{\lambda_0} Z_\tau}{h} dz &= B_m \sum_{j=0}^{\infty} q_{mj} \mathcal{H}_{mj} \int_{-h}^{-b} \frac{Z_{\lambda_j} Z_\tau}{h} dz + \frac{m p_{m0}}{2h} \int_{-h}^{-b} Z_\tau dz \\ &\quad + \sum_{n=1}^{\infty} \frac{p_{mn} \mathcal{K}_{mn}}{h} \int_{-h}^{-b} Z_\tau \cos k_n(z+h) dz \\ B_m \mathcal{K}_{m0} \int_{-b}^0 \frac{Z_{\lambda_0} Z_\tau}{h} dz &= B_m \sum_{j=0}^{\infty} q_{mj} \mathcal{H}_{mj} \int_{-b}^0 \frac{Z_{\lambda_j} Z_\tau}{h} dz. \end{aligned}$$

Adding these two equations we get

$$\begin{aligned} B_m \mathcal{K}_{m0} \delta_{\lambda_0 \tau} &= B_m \sum_{j=0}^{\infty} q_{mj} \mathcal{H}_{mj} \delta_{\lambda_j \tau} + m p_{m0} \frac{h-b}{2h} Z_\tau(0) \mathcal{L}_{0\tau} \\ &\quad + \sum_{n=1}^{\infty} p_{mn} \mathcal{K}_{mn} \frac{h-b}{h} Z_\tau(0) \mathcal{L}_{n\tau} \end{aligned} \tag{31}$$

where $\delta_{\lambda_j \tau}$ is Kronecker delta. Inserting the expression of p_{mn} , equation (31) can be written as

$$\begin{aligned} \mathcal{K}_{m0} \delta_{\lambda_0 \tau} - J_m(\lambda_0 a) \frac{h-b}{h} Z_\tau(0) \{m \mathcal{L}_{0\lambda_0} \mathcal{L}_{0\tau} + 2 \sum_{n=1}^{\infty} \mathcal{K}_{mn} \mathcal{L}_{n\lambda_0} \mathcal{L}_{n\tau}\} \\ = \sum_{j=0}^{\infty} [\mathcal{H}_{mj} \delta_{\lambda_j \tau} + \frac{h-b}{h} Z_\tau(0) \{m \mathcal{L}_{0\tau} \mathcal{L}_{0\lambda_j} + 2 \sum_{n=1}^{\infty} \mathcal{K}_{mn} \mathcal{L}_{n\tau} \mathcal{L}_{n\lambda_j}\}] q_{mj} \end{aligned}$$

i.e.

$$\sum_{j=0}^{\infty} D_{j\tau} q_{mj} = A_{m\tau} \tag{32}$$

where $D_{j\tau}$ and $A_{m\tau}$'s are given by

$$D_{j\tau} = \mathcal{H}_{mj}\delta_{\lambda_j\tau} + \frac{h-b}{h}Z_\tau(0)\{m\mathcal{L}_{0\tau}\mathcal{L}_{0\lambda_j} + 2\sum_{n=1}^{\infty}\mathcal{K}_{mn}\mathcal{L}_{n\tau}\mathcal{L}_{n\lambda_j}\}$$

$$A_{m\tau} = \mathcal{K}_{m0}\delta_{\lambda_0\tau} - J_m(\lambda_0a)\frac{h-b}{h}Z_\tau(0)\{m\mathcal{L}_{0\tau}\mathcal{L}_{0\lambda_0} + 2\sum_{n=1}^{\infty}\mathcal{K}_{mn}\mathcal{L}_{n\tau}\mathcal{L}_{n\lambda_0}\}.$$

Equation (32) is a complex matrix equation. The unknowns are the coefficients q_{mj} 's. The infinite matrix D should be truncated at certain term to solve (32) numerically. Commercially available matrix solution routines can be used to obtain the solution of the modified equation. Once these coefficients are known the diffraction problem is completely known.

4. RADIATION PROBLEM.

In this case the boundary value problem is

$$\begin{aligned} \nabla^2\phi_r &= 0 \\ g\frac{\partial\phi_r}{\partial z} - \sigma^2\phi_r &= 0 \quad \text{at } z = 0 \\ \frac{\partial\phi_r}{\partial z} &= 0 \quad \text{at } z = -h \\ \frac{\partial\phi_r}{\partial z} &= -i\sigma \quad \text{on } r \leq a \quad \text{and } z = -b \\ \frac{\partial\phi_r}{\partial r} &= 0 \quad \text{at } r = a \quad \text{and } -b \leq z \leq 0 \end{aligned}$$

and the radiation condition

$$\lim_{r \rightarrow \infty} \sqrt{r}\left(\frac{\partial\phi_r}{\partial r} - i\lambda_0\phi_r\right) = 0$$

where λ_0 is the wavenumber. We assume that ϕ_r takes the form

$$\phi_r(r, \theta, z) = \sum_{m=0}^{\infty} \psi_m(r, z) \cos m\theta.$$

Now we obtain the interior solution and exterior solution.

4.1 Interior and exterior solutions.

To obtain the interior solution for ϕ_r , we write $\phi_r^i = \sum_{m=0}^{\infty} \psi_m^i(r, z) \cos m\theta$. Expanding $-i\sigma$ in Fourier cosine series, we can write $-i\sigma = \sum_{m=0}^{\infty} a_m \cos m\theta$ where a_m 's are the Fourier coefficients. Then we have

$$\nabla^2\psi_m^i - \frac{m^2}{r^2}\psi_m^i = 0 \tag{33}$$

$$\frac{\partial\psi_m^i}{\partial z} = 0 \quad \text{at } z = -h \tag{34}$$

$$\frac{\partial\psi_m^i}{\partial z} = a_m \quad \text{on } z = -b \tag{35}$$

where ∇^2 is 2-D Laplacian in r and z . Decomposing ψ_m^i into homogeneous and nonhomogeneous part we write

$$\psi_m^i = \psi_{m_h}^i + \psi_{m_p}^i$$

where $\psi_{m_h}^i$ and $\psi_{m_p}^i$ satisfy the equations (33) and (34). The boundary condition (35) can be decomposed as

$$\frac{\partial\psi_{m_h}^i}{\partial z} = 0 \quad \text{on } z = -b$$

and

$$\frac{\partial \psi_{m,p}^i}{\partial z} = a_m \text{ on } z = -b.$$

For homogeneous part, by method of separation of variables we get

$$\psi_{m,h}^i = \frac{\alpha_{m0}}{2} \left(\frac{r}{a}\right)^m + \sum_{n=1}^{\infty} \frac{\alpha_{mn} I_m(k_n r)}{I_m(k_n a)} \cos k_n(z+h)$$

where α_{mn} 's are constants and $k_n = \frac{n\pi}{h-b}$. To obtain particular solution, we assume

$$\psi_{m,p}^i = A_0 r^2 + B_0 r(z+h) + C_0(z+h)^2$$

where $A_0, B_0,$ and C_0 are constants to be determined from the given conditions. Applying boundary conditions, we get $B_0 = 0, A_0 = \frac{\alpha_m}{2(h-b)},$ and from the governing equation we get $2A_0 + 4C_0 = 0.$ Thus $A_0 = -2C_0 = \frac{\alpha_m}{2(h-b)}.$ Hence the particular solution is

$$\psi_{m,p}^i(r, z) = \frac{\alpha_m}{2(h-b)} \left[(z+h)^2 - \frac{r^2}{2} \right].$$

Hence we get

$$\psi_m^i = \frac{\alpha_{m0}}{2} \left(\frac{r}{a}\right)^m + \sum_{n=1}^{\infty} \frac{\alpha_{mn} I_m(k_n r)}{I_m(k_n a)} \cos k_n(z+h) + \frac{\alpha_m}{2(h-b)} \left[(z+h)^2 - \frac{r^2}{2} \right].$$

At $r = a$ we have

$$\psi_m^i(a, z) = \frac{\alpha_{m0}}{2} + \sum_{n=1}^{\infty} \alpha_{mn} \cos k_n(z+h) + \frac{\alpha_m}{2(h-b)} \left[(z+h)^2 - \frac{a^2}{2} \right]. \tag{36}$$

Multiplying both sides of this equation by $\frac{2}{h-b} \cos k_n(z+h)$ and then integrating both sides from $-h$ to $-b$ (and using the orthogonal property of the functions $\cos k_n(z+h)$), we get an expression for α_{mn} in the following form

$$\alpha_{mn} = \frac{2}{h-b} \int_{-h}^{-b} \psi_m^i(a, z) \cos k_n(z+h) dz - I_{np} \tag{37}$$

where

$$\begin{aligned} I_{0p} &= \frac{\alpha_m}{(h-b)^2} \int_{-h}^{-b} \left[(z+h)^2 - \frac{a^2}{2} \right] dz \\ &= \frac{\alpha_m}{h-b} \left[\frac{(h-b)^2}{3} - \frac{a^2}{2} \right] \\ &= \frac{\alpha_m(h-b)}{6} \left[2 - 3 \left(\frac{a}{h-b} \right)^2 \right] \end{aligned} \tag{38}$$

and

$$\begin{aligned} I_{np} &= \frac{\alpha_m}{(h-b)^2} \int_{-h}^{-b} \left[(z+h)^2 - \frac{a^2}{2} \right] \cos k_n(z+h) dz \\ &= \frac{2(-1)^n \alpha_m (h-b)}{n^2 \pi^2}. \end{aligned} \tag{39}$$

For exterior region, the boundary value problem is

$$\begin{aligned} \nabla^2 \psi_m^e(r, z) - \frac{m^2}{r^2} \psi_m^e(r, z) &= 0 \\ g \frac{\partial \psi_m^e}{\partial z} - \sigma^2 \psi_m^e &= 0 \text{ at } z = 0 \\ \frac{\partial \psi_m^e}{\partial z} &= 0 \text{ at } z = -h \\ \frac{\partial \psi_m^e}{\partial r} &= 0 \text{ at } r = a \text{ and } -b \leq z \leq 0 \end{aligned}$$

where ∇^2 is 2-D Laplacian in r and z . For large argument $H_m^{(1)}$ and K_m satisfy the radiation condition. Applying boundary conditions we arrive at an expression

$$\psi_m^e(r, z) = \frac{\beta_{m0} H_m^{(1)}(\lambda_0 r)}{H_m^{(1)}(\lambda_0 a)} Z_{\lambda_0}(z) + \sum_{j=1}^{\infty} \frac{\beta_{mj} K_m(\lambda_j r)}{K_m(\lambda_j a)} Z_{\lambda_j}(z)$$

where $Z_{\lambda_j}(z)$ and N_{λ_j} , take the forms defined in (16), (17), (18) and (19). $j = 0, 1, 2, \dots$. Now at $r = a$, we have

$$\psi_m^e(a, z) = \sum_{j=0}^{\infty} \beta_{mj} Z_{\lambda_j}(z).$$

Multiplying both sides of this equation by $\frac{Z_{\lambda_j}(z)}{h}$ and then integrating both sides from $-h$ to 0 (and using the orthogonal property of the functions $Z_{\lambda_j}(z)$), we get an expression for β_{mj} in the following form

$$\beta_{mj} = \frac{1}{h} \int_{-h}^0 \psi_m^e(a, z) Z_{\lambda_j}(z) dz$$

$j = 0, 1, 2, \dots$

4.2 Determination of the unknown coefficients.

Matching conditions are

$$\psi_m^i(a, z) = \psi_m^e(a, z), \tag{40}$$

$$\frac{\partial \psi_m^i}{\partial r} \Big|_{r=a} = \frac{\partial \psi_m^e}{\partial r} \Big|_{r=a} \tag{41}$$

for $-h \leq z \leq -b$. Also body surface condition, namely, $\frac{\partial \psi_m^e}{\partial r} \Big|_{r=a} = 0$, i.e.

$$\frac{\partial \psi_m^e}{\partial r} \Big|_{r=a} = 0 \tag{42}$$

is to be satisfied. From the equation (37) and condition (40)

$$\begin{aligned} \alpha_{mn} &= \frac{2}{h-b} \int_{-h}^{-b} \psi_m^i(a, z) \cos k_n(z+h) dz - I_{np} \\ &= \frac{2}{h-b} \int_{-h}^{-b} \psi_m^e(a, z) \cos k_n(z+h) dz - I_{np} \\ &= \frac{2}{h-b} \int_{-h}^{-b} \sum_{j=0}^{\infty} \beta_{mj} Z_{\lambda_j} \cos k_n(z+h) dz - I_{np} \\ &= 2 \sum_{j=0}^{\infty} \beta_{mj} L_{n\lambda_j} - I_{np} \end{aligned} \tag{43}$$

where

$$\begin{aligned} L_{0\lambda_j} &= \frac{1}{h-b} \int_{-h}^{-b} Z_{\lambda_j} dz \\ L_{n\lambda_j} &= \frac{1}{h-b} \int_{-h}^{-b} Z_{\lambda_j} \cos k_n(z+h) dz. \end{aligned}$$

Also

$$\begin{aligned} L_{n\lambda_0} &= \frac{1}{h-b} \int_{-h}^{-b} Z_{\lambda_0} \cos k_n(z+h) dz \\ &= \frac{N_{\lambda_0}^{-\frac{1}{2}}}{h-b} \int_0^{h-b} \cosh \lambda_0 u \cos k_n u du \\ &= \frac{(-1)^n N_{\lambda_0}^{-\frac{1}{2}} (h-b) \lambda_0 \sinh \lambda_0 (h-b)}{(h-b)^2 \lambda_0^2 + n^2 \pi^2} \end{aligned} \tag{44}$$

and

$$\begin{aligned}
 L_{n\lambda_j} &= \frac{1}{h-b} \int_{-h}^{-b} Z_{\lambda_j} \cos k_n(z+h) dz \\
 &= \frac{N_{\lambda_j}^{-\frac{1}{2}}}{h-b} \int_0^{h-b} \cos \lambda_j u \cos k_n u du \\
 &= \frac{(-1)^n N_{\lambda_j}^{-\frac{1}{2}} (h-b) \lambda_j \sin \lambda_j (h-b)}{(h-b)^2 \lambda_j^2 - n^2 \pi^2}
 \end{aligned} \tag{45}$$

$n = 0, 1, 2, \dots$, and $j = 1, 2, \dots$

Now from the gradient condition (41) and body surface condition (42), we have

$$G_{m0} + \frac{m\alpha_{m0}}{2} = \sum_{n=1}^{\infty} \alpha_{mn} G_{mn} \cos k_n(z+h) + \sum_{j=0}^{\infty} \beta_{mj} \mathcal{G}_{mj} Z_{\lambda_j}(z) \tag{46}$$

for $-h \leq z \leq -b$,

$$\sum_{j=0}^{\infty} \beta_{mj} \mathcal{G}_{mj} Z_{\lambda_j}(z) = 0 \quad \textit{for} \quad -b \leq z \leq 0 \tag{47}$$

where

$$\begin{aligned}
 G_{m0} &= -\frac{a_m a^2}{2(h-b)} \\
 G_{mn} &= -\frac{k_n a I'_m(k_n a)}{I_m(k_n a)} \\
 \mathcal{G}_{m0} &= \frac{\lambda_0 a H_m^{(1)'}(\lambda_0 a)}{H_m^{(1)}(\lambda_0 a)} \\
 \mathcal{G}_{mn} &= \frac{\lambda_n a K_m'(\lambda_n a)}{K_m(\lambda_n a)}.
 \end{aligned}$$

Now multiplying the equations (46) and (47) by $\frac{Z_{\lambda_l}(z)}{h}$, $l = 0, 1, 2, \dots$ and integrating in the regions of validity and adding them we get

$$(G_{m0} + \frac{m\alpha_{m0}}{2}) L_{0\lambda_l} = \sum_{n=1}^{\infty} \alpha_{mn} G_{mn} L_{n\lambda_l} + \sum_{j=0}^{\infty} \frac{h}{h-b} \beta_{mj} \mathcal{G}_{mj} \delta_{\lambda_j \lambda_l}.$$

Now substituting the values of α_{mn} we get a system of equations

$$\sum_{j=0}^{\infty} E_{lj} \beta_{mj} = X_{ml} \tag{48}$$

where

$$\begin{aligned}
 E_{lj} &= -m L_{0\lambda_l} L_{0\lambda_j} + \frac{h}{h-b} \mathcal{G}_{mj} \delta_{\lambda_j \lambda_l} + 2 \sum_{n=1}^{\infty} G_{mn} L_{n\lambda_l} L_{n\lambda_j} \\
 X_{ml} &= G_{m0} L_{0\lambda_l} - \frac{m I_{0p} L_{0\lambda_l}}{2} + \sum_{n=1}^{\infty} I_{np} G_{mn} L_{n\lambda_l}
 \end{aligned}$$

$l = 0, 1, 2, \dots$

5. EVALUATION OF THE FORCES AND MOMENTS.

The horizontal and the vertical forces on the cylinder are calculated from the pressure obtained from Bernoulli's equation as mentioned in (1), (2), (3) and (4). Since for the radiation due to heave $m = 0$, contribution to f_x and m_s will be from ϕ_d only. Thus

$$\begin{aligned}
 f_x &= -i\rho\sigma a \int_{\theta=0}^{2\pi} \int_{z=-b}^0 \phi_d^e(a, \theta, z) \cos \theta dz d\theta \\
 &= -\rho g a A \int_{z=-b}^0 \int_{\theta=0}^{2\pi} \left[\sum_{m=0}^{\infty} i^{m+1} \epsilon_m \left\{ J_m(\lambda_0 a) \frac{Z_{\lambda_0}(z)}{Z_{\lambda_0}(0)} + \sum_{j=0}^{\infty} q_{mj} \frac{Z_{\lambda_j}(z)}{Z_{\lambda_j}(0)} \right\} \cos m\theta \right] \cos \theta d\theta dz \\
 &= 2\rho g a A \int_{z=-b}^0 \int_{\theta=0}^{2\pi} \left\{ J_1(\lambda_0 a) \frac{Z_{\lambda_0}(z)}{Z_{\lambda_0}(0)} + \sum_{j=0}^{\infty} q_{1j} \frac{Z_{\lambda_j}(z)}{Z_{\lambda_j}(0)} \right\} \cos^2 \theta d\theta dz \\
 &= 2\pi \rho g a^2 A \left[\{J_1(\lambda_0 a) + q_{10}\} \frac{\sinh \lambda_0 h - \sinh \lambda_0 (h-b)}{\lambda_0 a \cosh \lambda_0 h} + \sum_{j=1}^{\infty} q_{1j} \frac{\sin \lambda_j h - \sin \lambda_j (h-b)}{\lambda_j a \cos \lambda_j h} \right].
 \end{aligned}$$

Thus

$$\frac{f_z}{D} = 2\{[J_1(\lambda_0 a) + q_{10}] \frac{\sinh \lambda_0 h - \sinh \lambda_0 (h - b)}{\lambda_0 a \cosh \lambda_0 h} + \sum_{j=1}^{\infty} q_{1j} \frac{\sin \lambda_j h - \sin \lambda_j (h - b)}{\lambda_j a \cos \lambda_j h}\} \tag{49}$$

where

$$D = \pi \rho g a^2 A.$$

The vertical force component f_z can be written as

$$f_z = f_{zd} + f_{zr}$$

where f_{zd} and f_{zr} are given by

$$\begin{aligned} f_{zd} &= i\rho\sigma \int_{\theta=0}^{2\pi} \int_0^a \phi_d^i(r, \theta, -b) r dr d\theta \\ &= i\rho\sigma \int_{\theta=0}^{2\pi} \int_{r=0}^a \left[\frac{p_{00}}{2} + \sum_{n=1}^{\infty} p_{0n} \frac{I_0(k_n r)}{I_0(k_n a)} \cos k_n (h - b) \right] r dr d\theta \\ &= 2\pi i\rho\sigma \left[\frac{a^2 p_{00}}{4} + \sum_{n=1}^{\infty} \frac{(-1)^n p_{0n}}{I_0(k_n a)} \int_0^a r I_0(k_n r) dr \right] \\ &= 2\pi i\rho\sigma a^2 \left[\frac{p_{00}}{4} + \sum_{n=1}^{\infty} \frac{(-1)^n p_{0n} I_1(k_n a)}{k_n a I_0(k_n a)} \right] \\ &= 4\pi i\rho a^2 A \left[\frac{1}{4} \{J_0(\lambda_0 a) \mathcal{L}_{0\lambda_0} + \sum_{j=0}^{\infty} q_{0j} \mathcal{L}_{0\lambda_j}\} \right. \\ &\quad \left. + \sum_{n=1}^{\infty} \frac{(-1)^n I_1(k_n a)}{k_n a I_0(k_n a)} \{J_0(\lambda_0 a) \mathcal{L}_{n\lambda_0} + \sum_{j=0}^{\infty} q_{0j} \mathcal{L}_{n\lambda_j}\} \right] \end{aligned}$$

and

$$\begin{aligned} f_{zr} &= i\rho\sigma \hat{\xi} \int_{\theta=0}^{2\pi} \int_{r=0}^a \phi_r^i(r, \theta, -b) r dr d\theta \\ &= 2\pi i\rho\sigma \hat{\xi} \left[a_0 (h - b) \left(\frac{a^2}{4} - \frac{1}{16} \frac{a^4}{(h - b)^2} \right) + \frac{a^2 \alpha_{00}}{4} + \sum_{n=1}^{\infty} \frac{(-1)^n a \alpha_{0n} I_1(k_n a)}{k_n I_0(k_n a)} \right] \\ &= i\pi a^2 \rho \sigma \hat{\xi} \left[a_0 (h - b) \left(\frac{1}{2} - \frac{1}{8} \left(\frac{a}{h - b} \right)^2 \right) + \sum_{j=0}^{\infty} \beta_{0j} L_{0\lambda_j} - \frac{I_{0p}}{2} \right. \\ &\quad \left. + \frac{2}{\pi} \frac{h - b}{a} \sum_{n=1}^{\infty} \frac{(-1)^n I_1(k_n a)}{n I_0(k_n a)} \left\{ 2 \sum_{j=0}^{\infty} \beta_{0j} L_{n\lambda_j} - I_{np} \right\} \right] \\ &= \pi a^2 (h - b) \rho \sigma^2 \hat{\xi} \left[\frac{1}{3} + \frac{1}{8} \left(\frac{a}{h - b} \right)^2 + \sum_{j=0}^{\infty} \gamma_{0j} L_{0\lambda_j} \right. \\ &\quad \left. + \frac{4}{\pi} \frac{h - b}{a} \sum_{n=1}^{\infty} \frac{(-1)^n I_1(k_n a)}{n I_0(k_n a)} \left\{ \sum_{j=0}^{\infty} \gamma_{0j} L_{n\lambda_j} - \frac{(-1)^n}{n^2 \pi^2} \right\} \right] \end{aligned}$$

where $\gamma_{0j} = \frac{\beta_{0j}}{a_0(h-b)}$ and $a_0 = -i\sigma$. Thus we have

$$\begin{aligned} \frac{f_z}{D} &= 4i \left[\frac{1}{4} \{J_0(\lambda_0 a) \mathcal{L}_{0\lambda_0} + \sum_{j=0}^{\infty} q_{0j} \mathcal{L}_{0\lambda_j}\} \right. \\ &\quad \left. + \sum_{n=1}^{\infty} \frac{(-1)^n I_1(k_n a)}{k_n a I_0(k_n a)} \{J_0(\lambda_0 a) \mathcal{L}_{n\lambda_0} + \sum_{j=0}^{\infty} q_{0j} \mathcal{L}_{n\lambda_j}\} \right] \\ &\quad + \lambda_0 (h - b) \tanh \lambda_0 h \frac{\hat{\xi}}{A} \left[\frac{1}{3} + \frac{1}{8} \left(\frac{a}{h - b} \right)^2 + \sum_{j=0}^{\infty} \gamma_{0j} L_{0\lambda_j} \right. \\ &\quad \left. + \frac{4}{\pi} \frac{h - b}{a} \sum_{n=1}^{\infty} \frac{(-1)^n I_1(k_n a)}{n I_0(k_n a)} \left\{ \sum_{j=0}^{\infty} \gamma_{0j} L_{n\lambda_j} - \frac{(-1)^n}{n^2 \pi^2} \right\} \right]. \tag{50} \end{aligned}$$

Now we compute the moment on the side of the body about sea-bottom

$$\begin{aligned}
 m_s &= -i\rho\sigma a \int_{\theta=0}^{2\pi} \int_{-b}^0 (z+h)\phi_a^e(a, \theta, z) \cos \theta dz d\theta \\
 &= 2\pi\rho g a A \int_{-b}^0 (z+h) \left[J_1(\lambda_0 a) \frac{Z_{\lambda_0}(z)}{Z_{\lambda_0}(0)} + \sum_{j=1}^{\infty} q_{1j} \frac{Z_{\lambda_j}(z)}{Z_{\lambda_j}(0)} \right] dz \\
 &= 2\pi\rho g a^3 A \left[\frac{J_1(\lambda_0 a) + q_{10}}{\cosh \lambda_0 h} \left\{ \frac{\lambda_0 h \sinh \lambda_0 h + \cosh \lambda_0 (h-b)}{(\lambda_0 a)^2} \right. \right. \\
 &\quad \left. \left. - \frac{\cosh \lambda_0 h + \lambda_0 (h-b) \sinh \lambda_0 (h-b)}{(\lambda_0 a)^2} \right\} \right. \\
 &\quad \left. + \sum_{j=1}^{\infty} \frac{q_{1j}}{\cos \lambda_j h} \left\{ \frac{\cos \lambda_j h - \cos \lambda_j (h-b)}{(\lambda_j a)^2} \right. \right. \\
 &\quad \left. \left. + \frac{\lambda_j h \sin \lambda_j h - \lambda_j (h-b) \sin \lambda_j (h-b)}{(\lambda_j a)^2} \right\} \right].
 \end{aligned}$$

Hence we have

$$\begin{aligned}
 \frac{m_s}{Da} &= 2 \left[\frac{J_1(\lambda_0 a) + q_{10}}{\cosh \lambda_0 h} \left\{ \frac{\lambda_0 h \sinh \lambda_0 h + \cosh \lambda_0 (h-b)}{(\lambda_0 a)^2} \right. \right. \\
 &\quad \left. \left. - \frac{\cosh \lambda_0 h + \lambda_0 (h-b) \sinh \lambda_0 (h-b)}{(\lambda_0 a)^2} \right\} \right. \\
 &\quad \left. + \sum_{j=1}^{\infty} \frac{q_{1j}}{\cos \lambda_j h} \left\{ \frac{\cos \lambda_j h - \cos \lambda_j (h-b)}{(\lambda_j a)^2} \right. \right. \\
 &\quad \left. \left. + \frac{\lambda_j h \sin \lambda_j h - \lambda_j (h-b) \sin \lambda_j (h-b)}{(\lambda_j a)^2} \right\} \right]. \tag{51}
 \end{aligned}$$

Moment m_b at the bottom of the body about z-axis can be as

$$m_b = m_{bd} + m_{br}$$

where m_{bd} and m_{br} are given by

$$\begin{aligned}
 m_{bd} &= i\rho\sigma \int_{\theta=0}^{2\pi} \int_0^a \phi_a^i(r, \theta, -b) r^2 dr d\theta \\
 &= i\rho\sigma \int_0^{2\pi} \int_0^a \sum_{m=0}^{\infty} \left[\frac{p_{m0}}{2} \left(\frac{r}{a}\right)^m + \sum_{n=1}^{\infty} p_{mn} \cos k_n (h-b) \frac{I_m(k_n r)}{I_m(k_n a)} \right] r^2 \cos m\theta dr d\theta \\
 &= 2\pi i\rho\sigma a^3 \left[\frac{p_{00}}{6} + \sum_{n=1}^{\infty} \frac{(-1)^n p_{0n}}{(k_n a)^3 I_0(k_n a)} \{ (k_n a)^2 I_1(k_n a) - k_n a I_0(k_n a) + \int_0^{k_n a} I_0(u) du \} \right] \\
 &= 2\pi i\rho\sigma a^3 \left[\frac{p_{00}}{6} + \sum_{n=1}^{\infty} \frac{(-1)^n p_{0n}}{(k_n a)^2 I_0(k_n a)} \{ k_n a I_1(k_n a) - I_0(k_n a) + \sum_{k=0}^{\infty} \frac{(k_n a)^{2k}}{(2k+1)2^{2k}(k!)^2} \} \right]
 \end{aligned}$$

and

$$\begin{aligned}
 m_{br} &= i\rho\sigma \int_{\theta=0}^{2\pi} \int_0^a \hat{\xi} \phi_r^i(r, \theta, -b) r^2 dr d\theta \\
 &= 2\pi i\rho\sigma \hat{\xi} \int_0^a \left[\frac{\alpha_{00}}{2} + \sum_{n=1}^{\infty} \frac{(-1)^n \alpha_{0n} I_0(k_n r)}{I_0(k_n a)} + \frac{a_0}{2(h-b)} \{ (h-b)^2 - \frac{r^2}{2} \} \right] r^2 dr \\
 &= 2\pi\rho\sigma^2 a^3 (h-b) \hat{\xi} \left[\frac{1}{60} \{ 10 - 3\left(\frac{a}{h-b}\right)^2 \} + \frac{2 \sum_{j=0}^{\infty} \beta_{0j} L_{0\lambda_j} - I_{0p}}{6a_0(h-b)} \right. \\
 &\quad \left. + \sum_{n=1}^{\infty} \frac{(-1)^n (2 \sum_{j=0}^{\infty} \beta_{0j} L_{n\lambda_j} - I_{np})}{(k_n a)^2 a_0 (h-b) I_0(k_n a)} \{ k_n a I_1(k_n a) - I_0(k_n a) + \sum_{k=0}^{\infty} \frac{(k_n a)^{2k}}{(2k+1)2^{2k}(k!)^2} \} \right] \\
 &= 4\pi a^3 \rho g \lambda_0 (h-b) \tanh \lambda_0 h \hat{\xi} \left[\frac{1}{18} + \frac{1}{60} \left(\frac{a}{h-b}\right)^2 + \frac{1}{6} \sum_{j=0}^{\infty} \gamma_{0j} L_{0\lambda_j} \right. \\
 &\quad \left. + \sum_{n=1}^{\infty} \frac{(-1)^n (\sum_{j=0}^{\infty} \gamma_{0j} L_{n\lambda_j} - \frac{(-1)^n}{6n^2\pi^2})}{(k_n a)^2 I_0(k_n a)} \{ k_n a I_1(k_n a) - I_0(k_n a) + \sum_{k=0}^{\infty} \frac{(k_n a)^{2k}}{(2k+1)2^{2k}(k!)^2} \} \right]
 \end{aligned}$$

where $\gamma_{0j} = \frac{\beta_{0j}}{a_0(h-b)}$. Thus we get

$$\begin{aligned}
 \frac{m_b}{Da} &= 4i\left\{\frac{1}{6}\{J_0(\lambda_0 a)\mathcal{L}_{0\lambda_0} + \sum_{j=0}^{\infty} q_{0j}\mathcal{L}_{0\lambda_j}\} + \sum_{n=1}^{\infty} \frac{(-1)^n}{(k_n a)^2 I_0(k_n a)} \{J_0(\lambda_0 a)\mathcal{L}_{n\lambda_0} + \sum_{j=0}^{\infty} q_{0j}\mathcal{L}_{n\lambda_j}\}\right. \\
 &\quad \times \{k_n a I_1(k_n a) - I_0(k_n a) + \sum_{k=0}^{\infty} \frac{(k_n a)^{2k}}{(2k+1)2^{2k}(k!)^2}\} + 4\lambda_0(h-b) \tanh \lambda_0 h \frac{\hat{\xi}}{A} \left[\frac{1}{18}\right. \\
 &\quad \left. + \frac{1}{60}\left(\frac{a}{h-b}\right)^2 + \frac{1}{6} \sum_{j=0}^{\infty} \gamma_{0j} L_{0\lambda_j} + \sum_{n=1}^{\infty} \frac{(-1)^n (\sum_{j=0}^{\infty} \gamma_{0j} L_{n\lambda_j} - \frac{(-1)^n}{6n^2\pi^2})}{(k_n a)^2 I_0(k_n a)}\right. \\
 &\quad \left. \times \{k_n a I_1(k_n a) - I_0(k_n a) + \sum_{k=0}^{\infty} \frac{(k_n a)^{2k}}{(2k+1)2^{2k}(k!)^2}\}\right\}. \tag{52}
 \end{aligned}$$

6. DETERMINATION OF THE HEAVE AMPLITUDE AND INCIDENT WAVE AMPLITUDE RATION.

From the equation of heave motion we get

$$M \frac{\partial^2 \xi}{\partial t^2} = F_r + F_e^z + F_h$$

where M is the mass of displaced fluid, F_r is the radiated force, F_e^z is the exciting force in z-direction and F_h is the hydrostatic force. Thus we have

$$M \frac{\partial^2 \xi}{\partial t^2} = -\mu \frac{\partial^2 \xi}{\partial t^2} - \nu \frac{\partial \xi}{\partial t} + F_e^z - \kappa \xi$$

computed from hydrostatic force. Now the equation of motion in complex form becomes

$$(M + \mu)(-i\sigma)^2 \hat{\xi} + (-i\sigma)\nu \hat{\xi} + \kappa \hat{\xi} = f_{zd}.$$

This yields

$$\hat{\xi} = \frac{f_{zd}}{\kappa - \sigma^2(M + \mu + i\frac{\nu}{\sigma})}.$$

Since the radiated force F_r can be decomposed into components in phase with acceleration and the velocity of the cylinder in the following way

$$F_r = Re[f_r e^{-i\sigma t}] = -(\mu \frac{\partial^2 \xi}{\partial t^2} + \nu \frac{\partial \xi}{\partial t}),$$

we can write $f_r = \sigma^2 \hat{\xi}(\mu + i\frac{\nu}{\sigma})$. Thus we have

$$\frac{\mu + i\frac{\nu}{\sigma}}{S} = c_r^n$$

where

$$\begin{aligned}
 c_r^n &= i\frac{1}{3} + \frac{1}{8}\left(\frac{a}{h-b}\right)^2 + \sum_{j=0}^{\infty} \gamma_{0j} L_{0\lambda_j} \\
 &\quad + \frac{4}{\pi} \frac{h-b}{a} \sum_{n=1}^{\infty} \frac{(-1)^n I_1(k_n a)}{n I_0(k_n a)} \left\{ \sum_{j=0}^{\infty} \gamma_{0j} L_{n\lambda_j} - \frac{(-1)^n}{n^2 \pi^2} \right\}
 \end{aligned}$$

and $S = \pi a^2(h-b)\rho$. Thus we get

$$\frac{\hat{\xi}}{A} = \frac{c_e^z}{1 - \lambda_0 \tanh \lambda_0 h \{b + (h-b)c_r^n\}} \tag{53}$$

where

$$c_e^z = \frac{f_{zd}}{D}.$$

7. NUMERICAL RESULTS.

The complex matrix equation (32) is to be solved in order to determine the unknown coeffi-

icients q_{mj} for $m = 0$ and $m = 1$. To compute the horizontal exciting force, f_{xd} , we need to solve the equation (32) for $m = 1$ and the vertical exciting force, f_{zd} , is evaluated using the solution of this equation when $m = 0$. This infinite order system is made finite to solve it numerically by writing as

$$\sum_{j=0}^{N_p} \mathcal{D}_{j\tau} q_{mj} = \mathcal{A}_{m\tau} \tag{54}$$

where $\mathcal{D}_{j\tau}$ and $\mathcal{A}_{m\tau}$'s are given by

$$\begin{aligned} \mathcal{D}_{j\tau} &= \mathcal{H}_{mj} \delta_{\lambda_j \tau} + \frac{h-b}{h} Z_\tau(0) \{ m \mathcal{L}_{0\tau} \mathcal{L}_{0\lambda_j} + 2 \sum_{n=1}^{N_n} K_{mn} \mathcal{L}_{n\tau} \mathcal{L}_{n\lambda_j} \} \\ \mathcal{A}_{m\tau} &= K_{m0} \delta_{\lambda_0 \tau} - J_0(\lambda_0 a) \frac{h-b}{h} Z_\tau(0) \{ m \mathcal{L}_{0\tau} \mathcal{L}_{0\lambda_0} + 2 \sum_{n=1}^{N_n} K_{mn} \mathcal{L}_{n\tau} \mathcal{L}_{n\lambda_0} \} \end{aligned}$$

$\tau = 0, 1, \dots, N_p$ and $j = 0, 1, \dots, N_p$.

The complex matrix equation (48) is truncated as following

$$\sum_{j=0}^{N_p} \mathcal{E}_{ij} \gamma_{0j} = \mathcal{X}_{0l} \tag{55}$$

where \mathcal{E}_{ij} and \mathcal{X}_{0l} 's are given by

$$\begin{aligned} \mathcal{E}_{ij} &= \frac{h}{h-b} \mathcal{G}_{0j} \delta_{\lambda_j \lambda_l} + 2 \sum_{n=1}^{N_n} G_{0n} L_{n\lambda_l} L_{n\lambda_j} \\ \mathcal{X}_{0l} &= g_{00} L_{0\lambda_l} + \sum_{n=1}^{N_n} \mathcal{I}_{np} G_{0n} L_{n\lambda_l} \end{aligned}$$

where

$$\begin{aligned} g_{00} &= -\frac{a^2}{2(h-b)^2} \\ \mathcal{I}_{np} &= \frac{2(-1)^n}{n^2 \pi^2} \end{aligned}$$

$l = 0, 1, \dots, N_p$ and $j = 0, 1, \dots, N_p$.

Thus \mathcal{D} and \mathcal{E} are square matrices of order $(N_p + 1)$ and $\mathcal{A}_{0\tau}$, $\mathcal{A}_{1\tau}$ and \mathcal{X}_{0l} are vectors of length $(N_p + 1)$. These systems of equations are solved by using a complex matrix inversion subroutine available in IMSL at TUNS cyber system. We select $N_p = 8$ and $N_n = 12$ which are seemed to be good enough for the convergence of the solutions. Also we take $N_k = 20$. Once q_{0j} , q_{1j} and γ_{0j} 's are known, we can compute the wave loads using the expressions (53), (49), (50), (51) and (52) by truncating the infinite series for the indices j , n , and k at N_p , N_n , and N_k respectively. The heave amplitude and the incident wave amplitude ratios are depicted in Fig. 2 as function of $\lambda_0 a$. Non-dimensional x-component of the horizontal force is depicted in Fig. 3. Fig. 4 presents the non-dimensional vertical force. The non-dimensional moment acting on the side of the cylinder is shown in Fig. 5. Fig. 6 depicts the non-dimensional moment acting at the bottom of the cylinder. Different depth to radius ratios considered here are 2.00 and 3.00 with a combination of draft to radius ratios 0.75, 1.00, and 1.25.

8. CONCLUSIONS.

The wave loads for a vertical circular cylinder heaving in finite depth water in the presence of an incident wave have been computed in this paper. Analytical solutions for the total velocity potential is obtained by dividing the whole boundary value problem into two problems, namely, diffraction problem of an incident wave acting on the fixed cylinder and radiation problem of the

cylinder forced to oscillate in otherwise still water. Mathematical solutions for the boundary value problems are obtained in two physical regions, namely, interior region and exterior region. The exciting force components are obtained by solving the diffraction problem and the added mass and damping coefficients are obtained by solving the radiation problem. Then heave response induced by wave excitation is determined from the equation of motion of the floating cylinder. Using Bernoulli's equation, pressure is computed which is used to compute the wave loads. Results for different depth to radius and draft to radius ratios are presented in various figures.

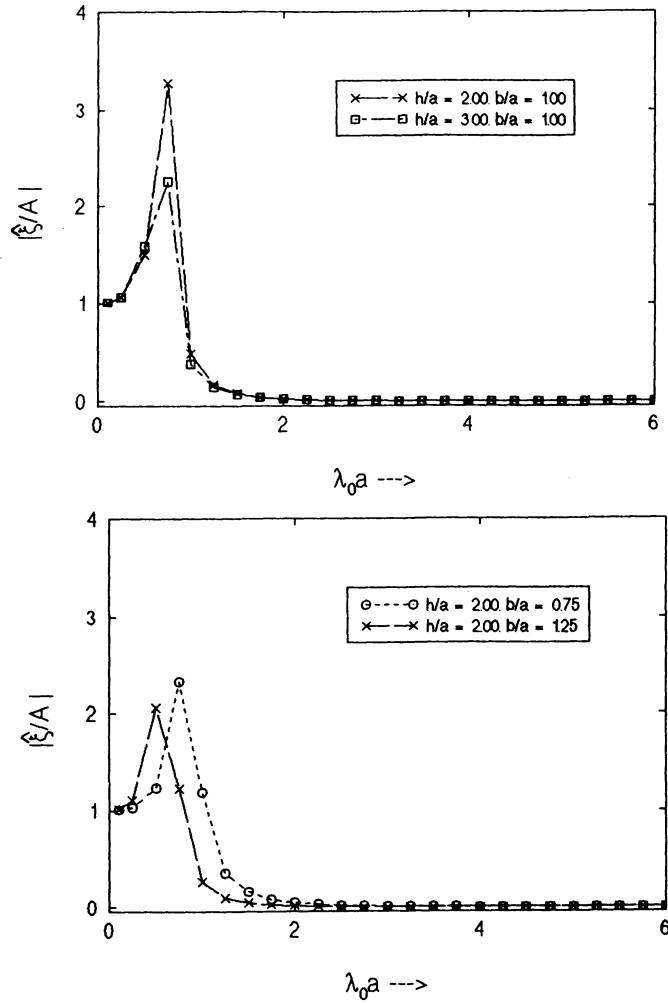

FIGURE 2. Amplitude of $\dot{\xi}/A$.

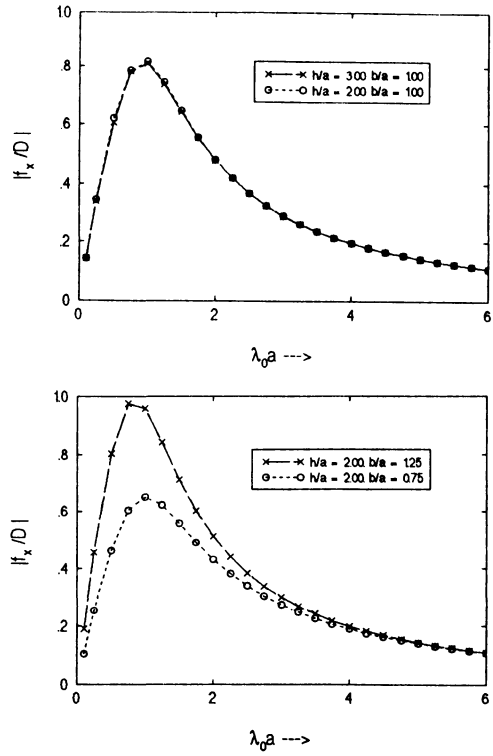

FIGURE 3. Non-dimensional horizontal force.

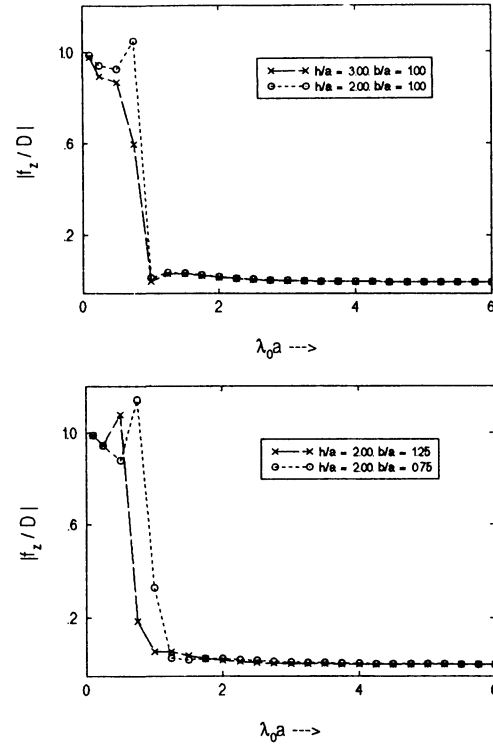

FIGURE 4. Non-dimensional vertical force.

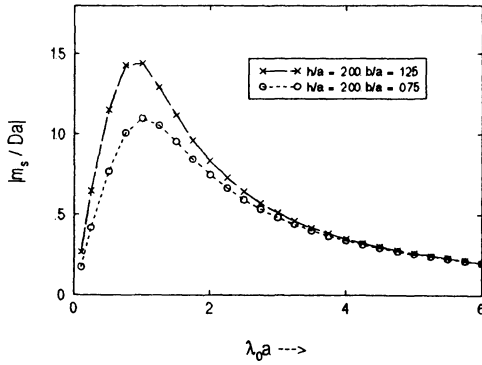
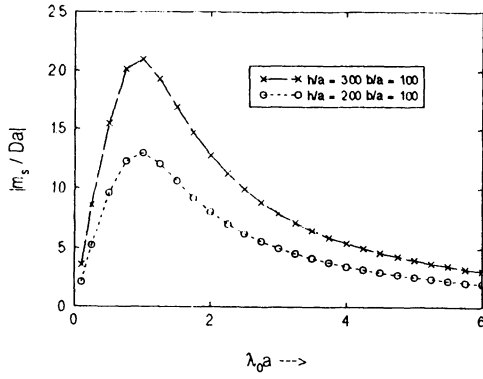

FIGURE 5. Non-dimensional moment, $\frac{m_s}{Da}$.

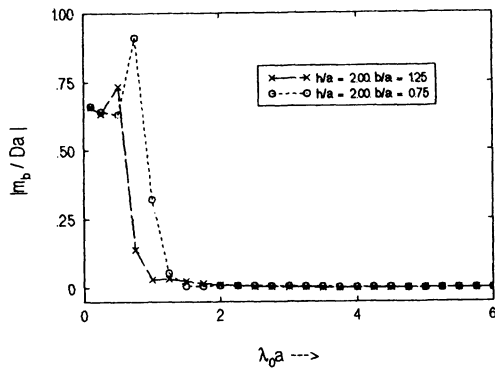
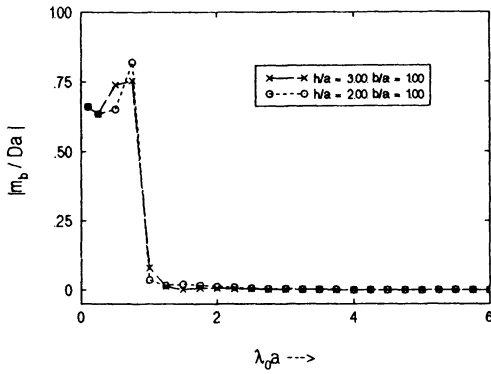

FIGURE 6. Non-dimensional moment, $\frac{m_b}{Da}$.

REFERENCES

1. BAI, K. J., The added mass of two-dimensional cylinders heaving in water of finite depth, J. Fluid Mech., 81 (1977), 85-105.
2. BLACK, J. L., MEI, C. C. and BRAY, C. G., Radiation and scattering of water waves by rigid bodies, J. Fluid Mech., 46 (1971), 151-164.
3. GARRETT, C.J.R., Wave forces on a circular dock, J. Fluid Mech., 46 (1971), 129-139.
4. GARRISON, C. J., Hydrodynamics of Large Objects in the Sea; Part I: Hydrodynamic Analysis, Journal of Hydronautics, 8, 1 (1974), 5-12.
5. GARRISON, C. J., Hydrodynamics of Large Objects in the Sea; Part II: Motion of Free-Floating Bodies, Journal of Hydronautics, 9, 2 (1975), 58-63.
6. ISAACSON, M., Wave forces on compound cylinders, Proc. Civil Engineering in the Oceans IV, ASCE, San Francisco, I (1979), 518-530.
7. MCIVER, P. and LINTON, C. M., The added mass of bodies heaving at low frequency in water of finite depth, Applied Ocean Research, 13, 1 (1991), 12-17.
8. MILES, J. W. and GILBERT, J. F., Scattering of gravity waves by a circular dock, J. Fluid Mech., 34 (1968), 783-793.
9. SABUNCU, T. and CALISAL, S., Hydrodynamic coefficients for a vertical circular cylinders at finite depth, Ocean Engng., 8 (1981), 25-63.
10. WILLIAMS, A. N. and DEMIRBILEK, Z., Hydrodynamic interactions in floating cylinder arrays -I. Wave scattering, Ocean Engng., 15, 6 (1988), 549-583.
11. WILLIAMS, A. N. and ABUL-AZM, A. G., Hydrodynamic interactions in floating cylinder arrays -II. Wave radiation, Ocean Engng., 16, 3 (1989), 217-263.
12. YEUNG, R. W., Added mass and damping of a vertical cylinder in finite-depth water, Applied Ocean Research 3, 3 (1981), 119-133.

Special Issue on Singular Boundary Value Problems for Ordinary Differential Equations

Call for Papers

The purpose of this special issue is to study singular boundary value problems arising in differential equations and dynamical systems. Survey articles dealing with interactions between different fields, applications, and approaches of boundary value problems and singular problems are welcome.

This Special Issue will focus on any type of singularities that appear in the study of boundary value problems. It includes:

- Theory and methods
- Mathematical Models
- Engineering applications
- Biological applications
- Medical Applications
- Finance applications
- Numerical and simulation applications

Before submission authors should carefully read over the journal's Author Guidelines, which are located at <http://www.hindawi.com/journals/bvp/guidelines.html>. Authors should follow the Boundary Value Problems manuscript format described at the journal site <http://www.hindawi.com/journals/bvp/>. Articles published in this Special Issue shall be subject to a reduced Article Processing Charge of €200 per article. Prospective authors should submit an electronic copy of their complete manuscript through the journal Manuscript Tracking System at <http://mts.hindawi.com/> according to the following timetable:

Manuscript Due	May 1, 2009
First Round of Reviews	August 1, 2009
Publication Date	November 1, 2009

Lead Guest Editor

Juan J. Nieto, Departamento de Análisis Matemático,
Facultad de Matemáticas, Universidad de Santiago de

Compostela, Santiago de Compostela 15782, Spain;
juanjose.nieto.roig@usc.es

Guest Editor

Donal O'Regan, Department of Mathematics, National
University of Ireland, Galway, Ireland;
donal.oregan@nuigalway.ie