

Study on Maximum Flow Rates and Sizing Method of Overflow Pipes in Water Tanks

**X.W. Wang (1), F. Kiya (2), K. Maejima (3), S. Yanagimura (4),
C. Yoneda (5)**

(1) SUGA Co., Ltd., Research and Development Center, syo-o@suga-kogyo.co.jp

(2) Kanagawa University

(3) P.T. Morimura & Associates, Ltd.

(4) SUGA Co., Ltd., Research and Development Center

(5) SUGA Co., Ltd., Research and Development Center

Abstract

When examining the standard of the air-gap in open tanks with overflow pipes, it is necessary to determine the height of the highest water level and maximum capacity of overflow pipe in tanks. However, it is not cleared not only to determine the height and the capacity, but also to decide the size of overflow pipe. Therefore, the experimental study was carried out for the purpose to obtain them.

In this paper, it was reported the experiment result concerning the FRP water tank with overflow pipe of inside diameters 50 mm and 100 mm. As a result, empirical formulae of the height by incoming flow rates and inside diameters, and the maximum flow rate of overflow pipes are shown. Moreover, methods to decide the size of overflow pipes are proposed.

Keywords

Experiment, Air-Gap, Water Level Change, Overflow, Maximum Flow Rate of Overflow Pipe, Sizing Method of Overflow Pipe

1. Introduction

Setting the air-gap to prevent the back-siphonage is a simple and reliable method. There are the standard of the air-gap in each country. In Japan, a study on small size pipes by diameters 9 mm to 30 mm by Shinohara et al. had been carried out, and the standard published in SHASE-S206-2000 which is based on the result is the standard of SHASE (The Society of Heating Air-conditioning and Sanitary Engineering of Japan). Experimental grounds on the overseas standards such as the United States and Europe are not clear; the experiment of the one to exceed diameters 40 mm or 50 mm was not

carried out in any case.

As the standard of the air-gap, it is required that overflow pipe have enough capacity. However, it is general to assume the size of the overflow pipe to be two size-ups of the diameter of water supply pipe, but clear grounds have not been shown. It is necessary to confirm this validity and the drain capacity of overflow pipe.

To secure the air-gap in water tank with an overflow pipe (hereinafter referred to as water tank), it is necessary to accumulate the basic data for examination the standard of air-gap, such as the maximum drain flow rate and the highest possible water rising level in water tank.

The authors carried out the experiment on FRP water tank with overflow pipe of the inside diameters 50 mm and 100 mm. In this paper, the experiment result on the maximum flow rate, the water level change situation in a water tank, and the method of sizing an overflow pipe are presented.

2. Experiment Overview

2.1. Experiment equipment

The water tank used to the experiment was made of FRP, the size was 1000×1000×2000 mm, and the overflow pipes of diameters 50 mm and 100 mm were installed on each side of the open water tank. The experiment apparatus is shown in Figure 1, and the specification of the experiment materials is shown in Table 1. To make easy for experiment, the ball valves were installed in each overflow pipes, and switching to each pipe in each experiment.

Moreover, the horizontal sectional area of this experiment water tank was assumed to be 1.0 m², because it was estimated that the speed of water level rising from the base level and time until stabilizing the water level were different for a different sectional area, and requested water level rising relation to flow rate and the drain capacity of overflow pipe were not change.

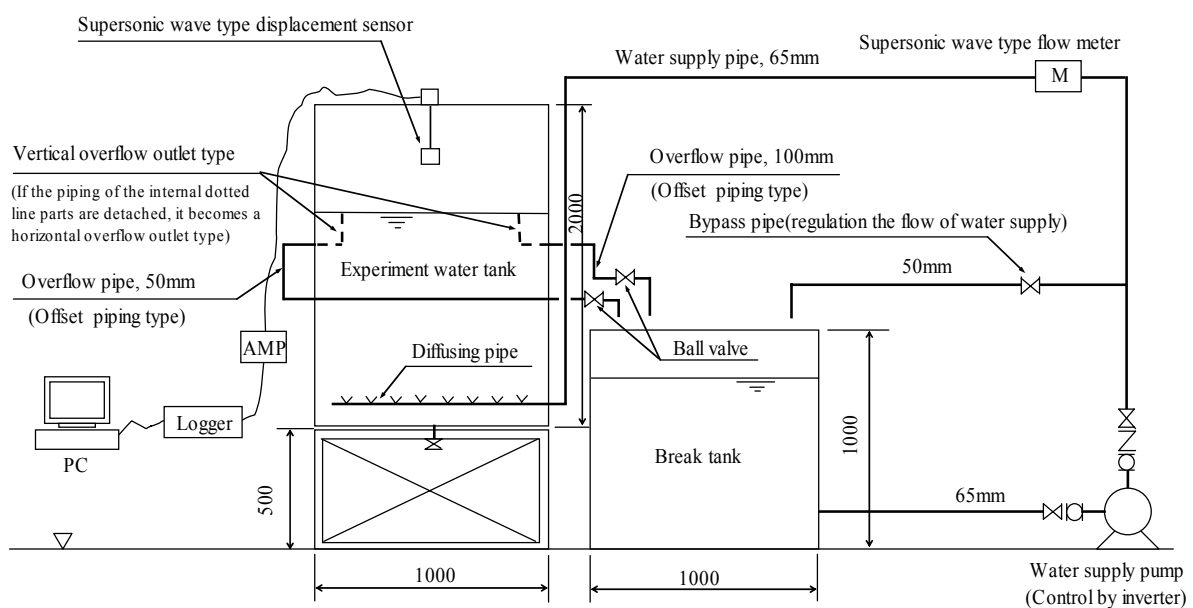

Figure 1 Experiment apparatus

Table 1 Specification of the experiment materials

Item	Specification
Water tank for experiment	Material : made of FRP, single panel type Size:1000×1000×2000 mm
Break tank	Material: made of FRP, single panel type Size:1000×1000×1000 mm
Bell mouth	Material : PVC Pipe diameter : 100 mm, bell mouth part : 145 mm 50 mm, bell mouth part : 75mm
Overflow pipe	Material : VP Diameters:100 mm, 50 mm
Water supply pump	Capacity: 65 A× 500 L / min×10 m×1.5 kW
Inverter	200V, 1.5 kW, 0~50 Hz
Highly accurate supersonic wave type displacement sensor	Time base range:80~300 mm Resolution: 0.1 mm
Data logger	16ch, Sampling interval: 0.1 s
Supersonic wave type flow meter	Application diameter:φ13~φ100 Time base range:-32~0~+32 m/s

It is necessary to keep the stability of the surface of the water to measure the water level change in the water tank when experimenting. Then, the diffusing pipe was installed to connected the water supply pipe (diameter 65 mm) in the tank, the sectional area of the diffusing pipe is 4 times wide of it of the water supply pipe, and the result, the flow velocity in the diffusing pipe has been decreased to about 1/4. In addition, the SUS punching board was installed in the upper layer on the diffusing pipe at the direction of the water flow cross section, and the stabilization of the surface of the water in the tank was achieved. As a result, the water level change in the tank was less than 0.1 mm when water was to be supplying, and the accuracy of the experiment was improved.

2.2. Experiment conditions

Two kinds of outlet types of each overflow pipe (the vertical overflow outlet type and the horizontal overflow outlet type) were set; piping routes was set to each overflow outlet by a straight piping and a offset piping. Table 2 shows the combination and each classification of the overflow outlet type and the piping route of the overflow pipes. Moreover, the piping route and the length on each classification in the vertical overflow outlet type and the horizontal overflow outlet type are shown in Figure 2 and Figure 3. The flow rate was changed to 8 types of overflow pipes shown in Table 2 respectively, the experiment on 112 patterns in total was carried out, and water levels rising in the tank and the maximum drain flow rates of the overflow pipe were confirmed. The flow rates in each experiment pattern are explained in the experiment result.

2.3. Experiment method

Water was supplied from the water supply pump to the experiment water tank, the water level change in the tank was measured by the supersonic wave type displacement sensor, the flow rate and the water level change data were recorded on the personal computer. The water supply flow rate was set according to overflow diameters by 30~780 L/min

(maximum capacity of the water supply pump), and the flow was regulated by installed inverter control of the pump and manual control the ball valves in water supply bypass pipe.

As experiment procedure before experiment of each pattern, first, water is supplied more than overflow respect in the experiment water tank. Then, the water supply was stopped, overflowed afterwards, and the water level that comes to stabilize was recorded as a reference point of the water level in the tank. Naturally, the reference point of the vertical overflow outlet type and the horizontal overflow outlet type is different. Next, to avoid the flow rate change at the time of standing up of the water supply pump and to obtain the steady flow rate water supply, the water level in the tank was adjusted about 10 mm (partially 5 mm) lower than the overflow rim (reference point), then water was to be supplying according to prescribed flow rate, and the water level rising in the tank was recorded.

Table 2 Pattern classification and sign of overflow pipes

Overflow pipe diameter, mm	Vertical overflow outlet type		Horizontal overflow outlet type	
	Piping routes		Piping routes	
	Straight piping type (VS type)	Offset piping type (VO type)	Straight piping type (HS type)	Offset piping type (HO type)
100	V100S	V100O	H100S	H100O
50	V50S	V50O	H50S	H50O

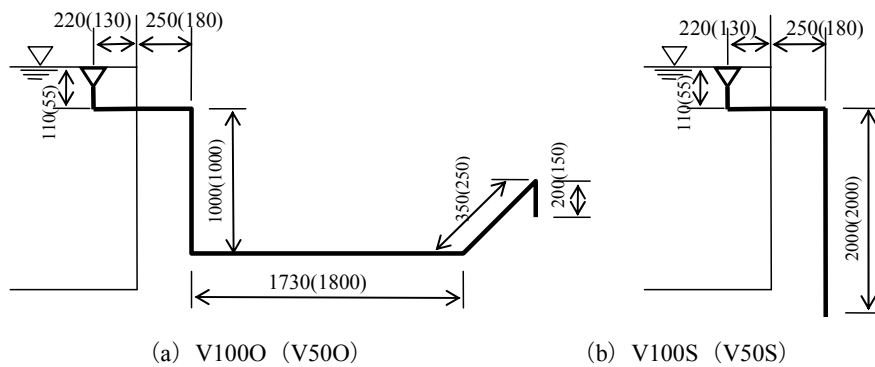

Figure 2 Vertical overflow outlet type

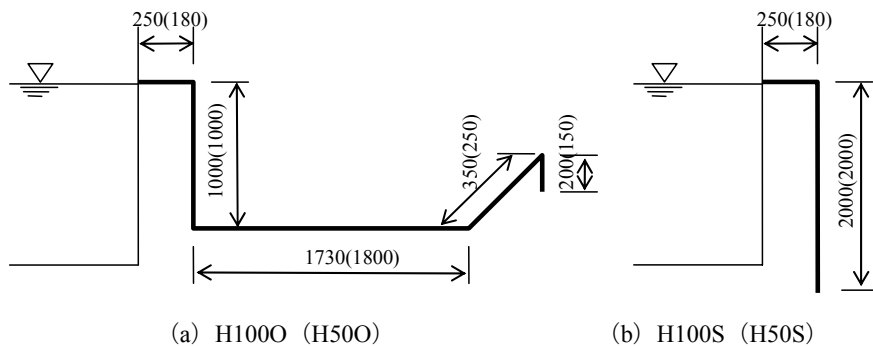

Figure 3 Horizontal overflow outlet type

Note: some both overflow piping lengths of the diameters 100 mm and 50 mm differs in the convenience of the device production as for Figure 2 and Figure 3, and the numerical value in () shows the length of the diameter 50 mm in the figures.

The reference point of the water level in the tank used to calculate the water rising level was made to the bell mouth top side for the vertical overflow outlet type as shown in Figure 4, and made a pipe inside bottom for the horizontal overflow outlet type.

In addition, Water was supplied continuously in the tank within the range of the drain capacity of the overflow pipe, and the case which the water level in the tank almost does not change is called "Water level constancy", in case which the water level rises continuing with the time is called "Rising continuance"

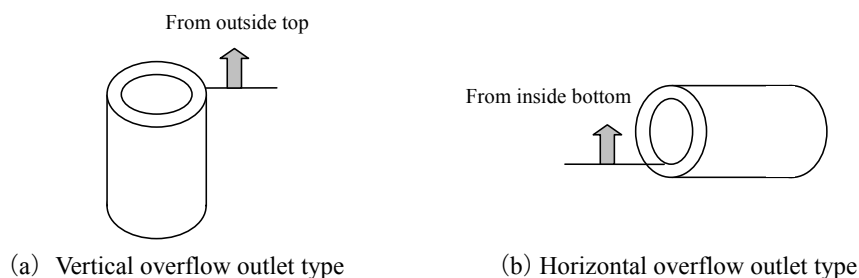

Figure 4 Reference point of water level

3. Experiment result

3.1. Water supply flow rate and water level rising in vertical overflow outlet type

The flow rate was changed to the vertical outlet type overflow pipe, and it was experimented on 28 patterns to the pipes of the diameters 50 mm and 100 mm respectively. As one example, Figure 5 shows the result of the water level rising at V500 (refer to table 2) in case of changing the flow rate from 30 to 180 L/min. When flow rate is 170 L/min or less, the water level in the tank becomes constant after the time passes, the water level in the water tank was raising continuance while flow rate is 180 L/min; it was confirmed that the maximum drain flow rate in V500 is about 170 L/min.

Figure 6 shows the maximum water level rising on the overflow bell mouth top side (water level reference point) in each experiment pattern. The water level rises according to flow rate increase, it doesn't depend on the piping route of the overflow pipe, and al-

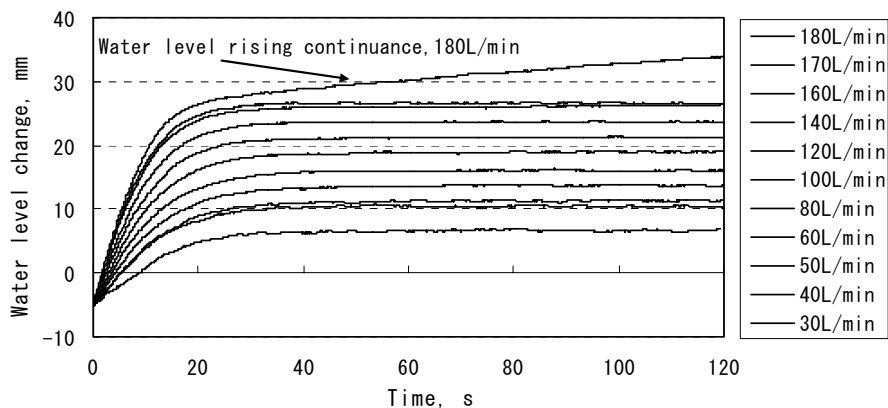

Figure 5 Flow rate and water level change in V500

most the same water rising level for the same flow rate and the same size of overflow pipe. The water rising level of the diameter 50 mm is higher than it of the 100 mm for the same flow rate.

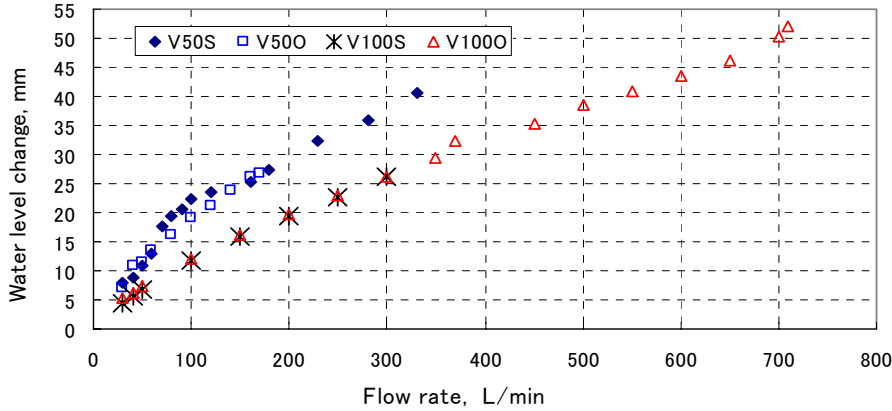

Figure 6 Water rising level and flow rate in vertical overflow outlet type

3.2. Water supply flow rate and water level rising in horizontal outlet type

The flow rate was changed to the horizontal outlet type overflow pipe, and it was experimented on 56 patterns in total of 30 and 26 respective to the pipes of diameters 50 and 100mm. As one example, Figure 7 shows the result of the water rising level at H500 in case of changing the flow rate from 30 to 200 L/min. When flow rate is 190 L/min or less, the water level in the tank becomes constant after the time passes, the water level in the water tank was raising continuance while flow rate is 200 L/min; it was confirmed that the maximum drain flow rate in H500 is about 190 L/min.

Figure 8 shows the maximum water level rising at the bottom side on the overflow pipe inside (water level reference point) in each experiment pattern. The water level rises according to a flow rate increase in H1000 and H100S, it doesn't depend on the piping route of the overflow pipe, and almost the same water level rising for the same flow rate and same size of overflow pipe. For H500 and H50S, though the siphonage is repeatedly generated in H50S, and the water level doesn't rise to a flow rate increase. Even if the same size of overflow pipe, the water level rising in a straight piping type is higher than the offset piping type as a whole.

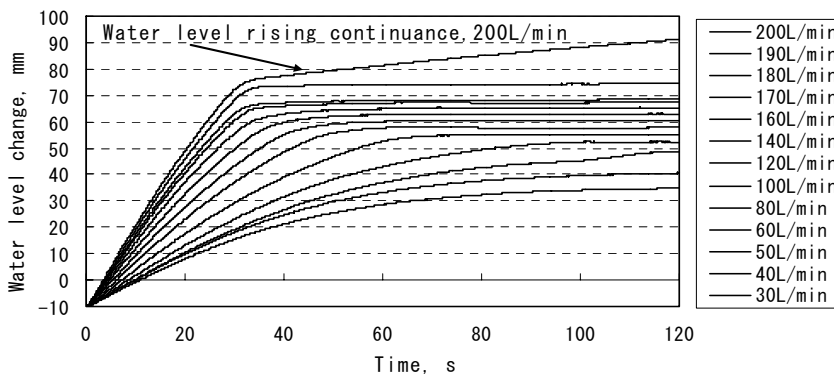

Figure 7 Flow rate and water level change in H500

Figure 9 shows the water level change when siphonage was generated at water supply flow rate 100 L/min in H50S. The siphonage occurs repeatedly after becoming the maximum water rise in the tank; the range of the water level change is almost the same when siphonage is generated in each time, and the water level rising before the first siphonage is generated is the maximum.

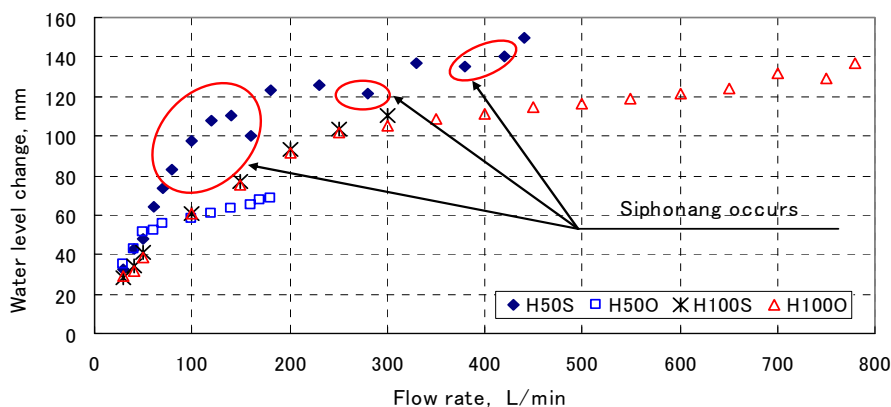

Figure 8 Flow rate and water rising level in horizontal overflow outlet type

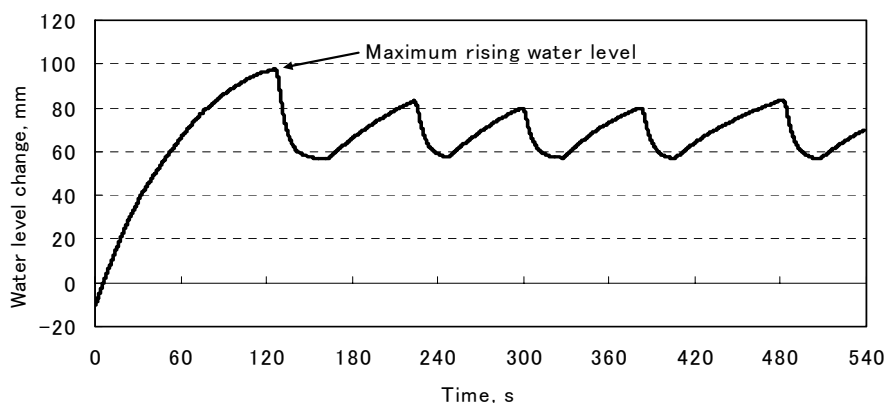

Figure 9 Water level change when siphonage is generated (H50S, 100 L/min)

3.3. The maximum flow rate of overflow pipes

Table 3 shows the maximum drain flow rate of the overflow pipes of diameters 50mm and 100mm. The maximum flow rate in horizontal outlet type is more than the Vertical outlet type in the diameter 50 mm, and even if the same overflow outlet type, the straight piping type is about twice as large as the offset piping type. In the diameter 100mm, only V100O was able to be confirmed to the maximum drain flow rate by restricted experimental conditions.

Table 3 Maximum drain flow rates

Overflow pipe diameter, mm	Maximum drain flow rate, L/min			
	V50S	V50O	H50S	H50O
50	360	170	440	190
100	V100S	V100O	H100S	H100O
	—	710	—	—

4. Discussion about water level rising

4.1. Vertical overflow outlet type

The water level rising in the water tank as h , and overflow diameter as d , a multivariate multiple regression analysis was performed about the ($h/d \leq 1.0$) experiment data that the siphonage was not generated. It doesn't depend on diameter in the same outlet type and the same piping route of overflow pipe, and it is possible to express by one regression formula in the condition of $h \leq d$.

Equation (1) was obtained for the VS type (Vertical outlet Straight piping type), and equation (2) was obtained for the VO type (Vertical outlet Offset piping type) in the condition of $h/d \leq 1.0$. The multiple correlation coefficients are 0.994 and 0.999 respectively, which shows the both correlations are high.

$$h=9.870 \frac{Q^{0.731}}{d^{0.700}} \dots\dots\dots (1)$$

$$h=8.104 \frac{Q^{0.715}}{d^{0.627}} \dots\dots\dots (2)$$

where, h = water rising level in water tank, mm
 Q =overflow flow rate, L/min
 d =internal diameter of overflow pipe, mm

The water rising level as which the straight piping and the offset piping type are almost the same in case of the same flow rate and same diameter, moreover, the actual overflow piping route is general a straight piping, therefore, equation (1) of the straight piping type is used to examine sizing method of the vertical outlet type overflow pipe.

4.2. Horizontal overflow outlet piping type

In the experiment of vertical overflow outlet type, it was possible to express by one regression formula in the condition of water rising level $h \leq d$ if the same piping route, but in horizontal overflow outlet type, as water rising level situation in $h \leq d$ (the siphonage was not generated) and the water level uptrend of $h > d$ (the siphonage might be generated in H50S) is different, a multivariate multiple regression analysis was performed for the experiment data separately in case of $h \leq d$ and $h > d$.

Each empirical formula in $h \leq d$ and $h > d$ of the HS type (Horizontal outlet Straight piping type) is expressed as (3) and (4). The multiple correlation coefficients are 0.999 and 0.953 respectively.

$$h=11.518 \frac{Q^{0.626}}{d^{0.265}} \quad (h/d \leq 1.0) \dots\dots\dots (3)$$

$$h=48.991 \frac{Q^{0.352}}{d^{0.260}} \quad (h/d > 1.0) \dots\dots\dots (4)$$

Each empirical formula in $h \leq d$ and $h > d$ of the HO type (Horizontal outlet Offset piping type) is shown in formula (5) and (6). Either of the multiple correlation coefficient is 0.999.

$$h=16.541 \frac{Q^{0.618}}{d^{0.341}} \quad (h/d \leq 1.0) \dots\dots\dots (5)$$

$$h=3.292 \frac{Q^{0.234}}{d^{0.462}} \quad (h/d>1.0) \dots\dots\dots (6)$$

As well as the Vertical outlet piping type, the actual overflow piping route is general a straight piping, so, it is thought that formula (3) and formula (4) for straight piping type only has to use when empirical formula to be used.

Moreover, because the water rising level from the state ($h>d$) that the overflow pipe goes under water as shown in Figure 8 is more gradual than the case of state $h \leq d$, to make the calculation concise, formula (3) is the safety side is used to examine sizing method of the horizontal outlet type overflow pipe.

5. Examination of sizing method for overflow pipe

5.1. Water supply flow velocity (flow rate)

Overflow outlet might be submerged by the water which supplies the flow velocity (flow rate). Under the condition, it is assumed that the time is required to drain it until becoming a reference point of water level from rising water level in the tank by shape and a plane area of the water tank, when sudden stop of the water supply. There is a possibility that a back-siphonage is generated at once in this time though it is not easy to think.

As the standard of the air-gap, it is required overflow pipe having enough capacity; it is general to assume the size of the overflow pipe to be two size-ups of the size of water supply pipe. So far the flow velocity of water supply is calculated at flow velocity 2 m/s. When water flowing to the tank as continuously as the water supply pipe, the corrosion measures etc. for pipes are considered, and 1.0 to 1.2 m/s of flow velocity is preferable, according to circumstances, the water supply flow velocity can be selected even 2.0 m/s.

5.2. Sizing method for overflow pipe

As a method of sizing overflow pipe, two methods in the following are proposed. Method A: So as not to exceed allowance rising point, then the size is decided; method B: the size of overflow pipe is made to 2 size-ups of the water supply pipe, and the water supply flow velocity to the tank is limited. Where, the height on the permissible rising point is set as well as air-gap standard value. In method A, after the water supply flow velocity to the water tank is decided, and then water supply flow rate Q and water rising level h are known, the size of the overflow pipe can be calculated by using formula (1) or formula (3). In method B, water rising level h and the overflow pipe size d are known, the water supply flow rate can be calculated by using formula (1) or formula (3), and then the water supply flow velocity can be decided.

The relation between the water supply flow velocity (flow rate) and water level rising and diameter in vertical outlet type overflow piping are shown in Table 4, and the case of horizontal outlet type is shown in Table 5. Though the water supply flow velocity and the size of overflow pipe are not shown in the table, these can be calculated by using formula (1) or (3).

When Table 4 was compared with Table 5, in the same water supply flow rate, the water rising level of the vertical outlet type in the tank is lower than that of the horizontal overflow outlet type. Therefore, the vertical overflow outlet type is preferable designing

Table4 Size of overflow pipe and water level rising in vertical outlet type

Water supply Pipe Diameter, D, mm	Velocity of water supply, V, m/s				Overflow Pipe Diameter, d, mm	Velocity of water supply, V, m/s			
	1	1.2	1.5	2		1	1.2	1.5	2
	Flow Rate of water supply*, Q, L/min					Water level rising in water supply flow rate shows left, h, mm			
					Vertical overflow outlet type, $h=9.870Q^{0.731}/d^{0.700}$				
20	17	20	25	32	32	6.9	7.8	9.2	11.0
					40	5.9	6.7	7.8	9.4
					50	5.1	5.7	6.7	8.0
25	28	35	42	65	40	8.5	10.0	11.5	15.8
					50	7.3	8.6	9.8	13.5
					65	6.1	7.1	8.2	11.2
32	50	62	75	100	50	11.1	13.0	15.0	18.5
					65	9.3	10.9	12.5	15.4
					80	8.0	9.4	10.8	13.3
40	70	87	105	145	65	11.9	13.9	16.0	20.2
					80	10.3	12.0	13.8	17.5
					100	8.8	10.3	11.8	14.9
50	120	150	180	250	80	15.2	17.9	20.5	26.0
					100	13.0	15.3	17.5	22.2
					125	11.1	13.1	15.0	19.0
65	200	250	300	400	100	18.9	22.2	25.4	31.4
					125	16.2	19.0	21.7	26.8
					150	14.2	16.7	19.1	23.6
80	280	350	405	570	125	20.7	24.3	27.1	34.8
					150	18.2	21.4	23.8	30.6
					175	16.3	19.2	21.4	27.5
100	500	600	730	1000	150	27.8	31.8	36.7	46.1
					175	25.0	28.5	32.9	41.4
					200	22.7	26.0	30.0	37.7

Table 5 Size of overflow pipe and water level rising in horizontal outlet type

Water supply Pipe Diameter, D, mm	Velocity of water supply, V, m/s				Overflow Pipe Diameter, d, mm	Velocity of water supply, V, m/s			
	1	1.2	1.5	2		1	1.2	1.5	2
	Flow Rate of water supply*, Q, L/min					Water level rising in water supply flow rate shows left, h, mm			
					Horizontal overflow outlet type, $h=11.518Q^{0.626}/d^{0.265}$				
20	17	20	25	32	32	27.0	29.9	34.4	40.1
					40	25.5	28.2	32.4	37.8
					50	24.0	26.6	30.5	35.6
25	28	35	42	65	40	34.8	40.0	44.8	58.9
					50	32.8	37.7	42.2	55.5
					65	30.6	35.2	39.4	51.8
32	50	62	75	100	50	47.1	53.9	60.7	72.6
					65	43.9	50.3	56.6	67.8
					80	41.6	47.6	53.6	64.1
40	70	87	105	145	65	54.2	62.1	69.9	85.5
					80	51.3	58.8	66.1	80.9
					100	48.4	55.4	62.3	76.3
50	120	150	180	250	80	71.9	82.6	92.6	113.7
					100	67.8	77.9	87.3	107.2
					125	63.9	73.4	82.3	101.0
65	200	250	300	400	100	93.2	107.2	120.1	143.8
					125	87.9	101.0	113.2	135.5
					150	83.7	96.3	107.9	129.1
80	280	350	405	570	125	108.5	124.7	136.6	169.1
					150	103.3	118.8	130.2	161.1
					175	99.2	114.0	124.9	154.7
100	500	600	730	1000	150	148.5	166.4	188.1	229.0
					175	142.5	159.7	180.6	219.8
					200	137.6	154.2	174.3	212.2

* : Flow rates are calculated by Hazen-Williams Equation (SHASE-S206-2000, p208)

on engineering design.

6. Conclusion

The experimental investigations of FRP water tank with the overflow pipes of inside diameters 50 mm and 100 mm were presented. The following conclusions were obtained:

- (1) When the siphonage is not generated in both vertical overflow outlet type and the horizontal overflow outlet type, the water rising level in the tank is almost equal without depending on the piping route in case of the same overflow outlet type.
- (2) In the case of the same overflow outlet type of the overflow piping, the influence that the piping route gives the capacity of overflow pipe is great. The overflow capacity of the straight piping type is about twice as large as the offset piping type.
- (3) Water rising level in the vertical outlet type of the overflow piping is lower than horizontal overflow outlet type; it is thought that the straight piping route of the vertical overflow outlet type is preferable.
- (4) Empirical formula where water rising level in the water tank to be presented by flow rate and size of overflow pipe was shown.
- (5) The sizing method of the overflow pipe by presented empirical formula was proposed.

Acknowledgments

This project is performed as the activity of "Water supply and drainage sanitary equipment committee, air-gap review subcommittee", of the Society of Heating, Air-conditioning and Sanitary Engineers of Japan. The authors thank Tomoo Inada and Hideharu Doi in Suga Co., Ltd.; Ryuma Ouchi and Yuta Yamafuji in Kanakaga University (at that time), they have cooperated in experiment, and authors wish to thank all the committee members.

References

- 1) Takamasa Shinohara et al. The air-gap of large diameter in the water supply system, SHASE Vol.47, no.6, 1973.12, pp.29–44
- 2) Takamasa Shinohara et al. The air-gap of large diameter in the water supply system, SHASE Symposium, 1997.10, pp.185–188
- 3) Ken Majima, et al. Water Rise in Water Tanks with Overflow Pipes (Part 1) Preliminary Experiment on Water Closet Flush Tanks and Small Tanks, SHASE Symposium, 2005.8, pp.26~29
- 4) Xinagwu Wang, et al. Water Rise in Water Tanks with Overflow Pipes (Part 2) Experimental Study on Water Level Change and Flow Rate of Overflow Pipes, SHASE Symposium, 2005.8, pp.29~32
- 5) Fumitoshi Kiya, et al. Experimental study on the air-gap, SHASE Vol.78, no.6, 2004.6, pp.19-27

- 6) Plumbing Code, SHASE—S206—2000, the Society of Heating, Air-conditioning and Sanitary Engineers of Japan, 2000,3, pp.58,59
- 7) Roy B.Hunter, Gene E.Golden, and Herbert N.Eaton. Cross connection in Plumbing System, April 1938, Research Paper RP1089 Part of Journal of Research of the National Bureau of Standards, Volume 20.
- 8) F.M.Dawson, A.A.Kalinske. Report on Plumbing Cross Connections and Back Siphonage Research. 1938, Technical Bulletin Number 1, National Association of Master Plumbers of the United States, Incorporated.

Presentation of Author

Xiang-Wu Wang, Ph.D., is the Researcher at SUGA Co., Ltd., Research & Development Center. His Specialized field is architectural environmental engineering; he also acts as referee of overseas paper edit committee of the Society of Heating, Air-Conditioning and Sanitary Engineers of Japan, and committee of water environmental committee of Architectural Institute of Japan.

