

Testing Whether Two Chaotic One Dimensional Processes Are Dynamically Identical

Guo-Cheng Yuan,¹ James A. Yorke,² Thomas L. Carroll,³ Edward Ott,² and Louis M. Pecora³

¹*Division of Applied Mathematics, Brown University, Providence, Rhode Island 02912*

²*University of Maryland, College Park, Maryland 20742*

³*Naval Research Laboratory, Washington, D.C. 20375-5000*

(Received 30 March 2000)

Consider the situation where two individuals observe the same chaotic physical process but through time series of different measured variables (e.g., one individual measures a temperature and the other measures a voltage). If the two individuals now use their data to reconstruct (e.g., via delay coordinates) a map, the maps they obtain may appear quite different. In the case where the resulting maps appear one dimensional, we introduce a method to test consistency with the hypothesis that they represent the same physical process. We illustrate this method using experimental data from an electric circuit.

PACS numbers: 05.45.Tp, 07.50.Ek

In the case of chaotic physical processes, in many situations it has proven possible, via examination of output data only, to obtain a reconstruction of a dynamics corresponding to the observed system [1]. The selection of outputs, of course, is quite arbitrary. A natural question that arises is how two observers, who use their own choices of outputs, are able to tell whether they are studying the same dynamical process.

In this paper we present a method that can be used to test consistency with the hypothesis that two one dimensional maps originate from the same physical process. We imagine that these maps are obtained by, for example, using time-delay embedding [1] or by recording consecutive points at which a phase space trajectory intersects with a surface of section, i.e., a Poincaré return map.

Figure 1 shows a measured trajectory observed in an experiment conducted on an electrical circuit [2]. (See Fig. 2 and its caption.) We denote this trajectory by $\mathbf{X}(t)$, where $\mathbf{X} = (x, y, z)$. It appears that this trajectory asymptotes to a two dimensional chaotic attractor. Using $x = 0$ as a surface of section, we record the y coordinate every time \mathbf{X} intersects $x = 0$ with $dx/dt > 0$. Thus we obtain a sequence $\{y_n\}$. We plot y_{n+1} versus y_n in Fig. 3(a). This appears to result in a one dimensional map, which we denote f_y . There is noticeable scatter of the data about the apparent f_y curve. Part of this scatter is caused by the finite bandwidth in the electronics used to trigger the digitizer to sample the y signal. The finite bandwidth causes a slight delay between the time \mathbf{X} intersects $x = 0$ and the actual time at which y is sampled. The noise may also be partly dynamical (due to the fact that the attractor dimension is slightly greater than 2). For convenience, we refer to this total scatter as noise. Another way to obtain a reconstruction of the dynamics from the data is by recording consecutive maxima in the x coordinate, denoted by $\{x_n\}$. In Fig. 3(b) we plot the map defined by $f_x: x_n \mapsto x_{n+1}$. This map looks quite different from the map in Fig. 3(a). We address the following question: If one is presented with the plots in Figs. 3(a) and 3(b), can one test to determine consistency with the hypothesis that the two represent

different reconstructions obtained from the same chaotic process?

Let $A = [c, d]$ be a chaotic one dimensional attractor on which the dynamics is given by a continuous map $x_{n+1} = f(x_n)$ for x_n in A with the following properties: (i) f admits a natural measure μ (i.e., the measure of an open interval B is the fraction of iterates that a typical trajectory spends in B); (ii) any subinterval of $[c, d]$ has positive natural measure [3]. Using the natural measure μ , we define a change of coordinate $h: [c, d] \rightarrow [0, 1]$ by letting $w_n := h(x_n) := \mu([c, x_n])$, i.e., w_n is equal to the natural measure to the left of x_n . In terms of w_n , the map f is transformed to a new map $g: [0, 1] \rightarrow [0, 1]$ given by $g(w_n) := h \circ f \circ h^{-1}(w_n)$. [A similar construction is via the change of variable $\bar{h}(x_n) := \mu([x_n, d])$. This will result in a map which is the same as g except for flipping over each axis once. We do not distinguish between the two.] We call g the *canonical conjugate* of f . That two one dimensional maps have identical canonical conjugates would suggest that they originate from the same physical process [4].

Notice that, by construction, the map $g(w_n)$ generates chaotic trajectories whose natural measure corresponds to a uniform density for w_n in $[0, 1]$. Since f and g differ

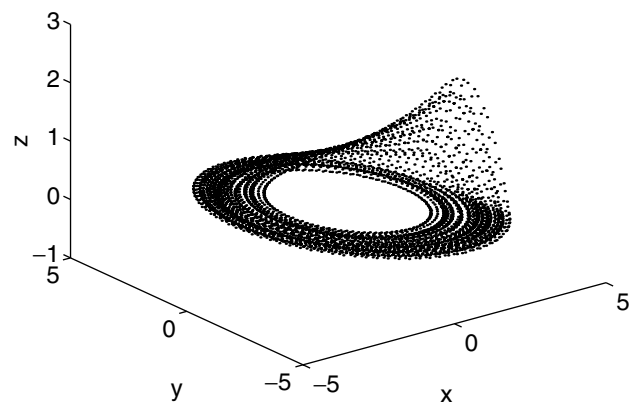

FIG. 1. The attractor observed in our experiment.

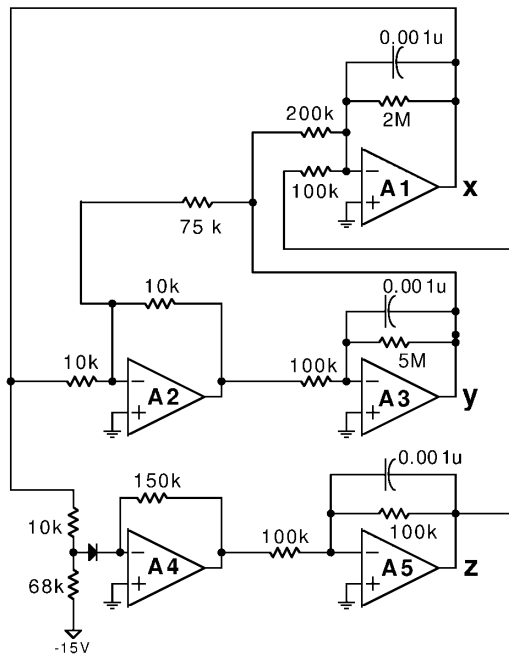

FIG. 2. The electric circuit used to generate the data for this paper. The x , y , and z signals are measured at the points labeled x , y , and z . The only nonlinear element in the circuit is the diode at the input to output amplifier A4.

only by a change of coordinate, the topological dynamics of f and g are the same. In particular, for every periodic orbit of f there is a corresponding periodic point of g with the same period. Most importantly, f and g have the same Lyapunov exponent (with respect to their natural measure); this is easy to see if h is piecewise smooth, but it is also suggested in greater generality by Pesin's formula [5], which asserts that (under some technical conditions) the Lyapunov exponent is equal to the metric entropy. Therefore, if two one dimensional maps f_1 and f_2 with canonical conjugates g_1 and g_2 are dynamically different, their difference can be evaluated by comparing g_1 with g_2 . This will be discussed later in more detail [see Eq. (1)].

In physical experiments noise and measurement errors are unavoidable; thus two maps that are close together cannot be distinguished by our method. A more serious challenge is due to the fact that trajectories that appear to be chaotic may eventually settle on a periodic attractor, as is the case for the logistic maps at certain parameter values. As a result, one cannot rigorously check whether a canonical conjugate is meaningful. Nonetheless, in many situations, experimental data are highly consistent with the assumption of the existence of a chaotic one dimensional attractor that satisfies our two conditions; therefore we expect that our method can be applied to a wide class of experiments. To demonstrate how this is possible, in the following we present results of applying the canonical conjugate method to a simple experiment, where both noise and measurement errors are present.

As an example, we compare the canonical conjugates of f_y and f_x of Figs. 3(a) and 3(b). We first calculate

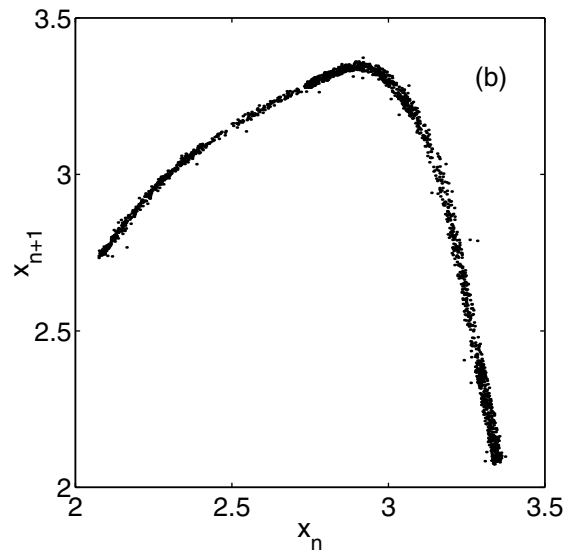
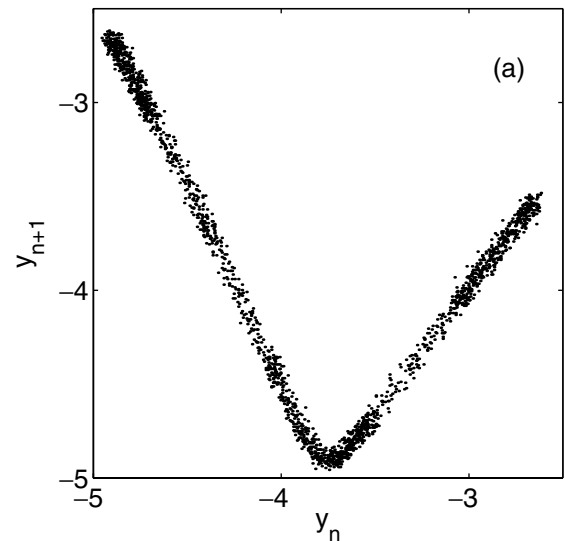

FIG. 3. Chaotic maps obtained by experimental data. (a) f_y : the Poincaré return map at $x = 0$; (b) f_x : the return map obtained by recording consecutive maxima of x .

the canonical conjugate of f_y , denoted by g_y . This can be obtained by the following steps. First, rescale the data with respect to the natural measure. That is, associate to y a new coordinate value w , $w := h_y(y)$, where w represents the natural measure (fraction of data points) to the left of y . Next, replot the map in terms of the new variable w (not shown). Finally, fit the plot with a piecewise linear map. The curve in Fig. 4 shows g_y obtained by piecewise linear fitting, for which we have applied the constraint $1/|g'_y(w_1)| + 1/|g'_y(w_2)| = 1$ for all w_1 and w_2 for which $g_y(w_1) = g_y(w_2)$. This constraint is known as the Perron-Frobenius equality, which is the necessary and sufficient condition for the density generated by $g_y(w)$ to be constant. The Lyapunov exponent of g_y is simply $\lambda_y = \int_0^1 \log|g'_y(w)| dw$. Using this, we get $\lambda_y \approx 0.42$.

Although there is no simple formula that associates the sequence $\{y_n\}$ (obtained from the $x = 0$ surface of section)

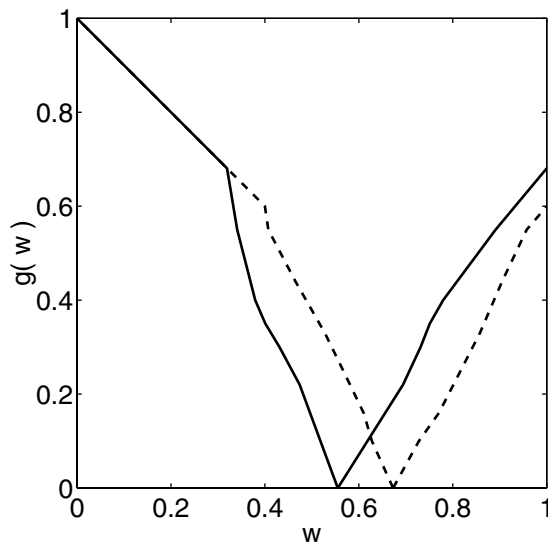

FIG. 4. The solid curve displays g_y (g_x and g_θ fall within the thickness of this curve). The dashed curve displays g_p .

with $\{x_n\}$ [the successive maxima of $x(t)$], either map can be obtained from the other by a coordinate change. We compute the canonical conjugate of f_x , denoted by g_x , using the same algorithm. It agrees so well with g_y that each curve falls into the thickness of the other; therefore, we do not show g_x separately. This apparent similarity between g_x and g_y suggests that f_y and f_x correspond to the same dynamical process.

In general, a different surface of section will lead to a different Poincaré return map. We have arbitrarily chosen several different surfaces and find good agreement between their associated canonical conjugates.

As another example, Fig. 5 shows the cross section of the attractor in the x - z plane at $y = 1$. In this case, our procedure to evaluate the return map needs to be modified. In particular, we first perform a change of coordinates to unfold the attractor; the specific choice of this change of coordinate is somewhat arbitrary. As an example of one such unfolding, we choose the polar coordinate (r, θ) with the origin at the point $(x_0, z_0) = (2.5, 0.6)$. In terms of θ the return map is well defined (i.e., considering the cross section of the attractor shown in Fig. 5(a) is one dimensional, there is a one-to-one relationship between points in the cross section and values of θ) and is shown in Fig. 5(b). Comparing Fig. 5(b) with Fig. 3(a), we find no noticeable similarities. However, the canonical conjugate g_θ agrees well with g_y . In fact, our plot of g_θ also falls into the thickness of the line plotting g_y in Fig. 4.

Finally, we investigate a situation where the return map is one dimensional but discontinuous. Similarly to Fig. 3(b), we generate a sequence $\{z_n\}$ by recording consecutive peaks in the z coordinate. We then define a map $f_z: z_n \mapsto z_{n+1}$. Figure 6(a) shows that f_z is discontinuous. The reason is that in our experiment certain maxima are missed when the signals are below a detectable threshold. To understand what is happening

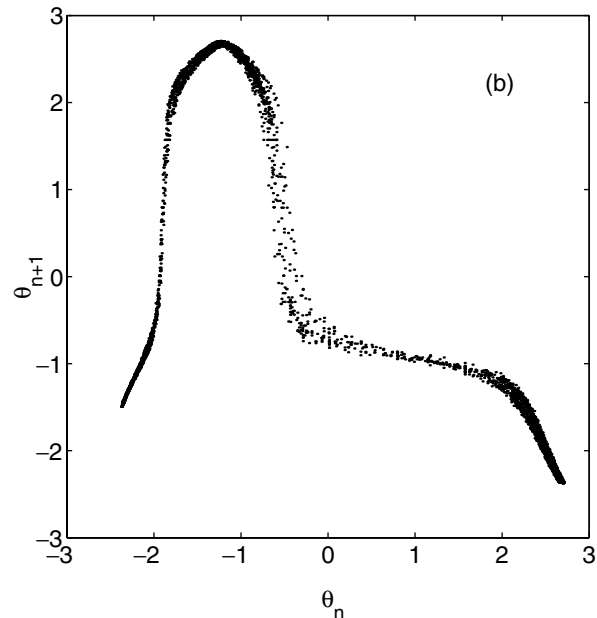
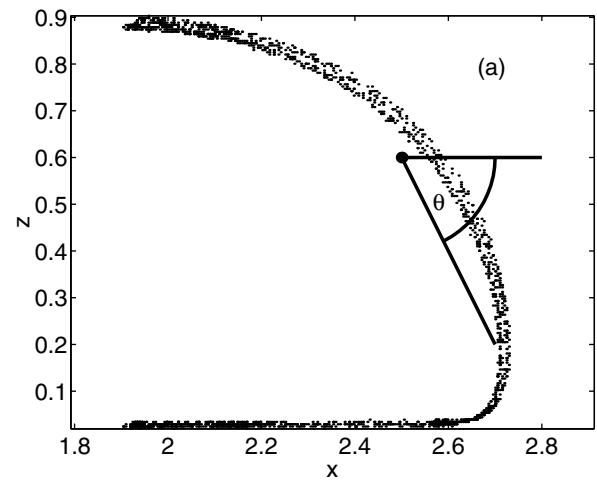

FIG. 5. (a) The cross section of the attractor at $y = 1$; (b) f_θ : the unfolded return map at $y = 1$.

refer to Fig. 1. The geometry of the chaotic attractor is roughly like an annulus, and the orbit on the attractor circles around the inner hole. Successive values of y_n and x_n correspond to successive circuits around the attractor. When one (two) maximum (maxima) of z is missed between z_n and z_{n+1} , two (three) circuits are taken between z_n and z_{n+1} . In Fig. 6(a) we observe that $1.1 > z_n > 0.2$ corresponds to one circuit, $1.8 > z_n > 1.1$ corresponds to two circuits, and $z_n > 1.8$ corresponds to three circuits. To compare f_z with the other maps we discussed before, for example, f_y , we generate a new canonical conjugate \tilde{g}_y as follows. We regard the region $w > w_*$ for $g_y(w)$ as “below the detectable threshold” (i.e., the z coordinate is small). When $w_n > w_*$, we iterate again until $w < w_*$, and we regard this as the new w_n . In this way we obtain a map $\tilde{g}_y(w)$. Figure 6(b) compares g_z with \tilde{g}_y when the threshold is $w_* = 0.54$, which is chosen to give the best match.

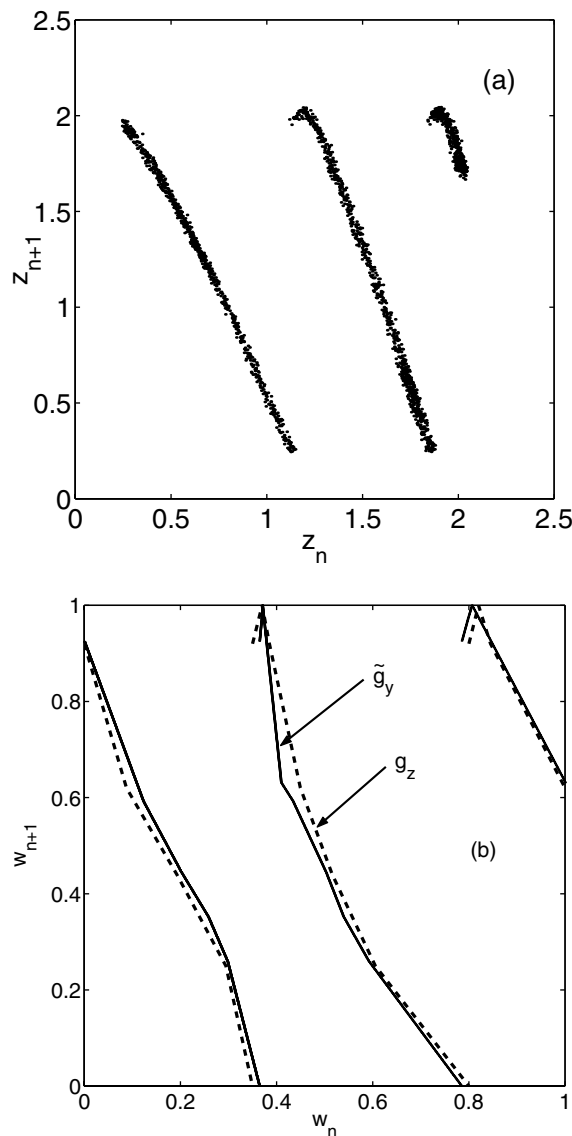

FIG. 6. The returned map f_z , obtained by recording consecutive local maxima of z , is shown in (a), and its canonical conjugate g_z is shown as the dashed curve in (b). The latter is compared with \tilde{g}_y [the solid curve in (b)], which corresponds to g_y with the threshold at $w_* = 0.54$.

We also test our method for a one dimensional map f_p which is obtained from a similar circuit but with a slightly different parameter [6]. Its canonical conjugate g_p is shown in Fig. 4 as the dashed curve. The difference is significant. A way of quantifying this difference is discussed below.

We can define a coordinate independent difference between two chaotic one dimensional maps f_1 and f_2 by using canonical conjugates. Let $g_1(w)$ and $g_2(w)$ be the canonical conjugates of f_1 and f_2 , respectively. Their difference can be quantified by the following metric:

$$d(f_1, f_2) := d(g_1, g_2) := \int_0^1 [\log|g'_1(w)| - \log|g'_2(w)|] dw. \quad (1)$$

It follows immediately that $d(g_1, g_2) \geq |\lambda(g_1) - \lambda(g_2)|$, where $\lambda(g_i)$, $i = 1, 2$, is the Lyapunov exponent of g_i . On the other hand, two maps that have the same Lyapunov exponent may not be dynamically similar and the distance between them may not be small. For the examples discussed in this paper, we find g_y , g_x , and g_θ , which are derived from the same circuit, are within 0.07 of each other with respect to this metric, whereas $d(g_p, g_y)$ is approximately equal to 0.28, which is considerably larger even though their Lyapunov exponents are almost equal [$\lambda(g_p) = 0.41 \pm 0.02$, $\lambda(g_y) = 0.43 \pm 0.02$].

In conclusion, we have introduced a method whereby, given two one dimensional chaotic maps, we can compute and compare their canonical conjugates to check if they might represent the same physical process, i.e., if they have the same dynamical properties. We have demonstrated that this method is robust in that it can be implemented in a laboratory experiment in which noise is present.

This research was supported by NSF and ONR (physics) grants to University of Maryland. G. Y. was also supported by an ONR grant to Brown University.

[1] E. Ott, T. Sauer, and J. A. Yorke, *Coping with Chaos* (John Wiley & Sons, New York, 1994), pp. 41–62; H. D. I. Abarbanel, *Analysis of Observed Chaotic Data* (Springer, New York, 1996), pp. 13–23; H. Kantz and T. Schreiber, *Non-linear Time Series Analysis* (Cambridge University Press, Cambridge, England, 1997).

[2] T. L. Carroll, *Am. J. Phys.* **63**, 377 (1995).

[3] If the attractor cycles through m component intervals disconnected from each other, then we can apply our construction by considering the action of f^m on one of the component intervals. Although not mathematically proven, it is commonly anticipated that chaotic attractors in one dimensional maps typically consist of a finite number (often one) of component intervals.

[4] One can also test whether two one dimensional maps $x_{n+1} = f_1(x_n)$, $y_{n+1} = f_2(y_n)$ originate from the same physical process without using the canonical conjugates. In particular, we consider the following coordinate change $y := h_2^{-1} \circ h_1(x)$, where $h_1(x)$ [respectively, $h_2(y)$] represents for $f_1(x)$ [respectively, $f_2(y)$] the natural measure to the left of the point x (respectively, y). Thus the map $f_1(x)$ is transformed to a new map $f_*(y)$. That f_* and f_2 are identical suggests that f_1 and f_2 represent the same physical process.

[5] Ya B. Pesin, *Russ. Math. Survey* **32**, No. 4, 55 (1977).

[6] The dynamics of the circuit can be approximately described by a set of three ordinary differential equations. The third equation is $dz/dt = f(x) - z$, where $f(x) = 0$ for $x < 3$ and $f(x) = k(x - 3)$ for $x \geq 3$ [2]. For the circuit that produced g_y , g_x , and g_θ , k was chosen as $k = 15$. For the circuit that produced g_p , k was changed to $k = 10$.