

## DYNAMIC LOADING OF INTERNAL LINKAGES OF THE VVER 1000 TYPE REACTOR EXCITED BY PRESSURE PULSATION

Vladimír Zeman, Zdeněk Hlaváč\*

*The paper deals with the mathematical modelling and the computer simulation of forced vibrations of the reactor core barrel excited by pressure pulsations generated by main circulation pumps. The modelling is focused on a possible core barrel flange slip along a pressure vessel flange. The slip in this internal reactor linkage is analysed providing the solid friction and the backlash between slip tongues of the pressure vessel flange and grooves in the core barrel flange. The impact motion can produce an excessive abrasive wear of the tongues and grooves. A guarantee of the fail-safe operation is achieved by calculated pre-stressing of toroidal tubes inserted between the upper flange of the core barrel and the pressure vessel cover.*

Keywords: reactor vibration, pressure pulsations, internal linkages, solid friction, dynamic loading

### 1. Introduction

Many diagnostic measurements of reactor vibrations showed an existence of discrete set of frequencies corresponding to revolutions of main circulation pumps (MCP's) and their integral multiple [1]. The rotor revolutions of individual MCP's in particular pipe loops are slightly different. Consequently, the pressure pulsations in the section of pump cooling medium outlet till the reactor pressure vessel inlet generate the polyharmonic hydrodynamic forces [2] in the space between the pressure vessel (PV) and the core barrel (CB) walls (Fig. 1) having slightly different frequencies. As a result, the reactor vibrations have a beat character and the contact loss in the core barrel suspension at the pressure vessel flange can occur [3]. The new phenomenon, characterized by excessive abrasive wear of the tongues of pressure vessel flange and grooves in the core barrel flange, was caused after demounting this internal linkage.

The goal of the paper is to use the discrete mathematical model of the VVER 1000 reactor derived in [3] under the condition of the elimination of core barrel flange slip along a pressure vessel flange, for study of nonlinear phenomenon called by slipping.

### 2. Mathematical model of reactor and condition for slip elimination

Mathematical model of the VVER 1000/320 type reactor excited by pressure pulsations was derived in [3] by the decomposition method presented in [4]. Under the conditions of

---

\* prof. Ing V. Zeman, DrSc., doc. RNDr. Zdeněk Hlaváč, CSc., University of West Bohemia, Faculty of Applied Sciences, Univerzitní 22, 306 14 Plzeň

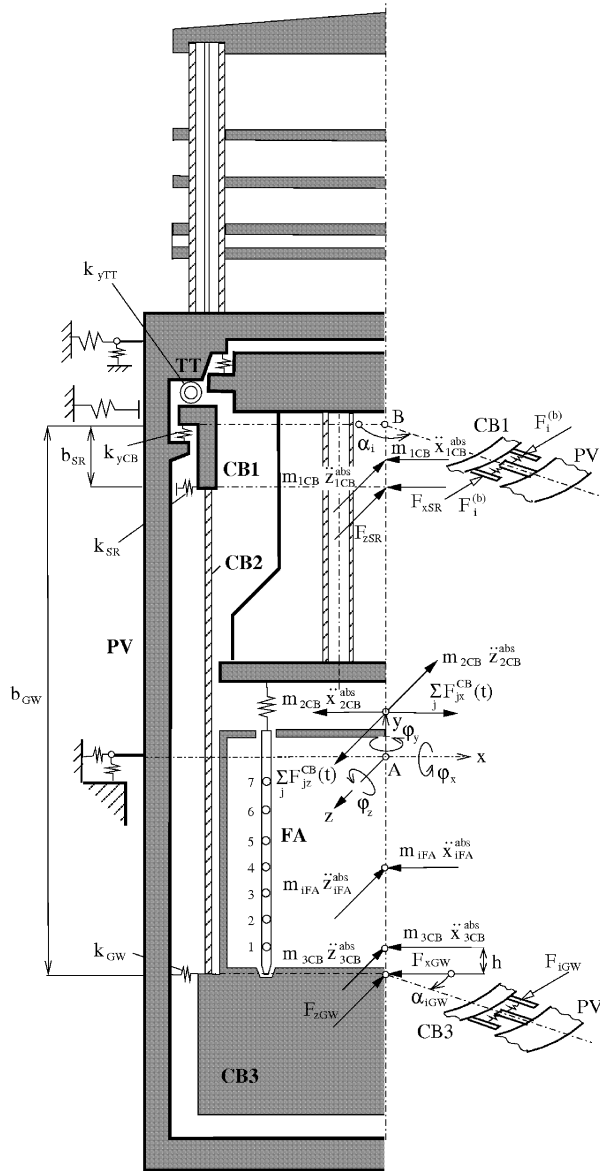

Fig.1: Scheme of the core barrel (CB) and linkages with the pressure vessel (PV)

the slip elimination and a proportional damping the model has the standard form

$$\mathbf{M}\ddot{\mathbf{q}}(t) + \mathbf{B}\dot{\mathbf{q}}(t) + \mathbf{K}\mathbf{q}(t) = \mathbf{f}(t) , \tag{1}$$

where the vector of generalized coordinates of dimension 137 is specified in Table 1 in [3]. The excitation vector  $\mathbf{f}(t)$  can be written as a real part of the complex excitation vector

$$\mathbf{f}(t) = \text{Re} \left\{ \sum_j \sum_k \mathbf{f}_j^{(k)} e^{i k \omega_j t} \right\} , \quad j \in \{1, 2, 3, 4\} , \tag{2}$$

where  $\omega_j$  is a basic angular MCP speed in  $j$ -th loop and  $k$  is a harmonic component of the hydrodynamic force generated by one MCP (Fig. 2). The fluctuation of MCP angular speeds

$\omega_j = \pi n_j/30$ ,  $n_j \in \langle 997.2, 999.6 \rangle$  rpm is based on the measurement at the first and second ETE blocks presented in the research report [5].

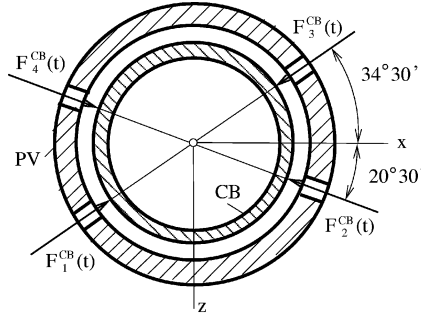

Fig.2: Configuration of the main circulating loops and hydrodynamic forces

The steady dynamic response of the reactor is given by the particular solution

$$\mathbf{q}(t) = \text{Re} \left\{ \sum_j \sum_k \left[ -(k\omega_j)^2 \mathbf{M} + i k \omega_j \mathbf{B} + \mathbf{K} \right]^{-1} \mathbf{f}_j^{(k)} e^{i k \omega_j t} \right\}. \quad (3)$$

The generalized coordinates in dependence on time can be written in the form

$$q_i(t) = \sum_j \sum_k \left( \bar{q}_{i,j}^{(k)} \cos k \omega_j t - \bar{\bar{q}}_{i,j}^{(k)} \sin k \omega_j t \right), \quad (4)$$

where real (with one strip) and imaginary (with two strips) components of complex vector

$$\mathbf{q}_j^{(k)} = \left[ -(k\omega_j)^2 \mathbf{M} + i k \omega_j \mathbf{B} + \mathbf{K} \right]^{-1} \mathbf{f}_j^{(k)}, \quad (5)$$

are introduced. Subscript  $i \in \{1, 2, \dots, 137\}$  is assigned to the generalized coordinate, subscript  $j \in \{1, 2, 3, 4\}$  to the operating MCP and subscript  $k$  to the harmonic component of pressure pulsations.

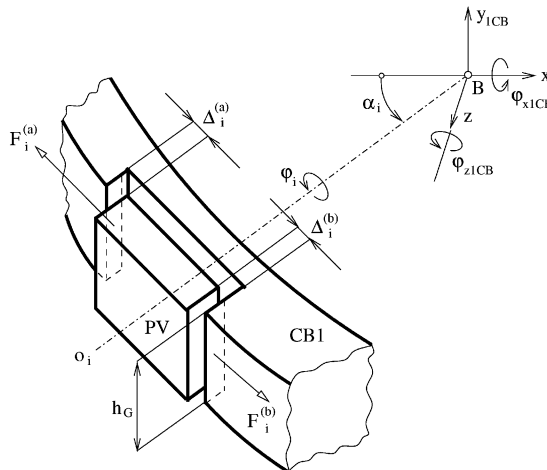

Fig.3: Scheme of the groove and tongue between CB1 and PV flanges

The relative movement of the upper part of core barrel (CB1) related to the pressure vessel (PV), with sufficient friction in contact surfaces of core barrel flange with pressure vessel flange and toroidal tubes (TT) is described by vertical displacement  $y_{1CB}$  and angular displacements  $\varphi_{x1CB}$  and  $\varphi_{z1CB}$  around horizontal axes passing through the point B in centre of the contact annulus (Fig. 3).

The components of the resulting lateral force acting at core barrel (CB1+CB2+CB3) with nuclear fuel assemblies (FA) can be expressed in the form (see Fig. 1 and Fig. 2)

$$\begin{aligned} F_x(t) &= \sum_j F_{jx}^{CB}(t) - F_{xSR}(t) - F_{xGW}(t) - \sum_{i=1}^3 m_{iCB} \ddot{x}_{iCB}^{abs}(t) - \sum_{i=1}^7 m_{iFA} \ddot{x}_{iFA}^{abs}(t), \\ F_z(t) &= \sum_j F_{jz}^{CB}(t) - F_{zSR}(t) - F_{zGW}(t) - \sum_{i=1}^3 m_{iCB} \ddot{z}_{iCB}^{abs}(t) - \sum_{i=1}^7 m_{iFA} \ddot{z}_{iFA}^{abs}(t). \end{aligned} \quad (6)$$

The terms in expressions (6) present the components of hydrodynamic forces, the forces transmitted by a sealing ring (SR) and guide wedges (GW) and components of dynamic inertia forces acting on core barrel parts and nuclear fuel assemblies (FA). All forces with exception of hydrodynamic forces generated by MCP's can be expressed by generalized coordinates (4) and their differentiations with respect to time. The core barrel flange slip is expected if the condition

$$\sqrt{F_x^2(t) + F_z^2(t)} \leq f_B^{ad} N_0 + (f_B^{ad} + f_{TT}^{ad}) F_{TT,0} + (f_{TT}^{ad} k_{yTT} - f_B^{ad} k_{yCB}) y_{1CB}(t) \quad (7)$$

is fulfilled. This condition is correct providing the same coefficients of friction  $f_B^{ad}$  ( $f_{TT}^{ad}$ ) and the same vertical contact stiffnesses in any point of the contact surfaces between CB1 and PV flanges (CB1 flange and toroidal tubes). The CB1 flange is considered as a rigid body, therefore the core barrel flange slip is related to the whole flange. If the condition (7) is satisfied frictional forces in contact surfaces of the core barrel flange are greater than the resulting lateral force acting on the core barrel. This is achieved by sufficiently large coefficients of friction  $f_B^{ad}$ ,  $f_{TT}^{ad}$  of both contact surfaces, vertical static force  $N_0$  transmitted by annulus area in suspension of core barrel (for  $F_{TT,0}$ ) and static pre-stressing of toroidal tubes  $F_{TT,0}$  inserted between the upper flange of the core barrel and the pressure vessel core (Fig. 1). The total vertical contact stiffness  $k_{yCB}$  in the suspension of the core barrel, the vertical toroidal tube stiffness  $k_{yTT}$ , resulting radial sealing ring  $k_{SR}$  and guide wedge  $k_{GW}$  stiffnesses were calculated by FEM.

The critical pre-stressing of toroidal tubes guaranteeing a slip elimination results from condition (7) and is

$$F_{TT \text{ crit}} = \frac{\max_t \left\{ \sqrt{F_x^2(t) + F_z^2(t)} - (f_{TT}^{ad} k_{yTT} - f_B^{ad} k_{yCB}) y_{1CB}(t) \right\} - f_B^{ad} N_0}{f_B^{ad} + f_{TT}^{ad}}. \quad (8)$$

### 3. Modelling of core barrel flange slip

If the condition (7) is not satisfied there is a qualitative change of the reactor motion. The original vector of generalized coordinates  $\mathbf{q}(t)$  is extended in the form

$$\tilde{\mathbf{q}}(t) = [\mathbf{q}^T(t) \ \Delta^T(t)]^T, \quad (9)$$

where components of the subvector  $\Delta = [x \ z]^T$  describe the core barrel flange slip along a pressure vessel flange (see Fig. 3). Because of the slip the original reactor mathematical model (1) is modified into the nonlinear extended form

$$\begin{bmatrix} \mathbf{M} & \mathbf{M}_\Delta \\ \mathbf{M}_\Delta^T & \mathbf{M}_{\Delta\Delta} \end{bmatrix} \begin{bmatrix} \ddot{\mathbf{q}} \\ \ddot{\Delta} \end{bmatrix} + \begin{bmatrix} \mathbf{B} & \mathbf{0} \\ \mathbf{0} & \mathbf{0} \end{bmatrix} \begin{bmatrix} \dot{\mathbf{q}} \\ \dot{\Delta} \end{bmatrix} + \begin{bmatrix} \mathbf{K} & \mathbf{K}_\Delta \\ \mathbf{K}_\Delta^T & \mathbf{K}_{\Delta\Delta} \end{bmatrix} \begin{bmatrix} \mathbf{q} \\ \Delta \end{bmatrix} = \begin{bmatrix} \mathbf{f}(t) \\ \Delta \mathbf{f}(\Delta, \dot{\Delta}, t) \end{bmatrix}. \quad (10)$$

The new block matrices and the nonlinear force subvector  $\Delta \mathbf{f}$  can be derived from Lagrange equations. The core barrel flange slip influences only a formula for kinetic energy of core barrel  $E_k^{(CB)}$  and nuclear fuel assemblies  $E_k^{(FA)}$ . The original expression of reactor potential (deformation) energy is completed with a deformation energy of activated linkages between tongues of the pressure vessel flange and grooves in the core barrel flange (Fig. 3). These twelve linkages are uniformly distributed along a flange circumference with an assembly backlash  $\Delta_i^{(a)}$  and  $\Delta_i^{(b)}$ ,  $i = 1, 2, \dots, 12$ . The tangential stiffness  $k_B$  of the one groove and tongue linkage was calculated in the Nuclear Research Institut Rez plc by FEM and was used for calculation of the tongue a grooves loading in [6].

The deformation energy of the all internal linkages between core barrel and pressure vessel influenced by slip can be expressed in the form

$$\begin{aligned} E_p^{(CB,PV)} &= \frac{1}{2} k_{SR} \left[ (x + b_{SR} \varphi_{z1CB})^2 + \frac{1}{2} (z - b_{SR} \varphi_{x1CB})^2 \right] + \\ &+ \frac{1}{2} k_{GW} \left[ (b_{GW} \varphi_{z1CB} + x_{3CB} + h \varphi_{z3CB} + x)^2 + \right. \\ &\quad \left. + (-b_{GW} \varphi_{x1CB} + z_{3CB} - h \varphi_{x3CB} + z)^2 \right] + \\ &+ \frac{1}{2} k_B \sum_{i=1}^{12} \left( x \sin \alpha_i + z \cos \alpha_i - \Delta_i^{(a)} \right)^2 H \left( x \sin \alpha_i + z \cos \alpha_i - \Delta_i^{(a)} \right) + \\ &+ \frac{1}{2} k_B \sum_{i=1}^{12} \left( -x \sin \alpha_i - z \cos \alpha_i - \Delta_i^{(b)} \right)^2 H \left( -x \sin \alpha_i - z \cos \alpha_i - \Delta_i^{(b)} \right), \end{aligned} \quad (11)$$

where  $H$  is Heaviside function, angles  $\varphi_{x1CB}$  and  $\varphi_{z1CB}$  describe the side tilt angle of the core barrel component CB1 with respect to pressure vessel and  $x_{3CB}$ ,  $z_{3CB}$ ,  $\varphi_{x3CB}$ ,  $\varphi_{z3CB}$  are lateral and angle displacements of the core barrel component CB3 with respect to CB1. A contact of tongue sides with groove sides is activated only when the argument of Heaviside function is positive.

The new block matrices in the extended reactor model (10) are expressed from identity

$$\frac{d}{dt} \frac{\partial \left( E_k^{(CB)} + E_k^{(FA)} \right)}{\partial \dot{\Delta}} + \frac{\partial E_p^{(CB,PV)}}{\partial \Delta} = \mathbf{M}_\Delta^T \ddot{\mathbf{q}} + \mathbf{M}_{\Delta\Delta} \ddot{\Delta} + \mathbf{K}_\Delta^T \mathbf{q} + \mathbf{K}_{\Delta\Delta} \Delta + \mathbf{f}_C(\Delta). \quad (12)$$

The coupling nonlinear force vector in (12) is

$$\mathbf{f}_C(\Delta) = \begin{bmatrix} \sum_{i \in C_a(t)} F_i^{(a)}(x, z) \sin \alpha_i - \sum_{i \in C_b(t)} F_i^{(b)}(x, z) \sin \alpha_i \\ \sum_{i \in C_a(t)} F_i^{(a)}(x, z) \cos \alpha_i - \sum_{i \in C_b(t)} F_i^{(b)}(x, z) \cos \alpha_i \end{bmatrix}, \quad (13)$$

where symbols  $C_a(t)$  and  $C_b(t)$  express the sets of numbers of activated forces

$$\begin{aligned} F_i^{(a)}(x, z) &= k_B \left( x \sin \alpha_i + z \cos \alpha_i - \Delta_i^{(a)} \right), \\ F_i^{(b)}(x, z) &= k_B \left( -x \sin \alpha_i - z \cos \alpha_i - \Delta_i^{(b)} \right) \end{aligned} \quad (14)$$

transmitted by groove and tongue linkages in time  $t$ . The generalized non-conservative forces  $Q_x$  and  $Q_z$  corresponding to new coordinates  $x, z$  are derived from the virtual work of frictional  $T(t)$  and hydrodynamical  $F_j^{CB}(t)$  forces. They have the form

$$\begin{aligned} Q_x &= -\frac{\dot{x}(t)}{\sqrt{\dot{x}^2(t) + \dot{z}^2(t)}} T(t) + \sum_j F_{jx}^{CB}(t), \\ Q_z &= -\frac{\dot{z}(t)}{\sqrt{\dot{x}^2(t) + \dot{z}^2(t)}} T(t) + \sum_j F_{jz}^{CB}(t), \end{aligned} \quad (15)$$

where

$$T(t) = f_B N_0 + (f_B + f_{TT}) F_{TT,0} + (f_{TT} k_{yTT} - f_B k_{yCB}) y_{1CB}(t) \quad (16)$$

is resulting frictional force acting on core barrel flange in the course of the slip and where  $F_{jx}^{CB}(t)$  and  $F_{jz}^{CB}(t)$  are horizontal components of the hydrodynamic force  $F_j^{CB}(t)$  generated by  $j$ -the MCP acting on the core barrel [3].

The resulting nonlinear force subvector in (10) is expressed in accordance with (12) to (16) as

$$\Delta \mathbf{f}(\Delta, \dot{\Delta}, t) = \mathbf{Q}(\dot{\Delta}, t) - \mathbf{f}_C(\Delta), \quad (17)$$

where  $\mathbf{Q}(\dot{\Delta}, t) = [Q_x, Q_z]^T$ .

#### 4. Computer simulation of vibrations and dynamic loading of internal linkages

The extended acceleration vector  $\ddot{\mathbf{q}} = [\ddot{\mathbf{q}}^T, \ddot{\Delta}^T]^T$  results from nonlinear mathematical model (10) in consequence of slip. It is the nonlinear function of generalized coordinates, generalized velocities and explicitly of time  $t$ . The method of constant acceleration in short time intervals  $n \Delta t \leq t \leq (n+1) \Delta t$ ,  $n = 0, 1, 2, \dots$ , was applied. The simulation starts from initial conditions  $\mathbf{q}(0) = \mathbf{0}$ ,  $x(0) = x_0$ ,  $z(0) = z_0$  of reactor statical equilibrium for zero hydrodynamic forces. In each simulation step a condition of slip stop in the form

$$\begin{aligned} \sqrt{\dot{x}^2[(n+1)\Delta t] + \dot{z}^2[(n+1)\Delta t]} &< \varepsilon, \\ \sqrt{\bar{F}_x^2[(n+1)\Delta t] + \bar{F}_z^2[(n+1)\Delta t]} &\leq T[(n+1)\Delta t] \end{aligned} \quad (18)$$

is checked, where  $\varepsilon$  is small velocity parameter and

$$\begin{aligned} \bar{F}_x &= F_x - \sum_{i \in C_a(t)} F_i^{(a)} \sin \alpha_i + \sum_{i \in C_b(t)} F_i^{(b)} \sin \alpha_i - k_{SR} x - k_{GW} x, \\ \bar{F}_z &= F_z - \sum_{i \in C_a(t)} F_i^{(a)} \cos \alpha_i + \sum_{i \in C_b(t)} F_i^{(b)} \cos \alpha_i - k_{SR} z - k_{GW} z \end{aligned} \quad (19)$$

are components of the resulting lateral force acting on core barrel with fuel assemblies in a general position of the core barrel flange. The slip is interrupted as far as the both conditions (18) are fulfilled at the end of time interval.

A maximal lateral pressure at sides of the tongues is given by expression

$$p_{i \max}^{(x)} = \frac{F_i^{(x)}}{A_{\text{ef}}} \pm \frac{k_{\text{B}}}{2 A_{\text{ef}}} h_{\text{G}} \varphi_i, \quad x = \text{a, b}, \quad i = 1, 2, \dots, 12, \quad (20)$$

where  $A_{\text{ef}}$  is the effective contact surface,  $h_{\text{G}}$  is the groove height and  $\varphi_i = \varphi_{z1\text{CB}} \sin \alpha_i - \varphi_{x1\text{CB}} \cos \alpha_i$  is the side tilt angle of the groove in the core barrel flange with respect to tongue around an axis  $o_i$  (see Fig. 3).

## 5. Selected results of simulations

For an assessment of the influence of the slip upon a dynamic loading of core barrel internal linkages some variants of the different configuration of the operating pumps and static pre-stressing of toroidal tubes  $F_{\text{TT},0}$  were considered (see Table 1, detailed in [6]). The following values of amplitudes  $F_{\text{CB}}^{(k)}$  of partial harmonic components of the hydrodynamic force excited by one pump  $F_{\text{CB}}^{(1)} = 0.268 \times 10^6$ ,  $F_{\text{CB}}^{(2)} = 0.290 \times 10^6$ ,  $F_{\text{CB}}^{(3)} = 0.334 \times 10^6$  N [7], rotational frequencies of MCP's  $f_1 = 16.62$ ,  $f_2 = 16.64$ ,  $f_3 = 16.66$ ,  $f_4 = 16.64$  Hz [5] and vertical static force  $N_0$  corresponding to MCP configuration [8], were considered.

MCP configuration	$N_0$ [MN]	$F_{\text{TT},0}$ [MN]	Maximal deformation and loading of the tongues				
			order	time [s]	deform. [ $\mu\text{m}$ ]	$F_{\text{max}}$ [ $10^4$ N]	$p_{\text{max}}$ [MPa]
1+2+3+4	0.275	2	12b	16.1	< 1	< 1	4.0
		1	6a, 12b	20.0	36	6.4	167
		0.5	6a, 12b	21.2	84	15.1	413
1+2+3	0.8801	1	10a, 4b	40.0	23	4.1	133
1+3	1.518	1	12b	18.7	< 1	< 1	3.5

Tab.1: The maximal loaded tongue in time interval  $t \in \langle 0, 40 \rangle$  s and its maximal deformation, transmitted force and lateral pressure

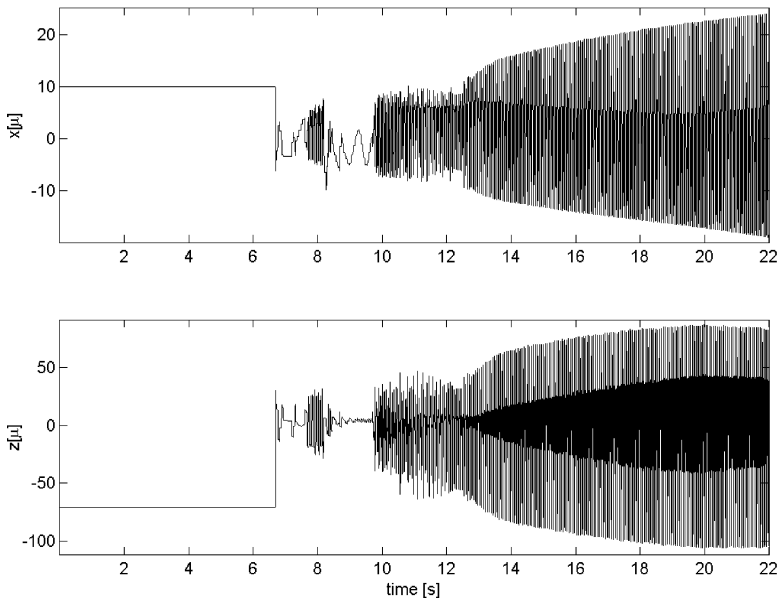

Fig.4: Displacements of core barrel flange slip for all working MCP's, slightly different pump revolutions (see Table 1) and  $F_{\text{TT},0} = 10^6$  N

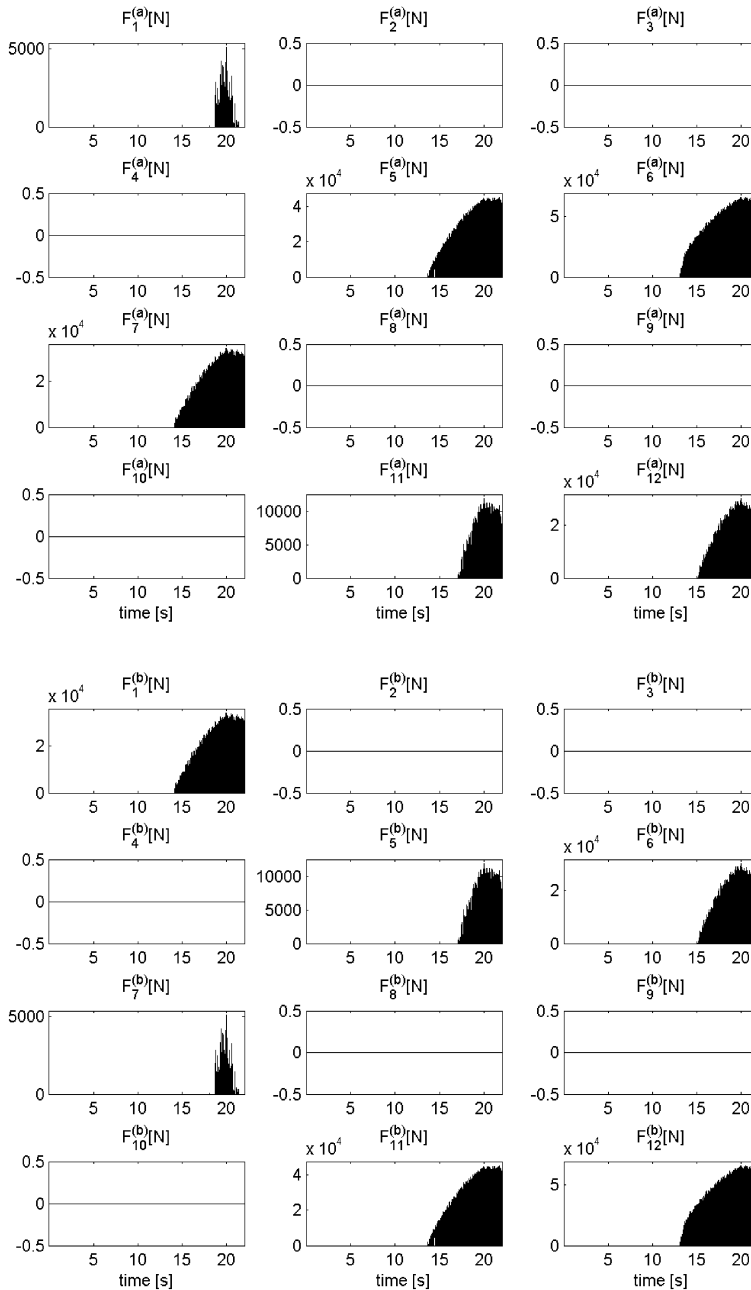

Fig.5: Forces transmitted by single tongue sides (a) and (b) for operational state defined in Fig. 4

The assembly backlash in each tongue and groove is  $\Delta_i^{(a)} = \Delta_i^{(b)} = 73 \mu\text{m}$  and the contact stiffness is  $k_B = 1.8 \times 10^9 \text{ Nm}^{-1}$  [6]. The solid friction in contact surfaces was characterized by coefficient of static friction  $f_B^{\text{ad}} = f_{\text{TT}}^{\text{ad}} = 0.1$  and kinematic friction  $f_B = f_{\text{TT}} = 0.05$ . The time parameter should be changed with a relatively short step  $\Delta t \leq 10^{-4} \text{ s}$ . The eccentric initial position of the core barrel flange in time  $t = 0$ , given by coordinates  $x_0 = 10 \mu\text{m}$



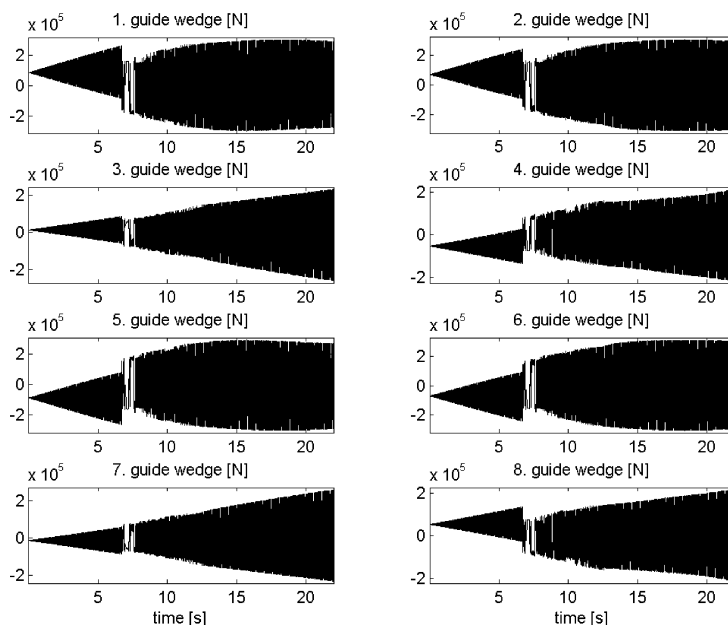

Fig.6: Forces transmitted by single guide wedges in the tangential direction for operational state defined in Fig. 4

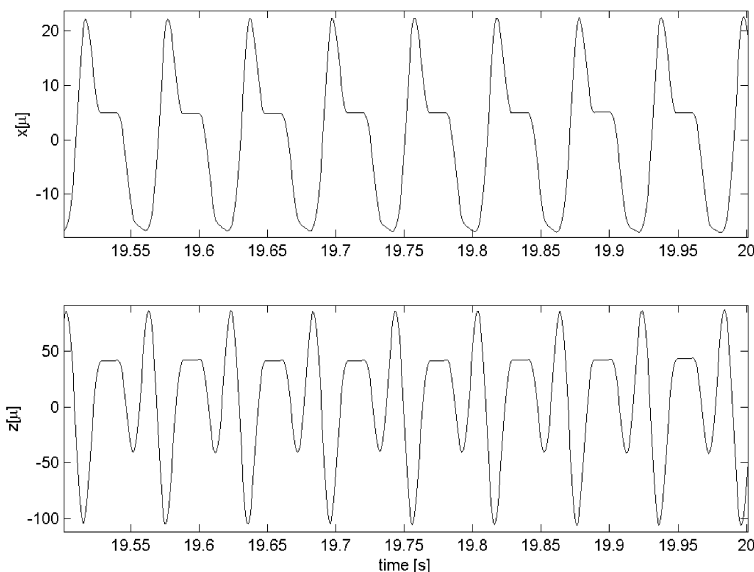

Fig.7: Detailed time course of the CB flange displacements

and  $z_0 = -71.3 \mu\text{m}$ , corresponds to a surface contact of two loadless opposite tongues with grooves. As an illustration time courses in interval  $t \in \langle 0, 22 \rangle\text{s}$  of core barrel flange slip displacements (Fig.4), forces transmitted by single tongue sides (Fig.5) and forces transmitted by single guide wedges (Fig. 6) in the tangential direction for MCP configuration 1+2+3+4 are shown in mentioned figures. In these figures the calculated values are drawn in every tenth step of simulation for operational state characterized by  $N_0 = 0.275 \times 10^6 \text{ N}$  and

$F_{TT,0} = 10^6$  N. The detailed time course of the slip displacements in interval  $t \in \langle 19.5, 20 \rangle$  s, corresponding to maximal dynamic tongue loading, is shown in Fig. 7. Period of time 0.06 s corresponds to middle rotational frequency  $f = 16.64$  Hz of the MCP's.

## 6. Conclusion

The original linear mathematical model of the VVER 1000/320 type reactor presented in the paper [3] was extended by including two more degrees of freedom describing the core barrel flange slip along a pressure vessel flange in the lateral plane. The extended nonlinear model can be used for the determination of the dynamic response of reactor components excited by pressure pulsations generated by main circulation pumps. The software developed in MATLAB makes possible to chose an arbitrary configuration of operating pumps and to simulate the slip with flexible impacts in the groove and tongue type linkages caused by side clearance.

On the basis of series of simulations [6] for different operational conditions – slightly different revolutions of individual main circulation pumps, decreasing of toroidal tubes pre-stressing, different frictional conditions in contact areas of core barrel flange and the like – it is possible to formulate some conclusions:

1. The minimal pre-stressing of toroidal tubes inserted between the upper flange of the core barrel and the pressure vessel cover has to be guaranteed for the slip and impact motion core barrel flange elimination.
2. An eccentric initial position of the core barrel flange with respect to pressure vessel flange within the frame of backlash influences only an initial transient motion but has no influence on maximal forces transmitted by internal linkages of core barrel with pressure vessel.
3. The rest state of core barrel flange at the beginning of simulation changes into oscillatory motion within the frame of backlash and later, in consequence of beat effect, into an impact motion. This state can produce an excessive abrasive wear of the tongues and grooves.
4. The Lagrange equations in the matrix form are an efficient instrument for an amplification of mathematical models of mechanical systems with internal friction linkages activated by slipping.

## Acknowledgement

This work was supported by the research project MSM 4977751303 of the Ministry of Education, Youth and Sports of the Czech Republic.

## References

- [1] Pečínka L., Stulík P.: Experimental verification of reactor WWER 1000/320 response to main circulating pump pressure pulsations. In: Proceedings of the colloquium Dynamics of Machines 2008, Institute of Thermomechanics AS CR, Prague, 2008, pp. 87–94 (in Czech)
- [2] Pečínka L., Krupa V., Klátil J.: Mathematical Modelling of the Propagation of the Pressure Pulsations in the Piping Systems of NPPs, In: Proceedings of the Conf. Computational Mechanics, University of West Bohemia, Pilsen, 1998, pp. 203–210 (in Czech)
- [3] Zeman V., Hlaváč Z.: Dynamic response of VVER 1000 type reactor excited by pressure pulsations, Engineering Mechanics, Vol. 15, 2008, No. 6, p. 435–446

- [4] Zeman V., Hlaváč Z.: Modelling of WWER 1000 type reactor vibration by means of decomposition method. *Engineering Mechanics 2006*, Svratka, pp. 444–445 (full text on CD-ROM)
- [5] Zeman V., Hlaváč Z., Pečínka L.: Dynamic response of VVER 1000/320 type reactor components excited by pressure pulsations generated by main circulation pumps, Report of the University of West Bohemia, No. 52120-02-07, Pilsen, 2007 (in Czech)
- [6] Zeman V., Hlaváč Z.: Calculation of the tongue and grooves loading in the core barrel flange of the VVER 1000 type reactor excited by pressure pulsation, Report No. 52120-04-08, University of West Bohemia, 2008 (in Czech)
- [7] Pečínka L., Hlaváč Z., Zeman V.: Analysis of vibrations and lifetime of internal parts of the reactor WWER 1000, Model 320 of the NPP ETE excited by pressure pulsation generated by main circulation pumps, Report of the NRI Rez, No. 10905T, 1997
- [8] Macák P.: Statical models of an interaction of the reactor pressure vessel, internal parts and nuclear fuel assemblies at a change of the coolant flow project values, Report No. AZ 12447/Dok, ŠKODA Plzeň, Nuclear Machinery, 2008 (in Czech)
- [9] Zeman V., Hlaváč Z.: Dynamic loading of internal linkages of the VVER 1000 type reactor excited by pressure pulsation, In: *Proceedings of the colloquium Dynamics of Machines 2008*, Institute of Thermomechanics AS CR, Prague, 2009, pp. 153–160 (in Czech)

*Received in editor's office:* March 11, 2009

*Approved for publishing:* May 25, 2009

*Note:* This paper is an extended version of the contribution presented at the national colloquium with international participation *Dynamics of Machines 2009* in Prague.