

**International Journal of Innovative Research in Science, Engineering and Technology**

An ISO 3297: 2007 Certified Organization,

Volume 3, Special Issue 1, February 2014

International Conference on Engineering Technology and Science-(ICETS'14)On 10th & 11th February Organized by

Department of CIVIL, CSE, ECE, EEE, MECHANICAL Engg. and S&H of Muthayammal College of Engineering, Rasipuram, Tamilnadu, India

Analysis of Torque and Speed Controller for Five Phase Switched Reluctance Motor

Ramesh Kumar. S¹, Dhivya. S²Assistant Professor, Department of EEE, Vivekananda Institute of Engineering and Technology for women, Tiruchengode, Tamil nadu, India.¹PG Scholar, Department of EEE, Vivekananda Institute of Engineering and Technology for women, Tiruchengode, Tamil nadu, India.²

Abstract—The electric drives play a vital role on the productivity to any industry. The application of Switched Reluctance Motor (SRMs) in high performance industry is due to the progress in the motor design and power electronic control technology. The electromagnetic operation of an SRM is achieved by the proper excitation and control. A SRM is characterized by simple features like simple construction, high reliability and low cost. It can be used in the high temperature and hazardous environment applications. Most switched reluctance motors are either 3 phase or 4 phase types with unipolar or half wave electronic drives. The torque ripple must be carefully minimized with proper commutation of the power to each of the stator phase winding. The design of control system for five phase SRM is very complex since it has large torque ripples and non uniform torque at its output. The reduction in torque ripples and speed control requires an effective controller. In this paper the output obtained using PI controller is shown clearly. Here, simulation of the PI based controller for SRM is performed by using MATLAB/simulink.

Keywords—switched reluctance motor, proportional integral controller (PI), torque ripple.

I. INTRODUCTION

A switched reluctance motor is a brushless AC motor which has simple construction and does not require permanent magnet for its operation. Hence it has many advantages over other dc or ac machines. The stator and rotor in SRM have salient poles and the number of poles

depends on the number of phases. Normally two stator poles at opposite ends are configured to form one phase. The number of stator poles is always different from that of rotor poles. SR motor has the phase winding on its stator and concentrated windings are used. The windings are inserted into the stator poles and connected in series to form one phase of the motor. SR motor has the phase winding on its stator only and concentrated windings are used. The windings are inserted into the stator poles and connected in series to form one phase of the motor. In a five phase SRM there are five pairs of concentrated windings and each pair of the winding is connected in series to form each phase respectively.

The flux linkage, inductance and torque characteristics vary with rotor position (i.e. the relative position of the rotor pole with the stator pole). The flux linkage, inductance and torque characteristics of a SR motor are highly non-linear. Positive torque in a SR motor is available at half the rotor pole pitch.

Torque production in an SR motor can be explained based on energy conversion process. When one phase of the motor is energized, energy from the power supply is transferred to the phase winding. Part of the energy, which is also known as the co-energy, is used to produce mechanical movement. Torque produced in this movement is defined as the ratio of change in co-energy to the change in rotor position. In mathematical expression, the torque production process can be expressed as

$$\text{Torque} = \Delta W / \Delta \theta$$

where W' is co-energy, θ is rotor position.

International Journal of Innovative Research in Science, Engineering and Technology

An ISO 3297: 2007 Certified Organization,

Volume 3, Special Issue 1, February 2014

International Conference on Engineering Technology and Science-(ICETS'14)

On 10th & 11th February Organized by

Department of CIVIL, CSE, ECE, EEE, MECHANICAL Engg. and S&H of Muthayammal College of Engineering, Rasipuram, Tamilnadu, India

coenergy = $\partial y di$ where y is flux linkage, i is phase current.

The popular electronic method for torque ripple reduction is based on the optimization of control principles. This includes the supply voltage, turn-on and turn-off angles of the converter and current levels. But overall torque will be reduced. Precise control of SRM model is not easy using conventional method (like PI) as its flux linkage, inductance, and torque possess mutual coupling with rotor position and phase current. Fuzzy logic is one of the artificial intelligence techniques, but its applications are more recent than other expert systems. It gives smooth output control even for huge variations in input variables. It provides an opening for control system which is normally considered to be not feasible for automation. It can also be hybrid with other algorithms to solve the complex problems. Fuzzy logic has been successfully implemented in modeling, process control and military science. Fuzzy logic controller is the most suitable to design the controller for difficult mathematical model due to nonlinearity and impression.

II. FIVE PHASE 10/8 SR MOTOR

For smooth performance, direction of rotation, good torque ripple and good efficiency motor with five phases is needed. It consists of 8 soft iron salient rotor poles with 10 stator poles, each wound with a concentric coil. Each phase consists of two coils located opposite to one another connected either in series or in parallel.

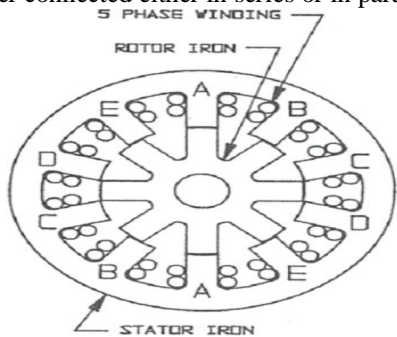

Fig 1 Five phase 10/8 SRM

If the number of phases and the number of poles are higher, then the switching frequency also becomes higher. In this case three phases can be energized at a time and this would increase the average output torque.

The electrical angle is obtained by dividing 360° with the number of phases. Therefore the electrical angle between the phases for 5 phase srm is $360^\circ/5$ which give 72°. This motor produces torque at all rotor position even if one phase is shorted or open. The greater the number of phases with the maximum number of salient rotor poles, the lower the torque ripple.

The following figure shows the torque produced vs. rotor angle for a 3 phase, 4 phase and 5 phase motors. This shows that the torque ripple reduces with increase of phases.

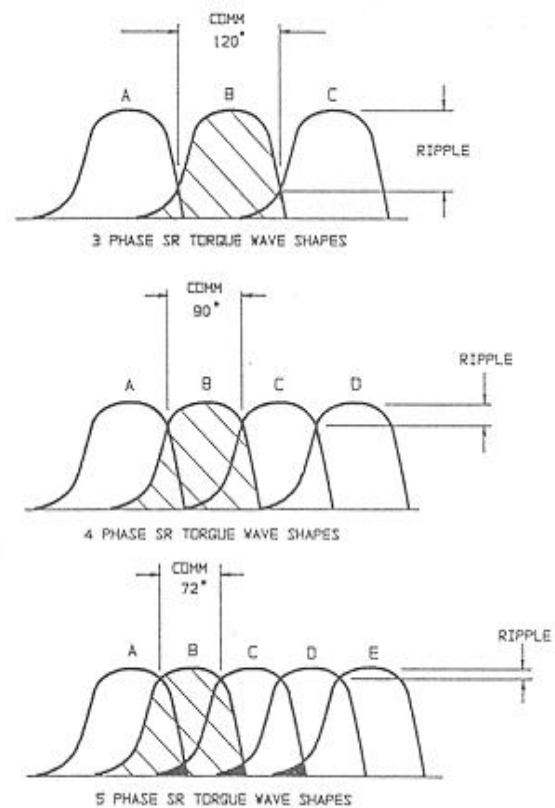

Fig 2 Torque vs. Rotor angle

III. PROPORTIONAL- INTEGRAL (PI) CONTROL

The combination of proportional and integral terms is important to increase the speed of the response and also to eliminate the steady state error.

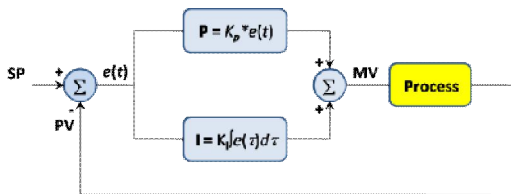

Fig 3 Basic block of a PI controller

controller	Respose time	overshoot	error
On-off	smallest	highest	large
Proportional	small	large	small
Integral	decreases	increases	zero
Derivative	increases	decreases	Small change

The controller output is given by

$$K_p \Delta + K_i \int \Delta dt$$

where Δ is the error or deviation of actual measured value (PV) from the set point (SP).

$$\Delta = SP - PV$$

The Proportional-Integral (PI) algorithm computes and transmits a controller output signal every sample time, T, to the final control element. The computed output from the PI algorithm is influenced by the controller tuning parameters and the controller error (Δ). Integral action enables PI controllers to eliminate offset, a major weakness of a P-only controller. Its function is to integrate or continually sum the controller error.

The proportional term of the PI controller adds or subtracts based on the size of controller error. As error grows or shrinks, the amount added grows or shrinks immediately or proportionately. While the proportional term considers the current size of error only at the time of the controller calculation, the integral term considers the history of the error, or how long and how far the measured process variable has been from the set point over time. Thus the integral action eliminates offset. It continually resets the bias value of controller to eliminate offset as operating level changes.

Tab 1 Comparison of different types of conventional controllers

Thus the PI controller eliminates offset error and increases the speed of the response.

In this case, the flux and speed from the output is given as input to the PI controller through sum and output of PI controller is given as gate signal to each converter which controls the phases of SRM.

The following values are given for PI controller.

$$K_p = 0.00188 \quad K_i = 0.299$$

PI controller is more suitable during steady state and provides robustness to load disturbance.

International Journal of Innovative Research in Science, Engineering and Technology

An ISO 3297: 2007 Certified Organization,

Volume 3, Special Issue 1, February 2014

International Conference on Engineering Technology and Science-(ICETS'14)

On 10th & 11th February Organized by

Department of CIVIL, CSE, ECE, EEE, MECHANICAL Engg. and S&H of Muthayammal College of Engineering, Rasipuram, Tamilnadu, India

IV.SIMULATION DIAGRAM

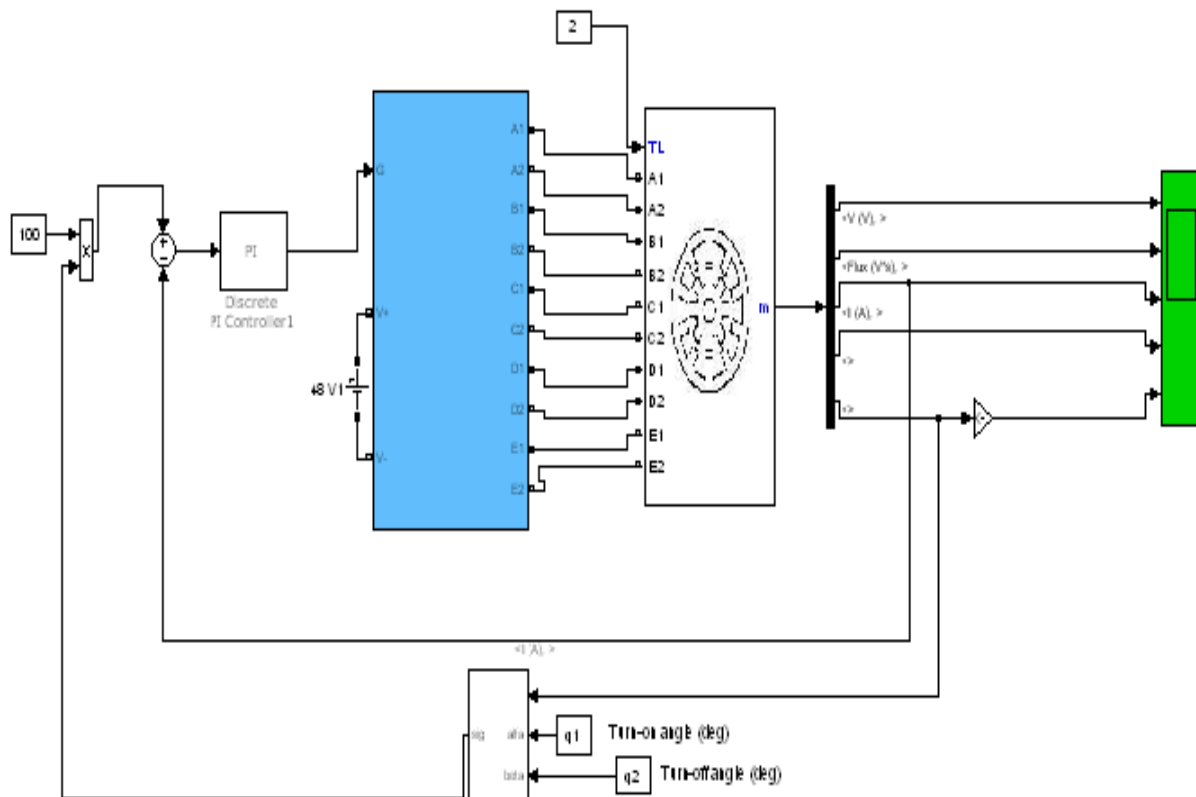

International Journal of Innovative Research in Science, Engineering and Technology

An ISO 3297: 2007 Certified Organization,

Volume 3, Special Issue 1, February 2014

International Conference on Engineering Technology and Science-(ICETS'14)

On 10th & 11th February Organized by

Department of CIVIL, CSE, ECE, EEE, MECHANICAL Engg. and S&H of Muthayammal College of Engineering, Rasipuram, Tamilnadu, India

V.SIMULATION CIRCUIT DIAGRAM OF CONVERTER FOR FIVE PHASES

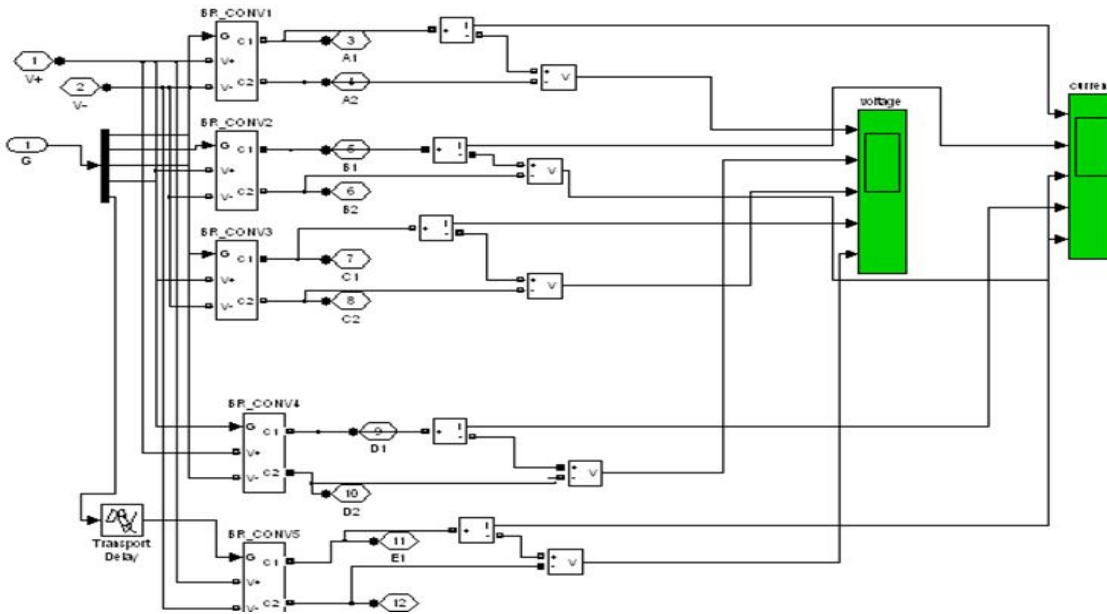

VI.RESULT DISCUSSION

The output obtained for five phase SRM using PI controller is shown below. Single converter is used for each phase and hence totally five converters for five phases. Thus voltage, current and flux for five phases is obtained. Speed and torque waveform for motor is shown in last two graphs.

Speed is controlled by varying the turn on and turn off angle which is given to converter through the PI controller. The tolerance of SRM is small when compared with other motors.

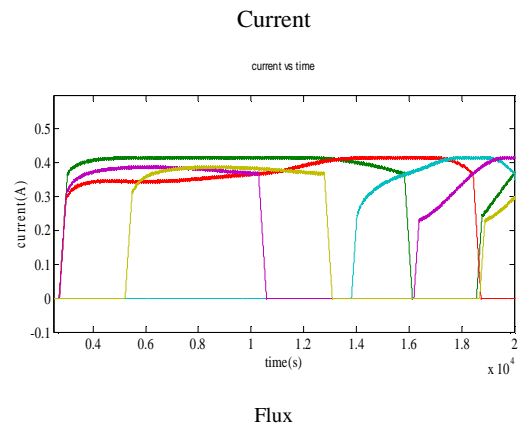
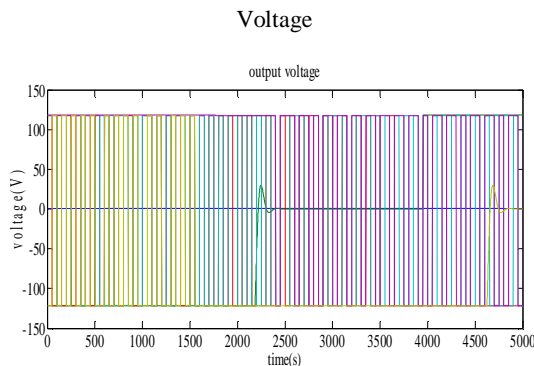

International Journal of Innovative Research in Science, Engineering and Technology

An ISO 3297: 2007 Certified Organization,

Volume 3, Special Issue 1, February 2014

International Conference on Engineering Technology and Science-(ICETS'14)

On 10th & 11th February Organized by

Department of CIVIL, CSE, ECE, EEE, MECHANICAL Engg. and S&H of Muthayammal College of Engineering, Rasipuram, Tamilnadu, India

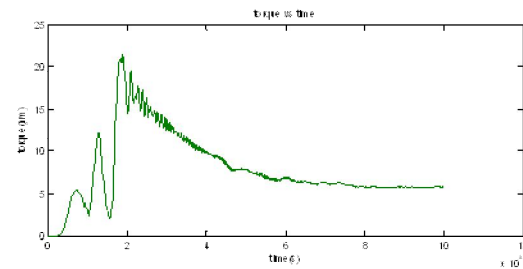

Torque

Speed

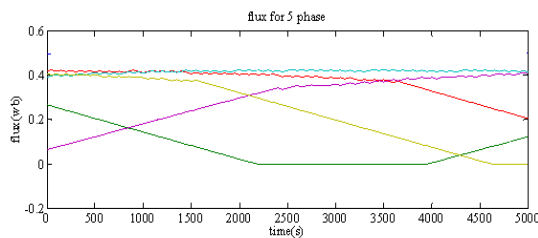

VII.CONCLUSION

In this paper, the torque and speed of five phase SRM is controlled using PI controller. It is clear that the offset error is eliminated and the speed of the response is increased. Thus this five phase motor has more advantages than 3 and 4 phase motors such as the reduction in torque ripple with increase in the number of phases and faster response. In the following study fuzzy logic controller will be applied to the five phase 10/8 SRM for torque and speed control and its performance will be compared with five phase motor performance using PI controller.

REFERENCES

- [1] M. R. Feyzi and Y. Ebrahimi, "Direct torque control of 5-phase 10/8 switched reluctance motors", Iranian Journal of Electrical & Electronic Engineering, Vol. 5, No. 3, Sep. 2009.
- [2] Xu L. and Ruckstadter E., "Direct modeling of switched reluctance machine by coupled field-circuit method", IEEE Trans. Energy Conv., Vol. 10, pp. 446-454, Sep. 1995.
- [3] Nagel N. J. and Lorenz R. D., "Modeling of a saturated switched reluctance motor using an operating point analysis and the unsaturated equation", IEEE Trans. Ind. Applicat., Vol. 36, pp. 714-722, May/June 2000.
- [4] Taylor D. G., "Adaptive control design for a class of doubly-salient motors", in Proc. 30th IEEE Conf. Dec. Cont., Vol. 3, pp. 2903-2908, 1991.
- [5] Nagel N. J. and Lorenz R. D., "Complex rotating vector method for smooth torque control of a saturated switched reluctance motor", in Proc. 34th Annu. Meeting IEEE Ind. Applicat. Vol. 4, pp. 2591-2598, 1999.
- [6] Matsui N., Akao N. and Wakino T., "High-precision torque control of reluctance motor," IEEE Trans. Ind. Applicat., Vol. 27, pp. 902-907, Sep./Oct. 1991.
- [7] Ma B. Y., Liu T. H. and Feng W. S., "Modeling and torque pulsation reduction for a switched reluctance motor drive system", in Proc. IEEE IECON. 22nd Int. Electron. Cont. Instrum., Vol. 1, pp. 72-77, 1996.
- [8] Ilic-Spong M., Marino R., Peresada S. M. and Taylor D. G., "feedback linearizing control of switched reluctance motors", IEEE Trans. Automat. Contr., Vol. AC-32, pp. 371-379, May 1987.
- [9] Wallace R. S. and Taylor D. G., "A balanced commutator for switched reluctance motor to reduce torque ripple", IEEE Trans. Power Electron., Vol. 7, pp. 617-626, July 1992.
- [10] Stankovic A. M., Tadmor G., Coric Z. J. and Agirman I., "On torque ripple reduction in current-fed switched reluctance motors," IEEE Trans. Ind. Electron., Vol. 46, pp. 177-183, Feb. 1999.
- [11] Jinupun P. and Luk P. C. K., "Direct torque control for sensorless switched reluctance motor drives", in Proc. 7th Int. Conf. Power Electron. Variable speed drives, pp. 329-334, 1993.
- [12] Cheok A. D. and Fukuda Y., "A new torque and flux control method for switched reluctance motor drives", IEEE Trans. Power Elect. Vol. 17, pp. 543-557, 2002.