



# Deformation Behaviour Analysis Of Car Wheel Rim Under Different Loading Using Finite Element Method

**M. Sabri, M. Rezal, A. Mu'az, K. Shahril, J.Ihsan**

Universiti Kuala Lumpur Malaysian Spanish Institute, Kulim Hi-Tech Park, 09000, Kedah, Malaysia.

## ABSTRACT

An analysis was conducted to study the deformation behaviour of the car wheel rim when subjected to different loading. This design analysis was performed using SolidWorks and CATIA software. Steel and Alloy are the two types of car wheel rim commonly used in Malaysia. These car wheel rims have been modelled using SolidWorks and follow the manufacturer standard dimension and specification of the car wheel rims. CATIA runs the analysis of the rim models and supports the entire simulation on the rims. Analysis results are presented in the graph of maximum stress and maximum displacement versus speed. It has been found that the Steel wheel rim produced high stress value at 100 km/h speed or at 25 kN loading where the maximum stress is beyond the yield stress limit. Steel wheel rim also deformed twice than the Alloy wheel rim at 25 kN loading. This concludes the Steel wheel rim is highly absorbed loads which is not suitable for its application where the car wheel rim need to be moderately rigid and can withstand with the uneven road condition and potholes. This suggests that the Alloy wheel rim is safer than the Steel wheel rim when subjected to load.

**Keywords:** *Car Wheel Rim, Load, Finite Element Analysis, Stress, Displacement.*

## 1. INTRODUCTION

Crashworthiness characteristics of a vehicle have long been explored to a large extent. Improvement of the safety and the crashworthiness features is a continuous process in the automotive industry. One of the most important development is the force-deflection characteristic of the vehicle. The force-deflection characteristic is correlated to change of momentum or the change of velocity during the impact.

Car wheel rim is also one of the aspect that is being studied, it force-deflection when subjected to crash. Two types of car wheel rim commonly installed in car in Malaysia are the Steel wheel rim and the Alloy wheel rim have been used in this study. Most of the passenger vehicles until nowadays still use Steel wheel rim as standard fitment and Alloy wheel rim as an option. This is due to Alloy wheel rim are more expensive to produce than the Steel wheel rim. Material properties of both types of car wheel rim are different to each other and react differently under same loading. This study mainly focuses on deformation behaviour developed in the car wheel rim in terms of stress distribution and displacement when subjected to different loading. The results will suggest which type of car wheel rim is safer when operating on uneven road or crash in potholes on the road.

## 2. METHODOLOGY

There are two methods were used in this design analysis, which is the reverse engineering and the finite element method. Reverse engineering is the process of discovering the technological principles of a device, object, or system through analysis of its structure, function, and operation [1]. Reverse Engineering has been used to model the car wheel rim in the

SolidWorks software. General dimensions and specifications are obtained from the car wheel rim manufacturer website. Some of the information is not available and are confidential to be published. Alternatively, these confidential dimensions were gained by manual measurement using the measuring tools. The finite element method used to study the deformation behaviour of the car wheel rim that undergoes significant strains and stresses when loads were applied. Analysis was executed using CATIA software. There are 4 main stages involved in this study, which is the data collection, modeling using SolidWorks, analyzing using CATIA and result discussion.

## 3. ANALYSIS

The collected specification and dimension was used to model the car wheel rim in the SolidWorks software. After the modelling part was completed, models were exported into the CATIA to run the analysis. Material properties of each wheel rim components, boundary condition and loads were defined before beginning the analysis. Meshes were generated in the model which it is a part of procedure in doing the analysis using the finite element method. The analysis only can be run after mesh was generated in the model. Results in term of maximum stress distribution and deformation for both types of car wheels rim in different loading can be obtained after the analysis done. Figure 1 and 2 shows the model for both types of car wheel rim imported to CATIA.

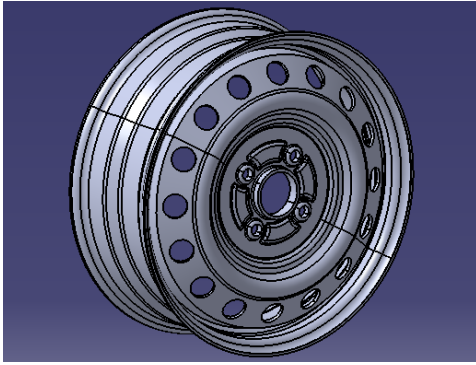

Figure 1: Model of Steel wheel rim in CATIA

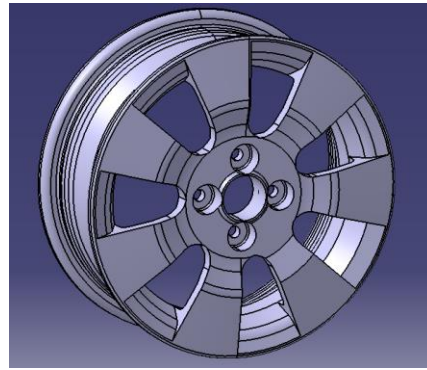

Figure 2: Model of Alloy wheel rim in CATIA

Materials for each component involved in manufacturing the Steel wheel rim and the Alloy wheel rim have been identified based on the literature review and collected information. Steel wheel rim was made from Carbon Steel and Alloy wheel rim was made from Aluminium Alloy. Table 1 shows the material properties for the Carbon Steel and Aluminium Alloy which need to be setup in CATIA software.

Table 1: Materials mechanical properties [2]

Properties	Carbon Steel	Aluminium Alloy
Density	7.85 mg/m <sup>3</sup>	2.8 mg/m <sup>3</sup>
Young's Modulus	200 GPa	73.1 GPa
Poisson Ratio	0.266	0.33
Yield Stress	250 MPa	505 MPa

The car wheel rim was subjected to the load. The load is according to the vehicle cruising speed. Formulas to convert

the vehicle cruising speed into the load,  $F$  is shown in Equation 1.

$$\text{Load, } F = ma \tag{1}$$

$$\text{Acceleration, } a = \frac{V_1 - V_0}{t} \tag{2}$$

Where time,  $t = 0.5$  s (assume crash occurs in between 0 to 1 s), acceleration (gravity),  $a = 9.81$  m/s<sup>2</sup>, initial velocity,  $V_0 = 2$  m/s, striker mass,  $m = 485$  kg and cruising velocity (speed before a crash occurs),  $V_1$ . The striker mass,  $m$  and initial velocity,  $V_0$  were taken from the works done by Chia-Lung Chang which is conducting simulation wheel impact test in his project [3]. Table 2 shows data of vehicle cruising speed converted to the load using the above formulas. Figure 3 and 4 shows the point of applied load at the both types of car wheel rim models.

Table 2: Load due to vehicle cruising speed

Cruising Speed, $V$ (km/h)	Load, $F$ (N)
20	3453.2
40	8836.7
60	14229.9
80	19613.4
100	25006.6

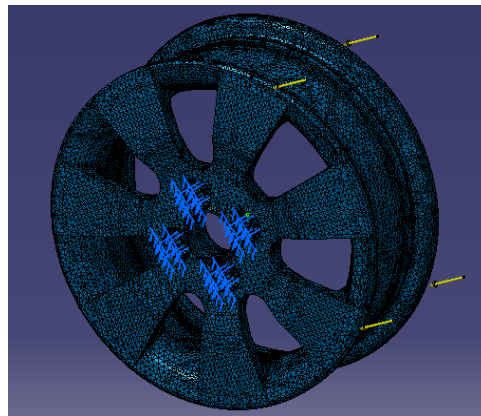
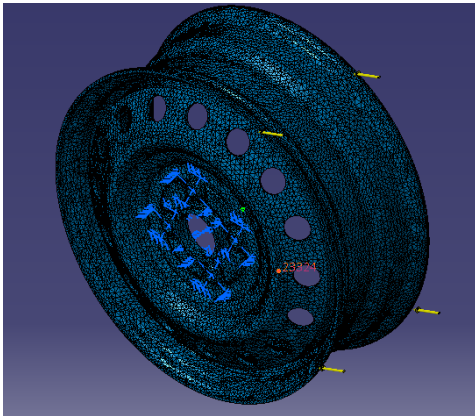
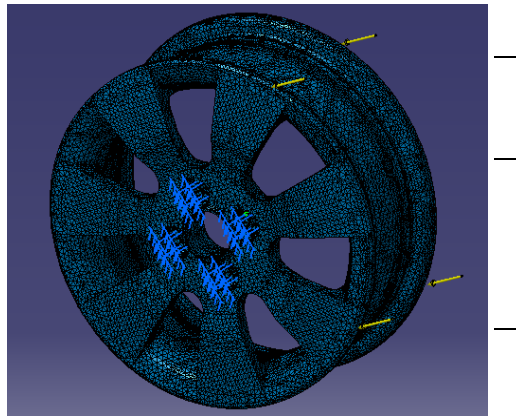

Figure 3: Load applied at Steel wheel rim

Figure 4: Load applied at Alloy wheel rim

#### 4. RESULTS AND DISCUSSIONS

The deformation of Steel wheel rim and Alloy wheel rim can be observed through the analysis done. Both rims deform about the point of loading, as the loads increased, the rims would deform more. This is consistent with the result from J.

Stearns state that stress and the displacement increase with the drop of tyre inflation pressure where the ideal tyre inflation pressure helps to restraints the wheel in its circular geometry [4]. Results are presented in plotting graph of maximum stress versus speed and maximum displacement versus speed.

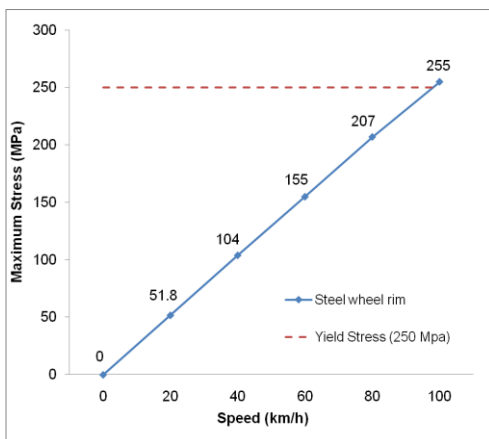

Figure 5: Maximum stress versus speed for Steel wheel rim

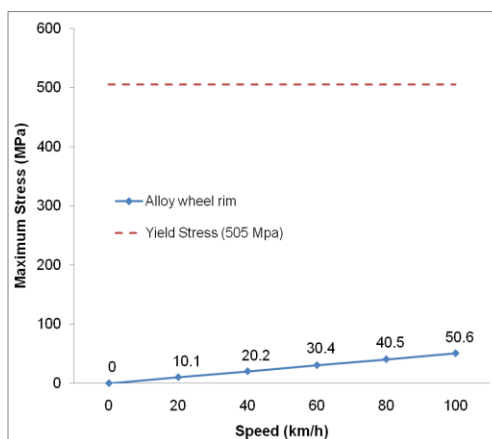

Figure 6: Maximum stress versus speed for Alloy wheel rim

Figure 5 shows the maximum stress distribution for Steel wheel rim when subjected to different vehicle cruising speed increase rapidly from 0 to 255 MPa. Figure 6 shows the maximum stress distribution for Alloy wheel rim which is increased slightly from 0 to 50.6 MPa when compared to the

Steel wheel rim. It can be observed from the graph in Figure 5 that the Steel wheel rim has higher stress compared to Alloy wheel rim at the same speed. In fact, Steel wheel rim has been stressed up to 255 MPa and over the yield stress limit of carbon steel when subjected to vehicle cruising speed of 100

km/h or 25006.6 N. Alloy wheel rim stress value at the same speed still far from the yield stress. It shows Steel wheel rim

is weaker and Alloy wheel rim can withstand bigger loads than the Steel wheel rim.

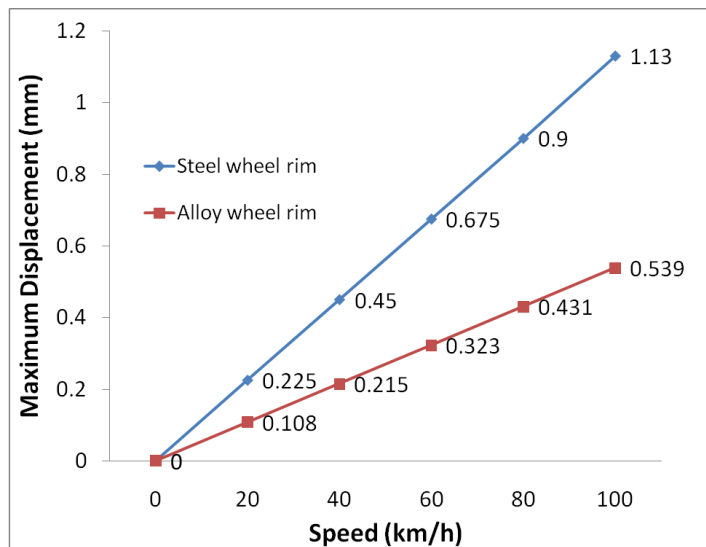

Figure 7: Maximum displacement versus vehicle cruising speed graph for both types of wheel rims

Figure 7 shows the maximum displacement versus vehicle cruising speed graph for both types of wheel rims. It can be observed that the Steel wheel rim has a higher displacement compared to Alloy wheel rim. This also showed that Steel wheel rim is more deform compared to the Alloy wheel rim. Steel wheel rim is fully made from carbon steel and its behaviour is ductile. It explained why the Steel wheel rim deforms twice than the Alloy wheel rim at the same load or speed.

## 5. CONCLUSIONS

The Steel wheel rim has been found to have higher stress and higher displacement compared to Alloy wheel rim when subjected to the same load or speed. Hence, the Steel wheel rim is weaker than the Alloy wheel rim. It is not suggested for car wheel rim application since the car wheel rim should be moderately rigid to withstand the external force during operating on uneven road or during the crash in potholes. It suggests that the Alloy wheel rim has the ability to protect the tyre assembly parts from severe damage or broken which may lead to serious consequences such as car lost control and crash. This was supported by the result in term of displacement where the steel wheel rim deforms twice than the Alloy wheel rim. Finally, the Alloy wheel rim is suggested to be more reliable and safer than the Steel wheel rim.

## ACKNOWLEDGEMENT

The authors would like to thank Universiti Kuala Lumpur for providing the financial support.

## REFERENCES

- [1] Eilam, Eldad & Chikofsky, Elliot J., (2007). "Reversing: secrets of reverse engineering", John Wiley & Sons. p. 3. ISBN 9780764574818.
- [2] ASM Material Data Sheet. <http://asm.matweb.com/search/SpecificMaterial>. (Accessed on November 2011).
- [3] Chia-Lung Chang, Shao-Huei Yang, (2009). Simulation of wheel impact test using finite element method. Engineering Failure Analysis, pp 1711-1719(6).
- [4] J. Stearns, T.S. Srivatsan, A. Prakash, P.C. Lam, (2004). Modeling the mechanical response of an aluminum alloy automotive rim. Material Science and Engineering, pp.262-268(7).