

Optimal Robot Excitation and Identification

Jan Swevers, Chris Ganseman, Dilek Bilgin Tükel, Joris De Schutter, *Member, IEEE*,
and Hendrik Van Brussel, *Fellow, IEEE*

Abstract—This paper discusses experimental robot identification based on a statistical framework. It presents a new approach toward the design of optimal robot excitation trajectories, and formulates the maximum-likelihood estimation of dynamic robot model parameters. The differences between the new design approach and the existing approaches lie in the parameterization of the excitation trajectory and in the optimization criterion. The excitation trajectory for each joint is a finite Fourier series. This approach guarantees periodic excitation which is advantageous because it allows: 1) time-domain data averaging; 2) estimation of the characteristics of the measurement noise, which is valuable in case of maximum-likelihood parameter estimation. In addition, the use of finite Fourier series allows calculation of the joint velocities and accelerations in an analytic way from the measured position response, and allows specification of the bandwidth of the excitation trajectories. The optimization criterion is the uncertainty on the estimated parameters or a lower bound for it, instead of the often used condition of the parameter estimation problem. Simulations show that this criterion yields parameter estimates with smaller uncertainty bounds than trajectories optimized according to the classical criterion. Experiments on an industrial robot show that the presented trajectory design and maximum-likelihood parameter estimation approaches complement each other to make a practicable robot identification technique which yields accurate robot models.

Index Terms—Identification, optimal excitation, robot dynamics.

I. INTRODUCTION

THE KEY aspects in competitive manufacturing today are quality, costs, and time. In this respect, off-line programming supported by simulation, and accurate motion control have become necessary. Accurate robot control and realistic robot simulation require an accurate dynamic robot model. The design of an advanced robot controller, such as a computed torque or a computed velocity controller is based on the robot model, and its performance depends directly on the model accuracy. Robot simulation without dynamic robot model cannot provide realistic execution time estimates, e.g., in the case of spot welding operations, where the time required

to stop the robot end effector at the different spot welding places depends on the robot dynamics.

Experimental robot identification is the only efficient way to obtain accurate robot models as well as indications on their accuracy, confidence and validity. The dynamic model parameters provided by robot manufacturers are insufficient, inaccurate, or often nonexistent, especially those dealing with friction and compliance characteristics. Direct measurement of the physical parameters is unrealistic, because of the complexity of most robots.

Experimental robot identification deals with the problem of estimating the robot model parameters from the response measured during a robot experiment. It is well recognized that reliable, accurate, and efficient robot identification requires **specially designed experiments**. When designing an identification experiment for a robot manipulator, it is essential to consider whether the excitation is sufficient to provide accurate and fast parameter estimation in the presence of disturbances such as measurement noise and actuator disturbances. Most papers related to experimental robot identification measure the influence of these disturbances on the parameter estimates by the condition (number) [1] of the set of equations that generate the parameters [2]–[4], and use this condition number as the criterion for the optimization of the excitation. This criterion is appropriate in a deterministic framework. This paper approaches the excitation-trajectory optimization (and the parameter estimation) within a stochastic (errors-in-variables) framework.

Consistent **parameter estimation** requires accounting for the statistical properties of the measurement noise. *Errors-in-variables* estimation methods consider random disturbances on both input and output measurements [5]. Several of these methods exist [6]–[8], though only few of them have been applied to the estimation of dynamic robot parameters: Xi applies the *total least square (TLS)* parameter estimation method to the identification of the robot inertial parameters [9]. The TLS estimate is consistent if the covariance matrix of the noise (disturbances) on the elements of the regression matrix describing the equation errors is proportional to the identity matrix [6]. This is not the case in the application of Xi [9] because of the structure of the regression matrix. The *generalized total least squares (GTLS)* method, which allows correlations between the noise on the elements of the regression matrix, should be used instead, provided that all errors are random variables and that the covariance matrix can be calculated. The nonlinear dependency of the regression matrix on the joint angle measurements makes the calculation of the required covariance matrix very

Manuscript received October 23, 1995; revised July 24, 1996. This paper was recommended for publication by Associate Editor J. C. Trinkle and Editor S. Salcudean upon evaluation of the reviewers' comments.

J. Swevers is with the Fund for Scientific Research, Flanders, Division of Production, Machine Design and Automation (PMA), Department of Mechanical Engineering, Katholieke Universiteit Leuven, Celestijnenlaan 300 B, B 3001 Heverlee, Belgium (e-mail: Jan.Swevers@mech.kuleuven.ac.be).

C. Ganseman, J. De Schutter, H. Van Brussel are with the Division of Production, Machine Design and Automation (PMA), Department of Mechanical Engineering, Katholieke Universiteit Leuven, Celestijnenlaan 300 B, B 3001 Heverlee, Belgium.

D. Bilgin Tükel is with the Altinay Robotics and Automation Company, Istanbul, Turkey.

Publisher Item Identifier S 1042-296X(97)07145-0.

difficult, if not impossible. The *maximum-likelihood estimator* is a consistent estimator even if the models are nonlinear in the parameters and measurements, which occurs for example if complicated nonlinear friction models are included in the robot model. This method is therefore preferred to the TLS or the GTLS method.

This paper (1) formulates the maximum-likelihood estimation (MLE) of robot model parameters (Section II), (2) presents a new approach toward the design of optimal robot excitation trajectories (Section III), and (3) discusses the application of the presented techniques for the experimental identification of the first three axes of a KUKA IR 361 industrial robot (Section V). Section IV shows, by means of simulations, that the maximum-likelihood parameter estimator, is (asymptotically) efficient and unbiased, and that the proposed trajectory optimization criterion yields parameter estimates with smaller uncertainty bounds than robot excitation optimized through minimization of the condition number.

II. ESTIMATION OF THE ROBOT PARAMETERS

The dynamic model of an n -degree-of-freedom rigid robot is linear in the friction coefficients and the parameters of the mass distribution if they are combined in the so called barycentric parameters [10]. After model reduction [11], the dynamic robot model can be written as a minimal set of linear equations

$$\Phi(\mathbf{q}, \dot{\mathbf{q}}, \ddot{\mathbf{q}})\boldsymbol{\theta} = \boldsymbol{\tau}. \quad (1)$$

\mathbf{q} is the n -vector of the joint angles. $\boldsymbol{\tau}$ is the n -vector of actuator torques. $\Phi(\mathbf{q}, \dot{\mathbf{q}}, \ddot{\mathbf{q}})$ is the $n \times r$ regression matrix, depending on the joint angles, velocities, and accelerations. r is the number of independent robot parameters. $\boldsymbol{\theta}$ is the r -vector containing the unknown barycentric parameters and friction coefficients.

Robot identification deals with the problem of estimating the model parameters $\boldsymbol{\theta}$ [(1)] from the data measured during a robot excitation experiment. In most cases, the data are sequences of joint angles and motor currents, from which a sequence of joint velocities, accelerations, and motor torques are calculated. Actuator torques are assumed to be proportional to the actuator current.

In system identification based on a statistical framework, it is common to assume that the measured joint angles $\mathbf{q}_m(k)$ and actuator torques $\boldsymbol{\tau}_m(k)$, for $k = 1$ to N , are corrupted by independent zero-mean Gaussian noise $\mathbf{n}_q(k), \mathbf{n}_\tau(k)$, i.e.,

$$\begin{aligned} \mathbf{q}_m(k) &= \mathbf{q}(k) + \mathbf{n}_q(k) \\ \boldsymbol{\tau}_m(k) &= \boldsymbol{\tau}(k) + \mathbf{n}_\tau(k). \end{aligned} \quad (2)$$

The noise-free joint angles $\mathbf{q}(k)$ and actuator torques $\boldsymbol{\tau}(k)$ satisfy (1).

Remark 1: Considering a linear relation between the motor current and torque is a first order approximation, which may result in modeling errors. Extension of the robot model with a model describing the relation between the motor torque and the motor current eliminates these modeling errors, and yields

a robot model to which the trajectory design and maximum-likelihood estimation methods which are presented below, are still applicable.

Remark 2: Kinematic errors are deterministic and result in systematic modeling errors and biased parameter estimates if the joint angle measurements are not corrected using a kinematic error-model. It is assumed that these errors are not significant, or are compensated for. Inclusion of these (systematic) errors in $\mathbf{n}_q(k)$ [(2)] is not appropriate, because the maximum-likelihood parameter estimation method described below cannot account for systematic measurement errors since it assumes random disturbances.

A. Maximum-Likelihood Parameter Estimation

This section formulates the maximum-likelihood estimation of **dynamical** robot parameters, which is similar to the maximum-likelihood estimation of **geometrical** robot parameters used for kinematic robot calibration and presented in [12]–[14].

The maximum-likelihood estimate $\boldsymbol{\theta}_{ml}$ of the parameter vector $\boldsymbol{\theta}$ is given by the value of $\boldsymbol{\theta}$ which maximizes the likelihood of the measurement $\mathbf{q}_m(k)$ and $\boldsymbol{\tau}_m(k)$, for $k = 1$ to N . Since the noise on the different measurements is independent and Gaussian, this corresponds to minimizing the following quadratic cost function [12], [13], [15]:

$$K(\mathbf{q}_m, \boldsymbol{\tau}_m | \boldsymbol{\theta}) = \frac{1}{2} \sum_{k=1}^N \sum_{i=1}^n \left(\frac{n_{q_i}^2(k)}{\sigma_{q_i}^2} + \frac{n_{\tau_i}^2(k)}{\sigma_{\tau_i}^2} \right) \quad (3)$$

with $n_{q_i}(k)$ the noise on the measured joint angle $q_i(k)$, and $n_{\tau_i}(k)$ the noise on the measured actuator torque $\tau_i(k)$. $\sigma_{q_i}^2$ and $\sigma_{\tau_i}^2$ are their corresponding variances. It is assumed that these variances are constant and known.

The minimization of criterion (3), taking into account (1), is a nonlinear least squares optimization problem. Its practical implementation requires that $\mathbf{n}_q(k)$ and $\mathbf{n}_\tau(k)$ be calculated for every estimate of $\boldsymbol{\theta}$ given the measured data $\mathbf{q}_m(k)$ and $\boldsymbol{\tau}_m(k)$. This is not possible with the present formulation, since the joint angles $\mathbf{q}(k)$ and actuator torques $\boldsymbol{\tau}(k)$ can not be calculated based on the knowledge of $\boldsymbol{\theta}$ only. The parameter vector $\boldsymbol{\theta}$, i.e., the degrees of freedom of the maximum-likelihood optimization problem, has to be extended with a trajectory parameterization $\boldsymbol{\delta}$: $\mathbf{q}(\boldsymbol{\delta}, k)$, $\dot{\mathbf{q}}(\boldsymbol{\delta}, k)$, and $\ddot{\mathbf{q}}(\boldsymbol{\delta}, k)$. This parameterization is related to the optimization of the robot excitation, and is discussed in Section III. It allows reformulation of the maximum-likelihood criterion (3) as follows:

$$K(\mathbf{q}_m, \boldsymbol{\tau}_m | \boldsymbol{\theta}) = \frac{1}{2} \sum_{k=1}^N \sum_{i=1}^n \left(\frac{(e_q(\boldsymbol{\delta}, k))^2}{\sigma_{q_i}^2} + \frac{(e_\tau(\boldsymbol{\theta}, k))^2}{\sigma_{\tau_i}^2} \right) \quad (4)$$

with

$$\begin{aligned} e_q(\boldsymbol{\delta}, k) &= q_{mi}(k) - q_i(\boldsymbol{\delta}, k) \\ e_\tau(\boldsymbol{\theta}, k) &= \tau_{mi}(k) - \tau_i(\boldsymbol{\theta}, k) \end{aligned}$$

and $\tau_i(\boldsymbol{\vartheta}, k)$ the i th element of

$$\boldsymbol{\tau}(\boldsymbol{\vartheta}, k) = \Psi(\boldsymbol{q}(\boldsymbol{\delta}, k), \dot{\boldsymbol{q}}(\boldsymbol{\delta}, k), \ddot{\boldsymbol{q}}(\boldsymbol{\delta}, k))\boldsymbol{\theta}$$

and

$$\boldsymbol{\vartheta} = [\boldsymbol{\theta}^t \quad \boldsymbol{\delta}^t]^t. \quad (5)$$

This quadratic criterion has to be minimized in $\boldsymbol{\vartheta}$ for a given sequence of measured joint angles $\boldsymbol{q}_m(k)$ and actuator torques $\boldsymbol{\tau}_m(k)$. This minimization can be performed using the Gauss–Newton or the Levenberg–Marquardt method.

The MLE is invariant with respect to parameter vector scaling and consequently data scaling, consistent, asymptotically unbiased, and asymptotically efficient [7], [15], i.e., the covariance matrix of the MLE converges asymptotically to

$$\boldsymbol{C}_p = \boldsymbol{F}\boldsymbol{i}^{-1}$$

with

$$\begin{aligned} \boldsymbol{F}\boldsymbol{i} &= E \left\{ \frac{\partial K(\boldsymbol{y}_m|\boldsymbol{\vartheta})^t}{\partial \boldsymbol{\vartheta}} \frac{\partial K(\boldsymbol{y}_m|\boldsymbol{\vartheta})}{\partial \boldsymbol{\vartheta}} \bigg|_{\boldsymbol{\vartheta}=\hat{\boldsymbol{\vartheta}}} \right\} \\ &= \frac{\partial K(\boldsymbol{y}|\boldsymbol{\vartheta})^t}{\partial \boldsymbol{\vartheta}} \frac{\partial K(\boldsymbol{y}|\boldsymbol{\vartheta})}{\partial \boldsymbol{\vartheta}} \bigg|_{\boldsymbol{\vartheta}=\hat{\boldsymbol{\vartheta}}} \end{aligned} \quad (6)$$

where \boldsymbol{y}_m and \boldsymbol{y} represent the measured and exact data, respectively, $\hat{\boldsymbol{\vartheta}}$ represents the MLE of $\boldsymbol{\vartheta}$. This bound for the covariance matrix is called the *Cramér–Rao lower bound*. $\boldsymbol{F}\boldsymbol{i}$ is called the *Fisher information matrix*. It is a measure of the amount of information present in the measurements in relation to the parameters. This means that the uncertainty on the parameter estimates decreases if there is more information available from the measurements.

This suggests an appropriate design criterion for robot excitation trajectories: design a robot excitation trajectory which “maximizes” the Fisher information matrix. This minimizes the theoretical lower bound on the uncertainty of the parameter estimates, which can be reached asymptotically if the parameters are estimated with the maximum-likelihood estimator.

B. Linear Least Squares Parameter Estimation

The maximum-likelihood parameter estimation simplifies significantly if the measured joint angles are free of noise. This assumption can be justified by the fact that the noise level on the joint angle measurements is much smaller than the noise level on the actuator torque measurements. Under this assumption, the trajectory parameter vector $\boldsymbol{\delta}$ disappears from the minimization criterion (3) and the MLE reduces to the *weighted linear least squares estimate* for which the weighting function is the reciprocal of the standard deviation of the noise on the measured actuator torque values [7], [14], [15]:

$$\begin{aligned} \boldsymbol{\theta}_{ml} &= (\boldsymbol{F}^t \boldsymbol{\Sigma}^{-1} \boldsymbol{F})^{-1} \boldsymbol{F}^t \boldsymbol{\Sigma}^{-1} \boldsymbol{b} \\ &= (\boldsymbol{\Sigma}^{-0.5} \boldsymbol{F})^+ \boldsymbol{\Sigma}^{-0.5} \boldsymbol{b} \end{aligned} \quad (7)$$

with

$$\boldsymbol{F} = \begin{bmatrix} \Phi(\boldsymbol{q}_m(1), \dot{\boldsymbol{q}}_m(1), \ddot{\boldsymbol{q}}_m(1)) \\ \vdots \\ \Phi(\boldsymbol{q}_m(N), \dot{\boldsymbol{q}}_m(N), \ddot{\boldsymbol{q}}_m(N)) \end{bmatrix}$$

and

$$\boldsymbol{b} = \begin{bmatrix} \tau_m(1) \\ \vdots \\ \tau_m(N) \end{bmatrix} \quad (8)$$

and $\boldsymbol{\Sigma}$ is the diagonal covariance matrix of the measured actuator torques. The covariance matrix of the MLE $\boldsymbol{\theta}_{ml}$ is equal to

$$(\boldsymbol{F}^t \boldsymbol{\Sigma}^{-1} \boldsymbol{F})^{-1}. \quad (9)$$

If noise on all actuator torque measurements has the same standard deviation, the maximum-likelihood estimation reduces to the *standard linear least squares estimation*

$$\boldsymbol{\theta}_{ls} = \boldsymbol{F}^+ \boldsymbol{b} = (\boldsymbol{F}^t \boldsymbol{F})^{-1} \boldsymbol{F}^t \boldsymbol{b}. \quad (10)$$

Application of the standard linear least squares method if the above-mentioned assumption of equal standard deviation is not satisfied, corresponds to ignoring the statistical properties of the disturbances, i.e., approaching the parameter estimation within a deterministic framework rather than the statistical (errors-in-variables) framework within which the maximum-likelihood estimation approach is formulated. The condition number of matrix \boldsymbol{F} is a measure for the sensitivity of the least squares solution $\boldsymbol{\theta}_{ls}$ (10) to perturbations on the elements of \boldsymbol{F} and \boldsymbol{b} , provided that the matrix is well equilibrated [1], [3]. The normalization of matrix \boldsymbol{F} , i.e., the division of the columns of \boldsymbol{F} by their norm, takes care of the equilibration and in addition improves the condition number. Consequently it is better to estimate the model parameters using the normalized \boldsymbol{F} matrix and rescale the estimated model parameters afterwards. The condition number of the normalized \boldsymbol{F} matrix is therefore an appropriate trajectory design criterion in the deterministic framework.

III. GENERATION OF OPTIMAL ROBOT EXCITATION TRAJECTORIES

The generation of an optimal robot excitation trajectory involves nonlinear optimization with motion constraints (i.e., constraints on joint angles, velocities, and accelerations, and on the robot end effector position in the cartesian space in order to avoid collision with the environment and with itself). Several approaches have been presented. They all use a different trajectory parameterization. These parameters are the degrees of freedom of the optimization problem. Armstrong [16] describes an approach in which the degrees of freedom are the points of a sequence of joint accelerations. This approach is the most general one, but it results in a large number of degrees of freedom, such that optimization is cumbersome. The optimization is done by maximizing the minimum singular value of the matrix $\boldsymbol{F}^t \boldsymbol{F}$ [(8)]. Gautier [2], [3] optimizes a linear combination of the condition number and the equilibrium of the set of equations that generate the parameters, i.e., of matrix \boldsymbol{F} . The degrees of freedom are a finite set of joint angles and velocities separated in time. The actual trajectory is continuous and smooth, and is calculated by

interpolating a fifth-order polynomial between the optimized points, assuming zero initial and final acceleration. Only a very small part, namely the finite set of joint angles and velocities, of the final trajectory is optimized. As a result, the total smooth trajectory cannot be guaranteed to satisfy all motion constraints nor to be optimal with respect to the condition number or the covariance matrix criterion. Adjusting the trajectory to fit the motion constraints involves trial-and-error and is hardly discussed in [2] and [3]. The practicability of this trajectory design approach is therefore questionable. Otani [4] uses trajectories which are a combination of a cosine and a ramp, such that the joint velocities change sinusoidally between zero and their maximum value. The degrees of freedom are the frequency and amplitude of the sinusoidal movements for each joint, together with the initial robot configuration. The optimization criterion is the minimization of the condition number of matrix $\mathbf{F}^t \mathbf{F}$.

All existing design approaches are (implicitly) based on a deterministic framework, since the excitation trajectory design does not consider uncertainties on the measurements or the parameter estimates. This section presents a new approach toward the design of robot excitation trajectories which is based on a statistical framework. It differs from the existing methods in two aspects: the parameterization of the trajectory and the optimization criterion.

A. Parameterization of the Robot Excitation Trajectory

The excitation trajectory for each joint is a finite sum of harmonic sine and cosine functions, i.e., a finite Fourier series. The angular position q_i , velocity \dot{q}_i , and acceleration \ddot{q}_i trajectories for joint i of a n -degrees-of-freedom robot are written as

$$\begin{aligned} q_i(t) &= \sum_{l=1}^{N_i} \frac{a_l^i}{\omega_f l} \sin(\omega_f l t) - \frac{b_l^i}{\omega_f l} \cos(\omega_f l t) + q_{i0} \\ \dot{q}_i(t) &= \sum_{l=1}^{N_i} a_l^i \cos(\omega_f l t) + b_l^i \sin(\omega_f l t) \\ \ddot{q}_i(t) &= \sum_{l=1}^{N_i} -a_l^i \omega_f l \sin(\omega_f l t) + b_l^i \omega_f l \cos(\omega_f l t) \end{aligned} \quad (11)$$

with ω_f the fundamental pulsation of the Fourier series. This Fourier series specifies a periodic function with period $T_f = 2\pi/\omega_f$. The fundamental pulsation is common for all joints, in order to preserve the periodicity of the overall robot excitation. Each Fourier series contains $2 \times N_i + 1$ parameters, that constitute the degrees of freedom for the optimization problem: a_l^i , and b_l^i , for $l = 1$ to N_i , which are the amplitudes of the cosine and sine functions, and q_{i0} which is the offset on the position trajectory. The offset determines the robot configuration around which excitation will occur. The parameters for all joints are grouped into vector $\boldsymbol{\delta}$.

This approach guarantees bandlimited periodic trajectories and therefore allows:

- time-domain data averaging, which improves the signal-to-noise ratio of the experimental data. This is extremely

important since motor current (torque) measurements are very noisy.

- estimation of the characteristics of the measurement noise [7]. This information is valuable in case of maximum-likelihood parameter estimation. Section V-A discusses the estimation of the noise variance in detail.
- specification of the bandwidth of the excitation trajectories, such that excitation of the robot flexibility can be either completely avoided or intentionally brought about.
- calculation of joint velocities and accelerations from the measured response in an analytic way. For this purpose, the measured encoder readings are first approximated, in a least squares sense, as a finite sum of sine and cosine functions. This corresponds to taking the discrete Fourier transform of the encoder readings and selecting the main spectral lines. The Fourier transform does not introduce leakage errors because of the periodicity of the excitation. This frequency-domain approach toward the differentiation of time series is simple, efficient, and accurate.

None of the existing robot excitation methods possesses the above mentioned features with the result that

- large data records, which are necessary in order to obtain reliable parameter estimates, cannot be compressed and result in large overdetermined sets of equations which require large numbers of calculations to be solved;
- the calculation of joint velocities and accelerations requires complex numerical differentiation techniques or specially designed IIR filters [17]. This approach is less accurate than the exact frequency-domain approach which is only possible if the excitation is periodic;
- estimation of the noise characteristics requires extra experiments;
- special precautions have to be taken, for example filtering of the excitation trajectory, in order to avoid excitation of the robot flexibility.

B. Optimization of the Parameterized Robot Excitation Trajectory

The covariance matrix of the estimated model parameters is the only correct experiment design criterion if the parameter estimation is approached within a statistical framework [5].

If the joint angle measurements are free of noise, and if the model parameters are estimated according to maximum-likelihood criterion (7), the covariance matrix of the estimated model parameters equals (9). Expression (9) does not depend on the measurements or the estimated parameters. It depends on the exact joint angles, velocities and accelerations which are assumed to correspond to the designed excitation trajectory. As a result, the optimization of the model parameter covariance matrix as a function of the trajectory parameters $\boldsymbol{\delta}$ does not require the knowledge of the exact model parameter vector $\boldsymbol{\theta}$.

The covariance matrix of the parameter estimates can not be calculated if the actuator torque and joint angle measurements are both corrupted by noise [7]. However, the covariance matrix approaches the Cramér–Rao lower bound, i.e., the

inverse of the Fisher information matrix [(6)], asymptotically if the parameters are estimated with an efficient estimator, for example a maximum-likelihood estimator. This suggests taking the Cramér–Rao lower bound on the covariance matrix instead of the covariance matrix itself as the robot excitation design criterion. The Cramér–Rao lower bound or the Fisher information matrix [(6)] depend only on parameter vector ϑ (5), since the exact data, i.e., the exact joint angles, velocities and accelerations and the exact actuator torques, can be calculated from ϑ using (1) and (11). Hence minimization of the Cramér–Rao lower bound in δ requires the knowledge of the exact model parameter vector θ , which however, is not available. Nevertheless, a consistent estimate of the Cramér–Rao lower bound can be calculated from a consistent, i.e., a maximum-likelihood, estimate of θ .

This suggests an iterative procedure in which the Cramér–Rao lower bound is minimized as a function of the trajectory parameters δ for successive maximum-likelihood estimates of model parameter vector θ . The iterative process starts with an initial estimate of θ . It results from initial experimental data obtained from a robot excitation which has been optimized according to the condition number of matrix F . Based on the initial estimate of θ , the Cramér–Rao lower bound is minimized as a function of δ , resulting in a new excitation trajectory. Hence robot excitation and parameter estimation can be repeated until convergence occurs.

The covariance matrix or its Cramér–Rao lower bound cannot be optimized in matrix sense. They have to be replaced by a representative scalar measure. Ljung [5] presents some possible scalar measures. $-\log \det M$, with M the covariance matrix or its Cramér–Rao lower bound, is called the *d-optimality* criterion and is the most appealing of these measures: 1) its minimum is independent of the scaling of the parameters and 2) it has a physically interpretation: the determinant of M is related to the volume of highest probability density region for the parameters [15].

The minimization of the uncertainty on the estimated parameters or its lower bound is a complex nonlinear optimization problem with motion constraints. The motion constraints are limitations on the joint angles, velocities, and accelerations, and on the robot end effector position in the cartesian space in order to avoid collision with the environment and with itself. This last type of constraint involves forward kinematics calculations. All constraints are implemented as continuous functions which are negative if the constraint is satisfied and positive if it is violated.

IV. NUMERICAL EXAMPLE AND SIMULATION OF EXPERIMENT

This section shows, by means of simulations, that:

- 1) the proposed maximum-likelihood parameter estimator is (asymptotically) efficient and unbiased;
- 2) that the excitation trajectory resulting from optimization of the determinant of the covariance matrix yields parameter estimates with smaller variances than robot excitation optimized through minimization of the condition number.

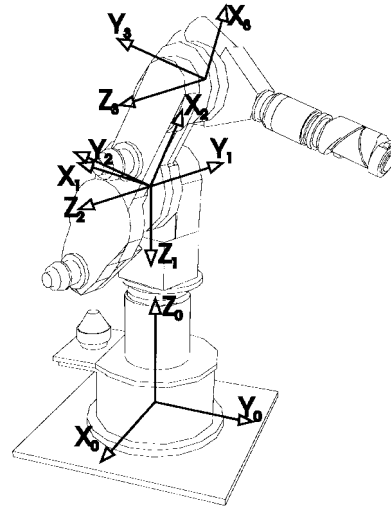

Fig. 1. KUKA 361 IR robot.

The simulation uses a model of a KUKA IR 361 robot. Only the first three axes are considered. Fig. 1 shows the robot, its base coordinate system (X_0, Y_0, Z_0) , and coordinate systems for the first three links: $(X_i, Y_i, Z_i), i = 1, 2, 3$. The inertial parameters of the links are related to their coordinate systems.

- $I_{xx}^i, I_{yy}^i, I_{zz}^i$ are the moments of inertia of link i about the $X_i, Y_i,$ and Z_i axis, respectively, $i = 1, 2, 3$.
- $I_{xy}^i, I_{yz}^i, I_{xz}^i$ are the inertia products of link $i, i = 1, 2, 3$.
- (l_x^i, l_y^i, l_z^i) is the position of the center of mass of link i in $(X_i, Y_i, Z_i), i = 1, 2, 3$.
- $l_z^{i(i+1)}$ is the position of the joint of link $i + 1$ in $(X_i, Y_i, Z_i), i = 0, 1, 2$.
- m_i : is the mass of link $i, i = 1, 2, 3$.

The joint friction model includes viscous and Coulomb friction, represented by constant coefficients b_i and c_i , respectively.

A. The Robot Model

The robot model has been derived according to the modified Newton–Euler formalism [11]. Columns 2 and 3 of Table I present the resulting minimal set of parameters after model reduction and the values that are used for the simulation experiments, respectively. The minimal robot model is given by (1) for which τ is a 3×1 column vector, θ a 21×1 column vector, and Φ a 3×21 matrix. The exact actuator torques are calculated according to (1) using the model parameters presented in Table I and an optimized excitation trajectory. Section IV-B discusses the trajectory optimization. Adding independent zero-mean Gaussian noise to the exact actuator torques simulates torque measurement noise. The variance of the noise is $25 \text{ N}^2\text{m}^2$, $26 \text{ N}^2\text{m}^2$, and $10 \text{ N}^2\text{m}^2$ for the actuator torques of joint 1, 2, and 3, respectively. These values correspond to experimentally obtained noise variance values. The joint angles are assumed to be free of noise. Consequently, the MLE of the model parameters is given by (7).

TABLE I
DATA FOR THE SIMULATION EXPERIMENTS

1	2	3
i	physical meaning of parameter	θ_i
1	$I_{zz}^1 + I_{yy}^2 + (l_z^{1(2)})^2 m_3 + I_{yy}^3$	[kgm ²] 45.38
2	$m_2 l_x^{22} + l_z^{1(2)} m_3$	[kgm] -0.31
3	$m_2 l_y^{22}$	[kgm] -2.22
4	$I_{xx}^2 - I_{yy}^2 - (l_z^{1(2)})^2 m_3$	[kgm ²] -28.69
5	I_{xy}^2	[kgm ²] 0.3
6	$I_{xz}^2 + -l_z^{1(2)} m_3 l_z^{23}$	[kgm ²] -0.2
7	I_{yz}^2	[kgm ²] 3.36
8	$I_{zz}^2 + (l_z^{1(2)})^2 m_3$	[kgm ²] 41.74
9	$m_3 l_x^{33}$	[kgm] 0.07
10	$m_3 l_y^{33}$	[kgm] 2.6
11	$I_{xx}^3 - I_{yy}^3$	[kgm ²] 8.21
12	I_{xy}^3	[kgm ²] 0.07
13	I_{xz}^3	[kgm ²] -0.21
14	I_{yz}^3	[kgm ²] 0.69
15	I_{zz}^3	[kgm ²] 7.63
16	b_1	[Nm s] 17.76
17	b_2	[Nm s] 33.48
18	b_3	[Nm s] 23.11
19	c_1	[Nm] 35.12
20	c_2	[Nm] 6.35
21	c_3	[Nm] 14.51

B. Trajectory Optimization

The robot excitation trajectory is optimized according to two criteria.

- c1) The condition number of the normalized $\Sigma^{-0.5} \mathbf{F}$ matrix [(7)]. This criterion corresponds to the criterion used in [2], [3], [4], except that matrix \mathbf{F} is scaled with the reciprocal values of the standard deviation of the noise on the actuator torques, and that the resulting matrix is normalized. The scaling with the reciprocal values of the standard deviation can be justified by the fact that maximum-likelihood estimation, which corresponds to weighted linear least squares in this case, is used instead of standard linear least squares estimation.
- c2) $-\log \det(\mathbf{F}^t \Sigma^{-1} \mathbf{F})$. $\mathbf{F}^t \Sigma^{-1} \mathbf{F}$ is the information matrix related to the maximum-likelihood estimation of the parameters. It is equal to the inverse of the covariance matrix of the parameter estimates [(9)].

Both optimization criteria are comparable with respect to complexity of implementation and efficiency.

The motion constraints correspond to those of the KUKA IR 361 in our laboratory environment.

- Joint angle limits (rad): $-1.6 < q_1 < 1.6$, $-1.2 < q_2 < 1.2$ and $-1.2 < q_3 < 1.2$.
- Joint velocity limits (rad/s): $-1.45 < \dot{q}_i < 1.45$.
- Joint acceleration limits (rad/s²): $-3 < \ddot{q}_i < 3$.
- Limits on the height of the end effector (mm): $800 < z_{ee}$.
- The robot touches its base if $r_{ee} < 700$ mm and $z_{ee} < 1800$ mm. r_{ee} is the distance of the end effector from the first robot axis. z_{ee} is the height of the end effector above the ground. r_{ee} and z_{ee} are obtained from forward kinematics calculations.

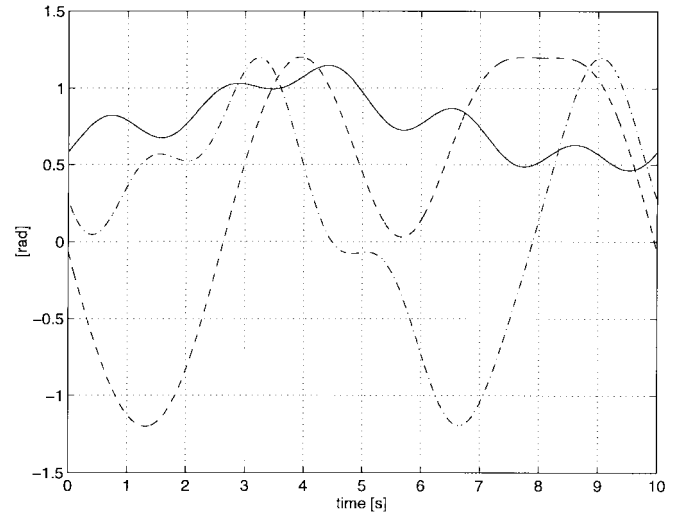

Fig. 2. Robot excitation trajectory optimized according to the criterion based on the condition number (criterion 1) (solid line: axis 1, dashed line: axis 2, dash-dotted line: axis 3).

The excitation trajectories are five-term Fourier series, yielding 11 parameters for each joint. The fundamental frequency of the trajectories is 0.1 Hz. The sampling rate for the simulation is 150 Hz. The length of the data sequence is 1500 data samples, i.e., one period of the trajectory.

The constrained optimizations are performed using the “CONSTR” function of the Optimization Toolbox of Matlab. This function uses a sequential quadratic programming method. Reference [18] describes the Matlab implementation of the constrained optimization in detail.

Fig. 2 shows the optimized excitation trajectories according to the criterion based on the condition number. The iteration process was stopped after 10 000 iterations, where it reached a condition number equal to 4.15. The determinant of the covariance matrix corresponding to this trajectory is equal to $1.76 \cdot 10^{-43}$. Fig. 3 shows the optimized excitation trajectories according to the criterion based on the determinant of the covariance matrix. The iteration process was also stopped after 10 000 iterations, where it reached a determinant equal to $2.36 \cdot 10^{-49}$. The condition number of the normalized \mathbf{F} matrix corresponding to this trajectory is equal to 5.94. These values show that both criteria result in small condition numbers. The values for the determinant are different: the minimization of the determinant criterion produces an excitation trajectory which results in parameter estimates with smaller uncertainty bounds.

Columns 3 and 4 of Table II shows the square root of the diagonal elements of the covariance matrix [(9)] corresponding to both trajectories (σ_{c1} and σ_{c2} for criterion c1 and c2, respectively). These elements are the standard deviations of the maximum-likelihood model parameter estimates. These columns show that all standard deviations corresponding to the second criterion are smaller than the standard deviations corresponding to the first criterion, except for parameters 2, 9, 16, 17, 20, and 21. The overall uncertainty on the parameter estimates is measured by the determinant of the

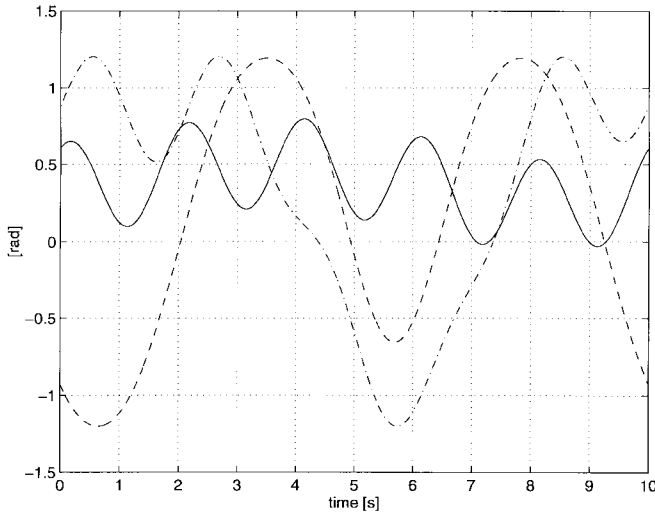

Fig. 3. Robot excitation trajectory optimized according to the criterion based on the determinant of the covariance matrix (criterion 2) (solid line: axis 1, dashed line: axis 2, dash-dotted line: axis 3).

covariance matrix, which is a measure for the volume of highest probability density region for the parameters [15]. The determinant of the covariance matrices ($1.76 \cdot 10^{-43}$ and $2.36 \cdot 10^{-49}$) show that the overall uncertainty on the parameter estimates is smaller for trajectory two than for trajectory one.

In order to check the (asymptotic) unbiasedness and efficiency of the maximum-likelihood estimator, the parameter estimation is simulated $N_s = 200$ times for the trajectory shown in Fig. 3 and different sequences of zero-mean Gaussian actuator torque noise. This enables the calculation of the mean value $\bar{\theta}$ and the standard deviation σ_e of the parameter estimates $\hat{\theta}_j$ (columns 2 and 5 of Table II, respectively):

$$\bar{\theta}_i = \frac{1}{N_s} \sum_{j=1}^{N_s} \hat{\theta}_{ij}$$

$$\sigma_{e_i}^2 = \frac{1}{N_s - 1} \sum_{j=1}^{N_s} (\hat{\theta}_{ij} - \bar{\theta}_i)^2 \quad \text{for } i = 1 \text{ to } 21.$$

Subscript i denotes the i th element of the parameter vector. Subscript j denotes the j th estimate of the parameter vector.

The parameter estimates $\hat{\theta}_{ij}$ are samples of a normal distribution with mean θ_i and standard deviation $\sigma_{c2,i}^2$ (see Section II). $\sigma_{c2,i}^2$ is the i th diagonal element of the covariance matrix of the parameter estimates [9]. Their mean value $\bar{\theta}_i$ has a normal distribution, with mean θ_i and standard deviation $\sigma_{c2,i}^2/N_s$. The 68% confidence interval for the mean value is

$$\left[\theta_i - \frac{\sigma_{c2,i}}{\sqrt{N_s}} < \bar{\theta}_i < \theta_i + \frac{\sigma_{c2,i}}{\sqrt{N_s}} \right].$$

Column 6 of Table II shows the values $\sigma_{c2,i}/\sqrt{N_s}$. Comparison of columns 3 (Table I), 2 and 6 (Table II) shows that 16 of the 21 mean parameter values $\bar{\theta}_i$, i.e., $\pm 76\%$, lie within their confidence interval. This shows that the MLE of θ is unbiased for a data record of 1500 data samples. Shorter data records, for example data records of 500 data samples, result in biased estimates.

TABLE II
RESULTS OF THE SIMULATION EXPERIMENTS

1	2	3	4	5	6
i	θ_i	σ_{c1i}	σ_{c2i}	σ_{ei}	$\frac{\sigma_{c2i}}{\sqrt{N_s}}$
1	45.3769	0.2024	0.1503	0.1461	0.0106
2	-0.3110	0.0283	0.0303	0.0271	0.0021
3	-2.2184	0.0251	0.0199	0.0180	0.0014
4	-28.6897	0.3678	0.1674	0.1641	0.0118
5	0.3042	0.1828	0.0878	0.0870	0.0062
6	-0.1951	0.1592	0.0866	0.0889	0.0061
7	3.3661	0.1459	0.0920	0.0924	0.0065
8	41.7510	0.1953	0.1449	0.1343	0.0102
9	0.0698	0.0115	0.0140	0.0134	0.0010
10	2.6005	0.0178	0.0152	0.0154	0.0011
11	8.2065	0.2881	0.1184	0.1147	0.0084
12	0.0699	0.1563	0.0616	0.0631	0.0044
13	-0.2094	0.0791	0.0343	0.0364	0.0024
14	0.6944	0.0757	0.0436	0.0420	0.0031
15	7.6281	0.0679	0.0463	0.0472	0.0033
16	17.7620	0.4178	0.4366	0.4234	0.0309
17	33.4743	0.2111	0.2872	0.2781	0.0203
18	23.0801	0.3497	0.3008	0.3161	0.0213
19	35.1461	0.2345	0.2248	0.2255	0.0159
20	6.3407	0.1731	0.2185	0.2310	0.0154
21	14.5178	0.1429	0.1970	0.2031	0.0139

The ratios σ_{ei}/σ_i have a χ^2 distribution with $N_s - 1$ degrees of freedom. The 90% confidence interval equals

$$\left[\frac{\sqrt{2N_s - 1} - 1.645}{\sqrt{2}\sqrt{N_s - 1}} < \frac{\sigma_{ei}}{\sigma_{c2i}} < \frac{\sqrt{2N_s - 1} + 1.645}{\sqrt{2}\sqrt{N_s - 1}} \right]$$

$$\left[0.923 < \frac{\sigma_{ei}}{\sigma_{c2i}} < 1.089 \right].$$

Column 5 of Table II shows the variance estimates σ_{ei} . Comparison of columns 4 and 5 shows that 19 of the 21 ratios, i.e., $\pm 90\%$, lie within the confidence interval. This shows that the MLE of θ is efficient for a data record of 1500 data samples. Shorter data records, for example data records of 500 data samples, result in parameter estimates for which the covariance matrix is significantly larger than the Cramér-Rao bound.

V. EXPERIMENTAL VERIFICATION

This section illustrates the presented robot excitation design method and the maximum-likelihood estimation method by means of identification experiments on the **first three links** of a KUKA IR 361 industrial robot (see Fig. 1). The experimental identification is based on the minimal model set described in Section IV. The parameter set is extended with parameters that measure the offset on the torque measurements and parameters that model the spring which compensates the gravitation for the second link [19]. Section V-A describes the experiments and the data processing. Section V-B describes the estimation of the parameters and Section V-C describes the validation of the model.

A. Description of the Experiments and Data Processing

The first three links of the KUKA robot have been identified for two different excitation trajectories: (1) a trajectory

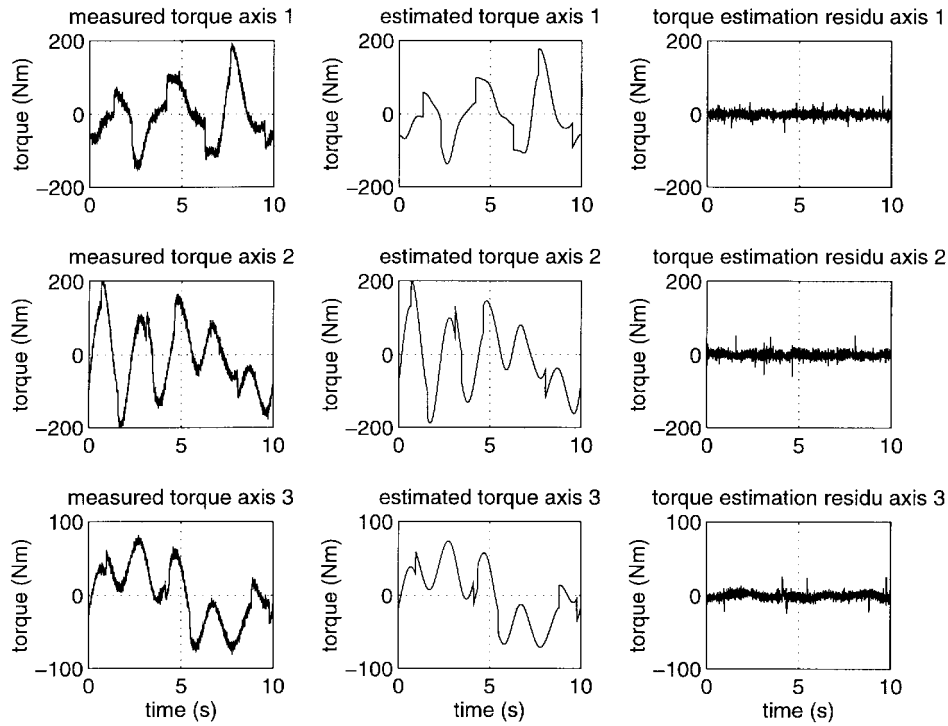

Fig. 4. Measured torque, estimated torque, and estimation residue.

which is optimized according to the condition number of the normalized $\Sigma^{-0.5}\mathbf{F}$ matrix [(7)], and (2) a trajectory which is optimized according to $-\log \det \mathbf{F}^t \Sigma^{-1} \mathbf{F}$ [(9)]. Criterion two is based on the assumption that the measured joint angles are free of noise and that (7) is the MLE. The experimental results will show that the noise on the joint angle measurements is not zero but small, and that its influence of the MLE is negligible. Consequently, the assumption is valid.

Trajectory 1 yields a condition number equal to 47.3 and a determinant equal to $5.26 \cdot 10^{-46}$. Trajectory 2 yields a condition number equal to 111.7 and a determinant equal to $1.85 \cdot 10^{-56}$. These condition numbers are significantly higher than the condition numbers obtained in Section IV due to the parameters modeling the gravity compensation spring.

The models obtained using trajectory 1 and 2 are referred to as models 1 and 2, respectively.

The motion constraints, the sampling frequency, and the number of parameters and the fundamental frequency of the excitation trajectory are the same as for the simulation experiments (see Section IV-B). Data are collected after the transient response of the robot has died out. The joint angle is measured by means of an encoder mounted on the motor shaft, and the actuator torque is measured indirectly by means of the motor current. Analog eighth-order low-pass Butterworth filters¹ with a bandwidth of 40 Hz protect the sampling of the motor current signal from aliasing errors. This filtering introduces amplitude and phase distortions, which are corrected by *prewhitening* the sampled motor current sequences [5]. Prewhitening also removes the coloring and correlation of the measurement noise

introduced by the analog anti-aliasing filters. The formulated maximum-likelihood parameter estimation method assumes uncorrelated measurement noise. The prewhitening filters are the inverse of the digital equivalents of the analog filters. The digital equivalents are obtained by means of maximum-likelihood frequency-domain identification based on measured frequency response functions of the analog filters [7]. The inversion of the digital equivalents is based on the *extended bandwidth zero phase error tracking method* [18], [20].

Following the data prewhitening, the data sequences are averaged over 16 periods in order to improve the signal-to-noise ratio of the measurements. Fig. 4 shows the averaged motor torque measurements. The variance of the noise on the averaged joint angle and actuator torque measurements is estimated by calculating the sample variance and dividing it by 16

$$\hat{\sigma}_{q_i}^2 = \frac{1}{16} \frac{1}{(16N-1)} \sum_{k=1}^N \sum_{j=1}^{16} (q_{ij}(k) - \bar{q}_i(k))^2$$

$$\hat{\sigma}_{\tau_i}^2 = \frac{1}{16} \frac{1}{(16N-1)} \sum_{k=1}^N \sum_{j=1}^{16} (\tau_{ij}(k) - \bar{\tau}_i(k))^2$$

N is equal to number of samples per period, i.e., 1500. Subscript j indicates the excitation period ($j = 1, 2, \dots, 16$). $\bar{q}_i(k)$ and $\bar{\tau}_i(k)$ represent the averaged encoder and motor torque measurements. Remark that the estimation of the variance according to the above-mentioned equations and the improvement of the signal to noise ratio through data averaging are only possible because of the periodicity of the excitation. The estimated variances are $1.1223 \cdot 10^{-10} \text{rad}^2$, $8.2822 \cdot 10^{-11} \text{rad}^2$, $2.9061 \cdot 10^{-10} \text{rad}^2$ for the position of,

¹The used filters are manufactured by: GEPA gmbH, 80707 München, Germany

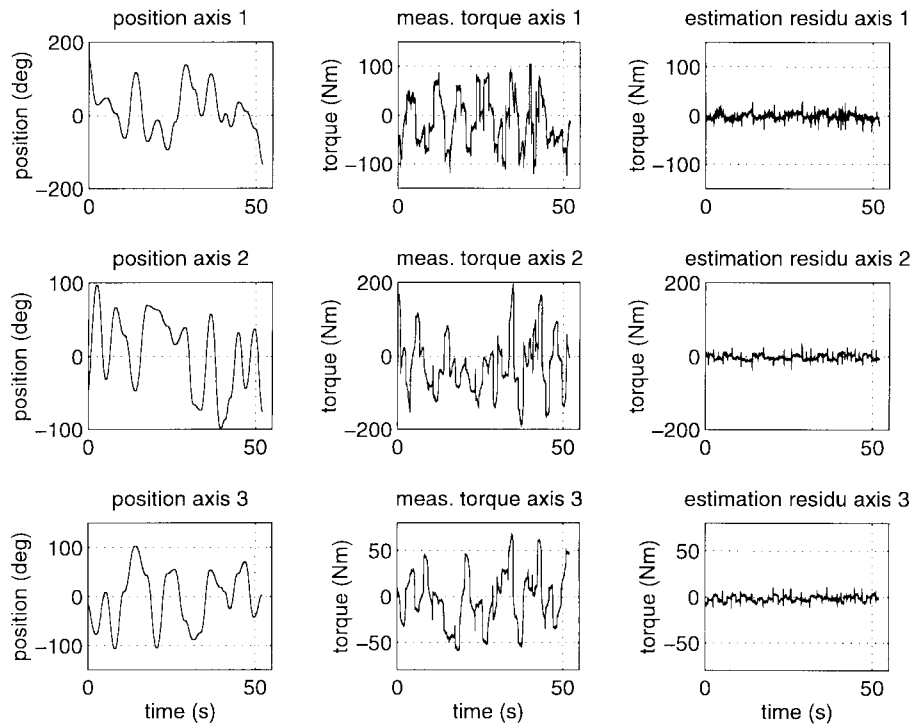

Fig. 5. Position, measured torque and estimation residue for the validation trajectory.

respectively, axes 1, 2, and 3 and $25.1086 \text{ N}^2\text{m}^2$, $25.9428 \text{ N}^2\text{m}^2$, and $9.8947 \text{ N}^2\text{m}^2$ for the torque of, respectively, axes 1, 2, and 3.

B. Maximum-Likelihood Parameter Estimation

The optimization of criterion (4) is an iterative procedure which starts with linear least squares estimates of the trajectory and model parameters. The weighted least squares estimate of the trajectory parameters is based on the averaged joint angle measurements and (11). The linear least squares estimate of the model parameters is based on the averaged actuator torque measurements and (10) in which \mathbf{F} is calculated using the estimated trajectory parameters instead of the averaged joint angle measurements. Comparison of the maximum-likelihood estimate and the initial weighted least squares estimate of the model and trajectory parameters showed that there is no difference between both and therefore the influence of the joint angle noise on the MLE is negligible, which could be expected from its small mean variance values.

Fig. 4 shows the measured and estimated actuator torques, and the estimation residue for model 2. The estimation residues for model 1 are comparable. However, we must bear in mind that this comparison is not completely justified since the two trajectories are not the same. The peaks in the estimation residu occur at low joint angular velocity, which indicates that the assumed friction model, which includes viscous and Coulomb friction, is too simple. It can be expected that including more advanced friction and gear models, as described, e.g., in [21] and [22], results in smaller estimation residus. Due to these modeling errors, the mean values of the squared estimation residue ($81.1050 \text{ N}^2\text{m}^2$, $88.8175 \text{ N}^2\text{m}^2$,

and $23.1119 \text{ N}^2\text{m}^2$ for, respectively, axes 1, 2 and 3) are larger than the noise variances of the measured torques. Despite modeling errors (stiction, backlash and flexibility in the transmissions, kinematic errors) the estimated models are accurate but biased.

As a result of this bias, the diagonal elements of matrix $(\mathbf{F}^t \Sigma^{-1} \mathbf{F})^{-1}$ [(9)], which is the covariance matrix of the parameter estimates in the assumption that the estimation is efficient and unbiased, are no longer valid estimates of the parameter uncertainty. As a result the identified parameters do not lie within the 3σ uncertainty ranges.

C. Model Validation

The accuracy of the obtained parameter estimates can be verified for a different validation trajectory by comparing the measured torques and an estimate of these torques based on the model and the measured position data.

The validation trajectory goes through 20 points randomly chosen in the workspace of the robot. The robot moves with maximum acceleration and deceleration between these points, and comes to full stop in each point. The velocities and accelerations are calculated by means of specially designed filters [17].

Fig. 5 shows the position, the measured torque, and the estimation residu for model 2. The torques are filtered with a low pass filter with cutoff frequency of 10 Hz. This reduces the noise on

- the measured torques, which is high due to the inverse filtering to compensate the analog filter (cf. Section V-A) and because data averaging is not possible here;

- the estimated torque due to noise on the calculated acceleration and velocity data

The mean squared torque estimation residu for the validation trajectory is 45.0424 N²m², 53.5891 N²m², and 12.0303 N²m² for the axes 1, 2, and 3. Model 1 yields mean squared torque estimation residus which are approximately 20% larger than the mentioned values, indicating that model 2 is more accurate than model 1 with respect to its ability to predict the motor torques based on joint angular position measurements. The biasedness of the parameter estimates prevents formulating statements with respect to the uncertainty on the parameter of both models.

VI. CONCLUSION

The presented robot excitation design method generates trajectories which aim at estimating the robot model parameters with minimal uncertainty. In addition, the trajectories are periodic and have a band-limited frequency contents. These attractive properties simplify the analysis and conditioning of the measurements, for example the estimation and improvement of the signal-to-noise ratio.

The formulated maximum-likelihood estimation method takes into account actuator torque and joint angle measurement noise, i.e., combines the estimation of exact joint angles, angular velocities and accelerations, with the estimation of the robot parameters. Simulations show that the maximum-likelihood estimation method is asymptotically unbiased and efficient.

Experiments on an industrial robot show the practicability of the presented trajectory design and parameter estimation methods: the obtained robot model is more accurate than the model obtained using excitation trajectories designed according to the more traditional condition number criterion.

ACKNOWLEDGMENT

This paper presents research results of the Belgian Program on Interuniversity Poles of attraction initiated by the Belgian State, Prime Minister's Office, Science Policy Programming. The scientific responsibility is assumed by its authors.

REFERENCES

- [1] G. H. Golub and C. F. Van Loan, *Matrix Computations*. Baltimore, MD: The Johns Hopkins Univ. Press, 1989.
- [2] M. Gautier, C. Janin, and C. Presse, "Dynamic identification of robots using least squares and extended kalman filtering methods," in *Proc. Second Europ. Contr. Conf.*, Groningen, The Netherlands, 1993, pp. 2291–2296.
- [3] M. Gautier and W. Khalil, "Exciting trajectories for the identification of base inertial parameters of robots," *Int. J. Robot. Res.*, vol. 11, no. 4, pp. 362–375, 1992.
- [4] K. Otani and T. Kakizaki, "Motion planning and modeling for accurately identifying dynamic parameters of an industrial robotic manipulator," in *24th ISIR*, Tokyo, Japan, 1993, pp. 743–748.
- [5] L. Ljung, *System Identification: Theory for the User*. Englewood Cliffs, NJ: Prentice-Hall, 1987.
- [6] S. Van Huffel and J. Vandewalle, "Analysis and properties of the generalized total least squares problem $A \approx B$ when some or all columns in A are subject to error," *SIAM J. Matrix Anal. Appl.*, vol. 10, no. 3, pp. 294–315, 1989.
- [7] J. Schoukens and R. Pintelon, *Identification of Linear Systems: A Practical Guideline to Accurate Modeling*. Oxford, England: Pergamon, 1991.

- [8] J. Swevers, B. De Moor, and H. Van Brussel, "Stepped sine system identification, errors-in-variables and the quotient singular value decomposition," *Mech. Syst. Signal Processing*, vol. 6, no. 2, pp. 121–134, 1992.
- [9] F. Xi, "Effect of nongeometric errors on manipulator inertial calibration," in *Proc. IEEE Int. Conf. Robot. Automat.*, May 21–26, 1995, pp. 1808–1813.
- [10] P. Fisette, B. Raucent, and J.-C. Samin, "Minimal dynamic characterization of tree-like multibody systems," in *Computer-Aided Analysis of Rigid and Flexible Mechan. Syst., NATO-Advanced Study Inst.*, Troia, Portugal, 1993, vol. II, pp. 111–129.
- [11] C. Atkeson, C. An, and J. Hollerbach, "Estimation of inertial parameters of manipulator loads and links," *Int. J. Robot. Res.*, vol. 5, no. 3, pp. 101–119, 1986.
- [12] J. M. Renders, E. Rossignol, M. Becquet, and R. Hanus, "Kinematic calibration and geometrical parameter identification for robots," *IEEE Trans. Robot. Automat.*, vol. 7, pp. 721–732, 1991.
- [13] C. W. Wampler, J. M. Hollerbach, and T. Arai, "An implicit loop method for kinematic calibration and its application to closed-chain mechanisms," *IEEE Trans. Robot. Automat.*, vol. 11, pp. 710–724, 1995.
- [14] G. Zak, B. Benhabib, R. G. Fenton, and I. Saban, "Application of weighted least squares parameter estimation method to the robot calibration," *Trans. ASME, J. Mech. Design*, vol. 116, pp. 890–893, Sept. 1994.
- [15] G.C. Goodwin and R.L. Payne, *Dynamic System Identification: Experiment Design and Data Analysis*. New York: Academic, 1977.
- [16] B. Armstrong, "On finding exciting trajectories for identification experiments involving systems with nonlinear dynamics," *Int. J. Robot. Res.*, vol. 8, no. 6, pp. 28–48, 1989.
- [17] R. Pintelon and J. Schoukens, "Real-time integration and differentiation of analog signals by means of digital filtering," *IEEE Trans. Instrum. Meas.*, vol. 39, pp. 923–927, 1990.
- [18] J. Swevers, C. Ganseman, J. De Schutter, and H. Van Brussel, "Additional remarks related to the paper: Optimal robot excitation and identification," Tech. Rep. 95R65, K.U. Leuven, Div. P.M.A., B 3001 Heverlee, Belgium, 1995.
- [19] J. Swevers, C. Ganseman, J. De Schutter, and H. Van Brussel, "Experimental robot identification using optimized periodic trajectories," *Mech. Syst. Signal Processing*, vol. 10, no. 5, pp. 561–577, 1996.
- [20] D. Torfs, J. De Schutter, and J. Swevers, "Extended bandwidth zero phase error tracking control of nonminimal phase systems," *Trans. ASME, J. Dynam. Syst., Meas., Contr.*, vol. 114, no. 3, pp. 347–351, 555, 1992.
- [21] B. Armstrong-Hélouvy, *Control of Machines with Friction*. Boston, MA: Kluwer Academic, 1991.
- [22] K. Schroer, "Theory of kinematic modeling and numerical procedures for robot calibration," in *Robot Calibration*, R. Bernhardt and S. L. Albright, Eds. London, England: Chapman and Hall, 1993, ch. 9, pp. 157–195.



Jan Swevers was born in Leuven, Belgium, in 1963. He received the B.E. degree in electrical engineering, in 1986, and the Ph.D. degree in mechanical engineering, in 1992, both from the Katholieke Universiteit (K.U.) Leuven, Heverlee, Belgium.

Since 1992, he has been working as a Senior Research Assistant of the Fund for Scientific Research, Flanders, at the K.U. Leuven, Department of Mechanical Engineering, Division P.M.A. (Production, Machine Design and Automation). He became Associate Professor in 1995. His research interests

include various aspects of system identification and control.



Chris Ganseman was born in Zwevegem, Belgium, in 1969. He received the B.E. degree in mechanical engineering, in 1992, from the Katholieke Universiteit (K.U.) Leuven, Heverlee, Belgium.

Since 1993, he has been a Research Engineer with the K.U. Leuven, Department of Mechanical Engineering, Division P.M.A. (Production, Machine Design, and Automation). His research interests include modeling and identification of the dynamics and friction of robot manipulators.



Dilek Bilgin Tükel was born in Adana, Turkey, in 1965. She received the B.S. degree in electrical engineering in 1987, and the M.S. degree in 1990 from Bogazici University, Istanbul. She also received the Ph.D. degree in mechanical engineering in 1997 from the Katholieke Universiteit Leuven, Heverlee, Belgium.

She is currently with Altinay Robotics and Automation Company, Istanbul, Turkey. Her research interests include modeling and control of multirobot systems and path planning.



Joris De Schutter (M'96) received the degree in mechanical engineering from the Katholieke Universiteit (K.U.) Leuven, Heverlee, Belgium, in 1980, the M.S. degree from the Massachusetts Institute of Technology, Cambridge, in 1981, and the Ph.D. degree in mechanical engineering, also from the K.U. Leuven, in 1986.

He then worked as a control systems engineer in industry. In 1986 he became Lecturer with the Department of Mechanical Engineering, Division PMA (Production Engineering, Machine Design and Automation), K.U. Leuven, where he is now full professor since 1995. He teaches courses in kinematics and dynamics of machinery, control, and robotics, and is the coordinator of the study program in mechatronics. He has published papers on sensor based robot control (especially force control), position control of flexible robots and drive systems, and on robot programming.



Hendrik Van Brussel (S'68-M'71-SM'85-F'95) was born in Ieper, Belgium, on October 24, 1944. He received the degree of technical engineer in mechanical engineering from the Hoger Technisch Instituut, Ostend, Belgium, in 1965, and the M.Sc. degree in electrical engineering from Katholieke Universiteit (K.U.) Leuven, Heverlee, Belgium. In 1971, he received the Ph.D. degree in mechanical engineering, also from K.U. Leuven.

From 1971 to 1973, he was establishing a Metal Industries Development Centre in Bandung, Indonesia, where he also was an associate professor with the Institut Teknologi Bandung, Indonesia. He is presently Full Professor in mechatronics and industrial automation and Chairman of the Department of Mechanical Engineering at K.U. Leuven. He was a pioneer in robotics research in Europe and an active promoter of the mechatronics idea as a new paradigm for concurrent machine design. He has published more than 200 papers on different aspects of robotics, mechatronics, and flexible automation. His present research interests are shifting toward holonic manufacturing systems and precision engineering, including microrobotics.

Dr. Van Brussel is a Fellow of the Society of Manufacturing Engineers, and in 1994 he received a honorary doctor degree from the "Politechnica" University in Bucharest, Romania, and from RWTH, Aachen, Germany. He is also a corresponding member of the Royal Academy of Sciences, Literature, and Fine Arts of Belgium and an active member of the International Institution for Production Engineering Research (CIRP).