

M4B.002

ULTRA-LOW POWER METAL-OXIDE GAS SENSOR ON PLASTIC FOIL

J. Courbat^{1}, D. Briand¹, L. Yue², S. Raible² and N.F. de Rooij¹*

¹Ecole Polytechnique Fédérale de Lausanne (EPFL), Institute of Microengineering (IMT), Sensors, Actuators and Microsystems Laboratory (SAMLAB), Neuchâtel, Switzerland
²AppliedSensor GmbH, Reutlingen, Germany

ABSTRACT

We report on the design and fabrication of ultra-low power metal-oxide (MOX) gas sensors on plastic foils envisioning their fabrication at large scale and low cost. A complete sensor solution is presented including its packaging at the foil level and the driving/readout circuitry. The latter allowed the sensor to operate in pulsed temperature mode to reduce the power consumption in the sub-mW range. Gas measurements under CO, CH₄ and NO₂ have proven the proper operation of the sensor. These devices are being developed targeting wireless applications.

KEYWORDS

Low-power, drop-coated, metal-oxide, gas sensor, polyimide, plastic foil, readout circuitry, foil level packaging.

INTRODUCTION

A growing interest has lately been dedicated to the development of low-power sensors, temperature, humidity, shock, for smart RFID tags. One example in the field of chemical sensors is the work we have been performing on the integration of ultra-low power capacitive gas sensors (VOCs, H₂O) on plastic foil [1]. By processing the devices on plastic substrate, one can envision the direct fabrication at low-cost of sensors on the tag using additive processes.

Here, we have focused here our attention to the development of MOX gas sensors on polyimide substrates based on ultra-low power transducers for wireless applications [2]. We have demonstrated the integration of MOX gas sensors on polyimide substrates before [3], but here we go significantly further by addressing several aspects related to the development of a sensor component. To decrease the power consumption, we have realized on plastic foil the smallest drop-coated MOX gas sensors reported so far. Encapsulation of sensors being most of the time a cost issue and the use of foil not being compatible with standard packaging techniques, a new generic packaging solution at the foil level has been developed for gas sensors on plastic foil. The implemented electronic circuitry, relying on low-power electronic components, to measure the sensor's gas response and to drive the heater is also described. Pulsing the temperature has shown to improve sensitivity [4-5] and selectivity [6] while decreasing the power consumption. Thus, it potentially makes the device suitable for wireless applications.

EXPERIMENTAL

Technical Realization of the Sensor

Figure 1 presents a cross-sectional schematic of the fabricated device. A double spiral platinum-based resistor made on a 50 μm -thick polyimide foil (Upilex-50S from UBE Industries, Ltd.) was used as heating element. The latter was electrically insulated from the Pt-based electrodes by a 700 nm thick spin-coated polyimide layer in between. Transducer platforms with diameters ranging from 100 μm down to 10 μm have been fabricated. Bulk micromachining of polyimide has been considered to further reduce the power consumption of the device [2].

We have decided to go for a scaling down of the drop coating approach for our devices since it has been proven to provide high performance gas sensitive metal-oxide films [7], the techniques being a key point in the successful development of the commercially available micromachined MOX sensors. Custom-made glass capillaries with very small apertures were fabricated for the drop coating of very small droplets of Pd-doped SnO₂ and WO₃ gas sensitive layers on the transducers. Droplets as small as 15 μm in diameter and between 6 and 7 μm in height have been successfully deposited on transducers as small as 15 μm in width (Fig. 2). The MOX layer laying on the transducer was then sintered at 450°C in air for 10 min in an oven.

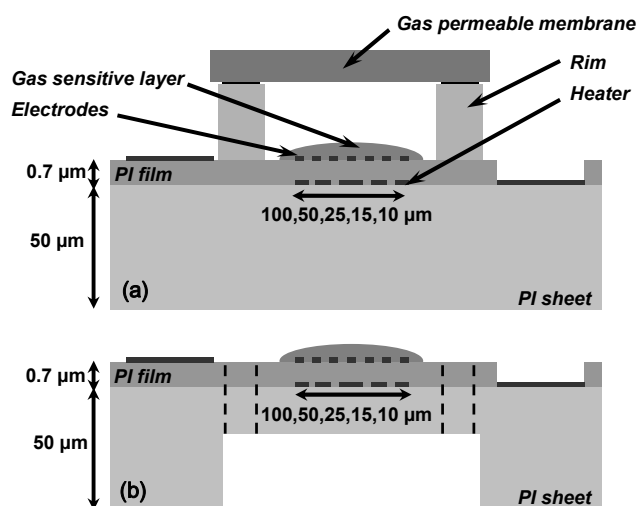

Figure 1: Cross-sectional schematic of a MOX gas sensor on plastic foil (a) bulk, (b) closed and opened membrane (dashed lines).

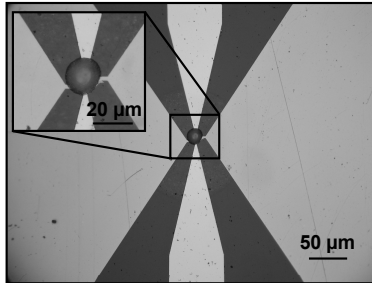

Figure 2. Optical picture of a 15 μm wide transducer with a closed membrane covered with the gas sensitive MOX layer.

The sensing area was finally encapsulated at the foil level using a technique compatible with roll-to-roll processing. It consisted in the lamination of pre-patterned circular rims (50 μm-thick and 500 μm-wide) made of dry epoxy photoresist foil on the polyimide foil with the sensors' structures (Fig. 3a). Due to the high temperature involved during the sintering of the MOX layer, the organic film used to form the rims surrounding the sensors' active areas has to be laminated after the MOX layer coating. A hydrophobic gas permeable membrane was then glued on top of the rim (Fig. 3b) [7]. The device was finally mounted and characterized on PCBs or TO-5 headers, the latter being compatible with the gas measurement system at our disposal. Electrical connections of the sensor were performed by conductive glue dispensing. Other methods are foreseen, such as anisotropic conductive glue dispensing or inkjet printing.

Readout and Driving Circuitry

Since energy is very limited in wireless systems, the ultra-low power MOX sensors on plastic foil have been combined with low-power electronic components (Fig. 4). A readout system based on RC discharge time measurement [8] has been implemented to measure the resistance of the gas sensitive layer, avoiding thus the need of power consuming devices such as operational amplifiers. The principle of operation of the readout circuitry was demonstrated with an Atmel AT90USB1287 microcontroller (not low power, we are considering the MSP430 family from TI for the final demonstrator) available in our laboratory. The measurement cycle began

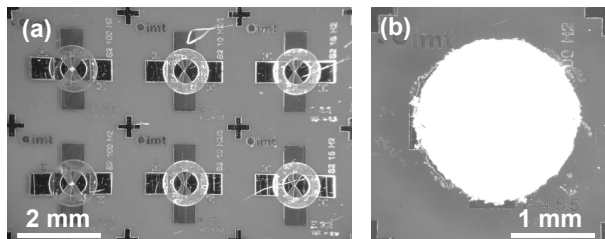

Figure 3. (a) Rim around the transducing area; (b) Sensor covered with the hydrophobic gas permeable membrane.

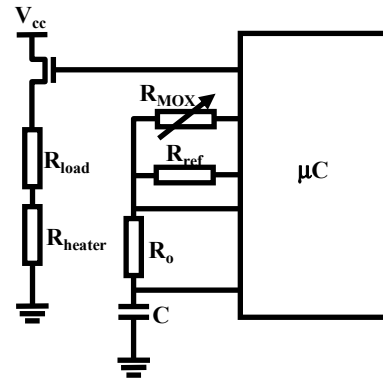

Figure 4. Low power driving and readout circuitry based on RC discharge time for the measurement of the MOX layer.

with the load of the capacitance, C , to the supply voltage of the system, V_{cc} , and then alternatively discharged through the gas sensitive layer resistors, R_{MOX} , the reference resistor, R_{ref} , and R_o , which limited the current sunk by a pin of the microcontroller. A timer measured the time interval from the beginning of the discharge until the decreasing voltage across C reached V_{TH} , a threshold value between logic one and logic zero in the microcontroller.

By combining the three discharge times of $\tau_{MOX} = (R_{MOX} + R_o) \cdot C$, $\tau_{ref} = (R_{ref} + R_o) \cdot C$ and $\tau_o = R_o \cdot C$, the value of the MOX resistor can be computed:

$$R_{MOX} = R_{ref} \cdot \frac{\tau_{MOX} - \tau_o}{\tau_{ref} - \tau_o} \quad (1)$$

R_{MOX} was converted into an analog voltage output and monitored with a multimeter.

The microcontroller was also used as driving circuitry to power up the heating element in both continuous and pulsed temperature modes. In the latter case, the cycle period was between 1 and 2 s with duty cycles between 5 and 10%. The MOX resistance was measured after switching off the heater to take the advantage of the unsteady state of the oxygen species adsorbed in the MOX layer to improve sensitivity to specific pollutant gases such as CO [5]. The temperature of the sensor was adjusted by tuning R_{load} to reach the desired current flow and voltage drop across the micro-heating element.

RESULTS AND DISCUSSION

Power Consumption

For a 15 μm-wide hotplate on a closed PI membrane, operating temperatures from 200 to 300°C, were reached at very low power by increasing it from 3.9 to 6.0 mW (Fig. 5). Due to the very low thermal conductivity of the plastic foil used as substrate, an interesting power consumption of 10 mW at 300°C was reached with a

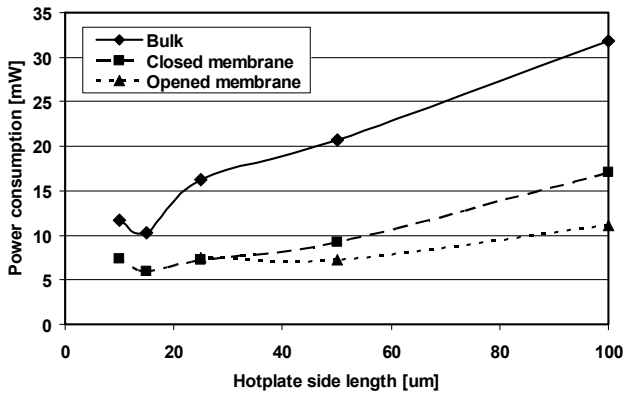

Figure 5. Power consumption of MOX gas sensors at 300°C as a function of the size of the transducers.

15 μm-wide bulk device, simplifying thus the fabrication process by avoiding bulk micromachining and making them more suitable for low-cost applications and attractive compared to silicon-based devices. An increase in power consumption was observed for the smallest devices due to major heat losses through the electrical connection to the heater [2].

Gas Sensing Performances of the Sensors

Figure 6 shows standard gas measurements with a 25 μm-wide sensor with a closed membrane at a constant power of 7.2 mW/300°C. The carrier gas was synthetic air with 50% RH and its flow 200 ml/min. A comparison between a commercially available and a PI-based MOX gas sensors when exposed to CO are shown in Fig. 7, exhibiting the very good performances of the PI devices at lower power. One has to keep in mind that depending on the nature of the MOX layer and the analytes to be detected, lower operating temperatures and thus power consumption are possible.

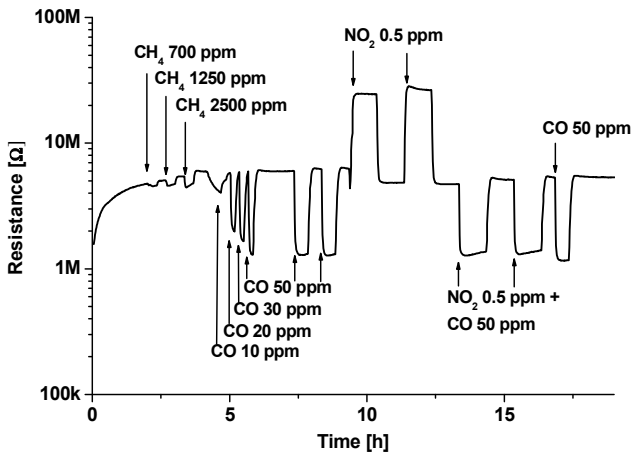

Figure 6. Gas measurements obtained with a 25 μm-wide MOX gas sensor with a closed membrane on polyimide foil at 300°C/13.7 mW in synthetic air with 50% RH, 200 ml/min.

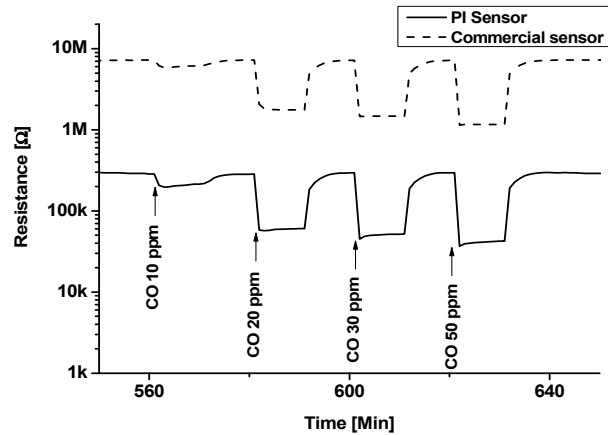

Figure 7. Comparison between commercial (AppliedSensor GmbH) and 50 μm wide PI MOX gas sensor operating at 300°C.

Moreover, by establishing a pulsed temperature mode of operation, the power consumption can be further reduced, making the device more effective for wireless applications. CO measurements were successfully performed at a power of about 340 μW (300°C) (Fig. 8).

Compared to the micromachined devices on silicon, the response of the PI sensors was a lot less affected by variations in the pulsing cycle, length of the off state and time at which the sampling occurred. These effects are currently under investigation for a better understanding.

Electronic Circuitry Evaluation

The power consumption of the MOX sensor to reach several temperatures of operation is presented in Table 1. It decreased with the size of the sensor and can be further reduced by pulsing the temperature of the heater. We have validated here the use of only passive components instead of power consuming active devices, such as operational amplifiers, for the operation of the device. The circuitry worked well at very low power for the readout of the

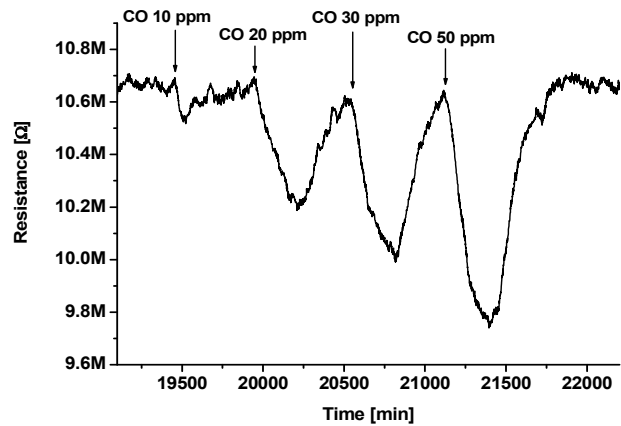

Figure 8. CO measurements in synthetic air with 50% RH, 200 ml/min, obtained with a 25 μm-wide MOX gas sensor on PI foil in temperature pulsed mode by using a cycle of 2 s with duty cycle of 5% (300°C/340 μW).

Table 1. Power consumption for the different designs of MOX sensors on PI operating at constant temperature.

| Sensor size | $P_{\text{sensor}}(200^{\circ}\text{C})$ [mW] | $P_{\text{sensor}}(250^{\circ}\text{C})$ [mW] | $P_{\text{sensor}}(300^{\circ}\text{C})$ [mW] |
|-------------------|---|---|---|
| 100 μm | 20.5 | 28.4 | 34.5 |
| 50 μm | 15.0 | 17.8 | 21.2 |
| 25 μm | 9.1 | 11.3 | 13.7 |
| 15 μm | 7.7 | 9.6 | 11.7 |

sensor. However, R_{load} , used to tune the temperature of the sensor via the heater, increased the power required to drive the heater by 7 to 32 mW due to its intrinsic losses, these values being very close to the power consumption of the sensors themselves. R_{load} being in serie with R_{heater} , the total power consumption relied only on the current required to drive the heater since these two resistors are biased at a constant voltage (3.27 V) by the microcontroller. The use of a very low power microcontroller, such as the MSP430 from TI with a power supply voltage of 1.8 V, combined with a more resistive heater, would allow benefiting more of the ultra-low power consumption of the sensors in a complete system.

Gas measurements performed with the PI-based sensors using the RC discharge time based readout are presented in Fig. 9. The system exhibited a very good response to concentrations of CO as low as 10 ppm in synthetic air with 50% RH. The proper operation of the system has been demonstrated for both continuous and pulsed temperature mode (200°C/1.5 mW, cycle of 1s, duty cycle of 10%).

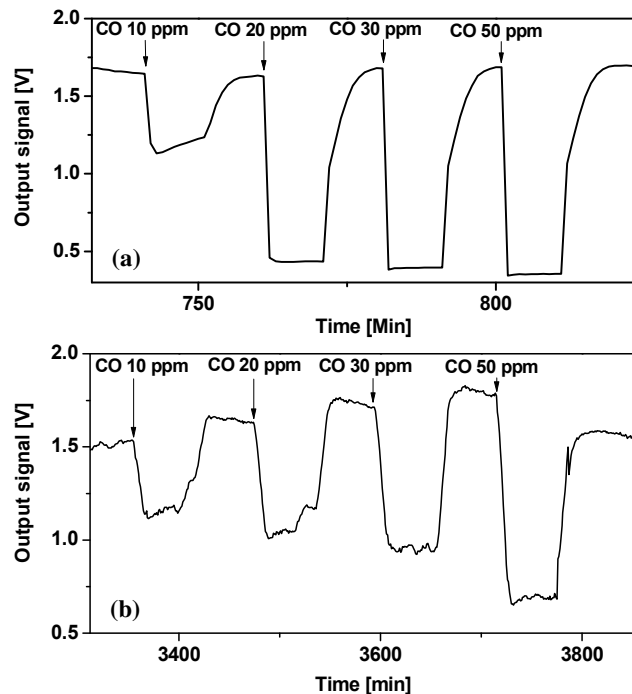

Figure 9. Gas measurement performed with 50 μm wide PI sensor in (a) constant (200°C/15 mW) and (b) pulsed temperature mode (200°C/1.5 mW, cycle of 1s, duty cycle of 10%).

CONCLUSION

Sub-mW MOX gas sensors and their complete integration on plastic foil targeting wireless applications have been demonstrated. Gas measurements of CO, CH₄ and NO₂ in both continuous and pulsed temperature mode have proven the proper operation of the sensors with power consumptions as low as 340 μW for the given testing scenario. Lower power might be reached by further reducing the duty cycle of the heating element.

The adequate choice of the supply voltage for the whole system, i.e. the sensor and its electronics has been highlighted to further decrease the total power consumption. Despite the use of ultra-low power sensors, the reduction of the power consumption of the read-out and driving circuitries is of prime importance for the development of low power sensor systems to avoid major losses in passive electronic components.

ACKNOWLEDGMENTS

We thank GOSPEL, the European Network of Excellence on Artificial Olfaction and Advanced Sensing Technologies for its partial financial support.

REFERENCES

- [1] A. Oprea et al., "Integrated Temperature, Humidity and Gas Sensors on Flexible Substrates for Low-Power Applications", in Proceedings of the IEEE Sensors Conference 2007, Atlanta, October 28-31, 2007, pp. 158-161.
- [2] J. Courbat et al., "Thermal Simulation and Characterization for the Design of Ultra-Low Power Micro-Hotplates on Flexible Substrate", in Proceedings of the IEEE Sensors Conference 2008, Lecce, October 26-29, 2008, pp. 74-77.
- [3] D. Briand et al., "Integration of MOX Gas Sensors on Polyimide Hotplates", Sensors and Actuators A, vol. 130, pp.430-435, 2007.
- [4] M. Schweizer-Berberich et al., "Strategies to avoid VOC cross-sensitivity of SnO₂-based CO sensors", Sensors and Actuators B, vol. 58, pp. 318-324, 1999.
- [5] A. Heilig et al., "Gas Identification by Modulating Temperatures of SnO₂-based thick film sensors", Sensors and Actuators B, vol. 43, pp. 45-51, 1997.
- [6] R.E. Cavicchi et al., "Fast temperature programmed sensing for micro-hotplate gas sensors", IEEE Electron Device Letters, vol. 16, pp. 286-288, 1995.
- [7] D. Briand et al., "Highly Integrated Wafer Level Packaged MOX Gas Sensors", in Proceedings of the Transducers'07 Conference, Lyon, June 10-14, 2007, pp. 2401-2404.
- [8] F. Reverter et al., "Accuracy and Resolution of Direct Resistive Sensor-to-Microcontroller Interfaces", Sensors and Actuators A, vol. 121, pp. 78-87, 2005.

CONTACT

* J. Courbat, tel: +41 (0)32 7205576; jerome.courbat@epfl.ch