

# E-Water Level: Educational Kit For Testing Student Knowledge on Transient Response using Water Level Control

Ezzatul Farhain Azmi, Muhammad Firdaus Ishak, Adam Samsudin,  
Amar Faiz Zainal Abidin, Kamaru Adzha Kadiran

**Abstract:** Control Principle course is a part of syllabus in the diploma or degree in Electrical Engineering programme where students are exposed to topics such as time response analysis. One of the topics in this course is Transient Response analysis where it requires students to calculate the characteristic of the response based on set of formula. One of the difficulty encounters in delivering this topic is students having difficulty to relate the theory with the application as most theoretical part of this topic does not explain on how the transient response graph is obtained in the first place. In order to address this problem, this paper proposed E-Water Level educational kit that can be used by student in order to understand independently the transient response analysis by applying theory on the water level control application where the student knowledge on Transient Response parameters are tested, namely the delay time, rise time, damping ratio and setting time. The system consists of Arduino Microcontroller, water tank, water pump, relay, ultrasonic sensor and electronic display. The novelty of this educational kit is that the educational kit is adaptive in bridging the gap between theory and application in which the data is generated by real application of water level and the answers for the questions are automatically generated based on the data obtained. Thus, each student will experience different set of question.

**Keywords :** Control System, Educational Kit, Quiz Board, Transient Response.

## I. INTRODUCTION

The teaching of control engineering has many pedagogical methodologies over the years with the inclusion of educational platforms in order to motivate, to clarify the concepts, to decrease the abstraction level of the control theory and also to prepare the students for industrial world [1]. D. C. Jeronimo et. al (2014) has discussed the potential of applying a final practical laboratory task into the Feedback systems course as a new approach to learn and teach for

**Revised Manuscript Received on October 05, 2019.**

**Ezzatul Farhain Azmi**, Faculty of Mechanical & Manufacturing Engineering Technology, Universiti Teknikal Malaysia Melaka, Melaka, MALAYSIA. Email: ez.farhain@utem.edu.my

**Muhammad Firdaus Ishak**, Faculty of Electrical Engineering, Universiti Teknologi MARA (UiTM), Cawangan Johor, Kampus Pasir Gudang, Johor, MALAYSIA.

**Adam Samsudin**, Faculty of Electrical & Electronic Engineering Technology, Universiti Teknikal Malaysia Melaka, Melaka, MALAYSIA. Email: adam.samsudin@utem.edu.my

**Amar Faiz Zainal Abidin\***, Faculty of Electrical & Electronic Engineering Technology, Universiti Teknikal Malaysia Melaka, Melaka, MALAYSIA. Email: amarfaiz@utem.edu.my

**Kamaru Adzha Kadiran**, Faculty of Electrical Engineering, Universiti Teknologi MARA (UiTM), Cawangan Johor, Kampus Pasir Gudang, Johor, MALAYSIA. Email: adzha7379@uitm.edu.my

educational purposes whereby they make case studies in modelling, calibration, sensor and actuator electronic circuits, simulation, PID tuning and real-time control code under a step by step collection schedule [2]. As the result of this laboratory activity, significant progress is observed for the quality, motivation and learning.

## II. LITERATURE REVIEW

The development of electronic quiz board is not something new. M. H. A. H. A. M. Faseh et. al has develop a low cost version of Mneumonic Code translator for Programmable Logic Controller (PLC) subject [3]. M. A. Hairuddin. et. al (2018) has proposed a trainer to teach Industrial Instrumentation subject using LabVIEW integrated with Internet of Things (IoT) platform called Computer Assisted E-Laboratory [4]. The interactive trainer designed for remote access to the equipment as known LD-Didactic temperature system. The integrated LabVIEW, Arduino-Espresso8266 and Blynk Software used to control PID temperature control system. R. Rifin et. al on the other hand has developed a mobile apps called ExamWhiz to simplify the conventional exam works such as building exam questions, marking works and avoiding the wasting of the conventional exam papers [5]. The apps is developed using Java programming base with Eclipse IDE 3.7 which integrated with Tomcat 7 that allows launching application server from Eclipse. M. F. Z. M. Zakaria et. al has proposed an educational quiz board to test students on the subject control systems particularly on the topic that cover principle's second order transient response using speed control of DC Motor as the application [6]. The educational quiz board has used DC motor speed control as the application for the transient response. Questions asked based on the response curve created by the system included the under damped transient response. An educational kit of a traditional board game called Congkak was digitized and called E-Congkak by A. F. Hafizan et al. [7]. An electronic based Reversi is done by I. A. Rozani et al. in order to encourage young kid to play traditional board game [8]. M. R. Yaacob et al. developed e-Flowchart educational kit to help student learn the basic concept of flowchart [9]. M. F. A. M. A. Halim et al. developed a teaching quiz board that test student knowledge on resistors connection [10]. The electronic version of the famous Mastermind game has been showcase as part of CDIO project by R. F.

# E-Water Level: Educational Kit For Testing Student Knowledge on Transient Response using Water Level Control

Mustapa et al. [11]. A. F. Hassan et al. proposed a visual gamification app to accommodate the physiotherapy session [12].

## III. METHODOLOGY

This project uses Arduino Mega 2560 as the microcontroller. Arduino is a complete development platform with its own standards, integrated development environment and programming interface. E-Water Level use water tank as a plant that process happen. The water pump will produce the pump out and pump in through the pipe and the ultrasonic sensor will detect the water level. The water pump will pump out the water using 6V motor pump. When the water level is equivalent or above the set point provided by the question, the relay (Relay 1) for the water flow in will turns off. If there is excessive water, Relay 2 will turns on which force the water to flow out from the tank. The process will continue for 120 seconds and will end after the moment. This project also uses 2.4 inch Thin-Film-Transistor Liquid Crystal Display (TFT LCD) shield to display the result, in term of water level (cm) versus time graph. Based on the data captured, a set of questions consists of delay time, rise time, damping ratio and settling time will be asked to the user. The student can solves the question based on the value that given in the TFT LCD.

Fig. 1 shows the project prototype which consists of keypad for user to enter the answer in term of numerical value. 20×4 LCD is used to display the questions. The user will insert the answers and the feedback from the kit regarding the answered given by the user. The circuit diagram of the educational kit is as shown in Fig. 2. Several pins consist of GND, VCC, AREF, A0-A5 and pin 0-13 of Arduino Mega (2560) is reserved for TFT Shield LCD. LCD 20×4 is connected with I2C. VCC and GND for I2C are connected to Arduino Mega. SDA and SCL for I2c is connected to pin 20 and pin 21 on Arduino Mega. The red Light Emitting Diode (LED) is an indicator that the kit is not ready to accept input from the user. This red LED is connected to pin 47.

On the other hand, the blue LED is an indicator to inform the user that the kit is ready to accept answer for the question. This LED is connected to pin 46. The GND for both red and blue LED are connected to GND Arduino Mega in parallel. The buzzer is used to warn the user when the water pumped in to the tank which is when the starting of the plot graph connected to pin 48 of Arduino Mega. Keypad 4×4 is used to enter the input for the question and answer session where it connected on Arduino Mega which pin 24, 25, 27, 29 (for rows), and pin 31, 33, 35 and 37 (for columns). Relay 1 is at the state of normally open (NO) is connected to the motor pump (motor that pump in water to the main tank) which has 3 pin and connected to GND, VCC and 52 on Arduino Mega. Relay 2 is normally open (NO) is connected to water pump (motor that pump out water to the main tank) which has 3 pin and connected to GND, VCC and 53 on Arduino Mega. The water level sensor, ultrasonic, has 4 pin where GND, VCC, trigger connected to pin A11, echo connected to pin A8. The function of ultrasonic sensor is to detect the water level.



Fig. 1. E-Water level prototype

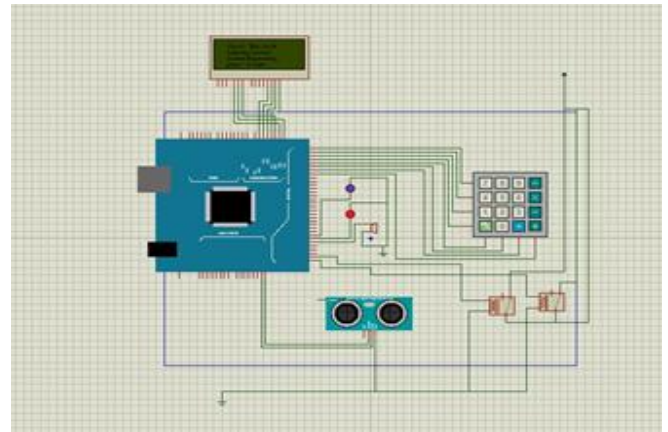

Fig. 2. Schematic Diagram for E-Water level

Fig. 3 until Fig. 5 show the flowchart of E-Water Level operation. First, user is required to press button asterisk "\*" in the keypad to start the process. After pressing it, the process will start empty the tank in order to be in default mode. After the tank is emptied, blue LED will turn on to indicates the water in the tank is empty. Then, the actual process of filling the tank with water until it reaches the set point value will start where water from the reserved tank will pump into the main tank. At every instant of the process, ultrasonic sensor will capture the water level and the kit translates the water level by plotting the water level on a graph of water level in centimeter (cm) versus time in second (s). After 120 seconds, the process will end and red LED will turn on as an indicator. At the end of the process, LCD will display the questions to user based on the information given from the TFT LCD. Fig. 2 shows the flow chart for initial program and first question that asked to find percentage overshoot (%OS). The user will insert the answer and the kit will check the answer based on this definition of maximum peak value of the response curve measured from unity (final value) and percentage of maximum overshoot. The kit will give feedback to the user by informing the user whether the answer is correct or not, and provide the correct answer. The correct answer will increase the user's mark by one, otherwise, no change in the mark. The process will be repeated by the kit by asking the delay time, damping ratio, and natural frequency. The total marks will be display once the user answered all the questions.

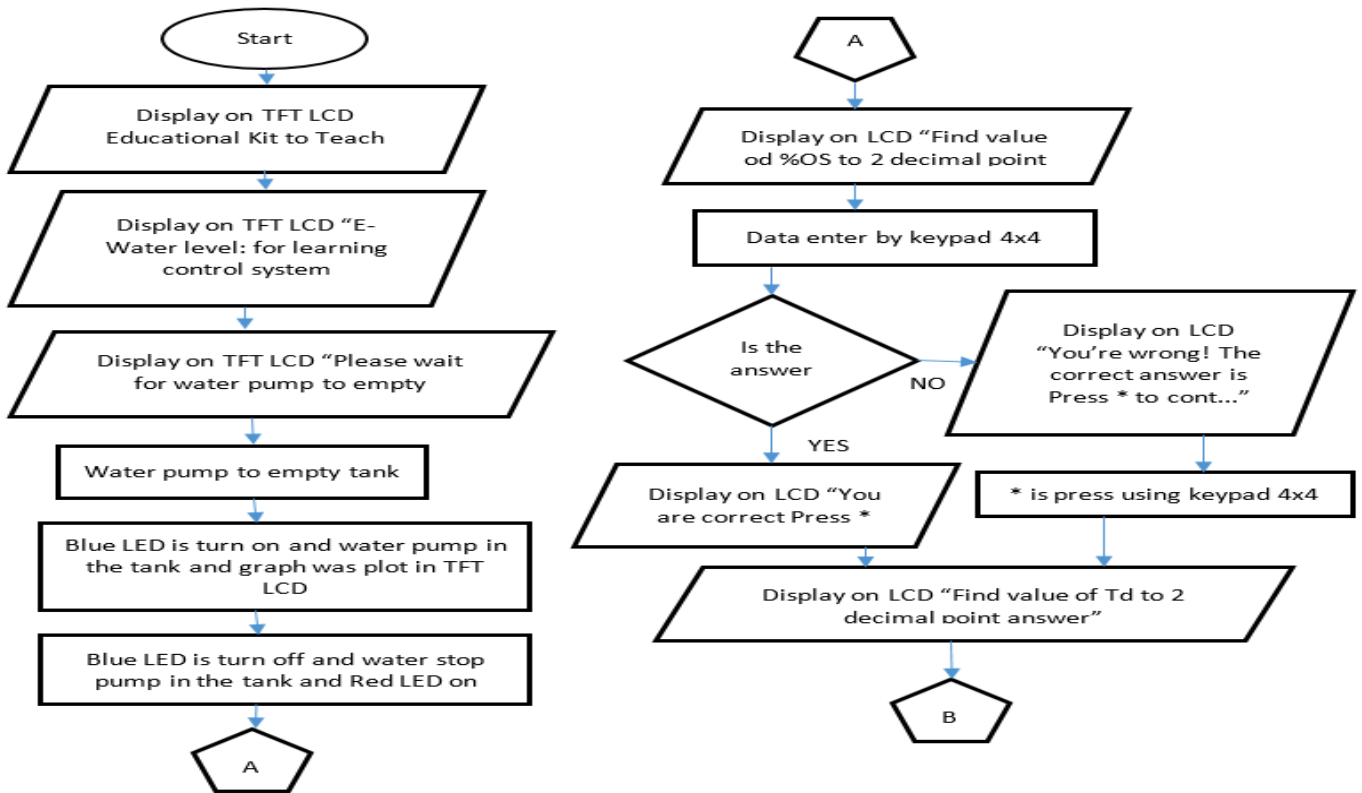

Fig. 3. Flowchart for initial program and finding percentage overshoot and damping ratio values

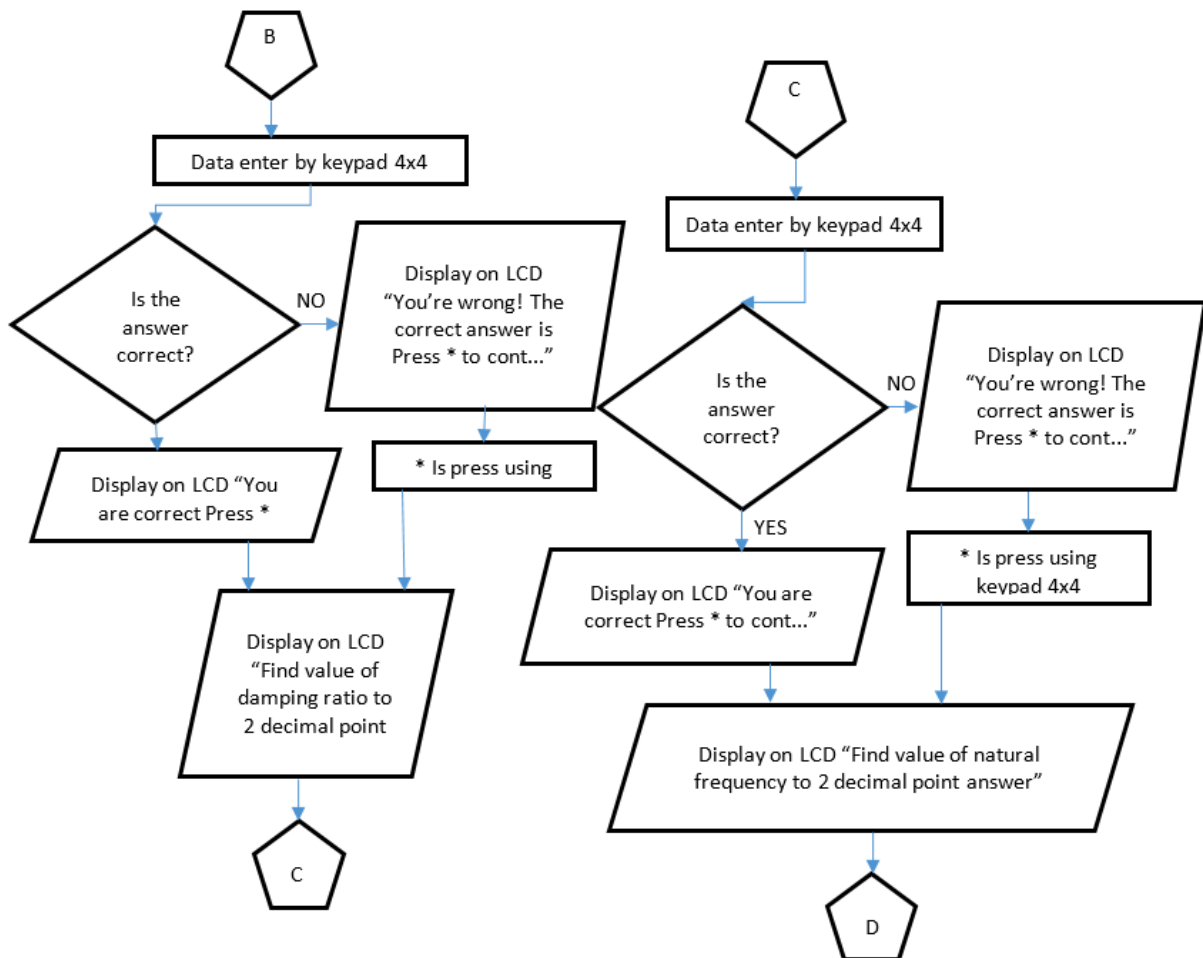

Fig. 4. Flowchart to find the value for damping ratio and natural frequency values.

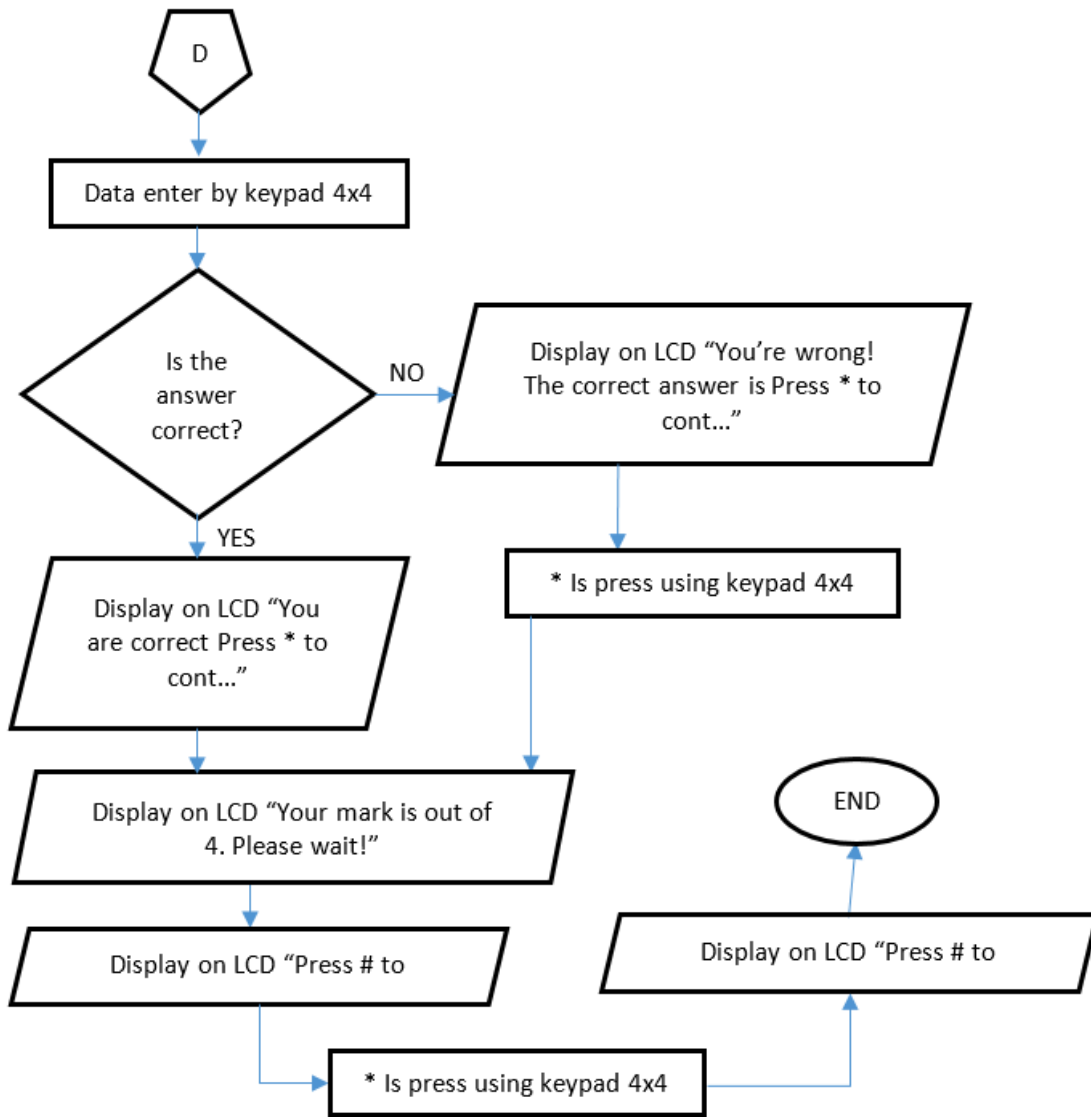

Fig. 5. Flowchart for final question feedback and total marks.

#### IV. RESULT AND DISCUSSION

Fig. 6 (a) shows the graph on TFT LCD with no plotted data while Fig. 6 (b) shows transient response graph with plotted data captured by using the educational kit. The graph is generated on TFT LCD after the pumping process in the tank completed.

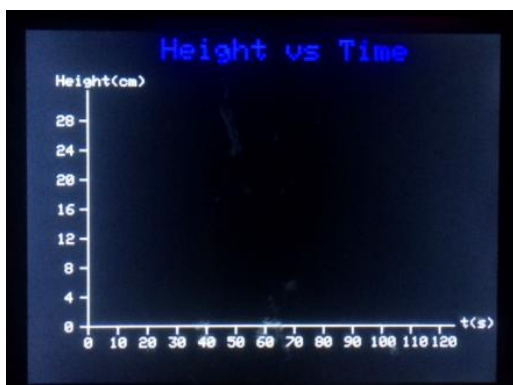

Fig. 6 (a). TFT LCD shows no graph before start the process

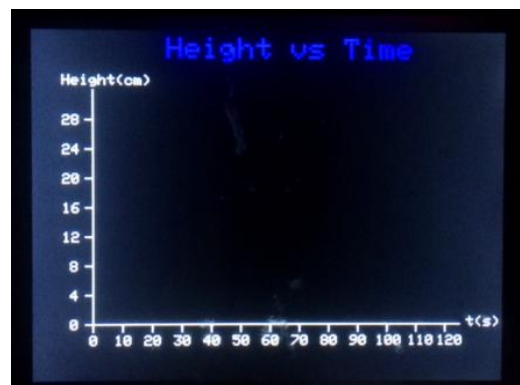
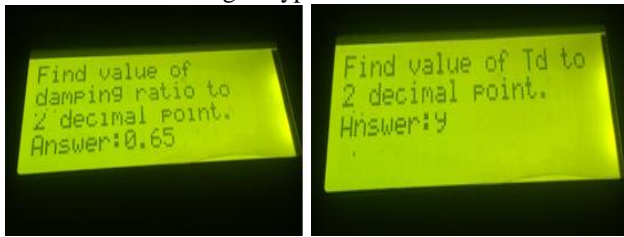

Fig. 6 (a). TFT LCD shows the plotted graph after the complete water pump process

After the graph generated on TFT LCD, the first question appeared on 20×4 LCD is to ask regarding the damping ratio. The user has to enter the numerical value through the keypad for the answer. After that, second question appear to find the value of delay time. User also need to key in the numerical value through keypad for the answer.

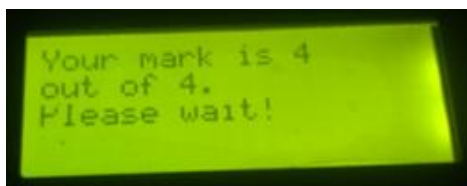

**Fig. 7. Example of questions asked related damping and delay time.**

On Fig. 8, third question asked regarding natural frequency base on the graph while the last question is asked about the overshoot value base on the graph generated. Fig. 9 shows the final step of the process whereby overall marks is given and displayed on 20×4 LCD. One mark is given to each questions correctly answered and zero mark if the answer is wrong.



**Fig. 8. Example of questions asked related to natural frequency and percentage overshoot.**



**Fig. 9. Example of feedback of the final mark obtained by user.**

#### IV. CONCLUSION

This paper presents the development of an electronic-based educational kit for learning control system by using water level application. This E-Water Level kit will generate several questions related to transient response and user will answers accordingly. By having this application, students will get more understanding and relate the real application of transient response with the theory learned from the control principle course. Having said that, the authors believe further analysis need to be done to measure the effectiveness of the prototype.

#### ACKNOWLEDGMENT

The authors would like to thank and gratitude Universiti Teknikal Malaysia Melaka (UTeM) for sponsoring this work under short-term grant no. PJP/2018/FTK(16A)/S01642.

#### REFERENCES

- Bernstein, D.S. (1999). *Enhancing Undergraduate Control Education*, IEEE Control Systems, 40-43.
- Daniel C. Jeronimo, Rejane de Barros Araújo, Antonio A.R. Coelho, Julio E. Normey-Rico (2014). An Approach for Improving Student Performance in a Feedback Systems Course for Process Control Education, *IFAC Proceedings Volumes, Volume 47, Issue 3*(10574-10579).
- Faseh M.H.A.H.A.M., Ismail F.N., Majid M.A., Abidin A.F.Z., Yusoff Z.M., Rifin R., Hasan K.K., Ali N.M. & Rizman Z.I. (2018). "E-PLC: The Development of a Programmable Logic Controller Trainer that Translates Mnemonic Codes to Hardware Simulation", *Journal of Fundamental and Applied Sciences*, 10, 2S. 499-513.
- M. A. Hairuddin, N. D. K. Anuar, Z. M. Yusoff, A. F. Z. Abidin, M. T. Nooritawati (2018). "Computer Assisted E-Laboratory using LabView and Internet-of-Things Platform as Teaching Aids in the Industrial Instrumentation Course," *International Journal of Online Engineering*, 14,12. 26-42.
- Rifin R., Fang T.E., Abidin A.F.Z., Adam A., Majid M.A., Zainuddin A., Mohammad S.H., Harun M.H. & Rizman Z.I. (2018). "Examwiz: A Development and Implementation of an Android Based Examination", *Journal of Fundamental Applied Science*, 10, 6S. 965-976.
- M. F. Z. M. Zakaria, S. A. C. Aziz, A. F. Z. Abidin, M. A. Adip, N. Rahim, W. H. W. Hassan (2018). "The Development of an Electronic Educational Quiz Board that Test Student Knowledge on Control Principle's Second Order Transient Response by Using DC Motor Speed Control as Application", *ARN Journal of Engineering and Applied Sciences*, 13, 13. 4079-4082.
- A. F. Hafizan, A. F. Z. Abidin, N. Z. N. Suhaimi, M. M. Mustam, K. A. Kadiran, S. A. Saleh, W. N. A. Rasid(2018). "E-Congkak: The Development of an Electronic Congkak Board Game to Promote Traditional Board Game to Younger Malaysian Generation," *ARN Journal of Engineering and Applied Sciences*, 13,24. 9624-9630.
- I. A. Rozani, A. F. Z. Abidin, M. S. Karis, M. N. M. Nizam, A. H. Azahar, M. H. Harun, Z. M. Yusoff, K. K. Hassan, B. N. Shah (2019). "E-Othello: The Development of an Electronic-Hardware version of Traditional Othello Board Game," *ARN Journal of Engineering and Applied Sciences*.
- M. R. Yaacob, A. I. M. Diah, A. F. Z. Abidin, K. A. Kadiran, R. F. Mustapa, M. Abdullah, M. I. Ismail, S. N. A. H. Zaiton (2018). "e-Flowchart: An Electronic Educational Quiz Board that Test Student Knowledge on C Programming Concept using Flowchart Command," *ARN Journal of Engineering and Applied Sciences*, 13, 23. 9081-9085.
- Ab Halim, M. F. M., Nor, A. M. M., Badari, A. A. B., Faiz, A., Abidin, Z., Kadiran, K. A., ... & Harun, M. H. Reseducational Kit The Development Of An Electronic Quiz Board That Test Engineering Students Knowledge on Resistors Concept in Electrical Circuit.
- Mustapa, R. F., Abidin, A. F. Z., Amin, A. A. N. M., Nordin, A. H. M., & Hidayat, M. N. (2017, November). Engineering is fun: Embedded CDIO elements in electrical and electronic engineering final year project. In *2017 IEEE 9th International Conference on Engineering Education (ICEED)* (pp. 1-6). IEEE.
- Hasan, A. F., Husin, M. C., Hashim, M. N., Rosli, K. A., Roslim, F. R. A., & Abidin, A. F. Z. (2017, September). Design of robotic leg and physiotherapy (ROLEP) assist with interactive game. In *AIP Conference Proceedings* (Vol. 1885, No. 1, p. 020278). AIP Publishing.

#### AUTHORS PROFILE



**Ezzatul Farhain Azmi** started as a Mathematics lecturer in Universiti Malaysia Pahang in 2013. She migrated to Universiti Teknikal Malaysia Melaka in 2016. She obtained Master of Science (Mathematics) and her Bachelor of Science (Mathematics) both from Universiti Teknologi Malaysia. Her current research interest is on mathematical modelling, artificial intelligence and mathematical analysis.

## E-Water Level: Educational Kit For Testing Student Knowledge on Transient Response using Water Level Control



modeling, numerical methods/ analysis and differential equations

**Adam Bin Samsudin** started as a Mathematics lecturer in Universiti Malaysia Pahang in 2014. He migrated to Universiti Teknikal Malaysia Melaka in 2018. He obtained Master of Science (Engineering Mathematics) and his Bachelor of Science (Mathematics) both from Universiti Teknologi Malaysia. His skills and expertise is in mathematical



swarm intelligence.

**Amar Faiz Zainal Abidin** currently a Lecturer in Universiti Teknikal Malaysia Melaka. Completed his B. from university of Nottingham Malaysia Campus in year 2008 and Master degree from Universiti Teknologi Malaysia in year 2012. Have been teaching for almost 6 years. His current interest is in computer vision, artificial intelligence and



Currently work in Universiti Teknologi MARA Cawangan Johor Kampus Pasir Gudang. His primary interest in Electronic Design.

**Kamaru Adzha Kadiran** graduated from Universiti Teknologi Malaysia in B. Eng. Electrical – Telecommunication (hons) (2004) and M. Eng. Electrical – Electronic and Telecommunication (2006). Membership of IEM. Previous working experience as Failure Analysis and Component Debug Engineer at Intel from 2006 to 2014.