

# **Role of Platelet-Derived Growth Factor Receptor signalling in microglia-mediated neuroinflammation**

Inaugural Dissertation

zur

Erlangung des Doktorgrades  
Dr.nat.med.

der Medizinischen Fakultät  
und

der Mathematisch-Naturwissenschaftlichen Fakultät  
der Universität zu Köln

vorgelegt von

Moyinoluwa Temitope Taiwo  
aus Lagos, Nigeria

Digital Express 24 GmbH & Co. KG, Köln

2020

Betreuer: Prof. Dr. Thomas Langmann

Referenten: Prof. Dr. Hamid Kashkar  
Prof. Dr. Manolis Pasparakis

Datum der mündlichen Prüfung: 02.10.2020

**Printed with the support of the German Academic Exchange Service**

## **DEDICATION**

To my parents, HRH Oba and Olori C.A Taiwo

*“The use of thesis-writing is to train the mind, or to prove that the mind has been trained; the former purpose is, I trust, promoted, the evidences of the latter are scanty and occasional”*

Thomas Albutt

## ABSTRACT

Neuroinflammation, associated with the onset and progression of neurodegenerative events, is predominantly orchestrated by microglia, the resident immune cells of the central nervous system. Microglia-mediated neuroinflammation, thus, results from dysregulation of its physiological functions, which are tightly controlled by several signalling pathways, including growth factor signalling. Despite the involvement of Platelet-Derived Growth Factor Receptor (PDGFR) signalling and microglia in physiologic and pathologic angiogenesis, this signalling remains uncharacterised in microglia. Thus, the role of PDGFR signalling in microglia-mediated neuroinflammatory responses have been investigated using BV-2 microglial cell line. The expression of PDGFs and their receptors were first characterised in microglia using quantitative polymerase chain reaction, immunocytochemistry, and western blot. Microglia functions, PDGF receptor's role and intracellular signal transduction pathways were investigated using recombinant human PDGF ligands.

Resting BV-2 cells expressed *Pdgfa*, *Pdgfb*, *Pdgfc*, *Pdgfra* and *Pdgfr $\beta$*  genes. In Lipopolysaccharide (LPS) activated cells, *Pdgfb* and *Pdgfr $\beta$*  were significantly upregulated and sustained at protein levels, *Pdgfa* and *Pdgfra* were not significantly altered, while *Pdgfc* was significantly downregulated. PDGF induced an amoeboid-like phenotype with concomitant downregulation of the homeostatic gene, P2Y purinoceptor-12 (*P2ry12*); however, migratory and phagocytic capacities were not significantly affected. Also, reactive oxygen species (ROS) levels were significantly decreased with an upregulation of the anti-oxidant genes, glutathione reductase (*Gsr*) and superoxide dismutase 2 (*Sod2*), though, the main ROS generating enzymes, Nicotinamide adenine dinucleotide phosphate (NADPH) oxidases, *Nox1* and *Nox2*, were significantly upregulated. PDGF induced an inflammatory response in BV-2 cells; however, decreasing neurotoxicity effects on 661W photoreceptor cells cultured in microglia conditioned medium. Pharmacological inhibition and RNAi mediated silencing of *Pdgfr $\beta$*  gene reduced both LPS and PDGF-induced inflammatory responses while variable results were seen for *Pdgfra* gene. Using small-molecule kinase inhibitors, a role for phosphatidylinositol-3-kinase/Akt (PI3K/Akt), extracellular-signal-regulated kinase -1/2 (ERK1/2) and c-Jun N-terminal kinase (JNK) pathways were defined in PDGF-induced inflammatory response in BV-2 cells.

These results demonstrate a fundamental regulatory role of autocrine PDGFR signalling in microglia-mediated responses in resting and activated state.

## ZUSAMMENFASSUNG

Neuroinflammation, die mit dem Beginn und Fortschreiten neurodegenerativer Ereignisse verbunden ist, wird überwiegend von Mikrogliazellen, den lokalen Immunzellen des Zentralnervensystems, gesteuert. Eine durch Mikrogliazellen vermittelte Neuroinflammation resultiert aus einer Fehlregulation der physiologischen Zellfunktionen, welche durch mehrere Signalwege, einschließlich die der Wachstumsfaktoren, streng überwacht und gesteuert werden. Es ist bekannt, dass sowohl der PDGFR-Signalweg (Platelet-Derived Growth Factor Receptor) als auch die Mikrogliazellen bei der physiologischen und pathologischen Angiogenese eine Rolle spielen. Bisher ist allerdings unbekannt, welche Rolle der PDGFR-Signalweg in Mikrogliazellen spielt. Daher wurde die Rolle des PDGFR-Signalwegs in der Mikroglia-vermittelten neuroinflammatorischen Reaktionen unter Verwendung der BV-2-Mikroglia-Zelllinie untersucht.

Zunächst wurde die Expression von PDGFs und ihren Rezeptoren in Mikrogliazellen mittels quantitativer Polymerasekettenreaktion, der Immunhistochemie und dem Western Blot Analyseverfahren charakterisiert. Sowohl die Mikrogliazellfunktion, als auch die Rolle von PDGF-Rezeptoren und der intrazelluläre Signalwege wurden unter Verwendung rekombinanter menschlicher PDGF-Liganden untersucht.

Ruhende BV-2-Zellen exprimierten die Gene *Pdgfa*, *Pdgfb*, *Pdgfc*, *Pdgfra* und *Pdgfr $\beta$* . In Lipopolysaccharid (LPS) -aktivierten Zellen waren die Gene, welche für *Pdgfb* und *Pdgfr $\beta$*  codieren, signifikant hochreguliert, blieben auf Proteinebene allerdings konstant. Expression von *Pdgfa* and *Pdgfra* waren nicht signifikant verändert, während *Pdgfc* signifikant herunterreguliert war. PDGF Stimulation induzierte einen amöboid ähnlichen Mikroglia-Phänotypen bei gleichzeitiger Herunterregulierung des homöostatischen Gens P2Y Purinoceptor-12 (*P2ry12*). Die Migrations- und Phagozytenkapazitäten wurden jedoch nicht signifikant beeinflusst. Auch die Konzentrationen an reaktiven Sauerstoffspezies (ROS) wurden durch eine Hochregulation der antioxidativem Genes Glutathionreduktase (*Gsr*) und Superoxid-Dismutase 2 (*Sod2*) signifikant verringert, obwohl die Expression der wichtigsten ROS-generierenden Enzyme, Nicotinamidadeninukleotidphosphat (NADPH) Oxdasen - *Nox1* und *Nox2* - signifikant hochreguliert waren. PDGF induzierte eine Entzündungsreaktion in BV-2-Zellen, verringerte jedoch die neurotoxischen Effekte in 661W-Photorezeptorzellen, die in Mikrogliazellen-konditioniertem Medium kultiviert wurden. Die pharmakologische Hemmung und RNAi-vermittelte Stummschaltung des

Pdgfr $\beta$ -Gens reduzierte sowohl die LPS- als auch PDGF-induzierte Entzündungsreaktionen in Mikrogliazellen, während gleiche Versuche für das Pdgfr $\alpha$ -Gen zu variablen Ergebnissen führten. Mittels der Verwendung von niedermolekularen Kinase-Inhibitoren konnte festgestellt werden, dass Phosphoinositid-3-Kinasen/AKT (PI3K/Akt), extrazelluläre signalregulierte Kinase 1/2 (ERK1/2) und C-Jun-N-terminale Kinasen (JNK) eine Rolle in der PDGF-induzierten Entzündungsreaktion in BV-2-Zellen spielen.

Diese Ergebnisse zeigen eine grundlegende regulatorische Rolle der autokrinen PDGFR-Signalübertragung bei Mikroglia-vermittelten Reaktionen im Ruhezustand und im reaktivem Zustand.



## TABLE OF CONTENTS

|  |     |
|--|-----|
| <b>ABSTRACT</b> .....  | V   |
| <b>ZUSAMMENFASSUNG</b> .....   | VI  |
| <b>LIST OF TABLES</b> .....  | XI  |
| <b>LIST OF FIGURES</b> .....   | XII |
| <b>CHAPTER ONE: INTRODUCTION</b> .....   | 1   |
| 1.1 Role of microglia in central nervous system (CNS) vascular development ... | 1   |
| 1.2 Study aim and objectives .....   | 2   |
| <b>CHAPTER TWO: LITERATURE REVIEW</b> .....                                    | 3   |
| 2.1 Microglia.....   | 3   |
| 2.1.1 Origin, development and maintenance of microglia.....                    | 4   |
| 2.1.2 Physiological functions of microglia .....                               | 7   |
| 2.1.3 Microglia activation in neuroinflammation and neurodegeneration .....    | 9   |
| 2.2 The Platelet-Derived Growth Factor (PDGF) ligands .....                    | 16  |
| 2.2.1 Structure of the genes that encode the PDGFs .....                       | 18  |
| 2.2.2 Expression of PDGFs in cells and tissues .....                           | 20  |
| 2.3 The PDGF receptors .....   | 22  |
| 2.3.1 Structure of the PDGF receptors .....                                    | 24  |
| 2.3.2 Expression of PDGFRs.....  | 26  |
| 2.3.3 Activation of the PDGFRs.....  | 27  |
| 2.4 PDGFR-induced signalling pathways .....                                    | 29  |
| 2.4.1 MAPK pathways .....  | 30  |
| 2.4.2 Phosphatidylinositol-3-kinase (PI3K) pathway .....                       | 38  |
| 2.5 Crosstalk between the signalling pathways.....                             | 43  |
| 2.6 Modulation and regulation of PDGFR signalling.....                         | 43  |
| 2.6.1 Cbl mediated ubiquitination and degradation.....                         | 44  |
| 2.6.2 Dephosphorylation of the PDGFR .....                                     | 45  |
| 2.6.3 Receptor signalling regulation by serine/threonine phosphorylation ..... | 45  |
| 2.6.4 Spatiotemporal cellular regulation of PDGFRs .....                       | 46  |

|   |  |           |
|---|--|-----------|
| 2.7   | Role of PDGFs in physiology and disease .....                            | 47        |
| <b>CHAPTER THREE: MATERIALS AND METHODS .....</b> |  | <b>49</b> |
| 3.1   | Materials.....   | 49        |
| 3.1.1   | Cells.....   | 49        |
| 3.1.2   | Culture media .....  | 49        |
| 3.1.3   | Buffers and solutions .....  | 50        |
| 3.1.4   | SDS-Poly Acrylamide Gel Electrophoresis (PAGE) .....                     | 51        |
| 3.1.5   | Kits.....  | 52        |
| 3.1.6   | Antibodies.....  | 52        |
| 3.1.7   | Primers and probes .....   | 53        |
| 3.1.8   | siRNA sequences .....  | 54        |
| 3.1.9   | General consumables.....   | 54        |
| 3.1.10  | Compounds, chemicals and reagents.....                                   | 55        |
| 3.1.11  | Devices.....   | 56        |
| 3.1.12  | Software .....   | 57        |
| 3.2   | Methods .....  | 57        |
| 3.2.1   | Cell culture.....  | 57        |
| 3.2.2   | MTT cell proliferation and or viability assay .....                      | 60        |
| 3.2.3   | Transcript analysis.....   | 61        |
| 3.2.4   | Small interfering (siRNA)-mediated gene silencing .....                  | 63        |
| 3.2.5   | Protein analysis .....   | 65        |
| 3.2.6   | Microglia functional assays.....   | 68        |
| 3.2.7   | Statistical analysis .....   | 72        |
| <b>CHAPTER FOUR: RESULTS.....</b>                 |  | <b>73</b> |
| 4.1   | Expression of PDGFs and their receptors in murine microglial cells ..... | 73        |
| 4.2   | Effect of PDGF on microglia functional properties.....                   | 75        |
| 4.2.1   | PDGF induced an amoeboid-like phenotype in microglia .....               | 75        |
| 4.2.2   | Effect of PDGF on microglial cell migration .....                        | 76        |
| 4.2.3   | Effect of PDGF on microglia phagocytic capacity .....                    | 78        |

|  |  |            |
|--|--|------------|
| 4.2.4  | PDGF induced an inflammatory response in microglia .....   | 79         |
| 4.2.5  | PDGF decreased intracellular ROS levels.....   | 81         |
| 4.2.6  | Effect of microglia neurotoxicity on neuronal cells.....   | 82         |
| 4.3  | Expression of PDGF receptor- $\beta$ but not receptor- $\alpha$ is induced upon microglia activation ..... | 83         |
| 4.4  | Antibody blockade of microglial PDGFR $\beta$ reduced LPS and PDGF induced inflammatory responses .....    | 84         |
| 4.5  | Effect of PDGF receptor siRNA-mediated gene silencing on LPS and PDGF induced inflammatory responses.....  | 86         |
| 4.6  | PDGF mediated microglial inflammatory response involves MAPK and PI3K/Akt cell signalling pathways.....    | 88         |
| <b>CHAPTER FIVE: DISCUSSION.....</b>                 |  | <b>92</b>  |
| 5.1  | BV-2 cell line and primary cells as models for microglia cultures .....                                    | 92         |
| 5.2  | Effect of BV-2 microglia activation on the expression of PDGF ligands and their receptors .....            | 94         |
| 5.3  | Effect of PDGF on microglia functional properties.....   | 95         |
| 5.4  | PDGF induced an inflammatory response in microglia .....   | 96         |
| 5.5  | Effect of PDGF-mediated decrease in intracellular ROS levels in microglia                                  | 97         |
| 5.6  | Effect of microglia neurotoxicity on neuronal cells.....   | 99         |
| 5.7  | Role of PDGF receptors and downstream signalling pathway in microglia inflammatory responses .....         | 99         |
| <b>CHAPTER SIX: CONCLUSION AND PERSPECTIVE .....</b> |  | <b>103</b> |
| <b>REFERENCES.....</b>                               |  | <b>104</b> |
| <b>APPENDIX.....</b>                                 |  | <b>150</b> |
| <b>ACKNOWLEDGEMENT .....</b>                         |  | <b>152</b> |
| <b>ERKLÄRUNG .....</b>                               |  | <b>153</b> |

## LIST OF TABLES

|                   |   |    |
|-------------------|---|----|
| <b>Table 3.1</b>  | Cell lines and primary cells .....                      | 49 |
| <b>Table 3.2</b>  | Reagents and culture media formula .....                | 49 |
| <b>Table 3.3</b>  | Recipes for buffers and solutions .....                 | 50 |
| <b>Table 3.4</b>  | Recipes for SDS-PAGE gels .....                         | 51 |
| <b>Table 3.5</b>  | Commercially available kits .....                       | 52 |
| <b>Table 3.6</b>  | Primary and secondary antibodies and stains .....       | 52 |
| <b>Table 3.7</b>  | TaqMan (Probe-based) and SYBR® Green primers .....      | 53 |
| <b>Table 3.8</b>  | ON-TARGETplus SMARTpool siRNA sequences.....            | 54 |
| <b>Table 3.9</b>  | Consumables.....  | 54 |
| <b>Table 3.10</b> | Cytokines, compounds, chemicals and other reagents..... | 55 |
| <b>Table 3.11</b> | Laboratory devices .....                                | 56 |
| <b>Table 3.12</b> | Software .....  | 57 |
| <b>Table 3.13</b> | TaqMan qPCR components .....                            | 62 |
| <b>Table 3.14</b> | TaqMan qPCR program.....                                | 62 |
| <b>Table 3.15</b> | SYBR® Green qPCR components .....                       | 63 |
| <b>Table 3.16</b> | SYBR® Green qPCR program .....                          | 63 |

## LIST OF FIGURES

|                    |   |    |
|--------------------|---|----|
| <b>Figure 2.1</b>  | Microglia development. ....   | 5  |
| <b>Figure 2.2</b>  | Microglia maintenance and renewal. ....   | 7  |
| <b>Figure 2.3</b>  | Ontology of the sensome. ....   | 8  |
| <b>Figure 2.4</b>  | Microglia activation in neuroinflammation and neurodegeneration....   | 13 |
| <b>Figure 2.5</b>  | Retina microglia activity.....  | 16 |
| <b>Figure 2.6</b>  | The mammalian PDGFs.....  | 17 |
| <b>Figure 2.7</b>  | Structure of the genes that encode the PDGFs.....   | 19 |
| <b>Figure 2.8</b>  | Simple illustration of the PDGF system. ....  | 23 |
| <b>Figure 2.9</b>  | Structure of PDGFR $\alpha$ and PDGFR $\beta$ .....   | 26 |
| <b>Figure 2.10</b> | Simplified MAPK signalling cascade. ....  | 31 |
| <b>Figure 2.11</b> | Enzymatic activity of PI3K and SHP1/2 with their corresponding substrate.....   | 38 |
| <b>Figure 2.12</b> | Activation and regulation of Akt.....   | 40 |
| <b>Figure 4.1</b>  | Expression of PDGF ligands and their receptors in BV-2 microglial cells. ....   | 73 |
| <b>Figure 4.2</b>  | LPS induced protein expression of PDGF-BB in BV-2 microglial cells ..   | 74 |
| <b>Figure 4.3</b>  | LPS induced PDGFR $\beta$ and p-PDGFR $\beta$ expression in BV-2 microglial cells. ....                               | 75 |
| <b>Figure 4.4</b>  | PDGF induced an amoeboid-like phenotype in BV-2 microglial cells.   | 76 |
| <b>Figure 4.5</b>  | Effect of PDGF on BV-2 microglial cell migration and pro-migratory genes.....   | 77 |
| <b>Figure 4.6</b>  | Effect of PDGF on BV-2 microglia phagocytic capacity.....   | 79 |
| <b>Figure 4.7</b>  | PDGFs upregulated expression of pro-inflammatory genes in BV-2 and primary microglial cells. ....                     | 80 |
| <b>Figure 4.8</b>  | PDGF decreased intracellular ROS levels while inducing expression of NADPH oxidases.....                              | 81 |
| <b>Figure 4.9</b>  | Effect of PDGF-treated BV-2 microglial cells on anti-oxidant genes..  | 82 |
| <b>Figure 4.10</b> | PDGF decreased apoptosis-related caspase 3/7 activity in photoreceptor cells. ....                                    | 83 |
| <b>Figure 4.11</b> | PDGF ligands upregulated receptor- $\beta$ but not receptor- $\alpha$ in both BV-2 and primary microglial cells. .... | 84 |

|                    |   |    |
|--------------------|---|----|
| <b>Figure 4.12</b> | Antibody blockade of microglial PDGFR $\beta$ reduced LPS-induced inflammatory responses. ....  | 85 |
| <b>Figure 4.13</b> | Antibody blockade of microglial PDGFR $\beta$ reduced PDGF-BB-induced Ccl2 target gene expression. ....                                 | 85 |
| <b>Figure 4.14</b> | siRNA-mediated gene silencing of Pdgfr $\beta$ attenuated LPS and PDGF-BB induced inflammatory responses in BV-2 microglial cells. .... | 87 |
| <b>Figure 4.15</b> | PDGF mediated inflammatory response involves MAPK and PI3K/Akt cell signalling pathways. ....   | 89 |
| <b>Figure 4.16</b> | PDGF-mediated induction of inflammatory mediators is inhibited by MEK1/2, JNK and PI3K inhibitors. ....                                 | 91 |

## CHAPTER ONE: INTRODUCTION

### 1.1 Role of microglia in central nervous system (CNS) vascular development

Microglia are the only resident immune cells of the CNS parenchyma under homeostatic conditions (Ransohoff and Cardona 2010; Mrdjen et al. 2018). Derived from yolk-sac macrophages, microglial cells, function in immune regulation, maintenance of homeostasis, tissue development, and wound repair (Arnold and Betsholtz 2013).

During embryonic development, they migrate into the CNS and retinal neuro-epithelium before the emergence of blood vessels (Arnold and Betsholtz 2013). However, soon after colonising the neuro-epithelium, they start to interact with the growing blood vessels in the brain and retina (Cuadros et al. 1993; Kurz and Christ 1998; Herbomel et al. 2001; Chen et al. 2002) at approximately E10.5 (Ginhoux et al. 2010; Schulz et al. 2012) where they tend to affect each other's development as seen from the *ex-vivo* study of Rymo et al., 2011. Since the developing CNS is devoid of an intrinsic vascular system, the development of blood vessels herein is entirely via angiogenesis (Risau 1997; Lee et al. 2009; Eilken and Adams 2010; Vallon et al. 2014) where new capillaries, via pro-angiogenic signals sprout from perineural vessels (Arnold and Betsholtz 2013). Angiogenesis, thus, involves the co-ordinated responses of two primary cells, endothelial cells (ECs) and mural cells [composed of vascular smooth muscle cells (VSMCs) and pericytes] which must undergo migration, proliferation, polarisation for lumen formation and basement membrane deposition (Rymo et al. 2011). During angiogenesis, an endothelial tip-cell (reacting to pro- and anti-angiogenic signals from the surrounding tissue), thus leads each sprout.

Vascular endothelial growth factor-A (VEGFA), the primary pro-angiogenic factor, signals through VEGF receptor- 2 present on tip-cells promoting filopodia formation and extension in the direction of the VEGFA source (Rymo et al. 2011). In addition to VEGFA/VEGFR2 signalling, the PDGFB/PDGFR $\beta$  signalling is also critically involved in recruiting mural cells to newly formed vessels during which time their proliferation is enhanced (Hellstrom et al. 1999; Hoch and Soriano 2003). During the angiogenic process, PDGFB is expressed by the sprouting ECs, and it signals through PDGFR $\beta$  expressed specifically by mural cells which surrounds the blood vessels to provide stability (Lindahl et al. 1997; Annika et al. 2005; Adams and Alitalo 2007). Thus, disruption of the PDGFB/PDGFR $\beta$  signalling results in the diminished capacity to

recruit mural cells thereby contributing to pathologic angiogenesis (Ucuzian et al. 2010). As earlier mentioned that microglia migrate into the CNS and retinal neuro-epithelium before the emergence of blood vessels, this positions them to guide the initial sprouting, migration, connection and refinement of the developing CNS and retina vasculature (Arnold and Betsholtz 2013). This concept of microglia's involvement in CNS vascular development is however strongly supported by angiogenic studies following microglia depletion, or in studies of mice devoid of microglia (Checchin et al. 2006; Kubota et al. 2009).

In line with microglia's important role in retinal angiogenesis (Rathnasamy et al. 2019), blood vessel disruption and blood-brain/retina barrier (BBB/BRB) breakdown in pathological conditions such as in neurodegenerative diseases have been seen to correlate with microgliosis (Matsumoto et al. 2012; Barkauskas et al. 2015). Additionally, in the retina of patients with Age-related Macular Degeneration (AMD), accumulation of microglial cells were seen in the sub-retinal space especially at locations of retinal degeneration and choroidal neovascularization (CNV) (Combadière et al. 2007). Also, in the laser-induced CNV animal model, microglia have been seen at future CNV sites before angiogenesis commenced (Liu et al. 2013) and these cells expressed some pro-angiogenic factors including VEGF and PDGFB (Krause et al. 2014; Li et al. 2017) establishing their role in the induction of pathological angiogenesis (Rathnasamy et al. 2019).

## **1.2 Study aim and objectives**

In light of the involvement of microglia and the PDGFR system in physiologic and pathologic angiogenesis, this study sought to understand the direct association and interaction between microglia and the PDGF/PDGFR system as this remains largely uncharacterised. As such, the aim of this study was to investigate the role of PDGFR signalling in microglia-mediated neuroinflammatory responses *in-vitro*. To achieve this aim, three specific objectives were set:

- i. To characterise the microglia-specific expression of PDGF ligands and their receptors in resting and activated state.
- ii. To study the effect of ligand-mediated PDGFR activation on microglia functional properties.
- iii. To determine the role of each PDGFR in microglia inflammatory responses and to investigate the signalling pathways involved therein.



## CHAPTER TWO: LITERATURE REVIEW

### 2.1 Microglia

Microglial cells were first identified and reported as 'rod cells' ('Staebchenzellen' in German) in 1899 and 1900 by Nissl and Robertson respectively on the basis of their rod-like nuclei shape describing these cells as reactive neuroglia while also noticing that they accumulate at the surroundings of inflammation-induced lesions in the CNS (Gomez-Nicola and Perry 2015; Waisman et al. 2015). These cells were later characterised and distinguished from all other glial cells and was called "microglia" by Pio del Rio-Hortega who also highlighted that these cells had the potential to acquire an amoeboid morphology from a ramified one during pathological conditions (Kettenmann et al. 2011; Gomez-Nicola and Perry 2015).

The glial cells are the third main cells in the CNS besides neurons and vascular cells and they account for more than 90% of these three population of cells (Ransohoff and Cardona 2010; Greter and Merad 2013). Microglia derived from two words 'micro' meaning small and 'glia' meaning glue, are now the third population of glial cells present in the CNS apart from the macroglia which is made up of astrocytes and oligodendrocytes (Greter and Merad 2013; EIAli and Rivest 2016). Therefore, microglial cells are the only cell type in the CNS parenchyma that is neither vascular nor neuronal, instead, they are the resident CNS inflammatory cells (Ransohoff and Cardona 2010).

They are also a member of the mononuclear phagocyte series of cells (comprising of CNS-associated macrophages, peripheral tissue macrophages, monocyte-derived, and dendritic cells) (Prinz et al. 2011; Gomez Perdiguero et al. 2013) but of myeloid lineage (McKercher et al. 1996; Chan et al. 2007; Ransohoff and Perry 2009; Perry et al. 2010; Ginhoux et al. 2010). This makes microglia a special and distinct type of cells in that they are CNS glial cells as well as a unique type of mononuclear phagocyte.

These cells are distributed uniformly all through the brain and spinal cord with higher neuronal nuclei densities, including the substantia nigra in the midbrain (Lawson et al. 1990). Their densities also vary between humans and rodents with minute morphological differences in different cytoarchitectural regions (Lawson et al. 1990). However, depending on the region anatomically, various methods used, health or pathology, microglia account for somewhere between 0.5 and 16.6% of the human brain total cell population (Mittelbronn et al. 2001; Pelvig et al. 2008; Lyck et al. 2009;

Lull and Block 2010) while also varying, depending on the region, at somewhere between 5% in the corpus callosum and 12% in the substantia nigra in the normal adult mouse brain (Lawson et al. 1990).

Morphologically, in the healthy adult mammalian CNS, microglia has a small cell soma, a small perinuclear cytoplasm, and a host of fine, extremely mobile, branched processes covered by fine protrusions (Ransohoff and Perry 2009; Boche et al. 2013; Patro et al. 2016; Salter and Stevens 2017). This morphological state is habitually termed 'ramified', which for a long time has been assumed to reflect a relatively inactive or 'resting' state (Boche et al. 2013). However, with time-lapse *in-vivo* two-photon video microscopy, microglia processes were seen to be constantly in motion (highly mobile), actively surveying their immediate environment (Davalos et al. 2005; Nimmerjahn et al. 2005). This surveillance activity does support the theory of microglia being CNS first line of defense (Kreutzberg 1996; van Rossum and Hanisch 2004).

### **2.1.1 Origin, development and maintenance of microglia**

Prior to the works of Ginhoux et al. 2010 and Schulz et al. 2012, the origin of microglia, has been a controversial subject over years, however the general consensus now is that microglia stem from primitive hematopoietic progenitors (erythromyeloid precursors - EMP) that originate from the extra embryonic yolk sac (Fig. 2.1), a structure believed to be present from a previous stage of embryogenesis (Alliot et al. 1999; Ginhoux et al. 2010; Schulz et al. 2012; Kierdorf et al. 2013; Prinz and Priller 2014). The yolk sac origin of microglia was confirmed in sophisticated genetic fate-mapping experiments in mice (Ginhoux et al. 2010; Schulz et al. 2012). By either inducing Cre recombinase activity from the *Runx* locus (Ginhoux et al. 2010) or from the colony stimulating factor 1 (*Csf1*) receptor locus (Schulz et al. 2012) through tamoxifen injections into pregnant mice between E7.0 and E8.5 (when embryonic hematopoiesis is confined in the yolk sac), these authors discovered that the principal source of microglia were the early yolk sac cells.

Further characterisation of these early yolk sac precursors that gave rise to the brain microglia showed c-kit<sup>+</sup> lineage<sup>-</sup> progenitor cells within the yolk sac with the potential to differentiate into CX3CR1<sup>+</sup> microglia both *in-vitro* and *in-vivo* (Kierdorf et al. 2013). These cells were also shown to give rise to Ter119<sup>+</sup> erythrocytes representing a common EMP in the yolk sac. Subsequently, there is the disappearance of these uncommitted EMPs and immature F4/80<sup>+</sup>CX3CR1<sup>-</sup> and F4/80<sup>+</sup>CX3CR1<sup>+</sup>

macrophages develop, populating the developing brain surface at around E9.0 (Kierdorf et al. 2013). Starting at E8.5, these EMPs journey through the bloodstream to the developing CNS, continuing until the BBB is formed (Alliot et al. 1999; Ginhoux et al. 2010; Schulz et al. 2012; Gomez Perdiguero et al. 2015). These early cells differentiate under the control of transcription factors Pu.1 and interferon regulatory factor-8 (Irf8), where they predominate the developing brain giving rise to embryonic microglia at E9.0 - 9.5 (Ginhoux et al. 2010; Schulz et al. 2012; Kierdorf et al. 2013). Another transcription factor, Runt-related transcription factor 1 (RUNX1) is important in regulating microglia during embryonic development (Ginhoux et al. 2010) (Fig 2.1). An interesting finding was that myeloid precursors from the blood did not substantially contribute to the pool of adult microglial cell after birth, substantiating that the wide majority of adult microglia originate from the yolk sac (Prinz and Priller 2014). After predominating the brain, they are said to be present as a closed, long-lived population under homeostatic conditions segregated from other bone marrow-derived precursors or circulating monocytes by the BBB (Ajami et al. 2007).

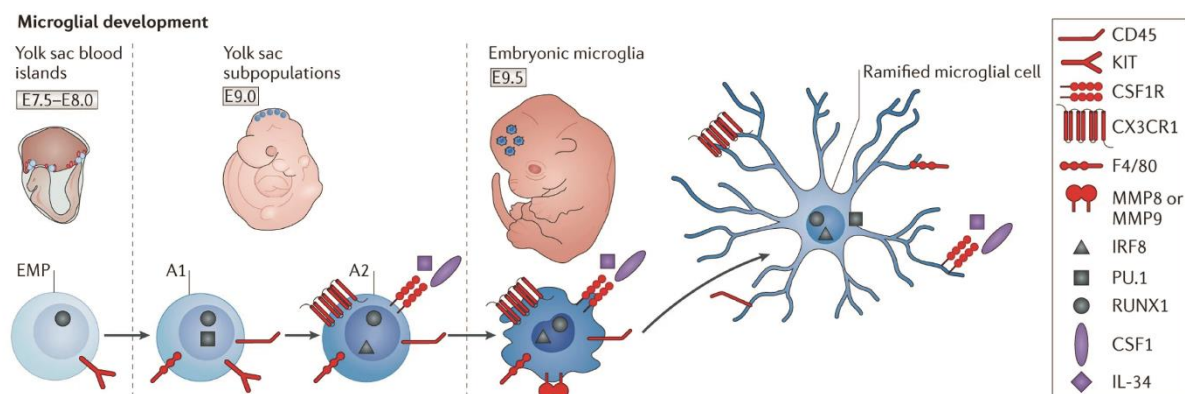

**Figure 2.1 Microglia development.**

The respective symbols (highlighted on the right) as expressed by each population of cell. Microglia derive from immature, uncommitted  $KIT^+$  EMPs originating from the extra embryonic yolk sac at around E7.5 - E8.0 (Kierdorf et al. 2013). A1 cells: upregulation of the CD45 antigen without expression of myeloid markers, A2 cells: expression of myeloid cell markers - CX3C chemokine receptor 1 (CX3CR1), F4/80, and CSF1 receptor (CSF1R). Migrating A2 cells colonise the brain mesenchyme. Image modified and adapted from Prinz and Priller, 2014.

Three main developmental stages of microglia have been identified in mice from yolk sac to adult. Using RNA sequencing and epigenomic analysis to study the transcriptional repertoire dynamics, the stages identified were: early stage (less than

E14), pre-microglia stage (E14 to a few weeks postnatal - P9), and adult microglia stage (more than a few weeks) (Matcovitch-Natan et al. 2016). Similarly, in humans, the same developmental pattern seems to exist where microglia-like cells with diverse morphologies can already be spotted in human fetuses as early as 13 weeks of estimated gestational age (Hutchins et al. 1990). At this period, the cells are denoted 'fetal macrophages' (Lull and Block 2010). These cells have been seen to colonise the spinal cord sometime around 9 weeks where the main microglia entry and distribution begins at around 16 weeks while the distribution of ramified microglia within the intermediate zone take up to 22 weeks (Rezaie and Male 1999, 2002; Rezaie 2003). Actually, it is at 35 weeks (close to term), that well-differentiated microglia populations (with ramified morphology) can be seen in the developing human brain (Esiri et al. 1991; Rezaie and Male 1999; Rezaie et al. 2004; Verney et al. 2010).

Following the establishment of microglia populations, they are said to be maintained within the CNS solely by self-renewal (local proliferation) without the dependence or contribution of blood-monocyte (Ajami et al. 2007; Ginhoux et al. 2010) (Fig 2.2). Thereafter, Schulz et al., 2012, showed that microglia together with other tissue macrophages did not require the transcription factor, Myb, for development finally establishing that the maintenance of microglia is not reliant on hematopoietic stem cells but are continually self-renewed. In the healthy adult mouse brain, individual microglial cells usually live for long periods with a turn-over rate of 0.05% cells per hour (Lawson et al. 1992). However, human microglia averagely live for 4.2 years with a yearly median turn-over rate of 28% meaning that the majority of the microglial cell population is renewed many times during lifetime (Réu et al. 2017).

Thus, microglia maintenance is dependent on CSF1R activation which is also vital for its development as well as for macrophage development (Ginhoux et al. 2010; Erblich et al. 2011). CSF-1 and IL-34, the endogenous ligands for CSFR1, produced by neurons within the CNS during development (Greter et al. 2012; Wang et al. 2012) must therefore be released constantly as the pharmacological blockade of CSF1R has been shown to rapidly deplete microglial cells (Elmore et al. 2014).

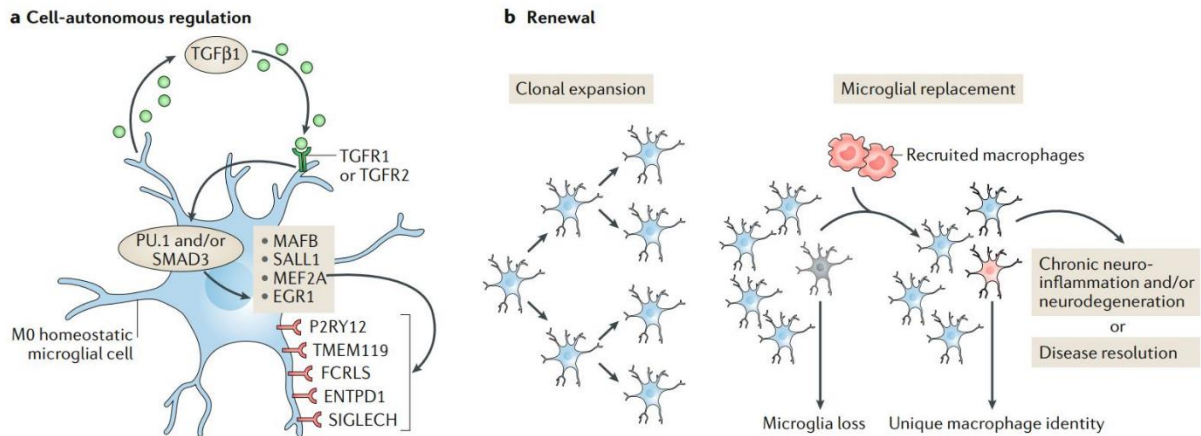

**Figure 2.2 Microglia maintenance and renewal.**

**(a)** Microglia is autonomously maintained via TGF $\beta$ 1, signalling through TGFR1 or 2. TGF $\beta$ 1 controls the transcriptional regulation of genes that encodes the TFs: EGR1, MEF2A, SALL1, and MAFB via PU.1 and or SMAD3 TFs. Microglia are identified by distinct surface receptors such as SIGLECH, ENTPD1, FCRLS, TMEM119, and P2RY12. **(b)** Microglia self-renew through local clonal expansion (Tay et al. 2017). However, peripherally derived macrophages recruited to the CNS can also replace lost microglia under certain conditions. TGF $\beta$ 1 (Transforming growth factor- $\beta$ 1), TGFR1/2 (TGF receptor 1/2), EGR1 (early growth response protein -1), MEF2A (myocyte-specific enhancer factor 2A), SALL1 (Sal-like protein-1), SMAD3 (mothers against decapentaplegic homologue 3), SIGLECH (sialic acid binding Ig-like lectin H, isoform CRA\_a), ENTPD1 (ectonucleoside triphosphate diphosphohydrolase-1), FCRLS (Fc receptor-like S, scavenger receptor), TMEM119 (transmembrane protein-119), P2RY12 (P2Y purinoceptor-12) (Butovsky and Weiner 2018).

### 2.1.2 Physiological functions of microglia

Microglia participate in a number of physiological roles, but in general, their transcriptomes permit them to carry out three important functions: (i) survey their microenvironment, (ii) perform physiological housekeeping, and (iii) host defense. These physiological functions are essential in the different developmental stages from embryonic stage to adulthood to aging. Thus, any functional irregularity causes an imbalance initiating the onset of neurodegeneration (Hickman et al. 2018).

#### Microglia surveillance and monitoring/Sensing:

As earlier mentioned, with *in-vivo* two-photon video microscopy in mice specifically expressing green fluorescent protein (GFP) in microglia, it was seen that microglial cells have highly dynamic processes, that forms a network which spans the CNS and is constantly and actively surveying the microenvironment (Lawson et al. 1990; Davalos et al. 2005; Nimmerjahn et al. 2005). On estimate, resident microglia scan

and survey the whole brain region within a space of few hours and rapidly migrate towards the injurious site or external danger cues (Davalos et al. 2005; Nimmerjahn et al. 2005; Hickman et al. 2018) such as pathogens that invade the brain, or internal danger cues from locally impaired or dying cells (Bessis et al. 2007; Hanisch and Kettenmann 2007). These processes are also in constant contact with axons, neurons and dendritic spines (Salter and Stevens 2017). Approximately about 100 gene products including *AXL*, *P2yr12*, and *MER* are used by microglia processes to sense changes within their immediate environment (their sensome) (Haynes et al. 2006; Hickman et al. 2013; Fourgeaud et al. 2016) (Fig. 2.3). Sensome mRNAs are expressed consistently by microglia in several brain regions, an indication that all microglia have the capability to perform their sensing function. Hence, sensing is necessary for microglia to carry out their function of housekeeping and host defense (Hickman et al. 2018).

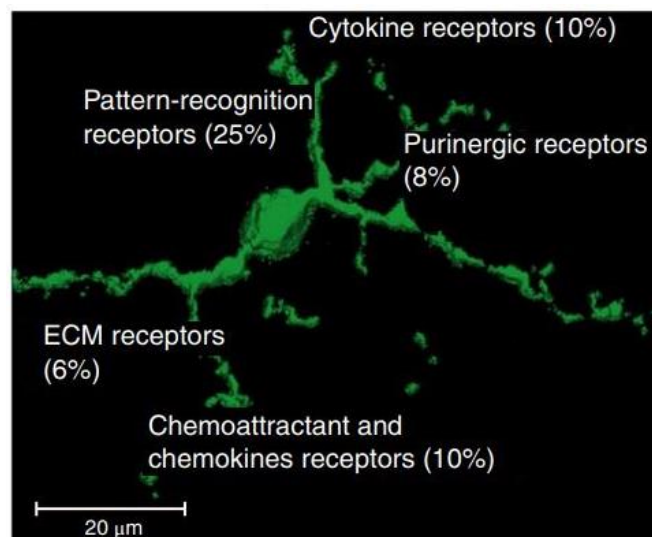

**Figure 2.3 Ontology of the sensome.**

Three-dimensional image of a mouse microglia with an overview of the sensome gene ontology (Hickman et al. 2018).

#### **Housekeeping:**

Microglia are involved in a number of physiological housekeeping functions including; synaptic monitoring and remodeling (Zhan et al. 2014; Lui et al. 2016; Vasek et al. 2016); migration to sites of neuronal death in order to phagocytose dying or dead cells or other forms of debris, including foreign matter and plaques (Fuhrmann et al. 2010; Lull and Block 2010; Krasemann et al. 2017) and myelin homeostasis maintenance (Healy et al. 2016). Microglial cells are also known to engage with astrocytes, an

essential function that is necessary: for homeostasis maintenance, in inflammation, and perhaps neurodegeneration (Liddel et al. 2017). Several genes are involved in these housekeeping functions, amongst them are phagocytosis related genes (scavenger receptors and *Trem2*), genes encoded by chemokine and chemoattractant receptors, and the ones involved in synaptic pruning and remodeling (*C1q* and *Cx3cr1*) (Hickman et al. 2013). Thus, any anomaly with these housekeeping functions can result to neurodegeneration (Krasemann et al. 2017).

#### **Host defense:**

Microglia regulate host defense against pathogens, harmful self-proteins like aggregated  $\alpha$ -synuclein, amyloid beta ( $A\beta$ ), prions, mutant or oxidised superoxide dismutase (SOD), mutant huntingtin, as well as primary or metastatic CNS tumors. Thus, to carry out host defense function, microglia express antimicrobial peptides, viral, Toll-like, and Fc receptors (Hickman et al. 2013). In turn, a neuro-inflammatory response is initiated by microglia in response to these stimuli and in a similar vein to peripheral inflammation, this response involves production of cytokines like IL-1, TNF (El Khoury et al. 2003; Hickman et al. 2008), and chemokines like Ccl2 (El Khoury et al. 2007), to attract additional cells inducing them to get rid of harmful substances and maintain brain homeostasis (Hickman et al. 2018). For instance, monocytes are recruited to the brain by microglia in a Ccl2-dependent manner where they play essential roles in neuro-inflammatory responses, however, they are not part of the resident microglial pool (Ajami et al. 2011).

Thus, when there is a change in microglia homeostasis, tending towards disease-associated phenotype, expression levels of these chemokines including Ccl2 are at their highest. Unlike peripheral inflammation, neuroinflammation can be microglia restricted without attracting other circulating leukocytes. However, unresolved neuroinflammation subsequently induces neurotoxicity, which can lead to neurodegeneration (Hickman et al. 2018).

Other physiological functions of microglia have been extensively reviewed in Boche et al. 2013; Nayak et al. 2014 and Butovsky and Weiner 2018.

#### **2.1.3 Microglia activation in neuroinflammation and neurodegeneration**

Microglial cells are dynamic in nature, constantly responding either slightly or greatly to various signals. In maintaining CNS homeostasis, these cells notably express a category of receptors called the pathogen recognition receptors (PRRs). Examples of

PRRs include; Toll-like receptors (TLRs), Scavenger receptors (SRs), C-type lectin receptors (CLRs), Nucleotide-binding Oligomerization Domain (NOD)-like receptors (NLRs), RIG-I-like receptors (RLRs), and macrophage antigen complex 1 receptor (MAC1R, also called complement receptor 3, CR3) functioning as both a PRR and an adhesion molecule (Block et al. 2007; Rubartelli and Lotze 2007; Colton 2009; Brown and Neher 2010; Figuera-Losada et al. 2014). PRRs are able to recognise molecules released by injured or dying cells known as pathogen-associated molecular patterns (PAMPs) and damage-associated molecular patterns (DAMPs) capable of activating microglia (Rubartelli and Lotze 2007; Colton 2009; Varnum and Ikezu 2012).

Further, microglia has very minimal activation threshold, with activation being very rapid, within a few tens of minutes (Davalos et al. 2005). Thus, their capability to swiftly react to a variety of noxious stimuli and or other potential threats has been referred to as “microglial activation” (Hanisch 2013a). Microglia activation can be induced by PAMPs such as; bacterial, viral, fungal, and parasitic molecules like O-linked mannan,  $\alpha$ - and  $\beta$ -glucan, flagellin, viral RNA and DNA, chitin, and microbial cell wall components. DAMPs capable of inducing microglial activation also include molecules that are not usually present in healthy CNS, such as DNA and RNA released by necrotic cells, blood coagulation factors, antigen-antibody complexes, phosphatidylserine externalised on apoptotic cells, mis-folded proteins or aggregates, and opsonizing complement (Block et al. 2007; Hanisch 2013b).

Microglia activation can also be triggered *in-vivo* by an underlying pathological condition or both *in-vivo* and *in-vitro* by stimulating with cytokines, and other chemical agents (Figuera-Losada et al. 2014) (Fig. 2.4). However, the common method of inducing microglia activation has been with lipopolysaccharide (LPS) (Figuera-Losada et al. 2014) (Fig. 2.4) which has also been used in this study to understand the expression of PDGFRs and their ligands during microglia activation. LPS is a major component of almost all gram-negative bacteria cell wall structure and a well characterised endotoxin which is made of a polysaccharide chain (varying from one gram-negative bacteria to the other) and lipid A (Alexander and Rietschel 2001). LPS recognises and binds TLR4 expressed on microglial cells (Alexander and Rietschel 2001), this association activates the formation of a myddosome, a macromolecular complex, consisting of myeloid differentiation primary response gene 88 (MyD88) and TIR domain-containing adaptor protein (TIRAP) and several members of the interleukin-1 receptor-associated kinase 1 (IRAK) family (Rosadini and Kagan 2017).



Subsequently, this myddosome complex, promotes the activation of downstream kinases including I $\kappa$ B (inhibitor of  $\kappa$ B) and mitogen activated protein kinase (MAPK) which subsequently activates several transcription factors including NF- $\kappa$ B (Nuclear Factor kappa-light-chain-enhancer of activated B cells), AP-1 (Activator protein 1), and the interferon regulator factor (IRF) families. These transcription factors in turn regulate the expression of several genes including those involved in inflammation (Takeuchi and Akira 2010; Rosadini and Kagan 2017).

In general, the extent of microglia activation is dependent on a number of factors like; the nature of insult (or stimuli), duration of the stimuli, factors present within the immediate environment (Stout 2010; Luo and Chen 2012) and microglia “primed” (sensitised) state which renders it more susceptible to a second inflammatory stimulus, thus magnifying the inflammatory response (Perry and Holmes 2014).

A hallmark of microglia responsiveness is therefore the ability of the cells to change their morphology, with or without proliferation (Salter and Stevens 2017). While microglia morphological changes, cell proliferation, migration towards the site of injury or towards dying or damaged cells (to phagocytose) and the expression and or secretion of pro- and anti-inflammatory cytokines have been used to describe microglia activation states (Kraft and Harry 2011; Bazan 2012; Perry and Holmes 2014; Patro et al. 2016), Salter and Stevens, 2017, opined that these changes seen in morphology are only an indication that microglia have detected a homeostatic change; and that they do not define a specific response state neither do they define an activity during any given CNS disease.

During activation, not only do these cells release neurotrophic factors for neuroprotection, they also secrete pro-inflammatory mediators and neurotoxic factors. Secreted neurotrophic factors include brain derived neurotrophic factor (BDNF), nerve growth factor (NGF), glial cell-derived neurotrophic factor (GDNF), and insulin-like growth factor-1 (IGF-1) (Kim and de Vellis 2005; Lu et al. 2005; Block et al. 2007; Thored et al. 2009). Pro-inflammatory mediators include; pro-inflammatory enzymes (e.g., COX-2, iNOS, glutaminase), cytokines (IL-18, IL-1 $\beta$ , IL-6, TNF $\alpha$  etc), chemokines (CCL2, CCL3, CCL4, CCL5, CXCL10 and/or CCL12) while neurotoxic factors include reactive oxygen [superoxide (O $_2^{\cdot-}$ )] and nitrogen [e.g., nitric oxide (NO), peroxynitrite (ONOO $^{\cdot-}$ )] species (Olson and Miller 2004; Akundi et al. 2005; Block et al. 2007; Semple et al. 2010; Bazan 2012; Patro et al. 2016; Takahashi et al. 2016) (Fig. 2.4). Other molecular mediators are also released including interferon (IFN) inducible

protein (IP-10) which promotes an inflammatory state (Frank-Cannon et al. 2009), excitatory neurotransmitters (glutamate), and complement factors (Akundi et al. 2005; Figuera-Losada et al. 2014; Patro et al. 2016).

In addition to the above, their pattern of receptor expression is also altered as a result of cytoskeletal rearrangements (Norden et al. 2015), and their antigen presenting capacity is also increased upon activation, resulting from up-regulation of the major histocompatibility complex-II (MHC-II) antigen (Kreutzberg 1996; Carson 2006; Kettenmann et al. 2011; Gertig and Hanisch 2014). For instance, increase in MHC antigen allows microglia act as antigen-presenting cells to T-cells that will invade the brain during active infections (Aloisi 2001; Bazan 2012). The lipid mediator cascade is also activated, precipitating arachidonic acid (AA) release. Subsequently, the enzymes, lipoxygenases (5-LO and 15-LO) and cyclooxygenases (Cox-1 and Cox-2) readily oxygenate AA forming a sequence of pro-inflammatory eicosanoids [e.g., leukotrienes (LT), prostaglandins (PG), prostanoids, and others] (Akundi et al. 2005; Wang et al. 2005; Bazan 2012). Also, matrix metalloproteinases (MMPs) are activated resulting in increased BBB permeability, thus, allowing local infiltration of neutrophils and other leukocytes, which in-turn secrete more pro-inflammatory mediators, activating microglia further and aggravating the inflammatory response (Bazan 2012). MMP-2 and MMP-9 seem to be the predominant culprits of this process (Agrawal et al. 2006; Webster and Crowe 2006).

All these afore-mentioned responses to microglia activation are what goes on during acute inflammation (Bazan 2012) which in normal physiological state, is transient and somewhat short-lived, effective in getting rid of a host of CNS potential harmful substances. On elimination of the trigger or insult, the inflammation is resolved followed by a return to homeostasis (Bazan 2012) (Fig. 2.4). However, the dysregulation or microglia over-activation and the subsequent inflammation that persist when unresolved have neurotoxic effects that causes neurons and glial cells to decompose and die (Gao and Hong 2008; Frank-Cannon et al. 2009; Lull and Block 2010; Bazan 2012; London et al. 2013) (Fig. 2.4). Thus, when activated microglia accumulate as a response to neuronal damage or from direct over-activity, this process is termed microgliosis (Block et al. 2007). In the end, neuroinflammation becomes a secondary pathological process associated with neurodegenerative diseases (Kim and de Vellis 2005; Frank-Cannon et al. 2009; Ransohoff and Perry 2009; Glass et al. 2010; Gao and Hong 2008) (Fig. 2.4).

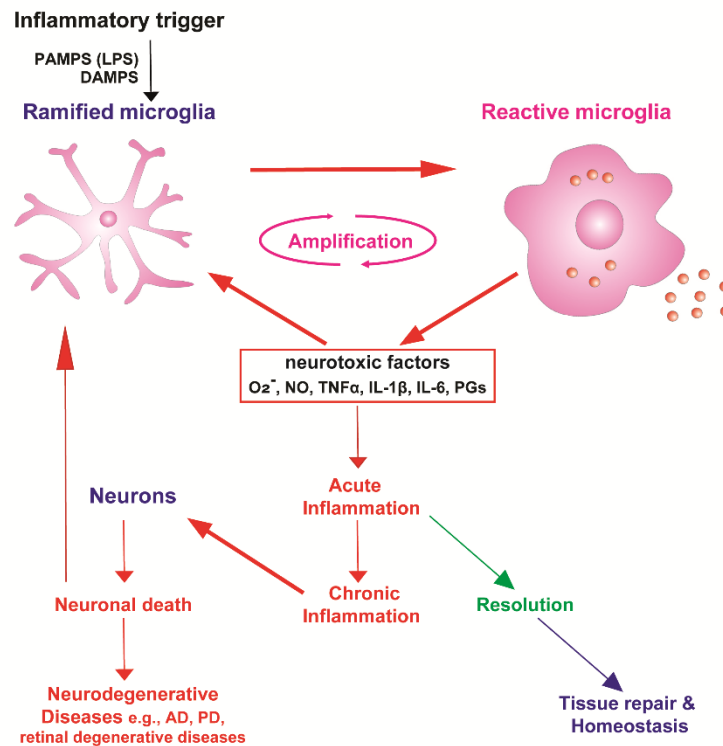

**Figure 2.4 Microglia activation in neuroinflammation and neurodegeneration.** Image modified and adapted from Bazan, 2012. See text for details.

Activated microglia have been identified by numerous methods while their presence has also been established in a number of neurodegenerative diseases such as Amyotrophic Lateral Sclerosis (ALS), Parkinson's disease (PD), Alzheimer's disease (AD), Multiple Sclerosis (MS) (Gao and Hong 2008; Frank-Cannon et al. 2009; Sugama et al. 2009; Bazan 2012; Heppner et al. 2015; Chen et al. 2016), HIV-associated neurocognitive disorder (HAND) (Chen et al. 2017), stroke (Morioka et al. 1993), Huntington disease (Möller 2010), and retinal degenerative diseases like AMD (Penfold et al. 2001; Langmann 2007; Xu et al. 2009; Bazan 2012).

### 2.1.3.1 Microglia in Neovascular AMD

Neovascular AMD (nAMD) (referred to as 'exudative' or 'wet' AMD) is an advanced stage of AMD accounting for about 15% of all AMD cases, but responsible for nearly 90% of vision loss due to AMD cases (Chopdar et al. 2003; Noël et al. 2007).

Neovascular AMD is characterised by pathologic CNV, the in-growth of neovessels from the choroid breaking through the Bruch's membrane into the sub-RPE (retinal pigment epithelium) and or the sub-retinal space, leading to exudation, hemorrhage, pigment epithelial detachment, retinal edema, and fibrous scarring (Ambati et al. 2003; Grossniklaus and Green 2004; Lim et al. 2012) eventually leading to rapid and

permanent central vision loss (Bhutto and Lutty 2012; Yang et al. 2016). CNV is a complex process involving both angiogenesis and inflammation (Campa et al. 2010). While VEGF is the most important contributor to the angiogenesis in CNV (Bhutto and Lutty 2012), the role of PDGF also cannot be downplayed as angiogenesis involves the coordinated activity of both growth factors (Kudelka et al. 2013). The study by Benjamin et al., 1998, provided one of the first leads as to the important role VEGF and PDGF play in nAMD during post-natal retina remodelling examination. Since then, a number of pre-clinical studies have demonstrated the involvement of PDGFR signalling in nAMD. Jo et al., 2006, showed that the combination of anti-VEGF aptamer and APB5, a PDGFR $\beta$  blocking antibody showed lesser NV lesions in comparison to each of the monotherapies in laser-induced CNV mouse model. Similarly, using the same mouse model, Strittmatter et al., 2016, reported the formation of PDGFR $\beta$ <sup>+</sup> scaffold before new vessels infiltrated this scaffold which formed the CNV lesions, while also observing that this scaffold limited the degree of neovascularization. Now, using both genetic and therapeutic approaches, authors showed that the targeting of proliferating PDGFR $\beta$ <sup>+</sup> cells using both methods resulted in the potent inhibition of pericyte-like scaffold formation, with a resultant decrease in CNV.

Accordingly, PDGF has been shown to contribute to the fibrosis part of nAMD pathology (Kudelka et al. 2013). However, anti-VEGF mono therapies are still being used to manage patients presenting with nAMD. These therapies are not curative but only effective in preventing severe vision loss (Scott and Bressler 2013).

While the vascular component that drives angiogenesis in CNV is involved in the development of nAMD, the extra-vascular component that drives the inflammatory process has also been implicated and has been fully elucidated, though, nAMD is said not be a classical inflammatory disorder (Cousins et al. 2004; Spaide 2006; Ding et al. 2009). The vascular component is composed of circulating endothelial progenitor cells, endothelial cells, and pericytes while the invading extra-vascular cells are composed of inflammatory cells like lymphocytes, foreign body giant cells, macrophages, granulocytes, RPE cells, myofibroblasts, fibrocytes, and glial cells (Killingsworth 1995; Grossniklaus et al. 2002; Tsutsumi-Miyahara et al. 2004; Espinosa-Heidmann et al. 2005). Several histopathological studies have linked an increased presence of inflammatory cells to CNV regions (Penfold et al. 2001; McLeod et al. 2016).

Microglia which are the third population of glial cells are also the resident immune cells in the retina (Langmann 2007; Karlstetter et al. 2015). They find their way into the retina during embryological development (Ding et al. 2009). In the healthy adult retina, they reside within the plexiform layers, with their extremely branched morphology and small cell bodies where they are also involved in scanning the retinal environment with their branches (Karlstetter et al. 2015) (Fig. 2.5). They become activated by retinal injury and degeneration as in nAMD (Ding et al. 2009). These reactive microglia multiply, migrate to the injurious site, phagocytose debris, and release pro-inflammatory chemokines, cytokines and neurotoxins (Langmann 2007) (Fig. 2.5).

With respect to nAMD, microglia seen at the sub-retinal space has been shown to probably impact on CNV vascular density (Rathnasamy et al. 2019). Also, in the laser-induced CNV animal model, the most recognised nAMD model (Lambert et al. 2013), microglia were seen at future CNV sites before angiogenesis commenced (Liu et al. 2013) and expressed a number of pro-angiogenic factors including VEGF, fibroblast growth factor 1 and 2 (FGF-1 and 2), PDGFB, and TGF $\beta$ -1 (Krause et al. 2014; Li et al. 2017) (Fig. 2.5) establishing their role in the induction of pathological angiogenesis (Rathnasamy et al. 2019). Besides, the expression of Il-6, ICAM-1 and Ccl2 were reduced upon treatment with an anti-inflammatory carotenoid, astaxanthin, which also subsequently reduced CNV volume (Izumi-Nagai et al. 2008). While the migration of microglial cells to the laser induced-damage site is not fully understood, Huang et al., 2013, proposed that this might be through VEGF receptor activation, as its blockade was shown to inhibit microglia and macrophage infiltration while Rathnasamy et al., 2019, opined that it might be through purinergic receptors expressed by the cells.

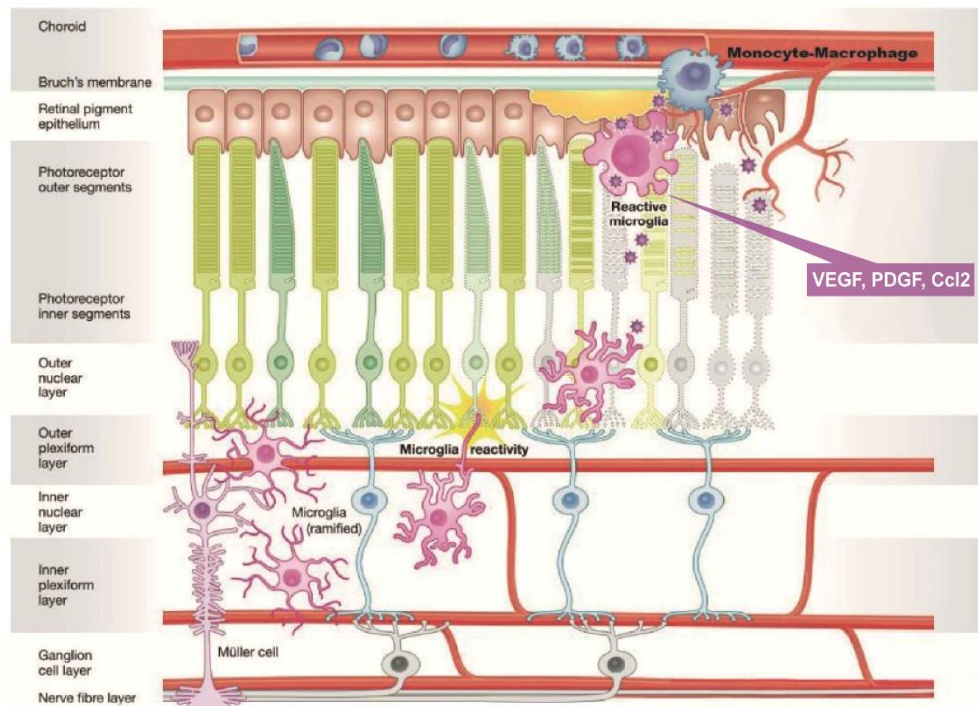

**Figure 2.5 Retina microglia activity.**

Image modified and adapted from Akhtar-Schäfer et al. 2018. See text for details.

Furthermore, in the retina of patients with AMD, accumulation of microglial cells were seen in the sub-retinal space especially at locations of retinal degeneration and CNV (Combadière et al. 2007). Additionally, human eyes affected with nAMD had increased levels of the chemo-attractants, Cxcl10 and Ccl11, that have the capacity to recruit immune cells (Mo et al. 2010).

## 2.2 The Platelet-Derived Growth Factor (PDGF) ligands

The PDGFs are amongst a family of peptide growth factors (that includes the VEGFs) that are related in structure and function (Fredriksson et al. 2004) and are highly conserved throughout evolution (Andrae et al. 2008). The PDGFs are made up of four polypeptide chains of A, B, C and D, encoded by separate genes and regulated independently (Hoch and Soriano 2003; Fredriksson et al. 2004; Raica and Cimpean 2010; Chen et al. 2013; Demoulin and Essagher 2014; Borkham-Kamphorst and Weiskirchen 2016; Papadopoulos and Lennartsson 2018). However, structural differences, as well as differences in proteolytic processing, separate the ligands into two sub-families (Hoch and Soriano 2003). PDGF-A and PDGF-B, referred to as the classical PDGFs were discovered in the 1970s (Betsholtz et al. 1986; Heldin et al.

1986) while PDGF-C and PDGF-D in 2000 and 2001 respectively (Li et al. 2000; Bergsten et al. 2001; Larochelle et al. 2001)(Fig. 2.6).

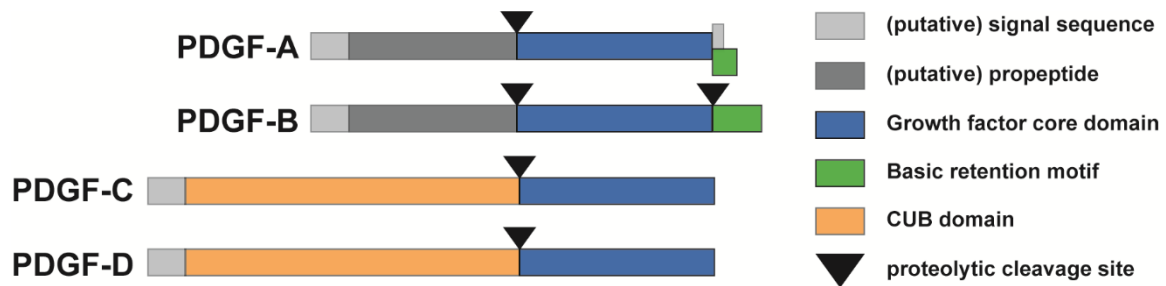

**Figure 2.6 The mammalian PDGFs.**

The classical PDGFs, PDGF-A and -B, have basic retention motifs which differ from the later discovered PDGFs, PDGF-C and -D with CUB domains. Image modified and adapted from Andrae et al. 2008.

The four polypeptide chains form either homo- or hetero-dimers, linked together by disulphide bonds. Five dimeric isoforms have been characterised to date where PDGF-A and -B form both homodimers and heterodimer (PDGF-AA, PDGF-AB, PDGF-BB), while PDGF-C and -D form only homodimers (PDGF-CC and PDGF-DD) (Heldin and Westermark 1999; Heldin et al. 2002; Fredriksson et al. 2004; Kazlauskas 2017). As a result, PDGF-AA or PDGF-BB can be produced by a cell if either of these two genes is primarily transcribed. However, if both genes are simultaneously transcribed, a combination of PDGF-AA, PDGF-BB and PDGF-AB will be formed. PDGF-C has not been reported to form a heterodimer with PDGF-A or PDGF-B (Li et al. 2000), a laudable reason might be that the PDGF-C's core domain is not relatively similar to that of PDGF-A and -B (Betsholtz et al. 2001). On the other hand, PDGF-C and PDGF-D are closely related in structure but also a heterodimer of both isoforms is yet to be reported (Betsholtz et al. 2001).

The PDGFs are known to be extremely stable. Protein denaturation by heat starts at 42°C while heating up to 65°C completely inactivates many restriction enzymes (Kazlauskas 2017). However, the biological activity of PDGF-AB was unaffected, even at 100°C (Antoniades et al. 1979). The intra- and inter-disulphide bonds of the PDGFs which are necessary for their biological activity is said to be partly responsible for this extraordinary stability. Thus, in order of resistance to heat, PDGF-AB exhibits the highest resistance to high temperature, next to PDGF-A and PDGF-B, with more stability than PDGF-C and PDGF-D (Kazlauskas 2017). The PDGFs are functionally relevant at physiological temperature (i.e. 37°C); therefore, their extremely stable

nature remains incompletely understood (Kazlauskas 2017). In line with PDGFRs being able to bind both PDGFs and VEGFA (Ball et al. 2007; Pennock and Kazlauskas 2012), Pennock and Kazlauskas, 2012, speculates that their extreme stability might be a reflection of their clear-cut structure, which therefore allows PDGFRs to differentiate between its ligand (that binds and activates) and VEGF, which merely binds but results neither in PDGF receptor dimerization nor efficient activation.

### **2.2.1 Structure of the genes that encode the PDGFs**

The genomic structures of the PDGF genes are illustrated in figure 2.7. The four PDGF genes are similarly organised, especially the exons that code for the growth factor domain (GFD) which are involved in dimerization, receptor binding and activation (Fredriksson et al. 2004; Borkham-Kamphorst and Weiskirchen 2016) (Fig. 2.7). The PDGF genes (A to D) are located on chromosomes 7, 22, 4 and 11 in humans, and chromosomes 5, 15, 3 and 9 in mice, respectively (Dalla-Favera et al. 1982; Swan et al. 1982; Betsholtz et al. 1986; Uutela et al. 2001; Kazlauskas 2017).

PDGF-A is synthesised as polypeptides of 196 and 211 amino acid residues owing to differential splicing of the transcript (Fig. 2.7) while PDGFB chain is 241 amino acids and PDGFC, and PDGFD chains are 345 and 370 amino acid residues in length respectively (Fredriksson et al. 2004). PDGF-A and -B are closely related structurally. There are seven exons in both *Pdgfa* and *Pdgfb* genes while exon one codes for the hydrophobic signal sequence, exons two and three code for the precursor sequences N-terminal of the GFD which all (exons one, two and three) undergo intracellular processing proteolytically in the *trans*-Golgi network prior to secretion (Fredriksson et al. 2004). Exons four and five, on the other hand, codes for the GFD, and exon six codes for the carboxyl-terminal (C-terminal) sequences which are processed proteolytically when the proteins mature and are released from the extracellular matrix (Fredriksson et al. 2004). Two different splice isoforms of the A-chain is expressed with or without the exon six-encoded sequence. Exon 7 in both of these genes, is primarily non-coding (Li and Eriksson 2003; Fredriksson et al. 2004).

Human *Pdgfc* and *Pdgfd* genes are also structurally similar (Fredriksson et al. 2004) with approximately 50% amino acid sequence identity with each other in the PDGF/VEGF domain (GFD) while PDGFD shows 20-23% genomic sequence identity (with respect to exon numbers and sizes) with the classical PDGFs (PDGFA and PDGFB) and VEGFs in the core domains (GFD) (Bergsten et al. 2001; Fredriksson et



al. 2004) (Fig. 2.7). PDGFC is made up of six coding exons that codes for a 345 amino acid protein, while an extra exon is present in *Pdgfd* gene making it seven exons. In both genes, exon 1 codes for the signal peptide, while exons 2 and 3 codes for the 110 amino acid CUB domain (Fredriksson et al. 2004; Lei and Kazlauskas 2008). Exon 4 in the *Pdgfc* gene codes for the hinge region (of 70 amino acids) between the two structural domains in the growth factor while two exons, exons 4 and 5, codes for the equivalent region in *Pdgfd* gene (Li and Eriksson 2003; Fredriksson et al. 2004; Lei and Kazlauskas 2008). Thus, exons 5 and 6 codes for the 115 amino acid GFD in the *Pdgfc* gene, while exons 6 and 7 codes for the equivalent region in *Pdgfd* gene (Li and Eriksson 2003; Fredriksson et al. 2004; Lei and Kazlauskas 2008). In PDGFC, no alternatively spliced transcript has been identified, however, in PDGFD, an alternatively spliced mRNA that encodes the CUB domain and partly the GFD has been identified in mouse only (Zhuo et al. 2003).

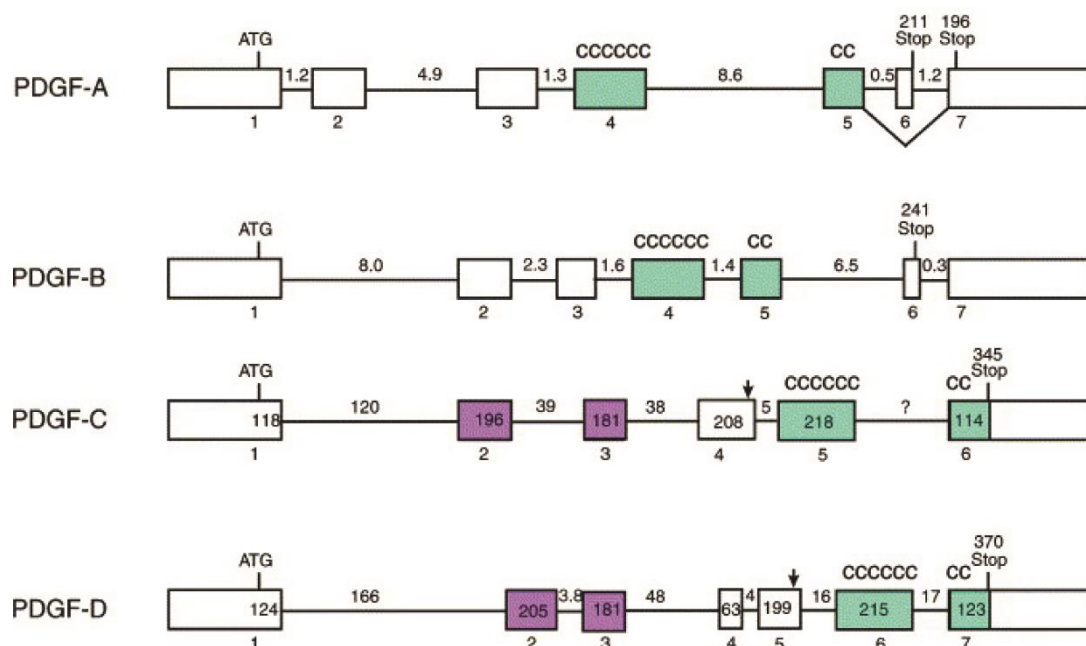

**Figure 2.7 Structure of the genes that encode the PDGFs.**

The open boxes represent the exons with the base-pair length marked inside. The exons that encode the VEGF/PDGF domains are green while those that encode the CUB domains are in purple. The solid lines represent the introns with their respective lengths written on the top. The drawings of the introns and exons are not to scale. Also indicated are the start (ATG), and stop codons (STOP) together with the polypeptide length (amino acid residues written on top of the stop marks). Additionally, two stop codons are indicated for PDGFA due to alternative splicing while the arrows in PDGF-C and PDGF-D indicate the recognised proteolytic cleavage sites. Image modified and adapted from Li and Eriksson, 2003.

As earlier mentioned, all four genes are structurally similar; however, there exist some differences.

Firstly, PDGF-A and -B have short N-terminal extensions while both PDGF-C and PDGF-D, as part of their N-terminal extensions carry a distinct protein domain, the auto-inhibitory CUB domain (Complement subcomponents C1r/C1s, Urchin EGF-like protein and Bone morphogenic protein 1) (Li and Eriksson 2003; Fredriksson et al. 2004; Andrae et al. 2008; Lei and Kazlauskas 2008).

Secondly, in contrast to PDGF-A and PDGF-B, the CUB domains of PDGF-C and PDGF-D do not undergo intracellular proteolytic processing before secretion, but are maintained on them and secreted as latent factors (Betsholtz et al. 2001; Andrae et al. 2008) requiring extracellular proteolysis by proteases such as urokinase plasminogen activator (uPA), tissue plasminogen, matriptase or plasmin before receptor binding and activation can take place (Li et al. 2000; Fredriksson et al. 2004; Lei et al. 2008; Riehle et al. 2014). CUB domains are most commonly found in membrane-associated and extracellular proteins and are developmentally controlled. They are known to modulate extracellular binding in addition to mediating protein-carbohydrate and protein-protein interactions (Bork and Beckmann 1993; Lei and Kazlauskas 2008). However, with PDGF-C and D, these domains tend to prevent activation of PDGFRs while with the VEGF family, the domains facilitate ligand and receptor interaction (Lei and Kazlauskas 2008).

Thirdly, in the C-termini, the classical PDGFs have the basic sequences necessary for extracellular matrix binding while both PDGF-C and PDGF-D are devoid of these amino acid sequence extensions (Fredriksson et al. 2004) instead they have a C-terminal PDGF/VEGF domain, that is separated by a hinge region, a region less conserved structurally in the range of 80 - 100 amino acid residues in length (Li and Eriksson 2003; Rönstrand 2010).

Lastly, the intron sizes between the classical and the later discovered PDGFs differ remarkably. While the genes that code for the classical PDGFs are approximately 20 kb of genomic DNA, those that code for the later discovered PDGFs are approximately 200 kb of genomic DNA (Li and Eriksson 2003; Fredriksson et al. 2004).

### **2.2.2 Expression of PDGFs in cells and tissues**

A variety of diverse cell population is known to express the PDGFs physiologically, where they locally act to mediate different cellular responses (Heldin and Westermark

1999; Andrae et al. 2008). *In-vivo*, expression levels are spatiotemporally regulated and show plasticity during developmental stages as well as in specific physiological hypertrophic responses (Andrae et al. 2008). Expression of PDGF in cultured cells is also known to be dynamic and respond to various stimuli, including thrombin (Daniel et al. 1986; Harlan et al. 1986), hypoxia (Kourembanas et al. 1997), cytokines, and growth factors, including PDGF itself (Heldin and Westermark 1999).

A detailed expression pattern of each of the ligands is quite complex and have been reviewed in-depth (Heldin and Westermark 1999; Hoch and Soriano 2003). However, there is an overall expression pattern. PDGF-B expression is mostly seen in megakaryocytes, neurons, and vascular endothelial cells. A comprehensive analysis of PDGFB/R $\beta$  expression in wild-type embryos and young pups showed that endothelium of growing arteries and sprouting, immature, capillary endothelium have the highest expression of PDGFB (Hellstrom et al. 1999). In tissues, highest expression has been seen in the placenta and heart with other organs expressing moderate levels (Fredriksson et al. 2004). PDGF-A and PDGF-C expression have been seen in muscles, epithelial cells, and neuronal progenitors with these expressions partially overlapping (Lindahl et al. 1997; Betsholtz 2003; Andrae et al. 2008). In tissues, PDGF-A expression is highest in skeletal muscle, pancreas and heart (Fredriksson et al. 2004) while increases in PDGFA expression have also been seen in human uterine SMCs during the physiological hypertrophy of pregnancy (Mendoza et al. 1990). Expression of PDGFC is seen in most adult tissues in humans with the highest expression in the kidney, pancreas, and heart with lower levels in ovary and liver, however, no expression could be detected in spleen, colon or peripheral blood leukocytes (Fredriksson et al. 2004). PDGF-A and -C have also been seen to be co-expressed in the brain, heart, testis, kidney and liver (Fredriksson et al. 2004).

Expression of PDGFD has not been well characterised, but have been reported in most adult tissues in mouse, rat and human (Bergsten et al. 2001; Laroche et al. 2001). The expression has been reported in all three vascular layers (tunica adventitia, tunica media, and tunica intima - endothelium), in VSMCs, ECs and fibroblasts (Uutela et al. 2001; Chen et al. 2005; Andrae et al. 2008; Karvinen et al. 2009). Expression in fibroblasts is probably suggestive of autocrine signalling with PDGFR $\beta$  (Uutela et al. 2001; Andrae et al. 2008). In tissues, expression was highest in the pancreas, ovary,

heart, and adrenal gland with none detected in skeletal muscle, lung nor in the brain (Larochelle et al. 2001; Fredriksson et al. 2004).

In the healthy murine retina, expression of PDGF-A and -B have been seen in retinal ganglion cells/nerve fibre layer as well as in horizontal and amacrine cells (Cox et al. 2003). Expression of PDGFA has also been reported in adult retinal vasculature (Robbins et al. 1994) although its expression seems to be restricted to retinal neurons during development (Mudhar et al. 1993).

### **2.3 The PDGF receptors**

The PDGFs exert their biological activity by binding to two structurally similar but distinct cell-surface (transmembrane) receptor tyrosine kinases (RTKs), PDGFR $\alpha$  and PDGFR $\beta$  which both belong to the class III RTKs including c-FMS, c-KIT, and FLT3 (receptors of CSF1, stem cell factor - SCF, and FLT3-ligand respectively) (Heldin and Westermark 1999; Blume-Jensen and Hunter 2001; Lemmon and Schlessinger 2010; Raica and Cimpean 2010; Rönnstrand 2010; Demoulin and Essaghir 2014; Borkham-Kamphorst and Weiskirchen 2016). The RTKs catalyse the transfer of phosphate groups from ATP (phosphate donor) to tyrosine residues on protein substrates. In the human genome, of the 90 tyrosine kinases identified, 58 are receptor types, and 32 are non-receptor types (Robinson et al. 2000).

The PDGF receptors, alpha and beta, have molecular sizes of approximately 170 and 180 kDa respectively following glycosylation (Yarden et al. 1986; Claesson-Welsh et al. 1989; Matsui et al. 1989). The genes encoding the PDGFR alpha and beta are located on chromosome 4 and 5 in humans (Yarden et al. 1986; Spritz et al. 1994) and 5 and 18 in mice (Kazlauskas 2017) respectively. These receptors are more distant in relation to VEGF and FGF receptors (Demoulin and Essaghir 2014). Though the PDGFRs are structurally similar, they differ in their expression patterns, ligand-binding specificities, and physiological roles (Betsholtz et al. 2001; Ostman and Heldin 2007; Rönnstrand 2010).

These two receptor isoforms form dimers upon binding of the PDGF dimer and depending on the configuration of the ligand and the receptor expression pattern, three receptor combinations are possible:  $-\alpha\alpha$ ,  $-\beta\beta$  and  $-\alpha\beta$  (Bishayee et al. 1989; Heldin et al. 1989; Seifert et al. 1989; Andrae et al. 2008) (Fig. 2.8).

In theory and in general, based on cell culture experiments, multiple and complex PDGF-PDGFR interactions are possible (Fig. 2.8).

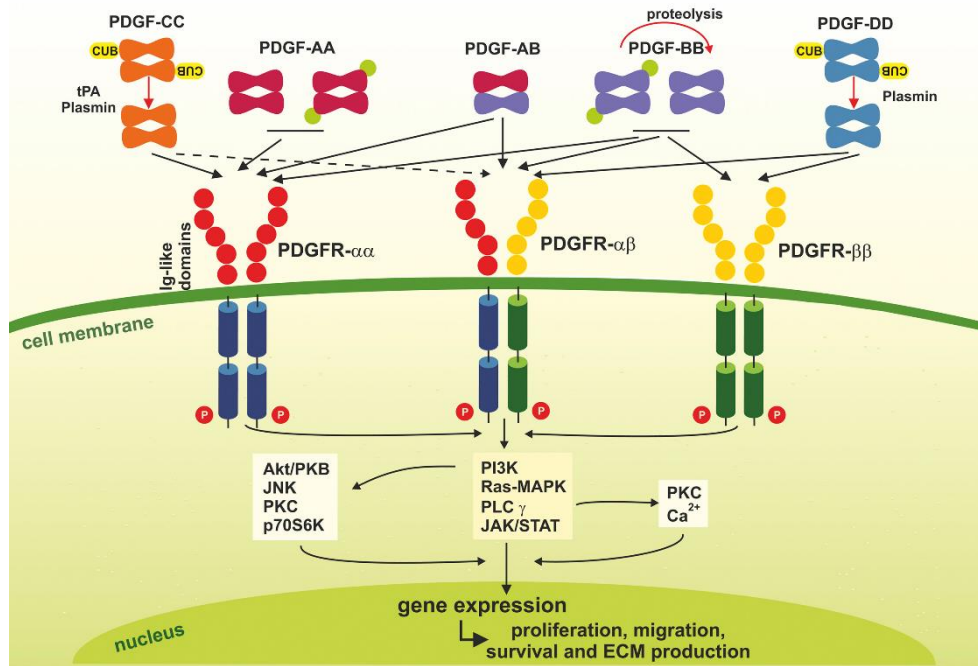

**Figure 2.8 Simple illustration of the PDGF system.**

(Borkham-Kamphorst and Weiskirchen 2016). See text for details.

PDGF-AA binds only to PDGFR- $\alpha\alpha$  whereas PDGF-BB has the ability to bind both PDGFR- $\alpha$  and - $\beta$  thereby making it the only PDGF ligand with the ability to bind to all of the three receptor combinations with high affinity (Hart et al. 1988; Fredriksson et al. 2004). PDGF-CC binds to PDGFR- $\alpha\alpha$  and - $\alpha\beta$ , but does not bind to PDGFR- $\beta\beta$ , thus resembling PDGF-AB (Li et al. 2000; Gilbertson et al. 2001). However, the physiological relevance of PDGFR- $\alpha\beta$  heterodimer activation has not been established to date but studies report that this activation may be responsible for data that shows PDGF-CC to be more potent than PDGF-AA (Li and Eriksson 2003). In the chick embryo chorioallantoic membrane (CAM) and mouse corneal model of angiogenesis, PDGF-CC exhibited more potent angiogenic activity than PDGF-AA (Cao et al. 2002), likewise, amongst the tested ligands, PDGF-CC showed the highest potential as a mitogen on several mesenchymal cell lines (Gilbertson et al. 2001). The binding constant for PDGF-CC binding to PDGFR- $\alpha\alpha$  is said to be similar with PDGF-AA and PDGF-BB (Li and Eriksson 2003). PDGF-DD binds to PDGFR- $\beta\beta$  with high affinity, but it is also able to bind to PDGFR- $\alpha\beta$  but with relatively lower affinity as such it is being referred to as PDGFR- $\beta\beta$  specific (Bergsten et al. 2001; Larochelle et al. 2001). PDGF-D has been reportedly shown to bind PDGFR $\alpha$ , inducing receptor endocytosis, which decreases significantly PDGFR $\alpha$  availability. PDGF-D thus activates PDGFR $\alpha$

specific Tyr754 and Tyr1018 phosphorylation and the adaptor protein that specifically associates with activated PDGFR $\alpha$ , CrkII. The recombinant PDGFR $\alpha$ -Fc chimera homodimer also binds to PDGF-D thereby preventing PDGF-D signalling (Borkham-Kamphorst et al. 2015).

Taken together, all the PDGF dimers except PDGF-DD (PDGF-AA, PDGF-BB, PDGF-CC and PDGF-AB) can bind to PDGFR $\alpha$ , while PDGF-BB and PDGF-DD binds to PDGFR $\beta$  (Heldin and Lennartsson 2013; Demoulin and Essaghir 2014) .

### **2.3.1 Structure of the PDGF receptors**

The structure of the PDGFR family is characteristic of the RTKs which consists of; a ligand binding domain extracellularly; a single transmembrane helix which transmits information from outside into the cell and intracellularly; a juxtamembrane segment (JM), that reduces tyrosine kinase domain basal activity, a split tyrosine kinase domain in the cytoplasmic region (which has a specific inserted sequence of around 100-amino acid residues with no resemblance to kinase domains) responding to extracellular cues, and undergoing phosphorylation to induce downstream signalling events and last, a carboxyl-terminal tail (Heldin and Westermark 1999; Hoch and Soriano 2003; Hubbard 2004; Ostman and Heldin 2007; Andrae et al. 2008; Chen et al. 2013; Eger 2016; Kazlauskas 2017) (Fig. 2.9).

The extracellular part of the receptors consists of five immunoglobulin-like domains (D1-D5) of which domains 2 and 3 are most important for ligand binding (Heidaran et al. 1990; Lokker et al. 1997; Miyazawa et al. 1998; Shim et al. 2010) while domains 4 and 5 participate in receptor dimer stabilisation (Omura et al. 1997; Yang et al. 2008) (Fig. 2.9). Receptor dimer stabilisation is however important because the receptors can attain an orientation that facilitates their activation by trans auto-phosphorylation (Heldin and Lennartsson 2013).

The single transmembrane helix present in each receptor probably functions to relay information from the D4 and D5 domains to the intracellular part. In both receptors, the linkers present between the transmembrane helix and the D5 domain are just 3-4 amino acids in length which suggests that the two transmembrane helices from the dimerized receptors are not likely by geometry to form inter-helix interactions as a result of the D5 domains not being too close to clash into each other (Chen et al. 2013).

Between the transmembrane helix and the kinase domain is the juxtamembrane

segment, a polypeptide of approximately 40 amino acids in length which maintains the kinase domain in an auto-inhibited state until ligand binding activation (Chan et al. 2003; Griffith et al. 2004; Walter et al. 2007). The JM segment contains several tyrosines conserved in all of the class III RTKs saddled with the responsibility for attaching the segment to the kinase domain. Most important is that phosphorylation of these conserved tyrosines results in constitutively activating PDGFR $\beta$  (Mori et al. 1993). Chen et al. 2013, also noted that the addition of phosphate groups to these tyrosines likely prevents the JM segment from binding to the kinase groove, with the same tyrosines likely to be involved in the ligand-induced activation of the PDGFRs. Mol et al. 2003, also noted that trans auto-phosphorylation of these tyrosines could be responsible for kinase domain activation as seen with c-KIT.

The tyrosine kinase domain is the effector domain in these receptors. Together with the phosphorylated tyrosines in the JM segment, the kinase domain of these receptors also harbor two major tyrosine auto-phosphorylation sites, one of which is Y751 in PDGFR $\beta$ , which is found precisely in the insert region within the kinase (Kazlauskas and Cooper 1989). These tyrosine phosphorylation thus provides docking sites for downstream signalling molecules (Kazlauskas and Cooper 1990; Escobedo et al. 1991).

At the C-terminus of the encoding sequences, both receptors possess a highly acidic region, rich in serine and threonine (Fig. 2.9). These sequences participate in ubiquitination and receptor down-regulation (Lennartsson et al. 2006).

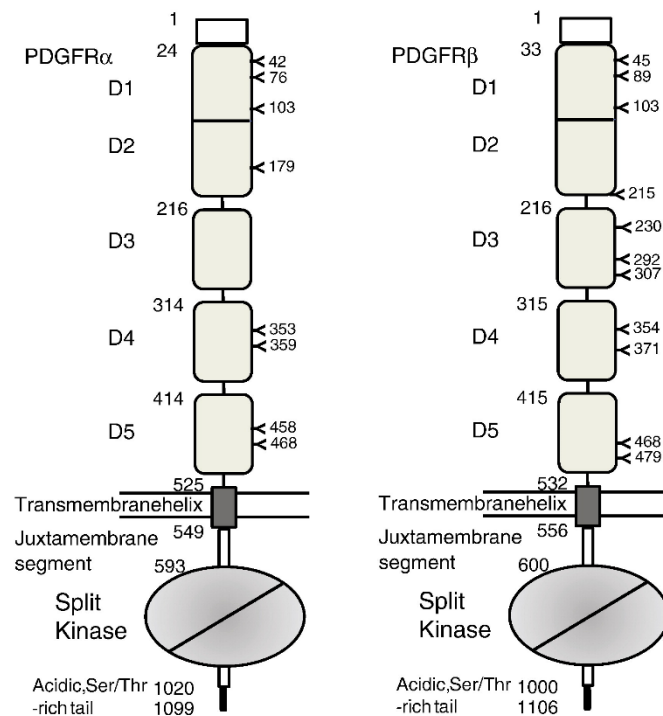

**Figure 2.9 Structure of PDGFR $\alpha$  and PDGFR $\beta$ .**

The different domains (D1-D5) and their compositions are shown. All numbers are for human PDGFRs. The two straight lines represent the lipid bilayer. Note that domains 1 and 2 (D1 and D2) are an integral module while the intracellular kinase domain is a split domain having an insert between the N- and C-terminal lobes (Chen et al. 2013).

### 2.3.2 Expression of PDGFRs

While the pattern of expression of the two PDGFRs are not similar (Kazlauskas 2017), it is known to be dynamic and spatio-temporally regulated *in-vivo* as seen with the ligands (Andrae et al. 2008; Chen et al. 2013). Their expression has been detected in a large number of cell types (Heldin and Westermark 1999). The classical cells known to express PDGF, SMCs and fibroblasts, also express both alpha and beta receptors but in general higher levels of beta receptors are expressed. Some cells express only alpha receptor like the rat liver endothelial cells (Heldin et al. 1991), human platelets (Vassbotnlon et al. 1994), and O-2A glial precursor cells (Hart et al. 1989) while some others express only beta receptor like mouse capillary endothelial cells (Smits et al. 1989). In addition, PDGFR $\alpha$  is expressed in lens epithelium (Reneker and Overbeek 1996). Expression has also been seen in most mesenchyme cells with strong expression in subtypes of mesenchymal progenitors in skin, intestine, and lungs (Schatteman et al. 1992; Andrae et al. 2008).



Expression of PDGFR $\beta$  has been seen in mesenchyme, predominantly VSMCs and pericytes (Sorkin et al. 1993; Hellstrom et al. 1999; Andrae et al. 2008). PDGFR expression is generally low in mesenchymal cells *in-vivo*, however, expression is known to dramatically increase during inflammation and in culture and several factors have been reported to result in this expression induction, including TGF $\beta$ , FGF-2, estrogen, LPS, TNF $\alpha$  and IL-1 $\alpha$  (Heldin and Westermark 1999).

In the developing murine retina, expression of PDGFR $\alpha$  have been seen in astrocytes (Mudhar et al. 1993) with PDGFR $\beta$  in the microvascular pericytes (Benjamin et al. 1998). Meanwhile, in the adult retina, expression of PDGFR $\alpha$  have been seen in the ganglion cell layer with PDGFR $\beta$  at the Müller cell end feet at the internal limiting membrane (Cox et al. 2003).

### **2.3.3 Activation of the PDGFRs**

Although PDGFR activation independent of PDGF exist, which were first identified during pathological conditions, the best-known mechanism of PDGFR activation is the direct, PDGF-mediated form of activation (Kazlauskas 2017).

#### **2.3.3.1 Dimerization and auto-phosphorylation of Receptors**

The PDGF isoforms have two symmetric receptor binding epitopes each due to their dimeric nature. Hence, one molecule of PDGF simultaneously binds two receptor molecules bringing the two receptor promoters in nearness to each other (Duan et al. 1991; Fretto et al. 1993; Herren et al. 1993; Heldin and Westermark 1999; Chen et al. 2013). Hence, receptor dimer is formed which is non-covalently held together by the bivalent PDGF ligands (Betsholtz 2003; Heldin and Lennartsson 2013). Receptor dimerization and conformational changes results in destabilising the inhibitory interactions between the kinase and these three segments; the JM domain, the activation loop and the C-terminal tail (Rönnstrand 2010; Demoulin and Essaghir 2014). Receptor dimerization is therefore crucial in PDGFR activation as it puts side by side the receptor's intracellular parts allowing trans phosphorylation between the two receptors in the complex (Kelly et al. 1991; Heldin and Ostman 1996; Hoch and Soriano 2003; Chen et al. 2013; Kazlauskas 2017).

In principle, auto-phosphorylation has two important functions: firstly, auto-phosphorylation of tyrosines in the activation loop within the protein TK domain (i.e., Tyr849 in the PDGFR $\alpha$  and Tyr857 in the PDGFR $\beta$ ) (Fantl et al. 1989; Kazlauskas and Cooper 1989; Kazlauskas et al. 1991; Rönnstrand 2010) results in kinase activity

stimulation, and secondly auto-phosphorylation of tyrosines positioned outside the kinase domains (i.e., in the JM, kinase insert, and carboxyl-terminal regions) provides docking sites for cytoplasmic downstream signalling molecules (Kazlauskas and Cooper 1989; Heldin et al. 2002; Betsholtz 2003; Heldin and Lennartsson 2013; Demoulin and Essaghir 2014), largely those having the Src homology 2 (SH2) domain (Choudhury et al. 1998; Heldin and Westermark 1999; Tallquist and Kazlauskas 2004), but also those containing pleckstrin homology (PH) domains, recognising membrane phospholipids; SH3 domains recognising proline-rich regions; phosphotyrosine-binding (PTB) domains, recognising phosphorylated tyrosines; and Postsynaptic density protein (PSD95), Drosophila disc large tumor suppressor (DlgA), and Zonula occludens-1 protein (zo-1) (PDZ) domains, recognising C-terminal valine residue and specific upstream sequences (Pawson and Scott 1997; Pawson and Nash 2003). However, most PDGFR effectors bind via SH2 domains to distinct sites on the phosphorylated receptors (Ostman and Heldin 2007; Andrae et al. 2008).

So far, PDGFR- $\alpha$  and - $\beta$  have a total of 11 and 13 tyrosine phosphorylation sites respectively out of which 10 and 11 sites respectively have been identified as auto-phosphorylation sites (Heldin et al. 1998; Rönstrand 2010). In PDGFR $\beta$ , Y934 is not auto-phosphorylation site, but phosphorylated by Src family kinases (Hansen et al. 1996). Thus dimerized and activated PDGFRs associate with diverse families of SH2-domain containing molecules initiating activation of diverse signalling pathways and around 10 different families have so far been identified (Heldin et al. 2002; Ostman and Heldin 2007; Heldin and Lennartsson 2013). The SH2-domain containing molecules tend to bind specifically, binding specificities of which are determined by the three to six amino acid residues (different SH2-domains have preferences that differ for these amino acids) lying downstream of the phosphorylated tyrosine residues (Songyang et al. 1996; Heldin et al. 2002; Heldin and Lennartsson 2013). Some of the SH-2 domain signalling molecules have in-built enzymatic activity [e.g., tyrosine kinases Src, Fer and Fes; the tyrosine phosphatase, SHP-2; phospholipase C- $\gamma$  (PLC- $\gamma$ ); PI3-kinase; and the GTPase-activating protein (GAP) for Ras (RasGAP)] (Kim and Wong 1995; Heldin and Westermark 1999; Tallquist and Kazlauskas 2004; Ostman and Heldin 2007).

Thus, activation of the corresponding enzymatic activities occur either by receptor binding or by receptor kinases phosphorylation. On the other hand, the enzymes are constitutively active and are only carried by the activated receptors into the plasma

membrane inner leaflet (Heldin and Lennartsson 2013). Others (SH-2 domain signalling molecules) are adaptor molecules that are devoid of intrinsic enzymatic activity but rather are links between the receptors and other effectors downstream (Ostman and Heldin 2007; Shah et al. 2010). Examples of these adaptor molecules include; Growth Factor Receptor Bound Protein 2 and 7 (Grb2 and 7), GRB2 Associated Binding Protein 2 (Gab2), Crk, non-catalytic region of tyrosine kinase adaptor protein (Nck), Shc, and ALG-2-interacting protein X (Alix) (Yokote et al. 1996; Heldin et al. 1998). Grb2 complexes with the nucleotide exchange molecule, Sos1 (son of sevenless 1) (Grb2/Sos1 complex) and activates the small GTPase, Ras and the extracellular-signal-regulated kinases (ERK) MAPK pathway (Ostman and Heldin 2007; Andrae et al. 2008; Heldin and Lennartsson 2013). Nck and Crk activates JNK (Nishimura et al. 1993; Su et al. 1997). Alix binds around Tyr1021 region of the carboxyl-terminal tail and aids ubiquitin ligase (Cbl) binding (Lennartsson et al. 2006). PDGFRs, independent of auto-phosphorylation, also binds to signalling molecules or enhancers (e.g., the PDZ-domain protein, Na<sup>+</sup>/H<sup>+</sup> exchanger regulatory factors, NHERF), which binds to the carboxyl-terminal tail end of the receptors, facilitating receptor signalling (Maudsley et al. 2000; Demoulin et al. 2003; James et al. 2004; Takahashi et al. 2006; Theisen et al. 2007). They are also able to activate transcription factors of the STAT family (Darnell 1997; Heldin and Westermark 1999; Ostman and Heldin 2007). Additionally, not only do the PDGFRs bind to N-cadherin (Theisen et al. 2007) and the phosphatase, PTEN (phosphatase and tensin homologue) (Takahashi et al. 2006), they also associate with integrins (Assoian 1997; Frisch and Ruoslahti 1997). Interaction of PDGFRs with integrins aids the localisation of these receptors and associating molecules at focal adhesions, which are sites where numerous signalling pathways are initiated and are connected (Clark and Brugge 1995).

#### **2.4 PDGFR-induced signalling pathways**

Potentially, a signalling pathway is initiated with the binding of each signalling molecule to the receptors following ligand binding (Heldin et al. 2002). PDGFRs thereby induce a number of well-characterised signalling pathways, e.g., MAPK, phosphatidylinositol-3-kinase (PI3K), phospholipase C- $\gamma$  (PLC- $\gamma$ ), JAK/STAT pathways and others that mediate several cellular and developmental responses such as cell survival, migration, proliferation, and ECM production (Andrae et al. 2008; Ostendorf et al. 2012; Heldin and Lennartsson 2013; Borkham-Kamphorst and Weiskirchen 2016)

(Fig. 2.8). However, activation of the Ras-MAPK and the PI3K/Akt pathways are the two most characterised mechanisms through which cellular responses are being mediated by PDGFRs (Li et al. 2007).

#### **2.4.1 MAPK pathways**

MAP kinases pathways are important intracellular signalling pathways activated by PDGFs (Demoulin and Essaghir 2014; Eger 2016). MAP kinase family are proline (Pro)-targeted serine/threonine kinases (Turjanski et al. 2007; Roskoski 2012). They either undergo auto-phosphorylation i.e., phosphorylating their own dual serine and threonine residues or phosphorylate the ones located on their substrates, to either result in target activation or deactivation (Johnson and Lapadat 2002; Peti and Page 2013).

MAPKs are expressed ubiquitously and are highly conserved evolutionarily from plants, fungi, nematodes, insects to mammals (Widmann et al. 1999; Pimienta and Pascual 2007; Shaul and Seger 2007; Kyriakis and Avruch 2012; Peti and Page 2013). They participate in signal transduction from the cell surface to the cell interior and are responsive to enormous extracellular stimuli (Plotnikov et al. 2011; Roskoski 2012). They regulate numerous fundamental cellular processes whilst their dysregulation are also implicated in a number of diseased states (Dong et al. 2002; Wei and Liu 2002; Qi and Elion 2005; Liu et al. 2007; Pimienta and Pascual 2007; Raman et al. 2007; Shaul and Seger 2007; Turjanski et al. 2007; Arthur and Ley 2013). Induced cellular responses and implicated disease conditions are discussed under each of the individual pathways.

Each MAPK pathway is made up of a three-tiered kinase cascade consisting of MAP kinase kinase kinase (MAPKKK, MAP3K, MEKK or MKKK), which is often activated by a MAP4K lying upstream. Downstream, MAP3K phosphorylates and activates the MAP kinase kinase (MAPKK, MAP2K, MEK or MKK), which in turn, activates the MAPK by dual phosphorylation of conserved threonine (Thr) and tyrosine (Tyr) residues present in the activation loop (denoted as T-X-Y) (Songyang et al. 1996; Canagarajah et al. 1997; Chen et al. 2001; Pearson et al. 2001; Wei and Liu 2002; Cargnello and Roux 2011; Plotnikov et al. 2011; Morrison 2012; Roskoski 2012; Lee et al. 2016) (Fig. 2.10). Once activation of the MAPK occurs, diverse substrates gets phosphorylated (including transcription factors, phosphatases, and protein kinases) both in the cytosol and nucleus resulting in changes in gene expression and protein

function that execute the corresponding biological responses (Turjanski et al. 2007; Plotnikov et al. 2011; Morrison 2012; Roskoski 2012) (Fig. 2.10). For the phosphorylation of nuclear targets, active MAPKs often translocate to the nucleus from the cytoplasm (Qi and Elion 2005; Plotnikov et al. 2011). In mammalian cells, at least 14 MAP3Ks, 7 MAP2Ks, and 12 MAPKs have been recognised (Widmann et al. 1999). Dephosphorylation of MAPKs occur through the activity of dual specificity MAPK phosphatases (MKPs), serine/threonine phosphatases and tyrosine phosphatases that dephosphorylate both phospho-threonine and phospho-tyrosine residues on MAPKs (Sun et al. 1993; Keyse 2000; Liu et al. 2007; Pimienta and Pascual 2007; Zhang and Dong 2007).

The MAPKs have been grouped into three main families based on their structure, activation motif, and function and these are ERKs, ERK1 - ERK8; JNKs/SAPK (C-Jun amino (NH<sub>3</sub>)-terminal kinases/stress activated protein kinase - JNK1, JNK2 and JNK3); and p38/SAPKs - p38 $\alpha$ , p38 $\beta$ , p38 $\gamma$  and p38 $\delta$  (Schaeffer and Weber 1999; Chen et al. 2001; Kyriakis and Avruch 2001; Wei and Liu 2002; Cui et al. 2007; Zhang and Dong 2007; Cargnello and Roux 2011) (Fig. 2.10).

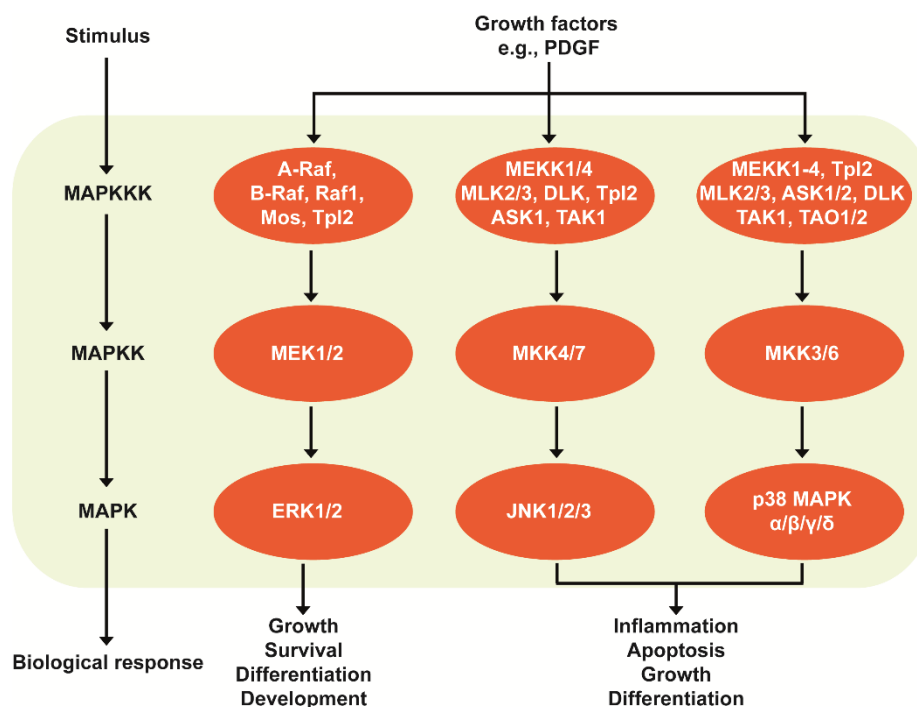

**Figure 2.10 Simplified MAPK signalling cascade.**

Image modified and adapted from Morrison, 2012. See text for details.

#### 2.4.1.1 ERK pathway

The MAPK/ERK pathway is also generally denoted as the Ras-Raf-MEK-ERK pathway. The ERKs have been the best studied amongst the MAPK pathways (Turjanski et al. 2007). They have a TEY motif in the activation segment and are generally grouped into two: the classical ERKs, that primarily have a kinase domain (ERK1 and ERK2) and the larger ERKs (e.g., ERK5), that have to their kinase domain, a relatively more extended carboxyl-terminal sequence (Zhang and Dong 2007). ERK1/2, also referred to as p44 and p42 MAPK, respectively, were the initial MAPKs to be identified in mammals (Rossomando et al. 1989; Nakielny et al. 1992), with 83-84% of sequence similarity, sharing almost all functions (Lloyd 2006; Turjanski et al. 2007). Hence, referred to as ERK1/2 (Roskoski 2012). However, ERK2 remains the best characterised member of this group (Turjanski et al. 2007).

Ras activation occurs in PDGF-stimulated cells and it is a key event in inducing signal transduction (Nånberg and Westermark 1993; Satoh et al. 1993; Heldin and Westermark 1999). PDGFRs interact with Ras-MAPK majorly through Grb2 and Shc adaptor proteins (Andrae et al. 2008). Grb2 is an adaptor molecule having one SH2 domain and two SH3 domains. The SH3 domains of Grb2 allows it to form a complex with Sos1 (Schlessinger 1993; Andrae et al. 2008) while its SH2 domain can either directly bind to auto-phosphorylated (activated) PDGFRs, or indirectly bind through other components, such as SHP-2 or Shc. Following the binding of these other components to PDGFRs, they get phosphorylated on tyrosine residues and are recognised by the SH2 domain of Grb2 (Heldin and Westermark 1999; Demoulin and Essaghir 2014). Grb2 complexes with Sos1, a guanine nucleotide exchange factor (GEF) for Ras, Sos1 subsequently activates Ras [(by converting membrane-bound Ras from its inactive, GDP-bound form (Ras-GDP) to its transductionally active, GTP-bound form - (RasGTP)] (Schlessinger 1993; Heldin and Westermark 1999; Andrae et al. 2008; Dance et al. 2008; Jurek et al. 2011). GTP hydrolysis, facilitated by guanine tri-phosphatase activator protein (GAP), thus terminates Ras signalling (Yoon and Seger 2006; Vigil et al. 2010).

Upon activation, Ras recruits Raf-1, a serine/threonine kinase, to the plasma membrane from the cytoplasm for subsequent activation which involves two key steps (Wellbrock et al. 2004; Jurek et al. 2011). First, the auto-inhibition imposed on the catalytic domain of Raf-1 by its regulatory domain is eased (Cutler et al. 1998). Second, the catalytic domain undergo multiple phosphorylation and de-

phosphorylation events which is necessary for elevation of Raf-1's basal activity (Chong and Guan 2003). Raf-1 is the first kinase (entry point) in the three-tiered MAPK cascade, and once activated, it initiates MAPK cascade activation by phosphorylation and activation of MEK1/2 which subsequently activates MAP kinases ERK1/2 by the phosphorylation of tyrosine and threonine residues in the TEY sequence in the catalytic domain (Heldin et al. 1998; Heldin and Westermark 1999; Thomas and Huganir 2004; Qi and Elion 2005; Jurek et al. 2011) (Fig. 2.10). This process is facilitated by KSR, a scaffold protein that links the three levels of kinases to Ras (Qi and Elion 2005). ERK1/2 thus have several known substrates in all the cellular compartments, including the cytoskeleton, membranes, cytoplasm, and nucleus (Yoon and Seger 2006). Some of these targets include but are not limited to transcription factors, such as NF- $\kappa$ B, AP-1, and Myc, kinases, such as ribosomal protein S6 kinases (RSKs), and the RSK-related mitogen and stress-activated kinases (MSKs) that are localised to the nucleus, the cell survival regulator, Bcl-2 (B-cell lymphoma-2), cPL2, and paxillin (cytoskeletal scaffold protein) (Thomas and Huganir 2004; Qi and Elion 2005; Turjanski et al. 2007).

This cascade is therefore involved in the regulation of numerous processes including cell migration, adhesion, survival, metabolism, proliferation or differentiation (depending on the stimulant strength and duration), cell cycle progression, transcription, learning and memory in nerve cells (Marshall 1995; Pearson et al. 2001; Qi and Elion 2005; McKay and Morrison 2007; Shaul and Seger 2007; Roskoski 2012).

#### **2.4.1.2 JNK Pathway**

Initially, a 54-kDa MBP kinase from cycloheximide-treated rat livers was purified as a form of JNK/SAPK (Kyriakis and Avruch 1990). Before long, purification by affinity adsorption to a c-Jun fusion protein gave rise to 46 and 54 kDa JNK/SAPKs (Hibi et al. 1993). Their characteristic feature is the dual phosphorylation motif Thr-Pro-Tyr (TPY) within their activation loop (Turjanski et al. 2007; Morrison 2012). Initially recognised as a mediator of the c-Jun transcription factor, JNK earned its other name, SAPK (stress-activated protein kinase) from being identified as an environmental, intra- or extra-cellular stress mediator (such as DNA damage, heat, genotoxic, ionising radiation, osmotic, hypoxic or oxidative stress) (Kyriakis and Avruch 1990; Davis 1994; Kyriakis et al. 1994; Qi and Elion 2005; Johnson and Nakamura 2007; Roskoski 2012).

However, it was later shown that similar to other MAPKs, this cascade is activated by several other stimuli that are stress independent like growth factors such as PDGF and cytokines such as TNF $\alpha$  and IL-1 $\beta$  (Davis 2000; Weston and Davis 2002; Qi and Elion 2005; Roy et al. 2008). Upon activation, signals get transmitted from the stimuli or stress factor to Rho family small GTPases such as Rac1 and CDC42, which then activates the MAP3Ks either directly or through MAP4Ks (Qi and Elion 2005; Plotnikov et al. 2011). Alternatively, association of the MAP3Ks and MAP4Ks with the adaptor protein, TRAF can also lead to their direct activation (Bradley and Pober 2001). With several MAP4Ks (Dan et al. 2001) and MAP3Ks (Craig et al. 2008) recognised, each of them can pass on the cascade's signal by binding to specific scaffold proteins under certain conditions [(e.g. JIPs (Whitmarsh 2006))] (Qi and Elion 2005). MAP3Ks for the JNK module include members of: the MEKK group, MEKK1 and MEKK4; the mixed lineage protein kinase group, MLK2 and MLK3; the apoptosis signal-regulating kinase group, ASK1; transforming growth factor- $\beta$  activated kinase -1 (TAK1), and tumour progression locus 2 (Tpl2) (Davis 2000; Qi and Elion 2005; Weston and Davis 2007; Morrison 2012). Following activation of MAP3Ks, their signals are further transmitted by Thr and Ser residue phosphorylation in the activation loop, in turn activating the MAP2Ks (MKK4 and MKK7) (Qi and Elion 2005; Wang et al. 2007; Weston and Davis 2007; Morrison 2012). Subsequently, the MAP2Ks activate the three MAPKs, JNK1/2/3, by directly phosphorylating the Tyr and Thr residues in the activation loop's Thr-Pro-Tyr motif (Weston and Davis 2007; Plotnikov et al. 2011) (Fig. 2.10).

The JNK gene isoforms, JNK 1, 2 and 3 are a result of differential splicing of a single gene whilst JNK1 and 2 are ubiquitously expressed in several tissues, expression of JNK3 is specific to brain, testis and heart (Qi and Elion 2005; Roy et al. 2008). Thus, each JNK is expressed as a short and long form, 46 and 54 kDa respectively (Cui et al. 2007). These forms however, seem to differ in their binding and phosphorylation ability to different substrate proteins (Roy et al. 2008). This cascade activation, results in the JNKs and perhaps their putative MAPKAPKs, to phosphorylate several targets (including transcription factors) present mainly in the nucleus, but also in the cytoplasm (non-nuclear proteins) (Barr and Bogoyevitch 2001; Cui et al. 2007; Plotnikov et al. 2011). Amongst their many substrates is c-Jun, to which JNK binds at the NH<sub>2</sub>-terminal activation domain and phosphorylates it on Ser63 and Ser73 residues (Wei and Liu 2002; Roy et al. 2008). In addition to c-Jun, the following transcription factors can also be phosphorylated by JNK: c-fos, activating transcription factor 2 and 3 (ATF2



and 3), JunB, and JunD. Together with c-Jun, these transcription factors collectively make up the AP-1 transcription factor which is involved in regulating expression of numerous stress-responsive genes (Roy et al. 2008). Additionally, JNK phosphorylates DPC4, tumour protein p53 (TP53), nuclear factor of activated T-cells 4 (NFAT4), c-Myc, SRF (Serum Response Factor) accessory protein 1a (Sap-1a), ETS Like-1 protein (Elk-1), Jun Dimerization Protein 2 (JDP2), and the Ets-related transcription factor, PEA3 (O'Hagan et al. 1996; Ip and Davis 1998; Widmann et al. 1999; Bogoyevitch and Kobe 2006). MST1 (Bi et al. 2010) and MAPKAPK3 (Ludwig et al. 1996) have also been shown to be phosphorylated by JNKs, however, their functional properties as classical MAPKAPKs remains a subject of debate (Plotnikov et al. 2011).

These phosphorylated substrates subsequently control the transcription of numerous genes which in turn mediate cellular processes such as immune responses, insulin signalling, neuronal activity, survival signalling, apoptosis, metabolism, cytokine production (Wei and Liu 2002; Dhanasekaran and Reddy 2008; Haeusgen et al. 2009; Huang et al. 2009; Rincón and Davis 2009) and several others (Whitmarsh 2007). Thus any dysregulation of this cascade can lead to numerous diseases. JNKs have been implicated in a number of neurodegenerative diseases, including but not limited to ALS, PD, AD (Kim and Choi 2010), inflammation (Zhang and Kaufman 2008), diabetes (Tanti and Jager 2009), and many types of cancers (Wagner and Nebreda 2009).

#### **2.4.1.3 p38 MAPK pathway**

The discovery of p38 $\alpha$  was borne out of three independent context. First, isolated as a 38-kDa tyrosine phosphoprotein present in LPS-treated cell extracts (Han et al. 1993, 1994). Second, as a pyridinyl imidazole binding drug that blocked the biosynthesis of inflammatory cytokines like IL-1 and TNF $\alpha$  in LPS stimulated monocytes, as such, it was referred to as cytokine-suppressive anti-inflammatory drug-binding protein (CSBP) (Lee et al. 1994) and third, as MAPK activated protein kinase-2 (MAPKAP-2) reactivating kinase (Rouse et al. 1994). Furthermore, the other three splice variants [p38 $\beta$  (p38-2), p38 $\gamma$  (ERK6 or SAPK3), and p38 $\delta$  (SAPK4)] encoding members of the p38 subfamily were identified by cloning strategies instead of biological approaches (Jiang et al. 1996; Lechner et al. 1996; Li et al. 1996; Goedert et al. 1997; Jiang et al. 1997; Kumar et al. 1997; Stein et al. 1997). Amongst the four

isoforms, p38 $\alpha$  and p38 $\beta$  are ubiquitously expressed while p38 $\gamma$  and p38 $\delta$  are expressed differentially depending on the type of tissue (Zarubin and Han 2005).

A Thr-Gly-Tyr (TGY) dual phosphorylation motif in the activation loop is characteristic of all p38 kinases (Hanks and Hunter 1995; Plotnikov et al. 2011; Morrison 2012) while comparison of the sequences showed that each of the isoforms share approximately 60% identity within the group but only 40-45% with other three members of the MAPK family (Zarubin and Han 2005). The p38 MAPKs respond to and are activated by several chemical and physical stresses including but not limited to ischemia, UV irradiation, hormones, heat and osmotic shock, certain mitogens like PDGF, protein synthesis inhibitors, LPS, inflammatory cytokines like TNF $\alpha$  and IL-1 (Wei and Liu 2002; Qi and Elion 2005; Zarubin and Han 2005).

Upon receptor activation or stress induction, signals get transmitted to the p38 cascade via small GTPases, adaptor proteins, MAP4Ks and MAP3Ks identical to the ones that are involved in the JNK cascade (Plotnikov et al. 2011). However, the differences in activation between the p38 and JNK cascades are facilitated by specific scaffold proteins, compartmentalisation, and variable substrates (Morrison and Davis 2003; Cuevas et al. 2007; Raman et al. 2007). Upon transmission of signals by MAP3K component cascade level, these signals result in the induction of phosphorylation and activation of the p38 cascade MAP2K components, mainly MKK3 and MKK6 (SKK3) (Qi and Elion 2005; Rubinfeld and Seger 2005; Zarubin and Han 2005; Raman et al. 2007; Morrison 2012), but can also include MKK4 for p38- $\alpha$  and - $\gamma$  (Whitmarsh and Davis 2007) under certain conditions. Several MAP3Ks are involved in the p38 cascade, including MEKK1-MEKK4, DLK (MUK/ZPK), ASK1 (MAPKKK5), MLK2 and 3, TAK1, TAO1/TAO2 and Tpl2 (Qi and Elion 2005; Zarubin and Han 2005; Raman et al. 2007; Morrison 2012). Following the transmission of signals to the MAP2Ks, these signals are further passed on to the four p38 isoforms (Fig. 2.10) and a few functional differentially spliced forms at the MAPK cascade level (32-54 kDa) (Plotnikov et al. 2011). Alternatively, p38 activation can also be facilitated by auto-phosphorylation independent of MAP2K where activation can be induced either by phosphorylation of Tyr323 by ZAP-70 (Salvador et al. 2005), by association with analogues of lipidic phosphatidyl inositol (Gills et al. 2007), or by stimulated interaction with TAB1 (TAK1-binding protein) adaptor proteins (Ge et al. 2002), subsequently catalysing an enhanced auto-phosphorylation of p38s on its activatory residues (Plotnikov et al. 2011). Activation of the p38 MAPKs thus leads to activation of numerous substrates

amongst which are transcription factors, protein kinases and other types of substrates (Zarubin and Han 2005; Morrison 2012).

Protein kinase substrates of p38 include: the MAPK-activated protein kinase 2 (MAPKAPK2 or MK2) (Zarubin and Han 2005), its closely associated family member, MK3 (3pk) both of which activate numerous targets including cAMP response element-binding protein (CREB), lymphocyte-specific protein 1 (LSP1), small heat shock protein 27 (HSP27), tyrosine hydroxylase (Zarubin and Han 2005). Other protein substrates are; MAPKAPK-5, MNK1, MNK2 (Fukunaga and Hunter 1997; Waskiewicz et al. 1997; Wei and Liu 2002; Plotnikov et al. 2011).

Transcription factors substrate of P38 include; Sap-1a, high mobility group-box protein 1 (HBP1), ATF-1/2/6, NFAT, p53, microphthalmia-associated transcription factor 1 (MITF1), myocyte enhancer factor 2C and 2A (MEF2C and 2A), ELK1, C/EBP $\beta$ , DNA damage-inducible transcript 3 protein (DDIT3), NF- $\kappa$ B, and AP-1 (Wei and Liu 2002; Qi and Elion 2005; Zarubin and Han 2005). Other p38 substrates include; keratin 8, tau, Na<sup>+</sup>/H<sup>+</sup> exchanger isoform-1 (NHE-1), cPLA2, and stathmin (p38 $\delta$ ) (Young et al. 1993; Reynolds et al. 1997; Kusahara et al. 1998; Parker et al. 1998; Feng et al. 1999). Dephosphorylation of the p38 MAPK cascade is triggered by many dual-specificity protein phosphatases while p38 $\alpha$  and p38 $\beta$  can be dephosphorylated by several members of these proteins (Muda et al. 1996; Camps et al. 1998), p38 $\gamma$  and p38 $\delta$  seem to resist all the identified MKP family members (Zarubin and Han 2005). However, MPK5/7 which dephosphorylates JNK also does same for p38, MPK2/4, which deactivates ERK also dephosphorylates p38 while MPK1 as a higher specificity for p38 (Owens and Keyse 2007; Salojin and Oravec 2007).

Activation of p38 MAPK therefore play significant roles in gene expression regulation, survival, proliferation, differentiation, development, stress responses, inflammation, senescence, apoptosis, and cell cycle regulation (Wei and Liu 2002; Zarubin and Han 2005; Cuenda and Rousseau 2007; Maruyama et al. 2009; Cuadrado and Nebreda 2010; Plotnikov et al. 2011; Roskoski 2012). Gene targeting experiments have also shown that p38 is indispensable for erythropoietin production and angiogenesis (Qi and Elion 2005; Roskoski 2012). Thus, the involvement of this cascade in all these essential processes implies that any cascade dysregulation would therefore have pathological consequences (Plotnikov et al. 2011) as seen in diabetes (Liu and Cao 2009), in the induction and sustenance of neurodegenerative diseases (Kim and Choi

2010), in cancer (Loesch and Chen 2008), in cardiovascular diseases (Coulthard et al. 2009), and in asthma (Qi and Elion 2005).

#### 2.4.2 Phosphatidylinositol-3-kinase (PI3K) pathway

The PI3K family is a large and complex family of intracellular lipid kinases that phosphorylate phosphatidylinositol and phosphoinositides in their 3' position (i.e., phosphorylating the 3-OH group) (Engelman et al. 2006; Vanhaesebroeck et al. 2012) (Fig. 2.11).

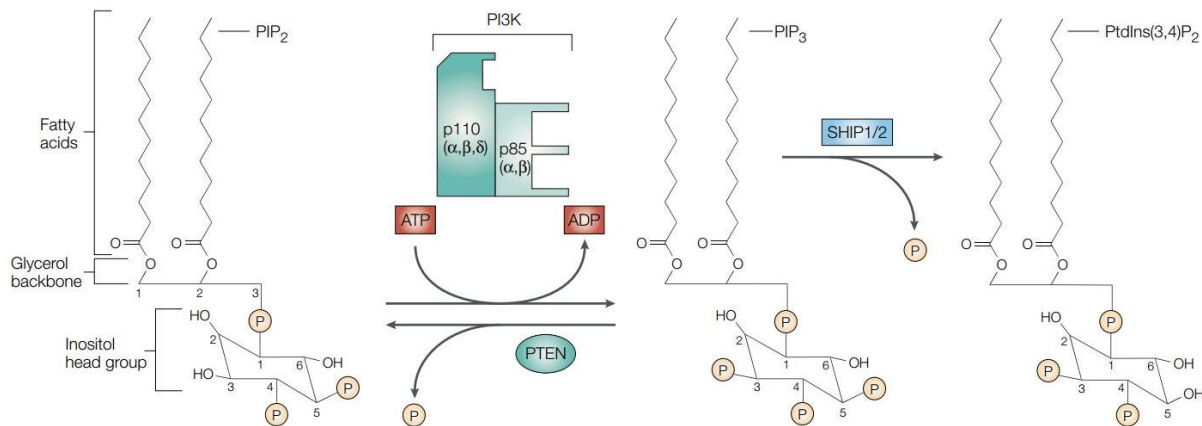

**Figure 2.11 Enzymatic activity of PI3K and SHP1/2 with their corresponding substrate.**

Phosphatidylinositol phosphates (PIPs) are made of membrane bound fatty acids and a glycerol backbone linked to a cytosolic, phosphorylated, inositol head group. PIP<sub>2</sub> is phosphorylated at the 3' position by PI3K forming PIP<sub>3</sub>. The phosphatase, PTEN, can dephosphorylate PIP<sub>3</sub> back to regenerate PIP<sub>2</sub>. In addition, SHP1/2 can dephosphorylate PIP<sub>3</sub> at the 5' position generating PtdIns(3,4)P<sub>2</sub>, another potential second messenger (Vivanco and Sawyers 2002).

They are highly conserved evolutionarily amongst multicellular organisms (Engelman et al. 2006; Hemmings and Restuccia 2012; Fruman et al. 2017). Molecular cloning of the PI3Ks revealed that there are three members (Class I - III) in this family with multiple subunits and isoforms (Vivanco and Sawyers 2002), classified according to their substrate specificity, structural characteristics, lipid products, and sequence homology (Fruman et al. 1998; Katso et al. 2001; Cantley 2002).

Class I PI3K is further subdivided into IA and IB on the basis of structural and functional differences (B Vanhaesebroeck et al. 1997). Class IA is activated by G protein-coupled receptors (GPCRs), RTKs like PDGFRs, and certain oncogenes like the small G protein RAS while Class IB are exclusively activated by GPCRs (Vivanco and Sawyers 2002; Carracedo and Pandolfi 2008; Liu et al. 2009). The regulatory subunits of both sub-classes differ; p85α/p85β/p55γ (collectively referred to as p85) and

p101/p84/p87PIKAP for class IA and IB respectively (Bader et al. 2005; Engelman et al. 2006; Carracedo and Pandolfi 2008). Class I is characterised for generating predominantly the second messenger, phosphatidylinositol-3,4,5-trisphosphate [PI(3,4,5)P<sub>3</sub>], by phosphorylating phosphatidylinositol-4,5-bisphosphate [PI(4,5)P<sub>2</sub>], the main *in-vivo* substrate (Katso et al. 2001; Vivanco and Sawyers 2002; Liu et al. 2009). Class II PI3K which have three sub-classes, PI3KC2 $\alpha$ , PI3KC2 $\beta$ , and PI3KC2 $\gamma$ , generates PI-3,4-P<sub>2</sub> from PI-3P as well as PI-3-P from PI and can be activated by cytokine receptors, RTKs, and integrins while Class III PI3K have only one single member, homologue of the yeast vacuolar protein sorting-associated protein 34 (hVPS34) also referred to as PIK3C3 (Carracedo and Pandolfi 2008; Liu et al. 2009; Fruman et al. 2017).

Of the three classes of enzymes, class I, activated by cell surface receptors, have been the most studied (Carracedo and Pandolfi 2008; Liu et al. 2009) and this review focuses on this class of PI3K enzymes. Members of this PI3K family (Class IA PI3Ks) are heterodimers that have a catalytic subunit, p110 [encoded by three genes ( $\alpha$ ,  $\beta$  and  $\delta$ ), which all have similar basic structure] and a regulatory subunit, p85 [also encoded by one of three genes ( $\alpha$ ,  $\beta$  and  $\gamma$  which all undergo differential splicing) (Vivanco and Sawyers 2002; Liu et al. 2009). The regulatory subunit, p85, codes for an adaptor-like protein containing two SH2 domains (binding to the motif pYXXM, where pY denotes a phosphorylated tyrosine residue) (Zhou et al. 1993; Vivanco and Sawyers 2002) and an inter-SH2 domain binding constitutively to the catalytic subunit, p110 (Vivanco and Sawyers 2002). This p85 regulatory subunit, facilitates binding and activation of the receptor as well as enzyme localisation (Liu et al. 2009). It also directly binds to two auto-phosphorylated tyrosine residues, conserved in both PDGFRs (Tyr740 and Tyr751 in PDGFR $\beta$ , both having a methionine at the +3 position) (Yu et al. 1991; Fantl et al. 1992; Kashishian et al. 1992; Kazlauskas et al. 1992; Cantley 2002; Demoulin and Essaghir 2014). This binding therefore activates PI3K. The generation of this complex thus results in the membrane translocation and increased enzymatic activity of the p110 catalytic subunit, generating the product, PIP<sub>3</sub> (Backer et al. 1992; Demoulin and Essaghir 2014). Kavanaugh et al., 1994, also showed that in addition to the aforementioned tyrosine phosphorylation sites, p85 regulatory subunit can also be phosphorylated at Tyr508 following binding to PDGFR $\beta$ .

PI3K can also be activated by RTKs via Ras association and the resulting binding of GTPase to the Ras-binding domain (RBD) of PI3K (Engelman et al. 2006). By an

extensively studied mechanism which has been reviewed by Hanada et al., 2004, the lipid second messenger (PIP3) generation thus results in the activation of a cascade of effector kinases that starts with PDK1 (phosphoinositide-dependent kinase-1) activation which phosphorylates the serine/threonine kinase, Akt (protein kinase B, PKB) (Burgering and Coffey 1995; Franke et al. 1995; Klippel et al. 1997) (Fig. 2.12), the atypical protein kinase C isoforms ( $\delta$ ,  $\epsilon$ , and  $\zeta$ ) (Nakanishi et al. 1993; Toker et al. 1994; Akimoto et al. 1996; Moriya et al. 1996), and the p70 S6 kinase (Chung et al. 1994; Cheatham et al. 1994). All these kinases thus contribute to PDGFR signalling (Heldin et al. 1998).

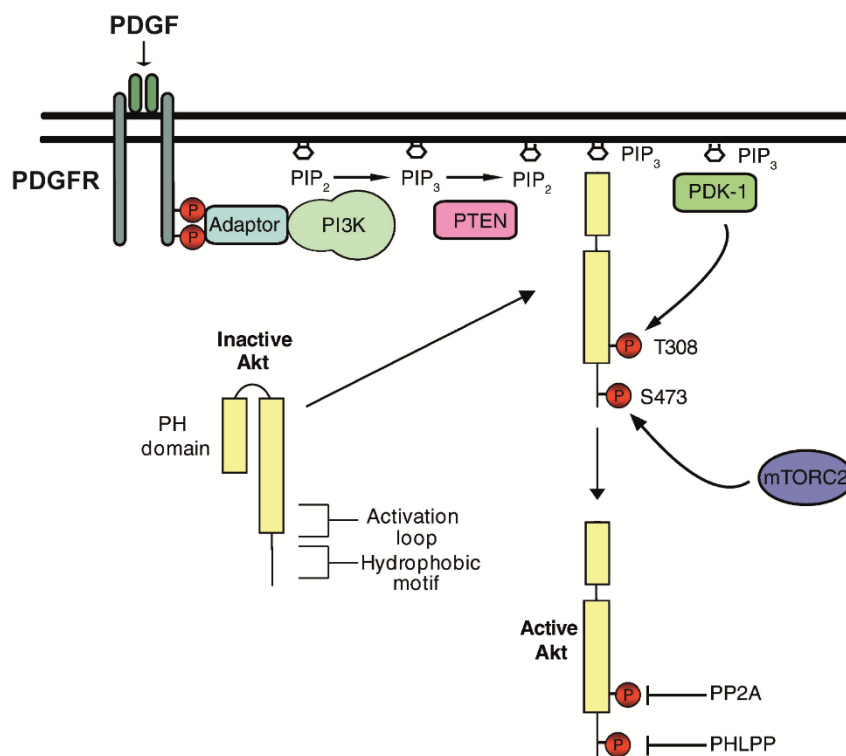

**Figure 2.12 Activation and regulation of Akt.**

Image modified and adapted from Hers et al., 2011. See text for details.

Other effectors of PI3K include small GTPases of the Rho family (Hawkins et al. 1995), JNK (Lopez-Illasaca et al. 1997), and the serine/threonine kinase, mammalian target of rapamycin (mTOR), that forms two cellular complexes, mTORC1 and mTORC2, having distinct subunit composition and substrate selectivity (Saxton and Sabatini 2017). In comparison to other effectors, the Akt member family are more commonly activated downstream of receptor-induced PI3K activation and phosphorylation of Akt is often the prototype readout of PI3K class I activation (Fruman et al. 2017). As such,

the PI3K/Akt pathway is regarded as the prototype PI3K signalling (Carracedo and Pandolfi 2008).

Akt, expressed as three isoforms, Akt1, Akt2 and Akt3, are encoded by PKB $\alpha$ , PKB $\beta$  and PKB $\gamma$  genes respectively (Scheid and Woodgett 2001; Vivanco and Sawyers 2002). Expression of these three isoforms are broad while sharing the same structure consisting of an amino-terminal PH domain, a central serine/threonine catalytic domain, and a short carboxyl-terminal regulatory domain (Vivanco and Sawyers 2002; Liu et al. 2009). Activation of Akt thereby begins with its translocation to the plasma membrane, facilitated by docking of the PH domain (in the N-terminal region of Akt) to PIP3 (which has been generated on the plasma membrane's inner leaflet in response to PI3K activation) on the membrane (Andjelković et al. 1997; Bellacosa et al. 1998; Liu et al. 2009). Subsequent conformational changes in Akt thus exposes two indispensable amino acid residues (Thr308 and Ser473) for phosphorylation (Alessi, Deak, et al. 1997; Heldin et al. 1998; Stephens et al. 1998). Full activation of Akt therefore requires phosphorylation of both Thr308 (in the activation loop by PDK1) and Ser473 (in the carboxyl-terminal hydrophobic motif by putative PDK2) (Fig. 2.12) (Alessi, James, et al. 1997; Stokoe et al. 1997; Stephens et al. 1998; Vanhaesebroeck and Alessi 2000). Several potential PDK2s have been recognised, including PKC $\beta$ 2, ILK (integrin-linked kinase), ATm (ataxia telangiectasia mutated), DNA-dependent protein kinase (DNA-PK) and Akt itself (Scheid and Woodgett 2001; Feng et al. 2004); however, the source of PDK2 in most situation still remains the mTOR–riCTOR (rapamycin insensitive companion of mTOR) complex (mTORC2) (Sarbasov et al. 2005). So once phosphorylation and activation of Akt occurs, it phosphorylates up to about 100 substrates, thus regulating various cellular functions (Hanada et al. 2004; Carracedo and Pandolfi 2008).

First, by phosphorylating and inhibiting important pro-apoptotic proteins, such as caspase 9, mouse double minute 2 (MDM2), Bcl-2 associated agonist of cell death (BAD), and FOXOs (the forkhead box family of TFs which plays a vital role in PDGFR signalling), Akt is able to wield a strong anti-apoptotic effect, (Hanada et al. 2004; Carracedo and Pandolfi 2008). It is also able to regulate cell cycle and survival (through p21 and MDM2), and regulate metabolism (Hanada et al. 2004; Engelman et al. 2006). However, PDGF-mediated anti-apoptotic effect was shown by Romashkova and Makarov, 1999 to be reliant on Akt induced NF- $\kappa$ B activation [which binds and activates the I $\kappa$ B kinase (IKK)] but this finding was disputed by Rauch et al., 2000 and

Peppel et al., 2005 where they showed that PDGF-mediated NF- $\kappa$ B activation is insignificant in comparison to actual NF- $\kappa$ B stimuli such as TNF $\alpha$ .

Second, Akt is able to activate proliferation of cells by p27 inactivation (Fujita et al. 2002) and inhibition of glycogen synthase kinase 3 (GSK3)-mediated Myc and cyclin D1 inhibition (Scheid and Woodgett 2001; Vivanco and Sawyers 2002; Manning and Cantley 2007). In addition, activated PI3K pathway can also regulate the following effects in response to PDGF; differentiation, polarity and motility, transcription, protein synthesis, vesicle trafficking, glucose homeostasis, promotion of actin reorganisation (Hu et al. 1995; Bart Vanhaesebroeck et al. 1997; Vivanco and Sawyers 2002; Bader et al. 2005; Engelman et al. 2006; Manning and Cantley 2007; Hemmings and Restuccia 2012).

Numerous proteins have been recognised as negative regulators of PI3K activation intensity but the main regulator being, phosphatase PTEN (also referred to as MMAC1), that tightly regulates cellular level of PIP3 (Cantley and Neel 1999; Cully et al. 2006; Carracedo and Pandolfi 2008). Initially, the PTEN homologue deleted on chromosome TEN was identified as a candidate tumor suppressor mutated and lost in various cancers (Li and Sun 1997; Steck et al. 1997) until it was characterised as a lipid phosphatase that hydrolyses the phosphate group (transferred by PI3K) in the 3' position of phosphoinositides making it in control of PI3K signal termination (Maehama and Dixon 1998; Stambolic et al. 1998; Wu et al. 1998; Carracedo and Pandolfi 2008) (Fig. 2.12). NHERF (EBP50) and NHERF-2 adaptor proteins recruit PTEN to the PDGFR complexes (Takahashi et al. 2006) while binding via two PDZ domains to the C-terminus of the receptor (Maudsley et al. 2000), disrupting this complex thus induces PI3K signalling (Demoulin et al. 2003; Takahashi et al. 2006). Functionally, PTEN is able to antagonise PI3K's activity via its built-in lipid phosphatase activity by reducing the cellular level of PIP3 via the conversion of PIP3 back to PIP2 (Vivanco and Sawyers 2002; Liu et al. 2009) (Fig. 2.12). PTEN levels are transcriptionally regulated by PI3K (Carracedo and Pandolfi 2008) as such any PTEN loss results in dysregulated PI3K signalling pathway, which can lead to cancer (Cully et al. 2006).

Downstream of PI3K, Akt activation can also be negatively regulated by different identified proteins. While Thr308 is primarily dephosphorylated by protein phosphatase 2A (PP2A), Ser473 is dephosphorylated by PH domain leucine-rich repeat protein phosphatase (PHLPP1/2) (Fig. 2.12) (Andjelković et al. 1996; Bayascas and Alessi 2005; Gao et al. 2005; Brognard et al. 2007). Additionally, Tribbles



homologue 3, a pseudo-kinase, binds and inhibits Akt, causing insulin resistance (Du et al. 2003), while the carboxyl-terminal modulator protein, (CTMP) specifically binds to the carboxyl-terminal regulatory domain of PKB $\alpha$  at the plasma membrane, thus reducing the activity of PKB $\alpha$  by inhibiting Thr308 and Ser473 phosphorylation (Maira et al. 2001). As a result of the vital role of Akt in an array of fundamental cellular processes, dysregulation of its kinase, inevitably would be associated with numerous diseases including cancer and cancer susceptibility syndromes, insulin and non-insulin dependent diabetes, neurological and cardiovascular diseases (Carracedo and Pandolfi 2008; Hers et al. 2011).

## **2.5 Crosstalk between the signalling pathways**

In response to PDGF stimulation, a number of signalling pathways are initiated, some of which have been discussed. These signalling pathways are however not linear as extensive cross-talk occur between them (Eger 2016). For example, PI3K associates with Ras, forms a complex to mutually activate each other (Rodriguez-Viciano et al. 1994; Hu et al. 1995; Klinghoffer et al. 1996). Additionally, Ras mediates some particular PI3K responses (Sato et al. 1993; Hu et al. 1995). Besides, Ras also activates the small GTP binding proteins, Rac, Rho, and Cdc42 (Khosravi-Far et al. 1995; Olson et al. 1995; Qiu et al. 1995, 1997). As a result, a given signal transduction pathway can display different degrees of importance for a particular response depending on the different signal transduction molecules present in different cells (Heldin et al. 1998).

## **2.6 Modulation and regulation of PDGFR signalling**

Growth factor signalling, inevitably must be tightly regulated, as a result, PDGFR signalling is thoroughly regulated by feedback control mechanisms (Heldin et al. 1998; Andrae et al. 2008; Rönstrand 2010; Borkham-Kamphorst and Weiskirchen 2016). One example is Ras-GAP, that negatively regulates Ras, also binds through its SH2 domain to PDGFR $\beta$  (Fantl et al. 1992). Another example is deployed through cAMP synthesis induction. PDGF-stimulation results in an increase in intracellular levels of cAMP (Heldin et al. 1998), through a mechanism that involves phospholipase A2 activation mediated by MAPK; ultimately, this results in arachidonic acid release, prostaglandin E2 synthesis by cyclo-oxygenase and subsequently adenylyl cyclase activation (Graves et al. 1996). The expression of cox enzyme in SMCs is thus a determining factor for which direction MAPK pathway activation goes, either leading

to stimulation or inhibition of proliferation (Bornfeldt et al. 1997). cAMP-dependent protein kinase activation thus inhibits growth in various cells by inhibiting a number of pathways including; the eukaryotic initiation factor 4E (Graves et al. 1995); the MAPK (via Raf-1 inhibition or MAPK phosphatase-1 induction) (Heldin et al. 1998); cyclin expression and cyclin-dependent kinases (Gagelin et al. 1994; Kato et al. 1994); and the p70 S6 kinase (Graves et al. 1995; Monfar et al. 1995).

Another remarkable feature in PDGFR signalling is the simultaneous occurrence of stimulatory and inhibitory signals, utmost response of which is dependent on the balance between these signals (Heldin et al. 1998; Borkham-Kamphorst and Weiskirchen 2016). An example is the simultaneous binding to activated PDGFRs of the Grb2/SOS1 complex (that activates Ras) and of RasGAP (that inactivates Ras) (Heldin et al. 1998; Heldin and Lennartsson 2013).

### **2.6.1 Cbl mediated ubiquitination and degradation**

A major pathway for RTK protein expression regulation is via receptor ubiquitination, which targets them for degradation. Thus, ubiquitin E3 ligase, Cbl, is one of the most important ubiquitination regulator of the PDGFRs (Bonita et al. 1997; Miyake et al. 1999). Upon PDGFR activation, diverse mechanisms recruit Cbl to the receptor and induces ubiquitination of the receptor which activates endocytosis (Joazeiro et al. 1999; Lennartsson et al. 2006). Cbl thus interacts with RTKs either directly through the binding of its tyrosine kinase binding (TKB) domain to the receptor or indirectly via Grb2 adaptor protein. However, the direct binding via its TKB domain is the major path (Bonita et al. 1997) where it associates with activated PDGFR $\beta$  by binding to Tyr1021 in the carboxyl-terminus of the receptor (Reddi et al. 2007).

Cbl recruitment therefore results in its phosphorylation via Src family kinases and ubiquitination of lysine residues on target proteins, this ultimately labels the proteins for lysosomal degradation through the endosomal sorting complex (Haglund et al. 2003). The tyrosine binding site for Cbl is also the docking site for PLC $\gamma$ -1, which leads to competitive binding, as a result, cells lacking Cbl show increased PLC $\gamma$ -1 activation and increased PDGF-induced chemotaxis (Rönstrand 2010). Additionally, PDGFR $\beta$  mutants with reduced ability for ubiquitination were seen to have a longer half-life, a result of slower degradation (Mori et al. 1992). Cbl degradation is facilitated by the adaptor protein, Alix, which binds to the C-terminal domain of PDGFR $\beta$ , thus preventing receptor ubiquitination and stabilising it (Lennartsson et al. 2006).

### **2.6.2 Dephosphorylation of the PDGFR**

Given that tyrosine phosphorylation mediates essential diverse physiological responses, it must therefore be thoroughly controlled. Protein tyrosine phosphatases (PTPs) are key players that mediate this regulation. Most PTPs negatively regulate by dephosphorylating receptors and downstream targets, thus leading to signal termination. PTP's are known to exhibit a certain level of specificity by recognising specific target sequences that vary between PTPs (Rönstrand 2010). A number of PTP's have thus been shown to be related to PDGFR signalling and these include; low-molecular weight PTP (LMW-PTP), PTEN, PTP1B, T-cell PTP, transmembrane tyrosine phosphatase CD45, density-enhanced phosphatase-1 (DEP-1, also called rPTP-h or CD148) and SHP-2 (also called PTP1D or Syp) (Mooney et al. 1992; Way and Mooney 1993; Kang 2007).

SHP-2, via its SH2 domain, binds to PDGFR $\beta$ , dephosphorylates it and its substrates (Lechleider et al. 1993; Heldin et al. 1998). T-cell PTP is expressed ubiquitously, regardless of its name (Rönstrand 2010) and Y1021 in the PDGFR $\beta$  (docking site for PLC $\gamma$ -1) was recognised as its target using phospho-specific antibodies directed against individual sites in the PDGFR $\beta$  and mouse embryonal fibroblasts carrying a targeted deletion of T-cell PTP (Persson et al. 2004; Heldin and Lennartsson 2013). As expected, cells deficient in T-cell PTP, showed an increase in PLC $\gamma$ -1 phosphorylation (Rönstrand 2010). Overexpression of the LMW-PTP was also shown to inhibit phosphorylation of PDGFR and mitogenic stimulation (Berti et al. 1994) while a mutated, catalytically inactive phosphatase complexes with activated PDGFR (Chiarugi et al. 1995). PTEN was shown to dephosphorylate activated PDGFR with a resultant decrease in PDGF-induced DNA-synthesis (Mahimainathan and Choudhury 2004).

### **2.6.3 Receptor signalling regulation by serine/threonine phosphorylation**

Asides tyrosine dephosphorylation on RTKs and their respective degradation, serine/threonine phosphorylation is however another mechanism by which a number of RTKs have been controlled (Rönstrand 2010). PDGF-BB-induced PDGFR $\beta$  phosphorylation was studied and a sharp increase in serine phosphorylation was seen where this effect was blocked by casein kinase 1 inhibitor (CKI is a serine/threonine kinase) (Bioukar et al. 1999; Rönstrand 2010). Another serine/threonine kinase known to regulate the kinase activity of PDGFRs is G-protein-coupled receptor kinase-

2 (GRK2). PDGFR $\beta$  is phosphorylated at Ser1104 in the carboxyl-terminal end of the protein by GRK2 thus interfering with the binding of NHERF (Hildreth et al. 2004). Owing to NHERF's ability to mediate PDGF-induced receptor dimerization, binding of GRK2 thus results in a decrease in PDGFR $\beta$  activation and downstream targets like Akt (Rönnstrand 2010). A-Raf is also another member belonging to the same family as the serine/threonine kinase, Raf-1. A-Raf occurs in a preformed complex with PDGFR $\beta$ , regulating the receptor's activity (Mahon et al. 2005). Expression of a partially active mutant of A-Raf was shown to result in reduced PDGFR $\beta$  phosphorylation selectively at Y1021 and Y857, the site of interaction with PLC $\gamma$ -1 and the activation loop site respectively (Rönnstrand 2010).

#### **2.6.4 Spatiotemporal cellular regulation of PDGFRs**

The synthesis of PDGFRs occur in the the endoplasmic reticulum from where they become heavily N- and O-glycosylated in the Golgi (Demoulin and Essaghir 2014). Following synthesis, they are not evenly distributed throughout the cell membrane, but rather have been found to be concentrated in different cell membrane structures such as lipid rafts, clathrin-coated pits, and caveolae (clear-cut membrane invaginations involved in endocytosis) (Liu et al. 1996; Demoulin and Essaghir 2014).

Using image correlation spectroscopy, Wiseman et al., 1997, could also confirm the clustering of PDGFRs in the absence of ligand. Upon ligand binding, the ligand-receptor complex become internalised in the endosomes in a manner dependent on a clathrin and dynamin through a process that also partially depends on the receptor's kinase activity - of particular importance for this activity is auto-phosphorylation of Tyr579 in the JM (Sorkin et al. 1991; Mori et al. 1994), in addition to the receptor-PI3K interaction (Joly et al. 1994). Signalling is continued in early endosomes (Wang et al. 2004; Kawada et al. 2009; Muratoglu et al. 2010), until the ligand dissociates from the receptor (caused by a decrease in pH) (Heldin and Westermark 1999; Heldin and Lennartsson 2013) and the receptor is recycled back to the cell membrane in a PKC-dependent manner (Heldin and Westermark 1999; Hellberg et al. 2009), or in the alternate, the ligand-receptor complex is degraded (Heldin and Westermark 1999). Though the recycling of PDGFR $\beta$ , but not PDGFR $\alpha$ , have been seen in TC-PTP (negatively regulates PDGFR $\beta$  phosphorylation) deficient cells (Persson et al. 2004; Karlsson et al. 2006), the latter pathway (of degradation), however seems to be predominant in the studied cell types (Heldin and Westermark 1999). Most of the

internalised PDGFRs undergo degradation by fusion of endosomes with multi-vesicular bodies and lysosomes (lysosomal degradation) (Heldin et al. 1982; Sorkin et al. 1991; Mori et al. 1995; Heldin and Westermark 1999), or are cytoplasmically degraded in proteasomes, processes that are facilitated by poly-ubiquitination of the receptors (Heldin et al. 1982; Mori et al. 1992, 1995).

Thus, activated receptors induced by ligand binding will be deactivated by degradation within half an hour to one hour after internalisation (Sorkin et al. 1993). Specifically, in this activated state, PDGFR $\alpha$  have been reported to have an half-life of approximately 5 minutes (Rosenkranz et al. 2000) where the half-life of PDGFR $\beta$  is said to be seemingly 6 times longer (around 30 minutes) while in resting cells, half-lives range from approximately 2 hours for PDGFR $\beta$  to around 3 hours for PDGFR $\alpha$  (Coats et al. 1994).

## **2.7 Role of PDGFs in physiology and disease**

Clear insights into PDGF's physiological functions have emerged from genetic studies in mice targeting both PDGFs and their receptors. An overview of mouse mutants and their phenotypes have been reviewed in Hoch and Soriano 2003; Betsholtz 2004.

Overall, from these genetic studies, the PDGF/PDGFR system is important during embryogenesis, mostly in embryonic blood vessel growth, and organogenesis (Heldin and Westermark 1999; Demoulin and Essaghir 2014; Manzat Saplacan et al. 2017). The proof for this vital role during embryonic development stemmed from the discovery that that deletion or null mutation of either receptor is embryonically lethal (Boström et al. 1996; Soriano 1997; Betsholtz 2003; Tallquist and Kazlauskas 2004) where PDGFR $\alpha$  knockouts have shown the most severe phenotype (Soriano 1997; Betsholtz 2003; Ding et al. 2004).

Signalling through PDGFR $\alpha$  is thus required for the development of the intestinal villus, facial skeleton, lungs, astrocytes, and oligodendrocytes. It is also necessary for spermatogenesis, hair follicle morphogenesis, in the regulation of the development and maturation of non-neuronal neural crest and chondrocytes (Fruttiger et al. 1999; Karlsson et al. 1999, 2000; Östman and Heldin 2001; Boström et al. 2002; Tallquist and Kazlauskas 2004; Rönstrand 2010).

Signalling through PDGFR $\beta$  is involved in recruiting pericyte to capillaries, maturation of white adipocytes, SMCs development in vessels, as well as mesangial cells development in the kidney (Levéen et al. 1994; Soriano 1994; Andrae et al. 2008;

Rönnstrand 2010). It also regulates interstitial fluid pressure, and can therefore control fluid transport from the vessels to surrounding tissues (Heuchel et al. 1999).

In adults, the physiological function of PDGFR signalling is seen in tissue repair and wound healing via the stimulation of cells like SMCs, fibroblasts, and various inflammatory cells (Robson et al. 1992; LeGrand 1998; Heldin and Westermark 1999; Rönnstrand 2010).

PDGF functions have thus been associated with or linked to a wide range of diseases that have been broadly classified into three; tumours, vascular diseases and fibrosis which have been reviewed extensively in Andrae et al. 2008.

In tumours originating from PDGFR<sup>+</sup> cells such as in glioblastomas and sarcomas (Hermanson et al. 1992; Smits et al. 1992).

Vascular diseases like atherosclerosis and restenosis (Ross 1993; Rutherford et al. 1997; Raines 2004), pulmonary hypertension (Humbert et al. 1998; Balasubramaniam et al. 2003; Schermuly et al. 2005), and in retinal vascular diseases such as proliferative vitreoretinopathy, proliferative diabetic retinopathy, and CNV (Akiyama et al. 2006; Jo et al. 2006).

Fibrotic diseases like pulmonary fibrosis (both PDGFR $\alpha$  and PDGFR $\beta$ ) (Yi et al. 1996; Hoyle et al. 1999), liver fibrosis (and its end stage cirrhosis) (PDGFR $\beta$  only) (Pinzani et al. 1994, 1996; Bonner 2004), dermal fibrosis (Bonner 2004; Distler et al. 2007), renal fibrosis (Johnson et al. 1992; Tang et al. 1996; Floege et al. 1999), and cardiac fibrosis (Pontén et al. 2005; Tuuminen et al. 2006).

## CHAPTER THREE: MATERIALS AND METHODS

### 3.1 Materials

#### 3.1.1 Cells

**Table 3.1** Cell lines and primary cells

| Cell lines                       | Origin  |
|----------------------------------|---|
| BV-2 murine microglial cell line | Murine primary microglial cultures isolated from one week old C57BL/6 mice and infected with a v-raf/v-myc recombinant retrovirus (Blasi et al. 1990) |
| 661W photoreceptor cell line     | Prof. Muayyad Al-Ubaidi, University of Oklahoma Health Sciences Center, Oklahoma, USA   |
| Primary cells                    | Origin  |
| Primary microglial cells         | Mixed glial cultures isolated from the brains of 1-2 day old C57BL/6J mice (Spittau et al. 2013)  |

#### 3.1.2 Culture media

**Table 3.2** Reagents and culture media formula

| Cell culture reagents                              | Manufacturer, Cat. No   |
|--|---|
| Antibiotic/Antimycotic Solution (100x), Stabilised | Sigma-Aldrich, #A5955   |
| Dulbecco's Modified Eagle Medium - HG (DMEM-HG)    | Sigma-Aldrich, #D6429   |
| Dulbecco's Phosphate-Buffered Saline (DPBS)        | Gibco, #14190-094   |
| Fetal Calf Serum (FCS)                             | Gibco, #10270-106   |
| Hank's Balanced salt Solution (HBSS)               | Gibco, #14025092  |
| L-Glutamine (200mM)                                | Gibco, #25030081  |
| Penicillin/Streptomycin                            | Gibco, #15140-122   |
| Roswell Park Memorial Institute (RPMI) 1640 medium | Gibco, #21875034  |
| Trypsin/EDTA                                       | Sigma-Aldrich, #T3924   |
| $\beta$ -mercaptoethanol                           | Sigma-Aldrich, #M-7154  |
| Opti-MEM I   | Gibco, #31985-070   |
| Cells  | Media Formula   |
| BV-2 murine microglial cell line                   | RPMI 1640<br>5 % FCS<br>1 % L-Glutamine<br>1 % Penicillin/Streptomycin<br>195 nM $\beta$ -mercaptoethanol |
| 661W photoreceptor-like cell line                  | DMEM HG<br>5 % FCS<br>1 % Penicillin/Streptomycin   |

|                          |  |
|--------------------------|--|
|                          | 1 % Antibiotic/Antimycotic                         |
| Primary microglial cells | DMEM HG<br>10 % FCS<br>1 % Penicillin/Streptomycin |

### 3.1.3 Buffers and solutions

**Table 3.3** Recipes for buffers and solutions

| Buffer/Solution                  | Formula  | Manufacturer, Cat. No   |
|----------------------------------|--|---|
| 1x PBS, pH 7.4                   | 137 mM Sodium chloride (NaCl)<br>2.7 mM Potassium chloride (KCl)<br>10 mM Disodium phosphate (Na <sub>2</sub> HPO <sub>4</sub> )<br>1.8 mM Monopotassium phosphate (KH <sub>2</sub> PO <sub>4</sub> )  | Amresco, #E404<br>1 tablet/100 ml ddH <sub>2</sub> O  |
| 1x TBS-T                         | 150 mM NaCl<br>200 mM Tris<br>0.1 % v/v Tween <sup>®</sup> 20  | Merck, #106400<br>Roth, #4855.3<br>Merck, #822184   |
| Antibody solution (Western Blot) | 5 % w/v Bovine serum albumin (BSA)<br>in 1x TBS-T  | Roth, #3854.2<br>see above  |
| Membrane blocking buffer         | 5 % w/v non-fat milk powder<br>in 1x TBS-T   | Roth, #T145.3<br>see above  |
| RIPA buffer                      | 50 mM Tris-HCl pH 7.4<br>150 mM NaCl<br>1 % v/v NP-40<br>0.5 % w/v Sodium deoxycholate<br>0.1 % w/v Sodium dodecyl sulfate (SDS)<br>2mM Phenylmethanesulfonyl fluoride (PMSF)<br>Complete™ mini protease inhibitor<br>(±) 1 % Phosphatase inhibitor cocktail | see above<br>see above<br>Calbiochem, #492016<br>Sigma-Aldrich, #D6750<br>Serva, #20765.03<br>Applichem, #A0999<br>Roche, #11836153001<br>Cell Signalling Technology (CST), #5870 |
| Running buffer                   | 192 mM Glycine<br>250 mM Tris  | AppliChem, #A1067<br>see above  |



|   |   |                        |
|---|---|------------------------|
|   | 0.1 % w/v SDS                           | see above              |
| Transfer buffer                                       | 192 mM Glycine                          | see above              |
|   | 250 mM Tris                             | see above              |
|   | 20 % v/v Methanol                       | Chemsolute, #1437.2511 |
| Stripping buffer, pH 2.2                              | 15g Glycine                             | see above              |
|   | 1g SDS                                  | see above              |
|   | 10mL Tween <sup>®</sup> 20              | see above              |
|   | in 1L ddH <sub>2</sub> O                |                        |
| Antibody solution                                     | 2.5 % Goat serum                        | Abcam, #AB7481         |
| Immunocytochemistry<br>(ICC)                          | 0.1 % v/v Triton X-100                  | Sigma-Aldrich, #T8787  |
|   | in 1x PBS                               | see above              |
| Blocking buffer (ICC)                                 | 10 % Goat serum                         | see above              |
|   | 0.3 % v/v Triton X-100                  | see above              |
|   | in 1x PBS                               | see above              |
| Wash buffer, pH 7.2-7.4                               | 0.05 % v/v Tween <sup>®</sup> 20        | see above              |
|   | in 1x DPBS                              | see above              |
| Reagent diluent<br>(filtered), pH 7.2-7.4             | 1 % w/v BSA                             | see above              |
|   | in 1x DPBS                              | see above              |
| Stop solution<br>(2N H <sub>2</sub> SO <sub>4</sub> ) | 96 % H <sub>2</sub> SO <sub>4</sub>     | Roth, #4623            |
|   | in dd H <sub>2</sub> O (1: 18 dilution) |                        |

### 3.1.4 SDS-Poly Acrylamide Gel Electrophoresis (PAGE)

**Table 3.4** Recipes for SDS-PAGE gels

| Gels          | Formula                             | Manufacturer, Cat. No |
|---------------|-------------------------------------|-----------------------|
| Resolving gel | 8 % (or 15 %) v/v Acrylamide        | Roth, #A124.1         |
|               | 0.4 M Tris pH 8.8                   | see above             |
|               | 0.1 % w/v SDS                       | see above             |
|               | 0.1 % w/v Ammonium persulfate (APS) | Sigma-Aldrich, #A3678 |
|               | 0.01 % v/v TEMED                    | Roth, #2367.1         |
| Stacking gel  | 5 % v/v Acrylamide                  | see above             |
|               | 0.125 M Tris pH 6.8                 | see above             |
|               | 0.1 % w/v SDS                       | see above             |
|               | 0.1 % w/v APS                       | see above             |
|               | 0.005 % v/v TEMED                   | see above             |

### 3.1.5 Kits

**Table 3.5** Commercially available kits

| <b>Kit</b>   | <b>Manufacturer, Cat. No</b>    |
|--|---------------------------------|
| CellTiter 96 <sup>®</sup> Cell Proliferation Assay             | Promega, #G4000                 |
| Caspase-Glo <sup>®</sup> 3/7 Assay                             | Promega, #G8090                 |
| DCFDA Cellular ROS Detection Assay kit                         | Abcam, #ab113851                |
| Mouse CCL2/JE/MCP-1 DuoSet <sup>®</sup> ELISA                  | R&D SYSTEMS, #DY479-05          |
| NucleoSpin <sup>®</sup> RNA isolation kit                      | Macherey-Nagel, #740955         |
| Pierce <sup>™</sup> BCA Protein Assay kit                      | ThermoFisher Scientific, #23225 |
| RevertAid RT Kit   | ThermoFisher Scientific, #K1691 |
| SignalFire <sup>™</sup> Elite ECL Reagent                      | CST, #12757                     |
| Takyon <sup>™</sup> No Rox Probe 2x MasterMix dTTP             | Eurogentec, #UF-NPMT-B0701      |
| Takyon <sup>™</sup> No Rox SYBR <sup>®</sup> 2x MasterMix dTTP | Eurogentec, #UF-NSMT-B0710      |

### 3.1.6 Antibodies

**Table 3.6** Primary and secondary antibodies and stains

| <b>Antibodies and stains</b>   | <b>Dilution</b>            | <b>Manufacturer, Cat. No</b>      |
|--|----------------------------|-----------------------------------|
| Anti-PDGFB Rabbit polyclonal   | 1:1000 (WB)<br>1:100 (ICC) | Abcam, #ab23914                   |
| PDGF Receptor $\beta$ (28E1) Rabbit monoclonal   | 1:100                      | Cell Signalling Technology, #3169 |
| Phospho-PDGFR Receptor $\beta$ (Tyr1009) (42F9) Rabbit monoclonal                          | 1:1000                     | Cell Signalling Technology, #3124 |
| Anti-Iba1, Goat polyclonal   | 1:100                      | Abcam, #ab5076                    |
| SAPK/JNK Antibody Rabbit Polyclonal  | 1:1000                     | Cell Signalling Technology, #9252 |
| Phospho-SAPK/JNK (Thr183/Tyr185) (81E11) Rabbit monoclonal                                 | 1:1000                     | Cell Signalling Technology, #4668 |
| Akt (pan) (C67E7) Rabbit monoclonal  | 1:1000                     | Cell Signalling Technology, #4691 |
| Phospho-Akt (Ser473) (D9E) XP <sup>®</sup> Rabbit monoclonal                               | 1:2000                     | Cell Signalling Technology, #4060 |
| p44/42 MAPK (Erk1/2) (137F5) Rabbit monoclonal   | 1:1000                     | Cell Signalling Technology, #4695 |
| Phospho-p44/42 MAPK (Erk1/2) (Thr202/Tyr204) (D13.14.4E) XP <sup>®</sup> Rabbit monoclonal | 1:2000                     | Cell Signalling Technology, #4370 |

|   |           |                                    |
|---|-----------|------------------------------------|
| p38 MAPK (D13E1) XP <sup>®</sup> Rabbit monoclonal                        | 1:1000    | Cell Signalling Technology, #8690  |
| Phospho-p38 MAPK (Thr180/Tyr182) (D3F9) XP <sup>®</sup> Rabbit monoclonal | 1:1000    | Cell Signalling Technology, #4511  |
| β-Actin (C4) Mouse monoclonal   | 1:500     | Santa Cruz Biotechnology, sc-47778 |
| Alexa Fluor <sup>®</sup> 488 goat anti-rabbit IgG, polyclonal             | 1:2000    | ThermoFisher Scientific, #A11008   |
| Alexa Fluor <sup>®</sup> 488 donkey anti-goat IgG, polyclonal             | 1:1000    | ThermoFisher Scientific, #A11055   |
| goat anti-rabbit IgG-HRP, polyclonal                                      | 1:4000    | Agilent Dako, #P0448               |
| goat anti-mouse IgG-HRP, polyclonal                                       | 1:4000    | Agilent Dako, #P0447               |
| DAPI  | 0.1 µg/ml | Invitrogen, #D1306                 |
| Phalloidin-TRITC  | 0.1 µg/ml | Sigma-Aldrich, #P1951              |

### 3.1.7 Primers and probes

**Table 3.7** TaqMan (Probe-based) and SYBR<sup>®</sup> Green primers

| TaqMan primers  |                          |                          |             |
|-----------------|--------------------------|--------------------------|-------------|
| Gene            | Forward primer (5' → 3') | Reverse primer (5' → 3') | UPL Probe # |
| m <i>Atp5b</i>  | ggcacaatgcaggaaagg       | tcagcaggcacatagatagcc    | 77          |
| m <i>Pdgfa</i>  | gatgaggacctgggcttg       | gatcaactcccggggtatct     | 68          |
| m <i>Pdgfb</i>  | cggcctgtgactagaagtcc     | gagcttgaggcgtcttg        | 32          |
| m <i>Pdgfc</i>  | tgtgtcccacgtaaagttaaaa   | tcagtgagtgacttatgcaatcc  | 109         |
| m <i>Pdgfra</i> | ttaagccgggtcccaacct      | ctagacctggctgtgggttt     | 83          |
| m <i>Pdgfrβ</i> | ggcttctgggtgaaggctat     | gcaggatggctactcctcag     | 62          |
| m <i>Ccl2</i>   | catccacgtgttggtca        | gatcatcttgctggtgaatgagt  | 62          |
| m <i>Cox2</i>   | gatgctctccgagctgtg       | ggattggaacagcaaggattt    | 45          |
| m <i>Tnfa</i>   | ctgtagcccacgtcgtagc      | ttgagatccatgccgttg       | 78          |
| m <i>Nox1</i>   | cttgaccgattgcttttat      | cattagatgggtgcatgacaa    | 3           |
| m <i>Ccl3</i>   | tgcccttgctgttcttctct     | gtggaatcttccggctgtag     | 40          |
| m <i>Ccl5</i>   | tgcagaggactctgagacagc    | gagtgggtgccgagccata      | 110         |
| m <i>P2ry12</i> | cccggagacactcatatcctt    | gtcccaggggagaagggtg      | 102         |
| m <i>Cd36</i>   | ttgaaaagtctcggacattgag   | tcagatccgaacacagcgta     | 6           |
| m <i>Trem2</i>  | tgggacctctccaccagtt      | gtggtgttgagggtctgg       | 18          |
| m <i>Msr1</i>   | ctggacaaactgggtccacct    | gtccccgatcacctttaaca     | 1           |
| m <i>Scarb1</i> | cttcatgacacccgaatcct     | caaacacccttgattcgttg     | 41          |

|                                 |                          |                         |    |
|---------------------------------|--------------------------|-------------------------|----|
| m <i>Gpx1</i>                   | gtttcccgtgcaatcagttc     | caggtcggacgtacttgagg    | 2  |
| m <i>Gpx4</i>                   | ccgtctgagccgcttactta     | gctgagaattcgtgcatgg     | 71 |
| m <i>Gsr</i>                    | actatgacaacatccctactgtgg | cccatacttatgaacagcttcgt | 83 |
| m <i>Catalase</i>               | ccttcaagttggttaatgcaga   | caagttttgatgccctggt     | 34 |
| m <i>Sod1</i>                   | caggacctcattttaatcctcac  | tgcccaggtctccaacat      | 49 |
| m <i>Sod2</i>                   | tgctctaatacaggaccattg    | gtagtaagcgtgctcccacac   | 3  |
| m <i>Il-6</i>                   | gatggatgctaccaaactggat   | ccaggtagctatggactccaga  | 6  |
| m <i>Il-1<math>\beta</math></i> | agttgacggaccccaaaag      | agctggatgctctcatcagg    | 38 |

**SYBR<sup>®</sup> Green Primers**

| Gene           | Forward primer (5' → 3') | Reverse primer (5' → 3') |
|----------------|--------------------------|--------------------------|
| m <i>Actin</i> | aggaggagcaatgatcttg      | agacctgtacgccaacacag     |
| m <i>Nox2</i>  | ggttccagtgctgttgct       | gcggtgtgcagtgctatcat     |

**3.1.8 siRNA sequences****Table 3.8** ON-TARGETplus SMARTpool siRNA sequences

| Gene                           | Target sequence (5'-3') | Antisense (5'-3')   | Cat. No     |
|--------------------------------|-------------------------|---------------------|-------------|
| <i>Pdgfra</i>                  | CCAGCGAGUUUAAUGUUUA     | UAAACAUUAAACUCGCUGG | J-048730-05 |
|                                | AGGUACAGCUUAUGGAUUA     | UAAUCCAUAAGCUGCACCU | J-048730-06 |
|                                | GAGACAGGUUCCAGUAGUU     | AACUACUGGAACCUGUCUC | J-048730-07 |
|                                | UAUCGUGGCUGAAGGACAA     | UUGUCCUUCAGCCACGAUA | J-048730-08 |
| <i>Pdgfr<math>\beta</math></i> | CAGCGAGGUUUCACUGGUA     | UACCAGUGAAACCUCGCUG | J-048218-05 |
|                                | GAACGACCAUGGCGAUGAG     | CUCAUCGCCAUGGUCGUUC | J-048218-06 |
|                                | GGAAGCGUAUCUAUAUCUU     | AAGAUUAAGAUACGCUUGC | J-048218-07 |
|                                | UAGAUUACGUGCCCAUGUU     | AACAUGGGCACGUAAUCUA | J-048218-08 |

**3.1.9 General consumables****Table 3.9** Consumables

| Consumables                          | Manufacturer, Cat. No.   |
|--------------------------------------|--------------------------|
| Nitrocellulose membrane 0.45 $\mu$ m | Bio-Rad, #1620115        |
| 1.5 ml micro tube                    | Sarstedt, #72.690        |
| 1.5 ml micro tube black              | Roth, #AA80.1            |
| 12-well cell culture plates          | Sarstedt, #83.3921       |
| 15 ml reaction tube                  | Sarstedt, #62.554.502    |
| 2 ml micro tube                      | Sarstedt, #72.689        |
| 30 $\mu$ l Impact 384 tips           | Thermo Scientific, #7431 |
| 50 ml reaction tube                  | Sarstedt, #62.554.254    |
| 6-well cell culture plates           | Sarstedt, #83.3920       |
| 96-well microtitre plate             | Sarstedt, #83.3924       |
| Biosphere R filter tips 1000 $\mu$ L | Sarstedt, #70.762.211    |
| Biosphere R filter tips 2.5 $\mu$ L  | Sarstedt, #70.1130.212   |

|  |                                      |
|--|--------------------------------------|
| Biosphere R filter tips 200 µL                 | Sarstedt, #70.760.211                |
| Black clear-bottomed 96-well microtitre plates | ThermoFischer Scientific, #611F96BK  |
| Cell Culture Dish, 100 x 20 mm                 | Eppendorf®, #0030702115              |
| Cell scraper                                   | Sarstedt, #83.1830                   |
| Cover glasses 18x18mm                          | Th.Geyer, #7695023                   |
| FrameStar® 384-well plates with seal           | 4titude, #4ti-0382                   |
| Gloves   | Dermagrip, #100176                   |
| Nunc MaxiSorp® flat-bottom 96-well plates      | ThermoFischer Scientific, #44-2404   |
| PCR stripes                                    | Kisker Biotech, #G003-SF             |
| Steriflip-HV, 0.45 µm, PVDF, radio-sterilized  | Sigma-Aldrich, #SE1M003M00           |
| Superfrost Plus™ Microscope Slides             | ThermoFischer Scientific, #J1800AMNT |
| T-75 culture flask                             | Sarstedt, #83.3911.002               |
| Vannas-Tübingen Spring Scissors                | Fine Science Tools, #15003-08        |
| White-walled 96-well microtiter plates         | Costar, #3912                        |

### 3.1.10 Compounds, chemicals and reagents

**Table 3.10** Cytokines, compounds, chemicals and other reagents

| <b>Cytokines, compounds and siRNAs</b>         | <b>Manufacturer, Cat. No.</b> |
|--|-------------------------------|
| Recombinant human PDGF-AA                      | PeptoTech, #100-13A           |
| Recombinant human PDGF-AB                      | PeptoTech, #100-00AB          |
| Recombinant human PDGF-BB                      | PeptoTech, #100-14B           |
| Recombinant human PDGF-CC                      | PeptoTech, #100-00CC          |
| LPS from <i>E. coli</i> 0111:B4                | Sigma-Aldrich, #L4391         |
| Anti-mouse CD140a (APA5), Functional Grade     | Invitrogen, #16-1401-82       |
| Anti-mouse CD140b (APB5), Functional Grade     | Invitrogen, #16-1402-82       |
| Rat IgG2a kappa (eBR2a), Functional Grade      | Invitrogen, #16-4321-82       |
| U0126, MEK1 and MEK2 Inhibitor                 | InvivoGen, #tlrl-u0126        |
| SP600125                                       | PeptoTech, #1295666           |
|  | InvivoGen, #tlrl-ly29         |
|  | Dharmacon, #L-048730-00-0005  |
| LY294002, PI3K Inhibitor                       |                               |
| Mouse PDGFR $\alpha$ siRNA - SMARTpool, 5 nmol | Dharmacon, #L-048218-00-0005  |
| Mouse PDGFR $\beta$ siRNA - SMARTpool, 5 nmol  |                               |
| Non-targeting pool                             | Dharmacon, #D-001810-10-05    |
| <b>Chemicals and reagents</b>                  | <b>Manufacturer, Cat. No.</b> |
| 5x siRNA Buffer                                | Dharmacon, #B-002000-UB-100   |
| CellTracker™ CM-Dil                            | Invitrogen, #C7001            |
| Dimethylsulfoxide (DMSO)                       | Serva, #20385.01              |

|  |                                   |
|--|-----------------------------------|
| Ethanol 100%   | Applichem, #A3678                 |
| Ethanol 70 %   | Applichem, #A2192                 |
| Fluorescence Mounting Medium                         | Dako, #S302380-2                  |
| Isopropanol  | Merck, #100995                    |
| Laemmli sample buffer                                | Bio-Rad, #161-0747                |
| Lipofectamine™ 3000 Transfection Reagent             | ThermoFisher Scientific, L3000015 |
| Methanol   | Chemosolution, #1437.2511         |
| PageRuler™ Plus Prestained Protein Ladder            | ThermoFisher Scientific, #26619   |
| PageRuler™ Prestained Protein Ladder                 | ThermoFisher Scientific, #26616   |
| Poly-d-lysine  | Sigma-Aldrich, #P6407             |
| Micro particles based on polystyrene, dark blue, 1µm | Sigma-Aldrich, #51972-5ML-F       |
| RNase away   | Molecular Biopro., #70003         |
| Roti® HistoFix 4%                                    | Roth, #P087.4                     |
| Substrate Reagent Pack                               | R&D Systems®, #DY999              |

### 3.1.11 Devices

**Table 3.11** Laboratory devices

| <b>Devices</b>                  | <b>Manufacturer</b>      |
|---------------------------------|--------------------------|
| Adventurer Pro balance          | Ohaus®                   |
| ApoTome.2                       | Zeiss                    |
| AxioCam MRC vert. A1 camera     | Zeiss                    |
| AxioCam MRm camera              | Zeiss                    |
| Centrifuge 5415 R               | Eppendorf                |
| Centrifuge Mini Star            | VWR International        |
| Explorer R Ex 124 balance       | Ohaus®                   |
| Galaxy 170S CO2 incubator       | New Brunswick Scientific |
| Heraeus Labofuge 400 R          | Thermo Scientific        |
| Imager.M2 microscope            | Zeiss                    |
| Infinite® F200 Pro plate reader | Tecan                    |
| LightCycler® 480 Instrument II  | Roche Applied Science    |
| Matrix™ Multichannel Pipette    | ThermoFisher Scientific  |
| Mini-Protean® Tetra System      | Bio-Rad                  |
| MiniTrans-Blot® Cell Module     | Bio-Rad                  |
| MSC-Advantage hood              | Thermo Scientific        |
| Multimagell                     | Alpha Innotech           |
| NanoDrop 2000 Spectrophotometer | Thermo Scientific        |

|                                       |                        |
|---------------------------------------|------------------------|
| Neubauer counting chamber             | OptikLabor             |
| Orbital incubator S1500               | Stuart®                |
| PCR workstation                       | VWR International      |
| peQSTAR 2x cycler                     | peQlab                 |
| See-saw rocker SSL4                   | Stuart®                |
| Thermomixer compact                   | Eppendorf              |
| TW20 watherbath                       | Julabo                 |
| VisiLight® binocular                  | VWR International      |
| Vortex-genie®                         | Scientific Industries™ |
| VWR Electrophoresis Power Source 250V | VWR International      |

### 3.1.12 Software

**Table 3.12** Software

| Software                        | Manufacturer                  |
|---------------------------------|-------------------------------|
| AlphaView FluorChem FC2         | Cell Biosciences              |
| CSI Adobe Creative Suite        | Adobe Systems                 |
| GraphPad Prism version 7        | GraphPad Software, Inc.       |
| ImageJ 1.50i                    | National Institutes of Health |
| LightCycler® 480 software 1.5.1 | Roche Applied Science         |
| Nanodrop2000/2000c software     | ThermoFisher Scientific       |
| Office Suite 2013               | Microsoft Corporation         |
| Tecan i-control 1.9             | PerkinElmer                   |
| Zen 2012                        | Zeiss                         |

## 3.2 Methods

### 3.2.1 Cell culture

#### 3.2.1.1 Maintenance and sub-culturing of cell lines

Cell lines used in this study were murine BV-2 microglia and 661W photoreceptor cells. The cell lines were maintained appropriately in their respective media (Table 3.2) in T-75 flasks at 37°C in a humidified atmosphere of 5% CO<sub>2</sub>. Cells were routinely sub-cultured every 2 to 3 days depending on confluency. BV-2 microglial cells were rinsed with 5ml sterile 1x DPBS and detached by gentle scraping in freshly pre-warmed media. 661W cells were detached by incubation with 5ml trypsin/EDTA (1x) at 37°C, 5% CO<sub>2</sub> for 5 minutes. Flasks were checked under the microscope to ensure cell layer dispersion before an equal volume of complete media was added to stop the trypsin reaction. The cell suspension was transferred to a 50ml falcon tube and centrifuged at 1500 rpm for 5 minutes. Trypsin containing media was aspirated and cells re-

suspended in fresh media. All cells were split at a 1:5 ratio and appropriate volume re-suspended in flasks pre-filled with 10ml of complete media. Cells were maintained up to a maximum of 23 passages.

### **3.2.1.2 Primary microglia cell culture**

Mixed glia cultures were prepared from 1-2 day old C57BL/6J pups as previously described by Spittau et al., 2013 with minor modifications. Briefly, pups were decapitated and isolated whole brains were rinsed in ice-cold HBSS twice. The brain surface were freed from blood vessels and meninges using fine forceps under the binocular microscope. Cleaned brains were enzymatically dissociated (by dicing into small pieces and immersion in a 2ml Eppendorf tube pre-filled with 1ml 1x trypsin/EDTA) for 15 minutes at 37°C in Eppendorf Thermomixer. Subsequently, an equal amount of ice-cold FCS previously supplemented with DNase at a final concentration of 0.5mg/ml were added. Brains were then mechanically dissociated with a 1000µl and then a 200µl pipette tip. Dissociated cells were centrifuged at 500 RCF for 10 minutes, supernatants were discarded and cells re-suspended in appropriate media (Table 3.2). The cell suspension was transferred at a density of 2 brains/T-75 flasks pre-coated with poly-D-lysine (1µg/cm<sup>2</sup>). The mixed glia culture was maintained at 37°C in a humidified atmosphere at 5% CO<sub>2</sub>. On the two successive days following isolation (i.e., DIV 2 and 3), cultures were washed twice with 1x DPBS and fresh complete medium was added. Microglial cells were then harvested from adherent astrocytes at around 10-14 days *in-vitro*, by shaking flasks at 250 rpm for 2-3 hours at 37°C. The media containing microglial cells were collected in a 50ml falcon tube and centrifuged at 800 RCF or 10 minutes. Microglial cell purity was assessed by staining for ionized calcium-binding adaptor (Iba-1) protein, a microglia marker (Appendix fig. 1A). Harvested microglial cells were counted and seeded in 12-well culture plates for experiments.

### **3.2.1.3 Cell seeding**

BV-2 cells were seeded either in 6-well culture plates at a density of 3x10<sup>5</sup> cells/well in 2ml media or in 12-well culture plates at a density of 2x10<sup>5</sup> cells/well in 1ml media unless otherwise indicated. Primary microglia cells were seeded in 12-well culture plates at a density of 2x10<sup>5</sup>/well in 1ml media. Seeded cells were allowed to attach overnight, medium was changed prior to start of experiment and cells were treated according to the different experiments.



#### 3.2.1.4 Cell treatment

**BV-2 cells:** For the expression of PDGF ligands and their receptors, cells were treated with 50 and 100ng/ml LPS for 6 hours. For the pharmacological inhibition studies; in the first experiment, cells were treated with LPS 100ng/ml for 6 hours with or without 30 minutes pre-treatment with 10µg/ml IgG, APA5 or APB5; in the second experiment, cells were treated with 50ng/ml recombinant human PDGF ligands for 3 hours with or without 1 hour pre-treatment with 10µg/ml APA5 or APB5.

APA5 and APB5 are PDGFR blocking antibodies for R $\alpha$  and R $\beta$  respectively with IgG serving as the isotype control. APA5, APB5 and IgG were diluted in DPBS and the concentrations used were based on concentration testing.

For western blot, in one experiment, cells were treated with 100ng/ml LPS in a time kinetic study (3, 6, 24 and 48 hours) while in separate experiments, cells were treated with 50ng/ml PDGF-BB also in a time kinetic study (5, 15, 30, 60, 120 and 180 minutes).

In the kinase pathway inhibition studies, cells were pre-treated with inhibitors specific for MEK (U0126, 10µM), JNK (SP600125, 10µM), and PI3K (LY294002, 10µM) for 1 hour prior to 50ng/ml PDGF ligand treatment for 3 hours. The inhibitors were prepared (reconstituting in DMSO) according to product leaflet and stored in aliquots at -20°C where the final concentration of DMSO used on cells was less than 0.05%. The concentrations utilised for these small molecule kinase inhibitors were based on previously published data (Yao et al. 2009; Bethel-Brown et al. 2012) and cell cytotoxicity assay.

For the indicated experiments, LPS was diluted in DPBS which served as the vehicle control. PDGF ligands were first reconstituted in water and further diluted in DPBS containing 0.1% BSA as carrier protein and this served as the vehicle control.

**661W cells:** Cells were treated with microglia conditioned medium (MCM). Microglia conditioned medium was obtained from 24 hours of vehicle treated and 50ng/ml PDGF ligand treated BV-2 cells and were centrifuged at 4000 RCF for 10 minutes. Conditioned medium was carefully transferred and stored at -80°C until needed.

**Primary microglia cells:** In one set of experiments, cells were treated with 50ng/ml recombinant PDGF ligands for 3 hours. In another set of experiment, cells were pre-treated for 1 hour with kinase pathway inhibitors prior to 3 hours PDGF ligand treatment.

All experiments involving treatment of cells with recombinant PDGF ligands were done under serum-free conditions since the PDGF promoter is known to have serum response elements (Perez-Albuerne et al. 1993) and serum induces PDGF (Dhillon et al. 2007).

### **3.2.2 MTT cell proliferation and or viability assay**

The MTT cell proliferation assay is a colorimetric assay measuring the rate of cell proliferation and conversely cell viability reduction when metabolic processes results in necrosis or apoptosis. It is based on the ability of mitochondrial dehydrogenase enzymes (Mosmann 1983) primarily succinate dehydrogenase to reduce the yellow water-soluble tetrazolium dye, 3-[4,5-dimethylthiazole-2-yl]-2,5-diphenyltetrazolium bromide (MTT) to its insoluble purple formazan (MTT-formazan) in metabolically active cells (Wang et al. 1996; Vajrabhaya and Korsuwannawong 2018). Because this reduction is only feasible in viable cells, the amount of purple formazan formed is proportional to the number of viable cells (Mosmann 1983).

BV-2 microglial cells were seeded at a density of 10,000 cells/well in 100µl in transparent 96-well culture plates and allowed to attach overnight. Cytotoxic effects of increasing concentrations (1-30µg/ml) of APA5 and APB5 were evaluated for 48 hours (Appendix fig 2A and B). In separate experiments, cytotoxic effects of U0126, SP600125, and LY294002 at 10µM was also evaluated for 4 hours (Appendix fig. 2C). At the termination of experiments, 15µl of the dye solution was added to each well (avoiding skin or eyes contact as the dye solution is an irritant) and plates re-incubated at 37°C for 4 hours in a humidified 5% CO<sub>2</sub> atmosphere. In each of the experiments, control wells (vehicle in culture medium without cells plus the tetrazolium reagent) were included in the set-up to test for chemical interference effect. Reaction was stopped by addition of 100µl solubilization solution/stop mix to each well, one hour after addition of solubilization solution/stop mix, plate was mixed to get a uniformly coloured solution while avoiding bubbles as this could cause interference with accurate recording of absorbance values. Absorbance measurements were taken with the Tecan Infinite® F200 pro microplate reader at a wavelength of 570nm and values of no-cell control were subtracted from all experimental wells to obtain corrected absorbance values.

### **3.2.3 Transcript analysis**

#### **3.2.3.1 RNA Isolation**

Total RNA was extracted using the NucleoSpin® RNA Mini Kit according to the manufacturer's instructions. At the termination of experiment and prior to addition of lysis buffer, culture medium was removed and the cells washed with 1x DPBS. Cells were thereafter lysed with 350µl of lysis buffer RA1 supplemented with 3.5µl of β-mercaptoethanol as reducing agent.

The lysis buffer inactivates RNases thus creating suitable binding conditions which favours adsorption of RNA to the silica membrane. Thereafter, rDNase solution is applied directly onto the silica membrane to remove contaminating DNA which also binds to the silica membrane. Subsequent washing steps with two different buffers aids to remove salts and other metabolites.

In a final step, RNA is eluted from silica-based columns in 40µl RNase-free water and concentrations measured with 1µl using NanoDrop™ spectrophotometer. Absorbance is proportional to the RNA concentration and nucleotides absorb ultraviolet light at 260nm wavelength. Therefore, absorbance ratio at 260nm and 280nm is an assessment of the purity of DNA and RNA. Thus, a 260/280 ratio of approximately 2.0 is accepted as "pure" for RNA samples and subsequently reverse transcribed. Samples were either reverse transcribed immediately or stored at -80°C until further use.

#### **3.2.3.2 Reverse transcription**

First-strand cDNA synthesis was performed with 0.1ng - 5µg of RNA in a 20µl final volume using the RevertAid™ H Minus First Strand cDNA synthesis kit. The resulting cDNA was diluted with nuclease-free water to a final concentration of 20ng/µl which was immediately used for quantitative PCR or stored at -20°C until further use.

#### **3.2.3.3 Quantitative PCR (qPCR)**

Quantitative amplifications of reverse transcribed (RT) cDNA were performed with the LightCycler® 480 Instrument II. The use of fluorescent signals affords the quantification of gene expression by the detection of the amplicon (PCR product) at every PCR cycle. In this study, TaqMan (also known as fluorogenic 5' nuclease assay) and SYBR® green I (SG) detection chemistries have been used for different genes.

The TaqMan assay is based on the principle of the specific hybridisation of a dual-labelled TaqMan (Holland et al. 1991) probe to the amplicon. At the 5' end of this

probe, is a fluorescent reporter dye while at the 3' end is a quencher dye and via complementary binding, the probe binds to the target sequence between the forward and the reverse primer at the initiation of reaction. The close proximity of the reporter and the quencher dye allows the suppression of the reporter fluorescence, thus, inhibiting signal. As the amplification primer is extended in the course of the reaction, the probe is cleaved by *Taq* polymerase, spatially separating the reporter and quencher dye, allowing reporter dye fluorescence detection. As the amount of target gene increases, the fluorescence intensity also increase and thus more probe cleavage (Butler 2012). The reaction component can be seen in Table 3.13. Incubation was done at 95°C to activate the polymerase and reaction was subjected to 40 amplification cycles as in Table 3.14. Measurements were done in triplicates, run validity was confirmed with both positive and negative controls.

**Table 3.13** TaqMan qPCR components

| TaqMan Assay                     |             |        |
|----------------------------------|-------------|--------|
| Reaction components              | Volume (µL) | Conc.  |
| Template DNA (cDNA)              | 2.5         | 50 ng  |
| Forward primer                   | 1           | 1 µM   |
| Reverse primer                   | 1           | 1 µM   |
| Roche probe                      | 0.125       | 125 nM |
| 2x Probe MasterMix               | 5           | 1x     |
| Nuclease-free ddH <sub>2</sub> O | 0.375       |        |
| Total Mix/reaction               | 10          |        |

**Table 3.14** TaqMan qPCR program

| Program Name         | Temperature | Time       |           |
|----------------------|-------------|------------|-----------|
| Initial denaturation | 95 °C       | 5 minutes  | 1 cycle   |
| Cycling              | 95 °C       | 15 seconds | 40 cycles |
|                      | 60 °C       | 1 minute   |           |
| Cooling down         | 40 °C       | 20 seconds | 1 cycle   |

SYBR® Green I is a dsDNA-intercalating dye that binds the minor groove of dsDNA. Consequently, as PCR proceeds and amplification of target sequence is ongoing, every new copy of dsDNA produced is bound by the dye during the extension step and fluorescence intensity increases. Fluorescence intensity signal is therefore proportional to the amount of dsDNA in the reaction (Arya et al. 2005). Reaction components and qPCR program are presented in tables 3.15 and 3.16 respectively.

**Table 3.15** SYBR® Green qPCR components

| SYBR® Green Assay                |             |        |
|----------------------------------|-------------|--------|
| Reaction components              | Volume (µL) | Conc.  |
| Template DNA (cDNA)              | 2.5         | 50 ng  |
| Forward primer                   | 1           | 0.5 µM |
| Reverse primer                   | 1           | 0.5 µM |
| 2x SYBR MasterMix                | 10          | 1x     |
| Nuclease-free ddH <sub>2</sub> O | 5.5         |        |
| Total Mix/reaction               | 20          |        |

**Table 3.16** SYBR® Green qPCR program

| Program Name   | Temperature | Time       |           |
|----------------|-------------|------------|-----------|
| Pre-incubation | 95 °C       | 5 minutes  | 1 cycle   |
| Amplification  | 95 °C       | 10 seconds |           |
|                | 60 °C       | 10 seconds | 45 cycles |
|                | 72 °C       | 10 seconds |           |
| Melting curve  | 95 °C       | 5 seconds  |           |
|                | 65 °C       | 1 minute   | 1 cycle   |
|                | 97 °C       | -          |           |
| Cooling        | 40 °C       | 30 seconds | 1 cycle   |

Data were normalised using Ct (Cp) values of the endogenous control. ATP synthase subunit-  $\beta$  (*Atp5b*) was used as endogenous control for TaqMan assay while *actin* was used as the endogenous control of SYBR® Green assay. The LightCycler® 480 software 1.5.1 was used to run absolute quantification/2<sup>nd</sup> derivative max and advanced relative quantification analysis (which automatically calculates fold change in expression based on the  $2^{-\Delta\Delta C_T}$  method by Livak and Schmittgen, 2001 for both assays. In addition, Melt Curve genotyping analysis was run for SYBR® Green assay.

### 3.2.4 Small interfering (siRNA)-mediated gene silencing

siRNAs are short (approximately 21-25 nucleotides), non-coding double-stranded RNAs (dsRNA) that facilitate gene silencing through complementary targeting of the mRNA to be degraded. On the 3' end of each strand (sense/passenger and antisense/guide strand), siRNAs have an overhang of 2 nucleotides (Gavrilov and Saltzman 2012). Because siRNAs are directly introduced into cells, the dicer (which cuts long pieces of dsRNA into the siRNAs) mechanics have already been by-passed

(Whitehead et al. 2009). Once in the cell's cytoplasm, siRNAs get integrated into a multi-protein complex called RNA-induced silencing complex (RISC) having argonaute-2 as the main protein that executes the process of gene silencing (Hammond et al. 2001). Argonaute-2 unwinds the dsRNA, with the passenger strand being cleaved off leaving the guide strand (i.e., strand with more stability at 5'-end) in the complex, which is now the activated RISC (Matranga et al. 2005). The antisense strand of the siRNA now guides and positions the RISC complex on the target mRNA and with the aid of argonaute-2, the target mRNA is degraded resulting in gene silencing (Ameres et al. 2007). The active RISC-siRNA complex is then recycled for subsequent mRNA degradation further propagating the process of gene silencing (Whitehead et al. 2009).

In this study, ON-TARGETplus SMART pool siRNAs were used. These siRNAs combine four different siRNA sequences per gene (Table 3.8) to reduce off target effects. siRNAs targeted against mouse PDGFR $\alpha$  and PDGFR $\beta$  were used while the non-targeting negative control pool served as control siRNA. A 20 $\mu$ M stock solution of these siRNAs were prepared from a lyophilized vial of 5nM by reconstituting in 250 $\mu$ l of 1x siRNA buffer (diluted from a 5x stock solution with RNase free water). The 20 $\mu$ M stock solution of siRNAs were aliquoted (in volumes of single use to avoid freeze and thaw degradation) and stored at -20°C until use.

BV-2 microglial cells were seeded in 12-well culture plates as previously described above (section 3.2.1.3). Transfection was done as previously described by Rosner et al., 2010. Briefly, one hour before transfection, cells were washed with 0.5ml of pre-warmed 1x DPBS, thereafter, 900 $\mu$ l of Opti-MEM I reduced serum medium was added and re-incubated. siRNA/lipid complexes were prepared by combining 3 $\mu$ l of lipofectamine 3000 transfection reagent with 100 $\mu$ l of Opti-MEM I medium for 5 minutes at room temperature. 2.5 $\mu$ l of siRNA duplex was then added into the mixture to a final concentration of 50nM. The siRNA/lipid mixture was then incubated at room temperature for 20 minutes after which the combined mixture was added to cells in a dropwise manner and incubated at 37°C at 5% CO<sub>2</sub>. After 6 hours of transfection, medium was changed to transfection medium (medium without antibiotics) and transfection continued for a total of 48 hours. In one experiment, medium was changed to fresh transfection medium and 48 hours post transfection, cells were treated with 100ng/ml LPS for 6 hours (supernatant used for ELISA while cells were lysed for RNA isolation as described in section 3.2.3.1). In separate experiment, medium was

changed to fresh serum-free transfection medium and 48 hours post transfection, cells were treated with 50ng/ml PDGF-BB for 3 hours (gene expression) or 24 hours (protein expression - ELISA).

### **3.2.5 Protein analysis**

#### **3.2.5.1 Protein isolation and quantification**

BV-2 microglial cells were seeded in 6-well culture plates (section 3.2.1.3) and treated in a time kinetic study as described above (section 3.2.1.4). At the termination of experiment, cells were washed once with ice-cold 1x DPBS and lysed in 50µl ice-cold RIPA buffer supplemented with protease inhibitor cocktail and phosphatase inhibitor (for phospho-proteins). Following an incubation period of 30 minutes on ice, samples were transferred into chilled 1.5ml PCR tubes and centrifuged (centrifuge previously cooled to 4°C) at maximum RCF at 4°C for 15 minutes. Supernatant containing protein was carefully transferred into chilled tubes and stored at -80°C until further use. All steps were performed on ice to avoid protein degradation.

Protein concentration present in samples were determined using the Pierce™ Bicinchoninic Acid (BCA) protein assay kit according to the manufacturer's protocol. The principle of BCA assay is based on the reduction of  $\text{Cu}^{2+}$  to  $\text{Cu}^+$  by proteins in an alkaline medium which results in a purple colour formation from green by BCA. This purple colouration is a result of chelation of two molecules of BCA with one molecule of cuprous ion. Thus, the colour change is proportional to protein concentration.

Briefly, Bovine Serum Albumin (BSA) protein standard, provided in the kit at a concentration of 2mg/ml was serially diluted with water to 1.5, 1.0, 0.75, 0.5, 0.25, 0.125 and 0.025mg/ml while the protein samples were diluted 1:20 also with water. 25µl of each standard or unknown samples were then pipetted in triplicates into a 96-well culture plate after which 200µl of working reagent (50 parts of reagent A mixed with 1 part of reagent B) was added to each well containing standard and samples. The plate was mixed thoroughly on a plate shaker for 30 seconds and incubated at 37°C for 30 minutes. The plate was allowed to cool to room temperature and absorbance measured at 570nm with Tecan Infinite® F200 pro microplate reader. Absorbance values of the standard (BSA) were plotted against known concentrations to generate a standard curve from where concentrations of unknown samples were interpolated.

### 3.2.5.2 Western Blot

Protein samples were denatured at 95°C for 5 minutes following the addition of 1x Laemmli sample buffer (diluted from 4x with  $\beta$ -mercaptoethanol) to the samples. 20 $\mu$ g of protein were separated using 8 or 15% (depending on the molecular size of analysed protein) SDS-PAGE with PageRuler™ (Plus) Prestained Protein Ladder at 100V for 2 hours. Subsequently, proteins were transferred onto a 0.45 $\mu$ m nitrocellulose membrane at 70V for 1-2 hours. Following successful protein transfer, membranes were blocked in membrane blocking buffer for 1 hour to prevent non-specific binding. Thereafter, membranes were washed in 1x TBS-T buffer for 15 minutes at three intervals of 5 minutes each. Subsequently, membranes were incubated with diluted primary antibody at 4°C overnight on a roller. All primary antibodies used here were diluted in antibody solution for WB except for PDGFB and  $\beta$ -actin antibody that were diluted in membrane blocking buffer. The following day, membranes were washed in 1x TBST buffer as previously described, thereafter incubated with horseradish peroxidase (HRP)-conjugated secondary antibodies (against the respective primary antibody) for 2 hours at room temperature on a roller. Membranes were developed with SignalFire™ Elite ECL Reagent and protein bands visualised and imaged with the MultiImage II system.

For detection of phosphorylated and total proteins, the phosphorylated proteins were probed first after which membranes were stripped off the phospho-protein using mild stripping in a series of steps. First, membranes were incubated in stripping buffer twice for 10 minutes each, discarding the buffer each time. Second, membranes were washed in 1x PBS twice for 10 minutes each and last, membranes were washed in 1x TBS-T twice for 5 minutes each. Efficiency of stripping was checked by incubating the membrane in the chemiluminescent detection (SignalFire™ Elite ECL) reagent and visualisation with the imager. Following successful stripping, membranes were rinsed severally with stripping buffer before blocking and continuation with the remaining steps for incubation in primary antibody for the total protein. Blocking, washing and stripping steps were all done at room temperature on a see-saw rocker to ensure even distribution of solutions. Band intensities were quantified using Image J 1.47 software.

### 3.2.5.3 Immunocytochemistry

BV-2 microglial cells were seeded on cover slips in 6-well plates at a density of 1x10<sup>5</sup> cells/well in 2ml media and allowed to attach overnight. Cells were treated with 50 and



100ng/ml LPS for 24 hours. At the termination of experiment, medium was aspirated, cells washed with 1x PBS, thereafter fixed with 4% HistoFix for 10 minutes. Subsequently, cells were washed with 1x PBS for 15 minutes at 5 minutes interval discarding the PBS each time. Following the third wash, cells were incubated in blocking buffer for 30 minutes followed by washing steps as previous. Thereafter, cells were incubated in primary antibody (diluted in antibody solution for ICC) at 4°C overnight on a see-saw rocker. On the second day, washing steps were repeated as previous, and cells were further incubated in secondary antibody (diluted in 1x PBS) for 30 minutes. From secondary antibody incubation onwards, cells were protected from light. This step was followed by washing steps as previous. Thereafter, cell nuclei were stained with 0.1µg/ml DAPI (diluted in 1x PBS) for 5 minutes, washing steps were again repeated as previous and cover slips mounted on microscope glass slides with Dako fluorescence mounting medium. Fixation, washing, blocking, secondary incubation, and nuclei staining steps were all done at room temperature on a see-saw rocker to ensure even distribution of solutions. Cover slips were allowed to dry and fluorescence photomicrographs were taken with an AxioImager.M2 plus ApoTome2 microscope.

#### **3.2.5.4 Enzyme-Linked Immunosorbent Assay (ELISA)**

BV-2 microglial cells were seeded in 12-well culture plates for siRNA experiments as described above. At the termination of experiments, culture medium was collected from treated cells into 2 ml reaction tubes, centrifuged (centrifuge previously cooled to 4°C) at 1500 rpm at 4°C for 10 minutes. Supernatants were carefully transferred into chilled 2ml reaction tubes and stored at -80°C until used for measurement of CCL2 protein with ELISA kit according to manufacturer's instruction.

Capture antibody was reconstituted in 0.5ml 1x DPBS, detection antibody in 1ml reagent diluent, and standard in 0.5ml reagent diluent which were all aliquoted in volumes of single use and stored at -20°C. Thereafter, each well of a 96-well ELISA microplate was coated with reconstituted 100µl capture antibody (further diluted in 1x DPBS to the working concentration of 200ng/ml), plate was sealed with an adhesive strip and incubated overnight at room temperature. Following day, wells were aspirated and washed with 400µl wash buffer for a total of three washes ensuring complete removal of liquid by inverting the plate and blotting against clean paper towels. Subsequently, plates were blocked by adding 300µl reagent diluent to each

well and incubated at room temperature for 1-2 hours. During this time period, standard and samples were prepared accordingly. A two-fold serial dilution (diluted in reagent diluent) of the reconstituted standard was prepared from a starting concentration of 250pg/ml to the lowest concentration of 3.91pg/ml (a 7-point standard curve). Samples were equally diluted in reagent diluent from 1:50 to 1:100 dilution. After the indicated period of plate blocking, aspiration/wash steps were repeated as previously mentioned. Thereafter, 100µl of each standard and samples were pipetted to each well in duplicates, covered with an adhesive strip and incubated for 2 hours at room temperature. Following standard/sample addition, aspiration/wash steps were repeated as previous and 100µl of reconstituted detection antibody (further diluted in reagent diluent to the working concentration of 50ng/ml) was added to each well, plate was covered with a new adhesive strip and incubated for another 2 hours at room temperature. Aspiration/wash steps were repeated followed by addition of 100µl of Streptavidin-HRP (40-fold dilution in reagent diluent) to each well, plate was covered and incubated for 20 minutes at room temperature avoiding direct light contact. Again, aspiration/wash steps were repeated followed by addition of 100µl of substrate solution (1:1 mixture of A and B) to each well, plate was covered and incubated for another 20 minutes at room temperature while again avoiding direct light contact (green colouration visible). Reaction was terminated by adding 50µl of stop solution (2N H<sub>2</sub>SO<sub>4</sub>) to each well (colour change with visible yellow colour in sight). The plate was gently mixed and resulting colour change was read at a wavelength of 450nm with the Tecan Infinite® F200 pro microplate reader. However, to correct for optical imperfections in the plate, readings were also taken at 540nm and values from these readings were subtracted from readings at 450nm. Absorbance values of the standards were plotted against their known concentrations generating a standard curve from where concentrations of samples were interpolated.

### **3.2.6 Microglia functional assays**

#### **3.2.6.1 Morphology assay**

BV-2 microglial cells were seeded on cover slips in 6-well plates at a density of 1x10<sup>5</sup> cells/well in 2ml media and allowed to attach overnight. Cells were treated with 50ng/ml recombinant PDGF ligands and vehicle control for 3 hours. At the termination of experiment, cells were washed once with 1x PBS for 5 minutes. Thereafter, cells were fixed with 4% HistoFix, washed thrice with 1x PBS for 5 minutes each and

permeabilized in PBS containing 0.1%v/v Triton X-100 for 5 minutes. Previous washing steps were repeated. Next, filamentous actin (F-actin) was fluorescently labeled with 1 $\mu$ g/ml phalloidin-TRITC (diluted in 1x PBS) for one hour under exclusion from light followed by washing steps as previously described. Cell nuclei were stained with 0.1 $\mu$ g/ml DAPI (diluted in 1x PBS) for 10 minutes in the dark, and cover slips mounted on microscope glass slides with Dako fluorescence mounting medium. All steps from the termination of experiments to nuclei staining were done on a see-saw rocker (to ensure even distribution of solutions) at room temperature. Cover slips were allowed to dry and photomicrographs were taken with an AxioImager.M2 plus ApoTome2 microscope.

### **3.2.6.2 Migration (Wound healing) assay**

BV-2 microglial cells were seeded at a density of 1x10<sup>6</sup> cells/well in 2ml media and incubated until 100% confluent with daily medium renewal and finally changing to serum-free medium prior to the experimental day. On experimental day, cells were linearly scratched with a sterile 100 $\mu$ l pipette tip, afterwards the medium was aspirated and cells washed twice with medium to remove floating cells. At this point, time '0' hour pictures were taken at pre-marked areas after which medium was replaced with that containing vehicle and 50ng/ml recombinant PDGF ligands. Migration into the open scar was monitored with photomicrographs taken at 3 and 6 hours with an AxioVert.A1 inverted microscope (Nikon, Tokyo, Japan). The unpopulated area at these time points were measured using the MRI wound healing tool of ImageJ software. The values of the scratch area at the different time points (3 and 6 hours) were subtracted from the scratch area at time '0' to get the repopulated area (after 3 and 6 hours). Results are presented as percentage area coverage of scratch area at time '0' hour to the repopulated area at time '6' hours.

### **3.2.6.3 Phagocytosis assay**

Microglia phagocytic capacity were determined using two different established methods, the latex beads method (to mimic exogenous particles) and the apoptotic material method (to mimic apoptotic debris). Polystyrene latex beads and 661W photoreceptor cell debris were used as substrates for microglia to engulf. BV-2 microglial cells were seeded in 6-well culture plates as described above (section 3.2.1.3). While cells were seeded directly into culture plates for the first assay, they were seeded on cover slips for the second assay.

**Polystyrene latex beads:** Cells were pre-treated for 2 hours with 50ng/ml recombinant PDGF ligands and vehicle control before 4 $\mu$ l polystyrene latex bead solution was added to the wells. Cells were further incubated for a period of 3 hours. At the termination of the experiment, five independent photomicrographs were taken per well using an AxioVert.A1 inverted microscope. The average number of total cells per field and the average number of cells which had phagocytosed 10 or more latex beads were calculated. Phagocytic capacity was then determined in percentage as the average number of cells which had phagocytosed 10 or more latex beads of the average number of total cells per field.

**Apoptotic material:** Apoptosis was induced in 661W photoreceptor cells by serum deprivation for two to three weeks. Dead cells were harvested into 50ml falcon tubes, centrifuged at 10,000 RCF for 10 minutes to collect cell pellet which was either stored at -80°C until use or immediately labelled with the fluorescent lipophilic dye, CellTracker™ CM-Dil. 400 $\mu$ l-stained apoptotic 661W cell suspension were added for 6 hours to cells pre-treated for 3 hours with 50ng/ml recombinant PDGF ligands and vehicle control. At the termination of experiment, cells were thoroughly washed with 1x PBS to get rid of the remaining extracellular 661W debris. Cells were fixed with 4% HistoFix. Thereafter, nuclei were stained with 0.1 $\mu$ g/ml DAPI (diluted in 1x PBS) for 10 minutes in the dark at room temperature, and cover slips mounted on microscope glass slides with Dako fluorescence mounting medium. Cover slips were allowed to dry and fluorescence micrographs were taken with an AxioImager.M2 plus ApoTome2 microscope ensuring constant exposure times for all groups. The ratio of phagocytosed photoreceptor debris (background-corrected red signal) relative to the total microglial cell number (background corrected DAPI signal) was determined using Image J software and values expressed as percentages.

#### **3.2.6.4 Cellular Reactive Oxygen Species (ROS) generation assay**

The 2',7'-dichlorofluorescein diacetate (DCFDA)-cellular ROS detection assay kit was used to measure intracellular ROS production. Hydroxyl, peroxy and other ROS activity within the cell is measured by the cell-permeable fluorogenic dye DCFDA which is able to diffuse into the cell to get acetylated by cellular esterases into a non-fluorescent compound. Intracellular ROS then oxidises this non-fluorescent compound into a highly fluorescent compound, 2',7'- dichlorofluorescein (DCF), which is then

detected at a maximum excitation and emission spectra of 495nm and 529nm respectively.

BV-2 microglial cells were seeded in phenol free media at a density of  $2.5 \times 10^4$  cells/well in 100 $\mu$ l media in black, clear-bottom(ed) 96-well culture plates and allowed to attach overnight. Phenol-free media was used in order to reduce background fluorescence. Appropriate volumes needed for the following solutions were freshly prepared; 1x buffer solution prepared from a 10x buffer with double-distilled water, 20 $\mu$ M DCFDA prepared from a 20mM stock with 1x buffer solution, 1x supplemented buffer prepared by adding 2ml FBS (not included in the kit) to 18ml of 1x buffer, 50 $\mu$ M Tert-Butyl Hydrogen Peroxide (TBHP) prepared from a 55mM stock with 1x supplemented buffer.

Cells were stained with 100 $\mu$ l of 20 $\mu$ M DCFDA at 37°C for 45 minutes followed by washing with 1x buffer and treatment in separate wells with 100 $\mu$ l of: 50ng/ml recombinant PDGF ligands, vehicle control, 50 $\mu$ M TBHP (positive control) and 1x supplemented buffer (control for TBHP) for 3 hours at 37°C. Blank wells with non-stained cells were included to determine background fluorescence. Intracellular production of ROS was then measured by fluorescence detection of DCF in a microplate reader - Tecan Infinite® F200 pro reader at an excitation and emission wavelength of 485nm and 535nm respectively. Background values were subsequently subtracted from all measurements.

### **3.2.6.5 661W photoreceptor apoptosis assay**

The Caspase-Glo® 3/7 assay was used to measure caspase activity (an indication of apoptotic cell death) in 661W cells treated with MCM in order to investigate microglia neurotoxicity. The assay provides a pro-luminescent caspase-3/7 substrate which contains the tetrapeptide sequence, DEVD, combined with luciferase and a cell-lysis agent. When the Caspase-Glo® 3/7 reagent is directly added to assay wells, this causes cell lysis followed by caspase cleavage of the DEVD substrate, and subsequently, the generation of luminescence. The luminescence amount is therefore proportional to the amount of caspase activity within the sample.

661W cells were seeded at a density of 10,000 cells/well in 100 $\mu$ l of serum-free media in white-walled 96-well luminometer culture plates and allowed to attach overnight. Following day, media was aspirated and cells were re-incubated for 48 hours either in their own serum-free medium or with serum-free microglia conditioned medium as

described above (section 3.2.1.4). The Caspase-Glo<sup>®</sup> 3/7 reagent was then prepared by adding all of the Caspase-Glo<sup>®</sup> buffer to the Caspase-Glo<sup>®</sup> 3/7 substrate (both provided in the kit) ensuring complete mixture. 100µl of the Caspase-Glo<sup>®</sup> 3/7 reagent was then added to each well and incubated at room temperature for 1 hour. Included in the experimental set-up, were blank reactions (vehicle in culture medium without cells plus Caspase-Glo<sup>®</sup> 3/7 reagent), to determine background luminescence associated with the Caspase-Glo<sup>®</sup> 3/7 reagent and the cell culture system and negative control reactions (vehicle-treated cells plus Caspase-Glo<sup>®</sup> 3/7 reagent), to determine basal caspase activity of the 661W cells. Following incubation with the Caspase-Glo<sup>®</sup> 3/7 reagent, the generated luminescence was measured using the Tecan Infinite<sup>®</sup> F200 pro microplate reader. Background luminescence values were subtracted from all experimental values and the amount of luminescence expressed as Relative Light Units (RLU) which is proportional to the amount of caspase activity (apoptotic cell death) in 661W cells.

### **3.2.7 Statistical analysis**

Statistical analysis was performed using GraphPad Prism version 7 (GraphPad Software Inc., San Diego, CA). Depending on the experimental set up, statistical significance was determined using either unpaired Student's T-test (for two groups) or one-way ANOVA (for multiple group) followed by Dunnet's, Tukey's, or Sidak's multiple comparisons test and  $p \leq 0.05$  was considered statistically significant. Data are expressed as mean  $\pm$  standard deviation (SD) unless otherwise stated.

## CHAPTER FOUR: RESULTS

## 4.1 Expression of PDGFs and their receptors in murine microglial cells

Expression of PDGF ligands and their receptors were studied in BV-2 microglial cells first using qPCR (Fig. 4.1). In LPS-activated BV-2 microglial cells, where activation was confirmed by upregulation of *Tnfa* gene (Fig. 4.1A), mRNA expression levels of *Pdgfb* (Fig. 4.1E) and *Pdgfr $\beta$*  (Fig. 4.1C) were significantly upregulated while expression of *Pdgfc* (Fig. 4.1F) was significantly downregulated. mRNA levels of *Pdgfa* (Fig. 4.1D) and *Pdgfra* (Fig. 4.1B) were not significantly altered while expression of *Pdgfd* could not be detected.

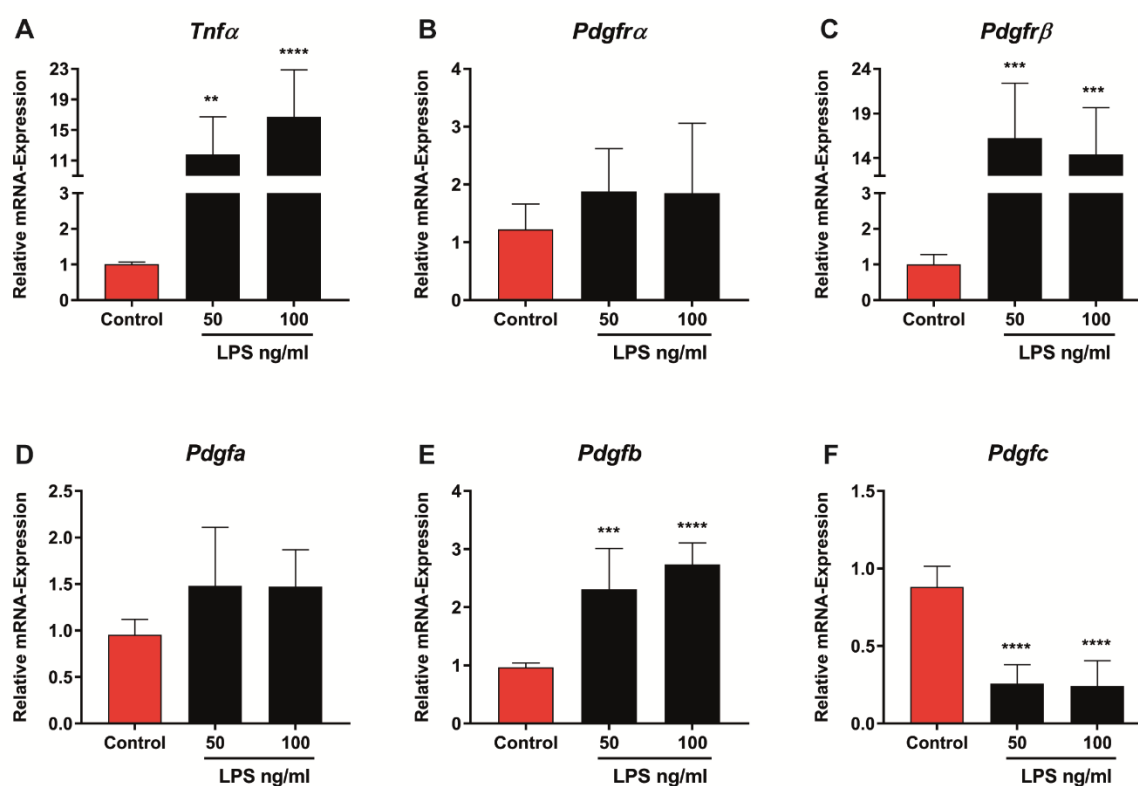
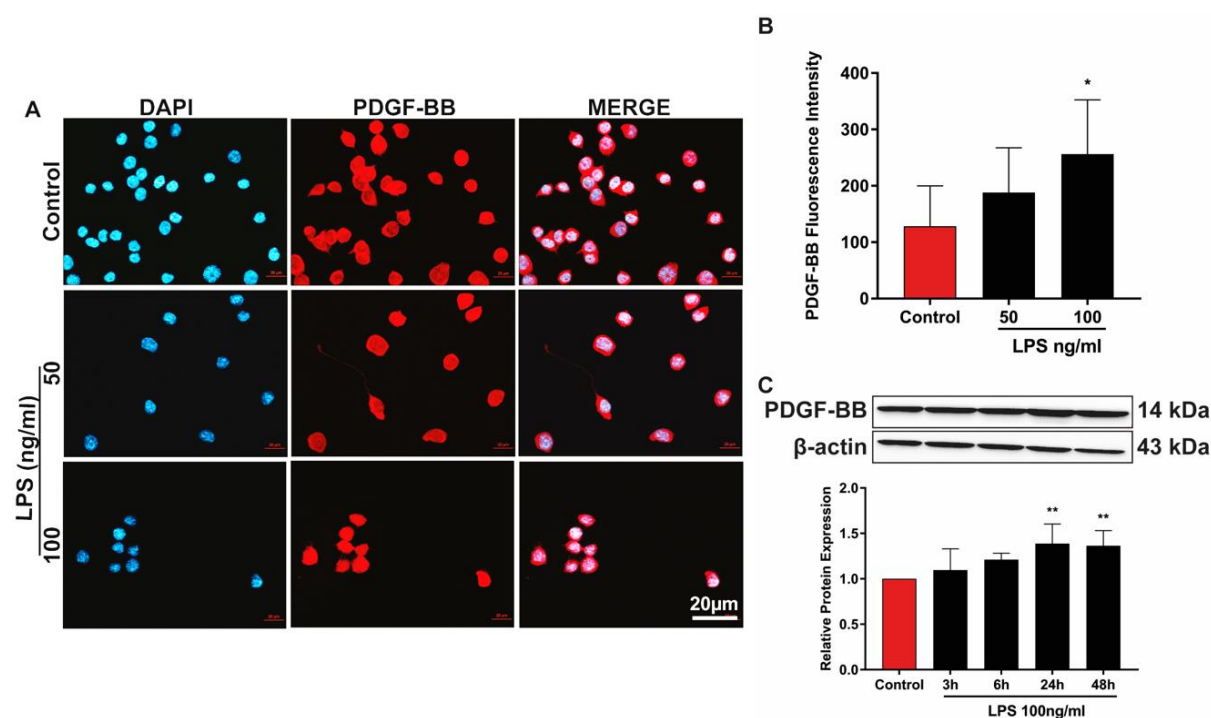

**Figure 4.1** Expression of PDGF ligands and their receptors in BV-2 microglial cells.

Quantitative PCR data of gene expression levels of *Tnfa* (A), *Pdgfra* (B), *Pdgfr $\beta$*  (C), *Pdgfa* (D), *Pdgfb* (E) and *Pdgfc* (F). Data are presented as mean  $\pm$  SD of three independent experiments measured in duplicates (N=6). \*\* $p \leq 0.01$ , \*\*\* $p \leq 0.001$ , \*\*\*\* $p \leq 0.0001$  compared to control (PBS), one-way AVOVA with Tukey's multiple comparison test.

To confirm whether increased gene expression levels of *Pdgfb* (Fig. 4.1E) and *Pdgfr $\beta$*  (Fig. 4.1C) translated into increased protein levels, western blot analysis of BV-2 microglial cells exposed to LPS in a time kinetic study (3 - 48hrs) and immunostaining

of cells exposed to LPS for 24 hours was done. Fluorescence immunostaining of both PDGF-BB (observed throughout the whole cell, cytoplasm and nucleus) (Fig. 4.2A) and PDGFR $\beta$  (observed as punctate staining in the cytoplasm and predominantly in the perinuclear region of the cells) (Fig. 4.3A) showed significant increased expression with 100ng/ml LPS after 24 hours (Fig. 4.2B and 4.3B) while WB analysis of both PDGF-BB (Fig. 4.2C) and phospho-PDGFR $\beta$  (Fig. 4.3C) proteins showed significant increased expression at 24 and 48 hours respectively.



**Figure 4.2 LPS induced protein expression of PDGF-BB in BV-2 microglial cells**

**(A)** Representative immunostaining of PDGF-BB protein (Red), nuclei stained with DAPI (blue) and **(B)** Quantification of fluorescence intensity from six immunostainings per group done in duplicates of three experiments,  $*p \leq 0.05$  compared to control (PBS), one-way AVOVA with Tukey's multiple comparison test. **(C)** Representative western blot of PDGF-BB protein and densitometric analysis from five immunoblots,  $**p \leq 0.01$  compared to control (PBS), one-way AVOVA with Dunnett's multiple comparison test. All data are presented as mean  $\pm$  SD.



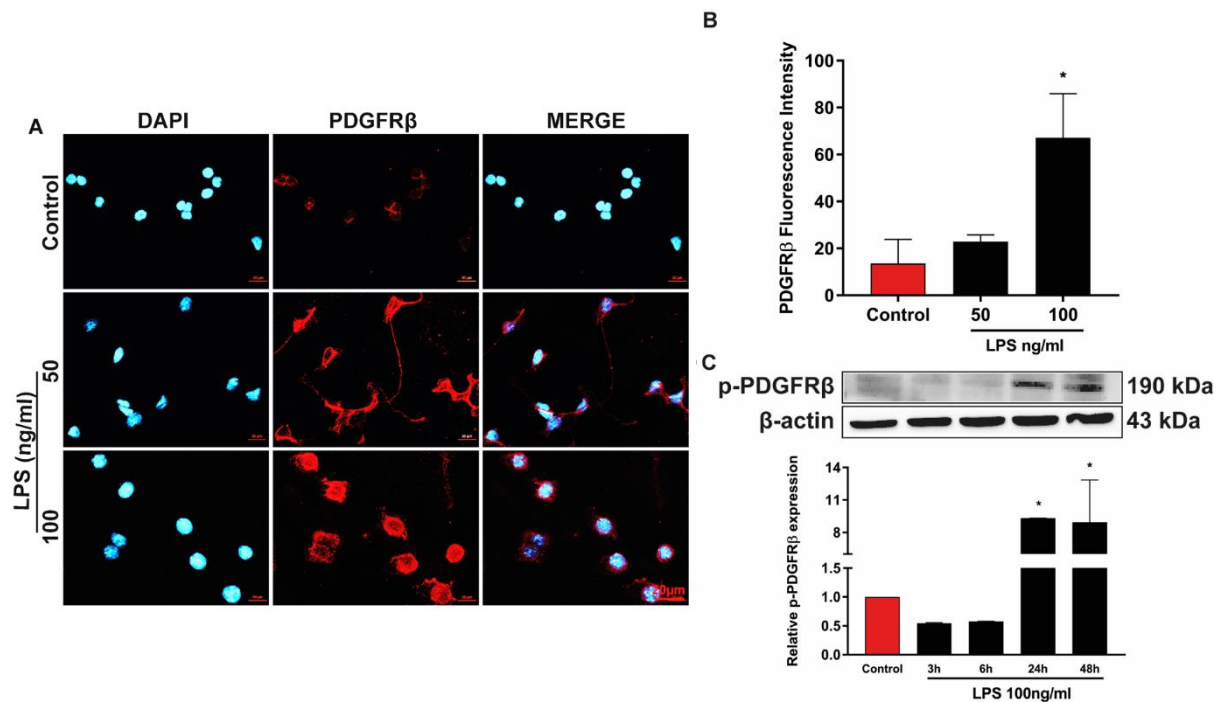

**Figure 4.3 LPS induced PDGFR $\beta$  and p-PDGFR $\beta$  expression in BV-2 microglial cells.**

**(A)** Representative immunostaining of PDGFR $\beta$  protein (Red), nuclei stained with DAPI (blue) and **(B)** Quantification of fluorescence intensity from two immunostainings,  $*p \leq 0.05$  compared to control (PBS), One-way ANOVA with Tukey's multiple comparison test. **(C)** Representative western blot of phosphorylated PDGFR $\beta$  protein and densitometric analysis from two immunoblots,  $*p \leq 0.05$  compared to control (PBS), one-way ANOVA with Dunnett's multiple comparison test. All data are presented as mean  $\pm$  SD.

## 4.2 Effect of PDGF on microglia functional properties

BV-2 microglial cells were treated with human recombinant PDGF ligands and their effects on microglia functional properties: morphology, migration, phagocytosis, inflammatory response, ROS release and neurotoxicity were studied.

### 4.2.1 PDGF induced an amoeboid-like phenotype in microglia

Treatment of BV-2 microglial cells with 50ng/ml recombinant human PDGF ligands for 3 hours induced an amoeboid-like phenotype in microglia (Fig. 4.4A). Following exposure to PDGF ligands, microglial cells showed clear morphological differences in all the treatment groups compared to the control group. In control-treated group, microglial cells displayed a ramified morphology characterised by elongated processes while in all of the treatment groups, all cells were induced towards an amoeboid morphology with large cell bodies indicative of an activated state (Fig. 4.4A). The induced activation of BV-2 microglial cells by PDGF was accompanied by

concomitant decrease in mRNA levels of the microglia homeostatic gene, *P2ry12* (P2Y purinoceptor-12) (Fig. 4.4B). *P2ry12* gene is one of the ‘sensible’ genes used by microglia processes to sense changes within their environment and facilitate tissue homeostasis (Haynes et al. 2006; Hickman et al. 2013; Fourgeaud et al. 2016) thus a change in microglia homeostasis results in downregulation of these genes (Hickman et al. 2013). Results show that all the PDGF ligands significantly decreased the expression of the *P2ry12* gene (Fig. 4.4B).

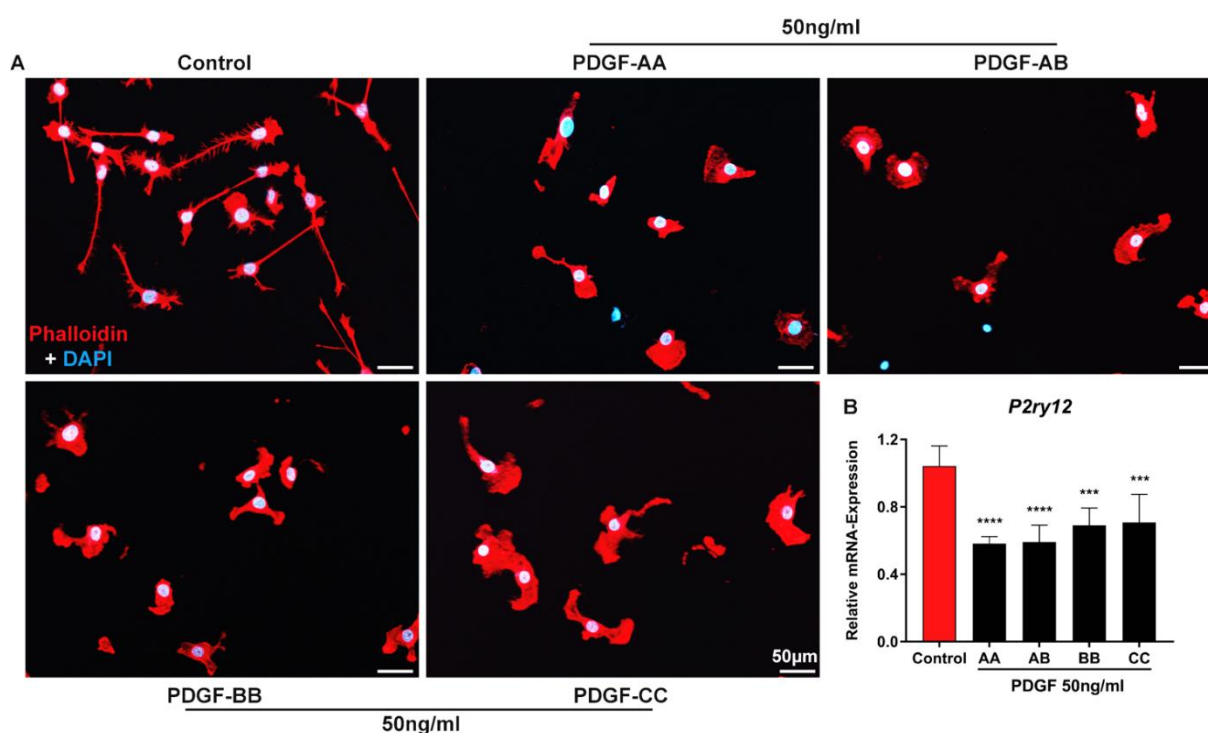

**Figure 4.4 PDGF induced an amoeboid-like phenotype in BV-2 microglial cells.**

(A) Representative images of phalloidin-TRITC stained BV-2 microglial cells treated with recombinant PDGF ligands. (B) Quantitative PCR data of expression level of the microglia homeostatic gene, *P2ry12* in the presence of PDGF. Data are presented as mean  $\pm$  SD of at least two independent experiments measured in duplicates (N=4-8). \*\*\* $p \leq 0.001$ , \*\*\*\* $p \leq 0.0001$  compared control, one-way ANOVA with Dunnett’s multiple comparison test. Control - 0.1% BSA in DPBS.

#### 4.2.2 Effect of PDGF on microglial cell migration

To investigate the effect of PDGF on microglial cell migration, a wound healing (scratch) assay was performed where a ‘wound’ in form of a scratch was introduced onto a confluent layer of BV-2 microglial cells and migration into the open scar was monitored following treatment with 50ng/ml recombinant human PDGF ligands over

the indicated time period. As shown in figure 4.5A and B, PDGF ligands did not significantly affect BV-2 microglial cell migration compared to control after 6 hours of ligand treatment. However, the pro-migratory related genes, *Ccl3* and *Ccl5* (Fig. 4.5C and D) including *Ccl2* (Fig. 4.7A) were significantly upregulated after 3 hours of ligand treatment.

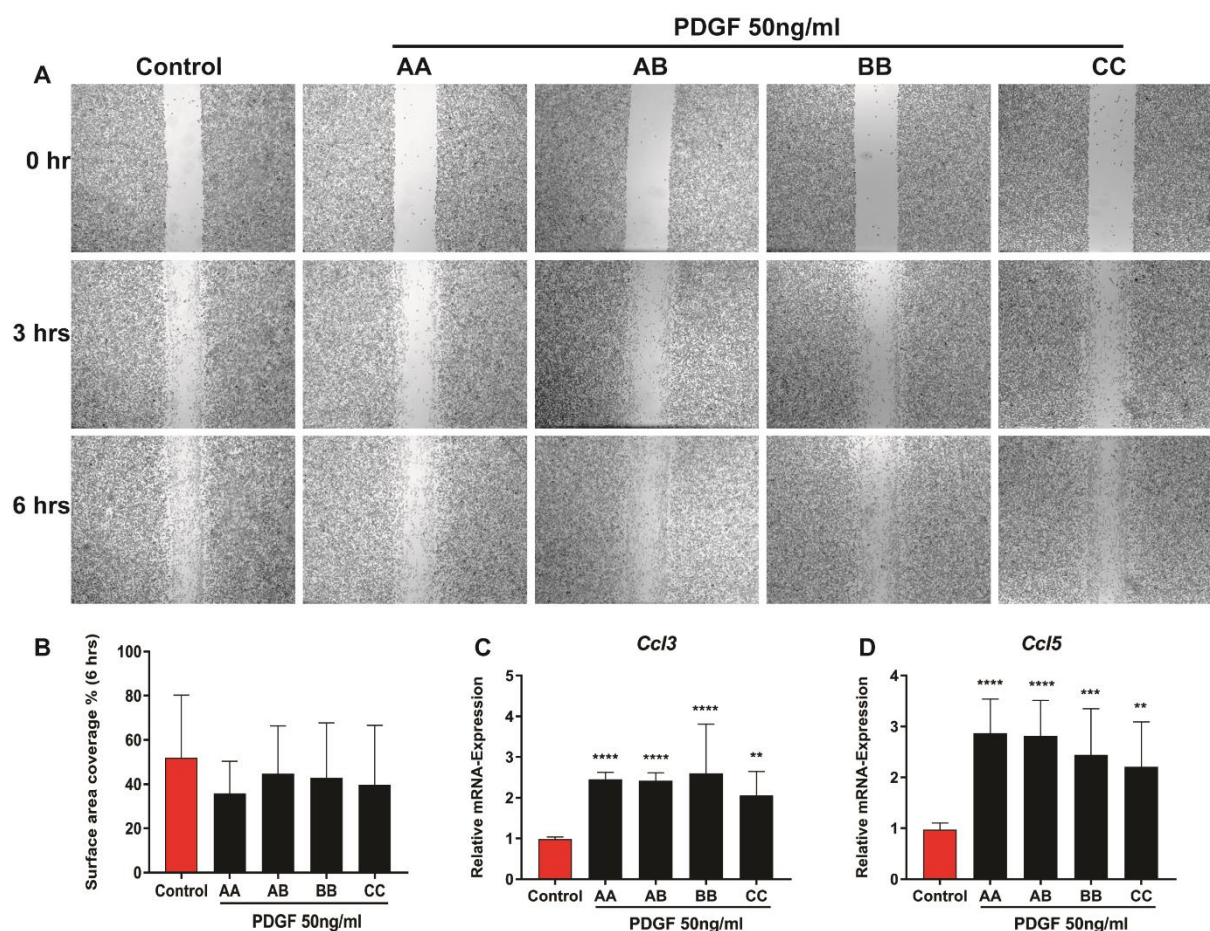

**Figure 4.5 Effect of PDGF on BV-2 microglial cell migration and pro-migratory genes.**

**(A)** Representative micrograph of scratch migration assay in BV-2 microglial cells treated with recombinant PDGF ligands. Scale bar-200 $\mu$ m **(B)** Quantification of surface area coverage from six micrographs taken per group from three experiments in duplicates (N=6). No significant differences seen between treatment and control group. **(C and D)** Quantitative PCR data of expression levels of pro-migratory genes, *Ccl3* and *Ccl5* in the presence of PDGF (N=7-11 of at least three independent experiments). All data are presented as mean  $\pm$  SD, \*\* $p \leq 0.01$ , \*\*\* $p \leq 0.001$ , \*\*\*\* $p \leq 0.0001$  compared to control, one-way ANOVA with Dunnett's multiple comparison test. Control - 0.1% BSA in DPBS.

### 4.2.3 Effect of PDGF on microglia phagocytic capacity

Microglia are characterised by their ability to phagocytose extracellular protein aggregates, pathogens, and apoptotic cell debris (R. Fu et al. 2014) as part of their housekeeping functions. Thus, to mimic exogenous particles and apoptotic cell debris, polystyrene micro particles latex beads and CM-Dil-stained apoptotic 661W photoreceptor fragments were used as substrates for BV-2 microglial cells to engulf while the phagocytic capacity following 3 hours of treatment with 50ng/ml recombinant human PDGF was assessed. In the latex bead assay, treatment with the PDGFs did not significantly affect phagocytic capacity of BV-2 microglial cells (Fig. 4.6A and B). Similar results were also observed in the cellular debris assay (Appendix fig. 3A and B). In addition, treatment with 50ng/ml PDGF-BB did not significantly affect the expression of phagocytosis related genes, cluster of differentiation 36 (*Cd36*) (Fig. 4.6C), triggering receptor expressed on myeloid cells 2 (*Trem2*) (Fig. 4.6D), and the scavenger receptors, macrophage scavenger receptor 1 (*Msr1*) (Fig. 4.6E), and scavenger receptor class B member 1 (*Scarb1*) (Fig. 4.6F).



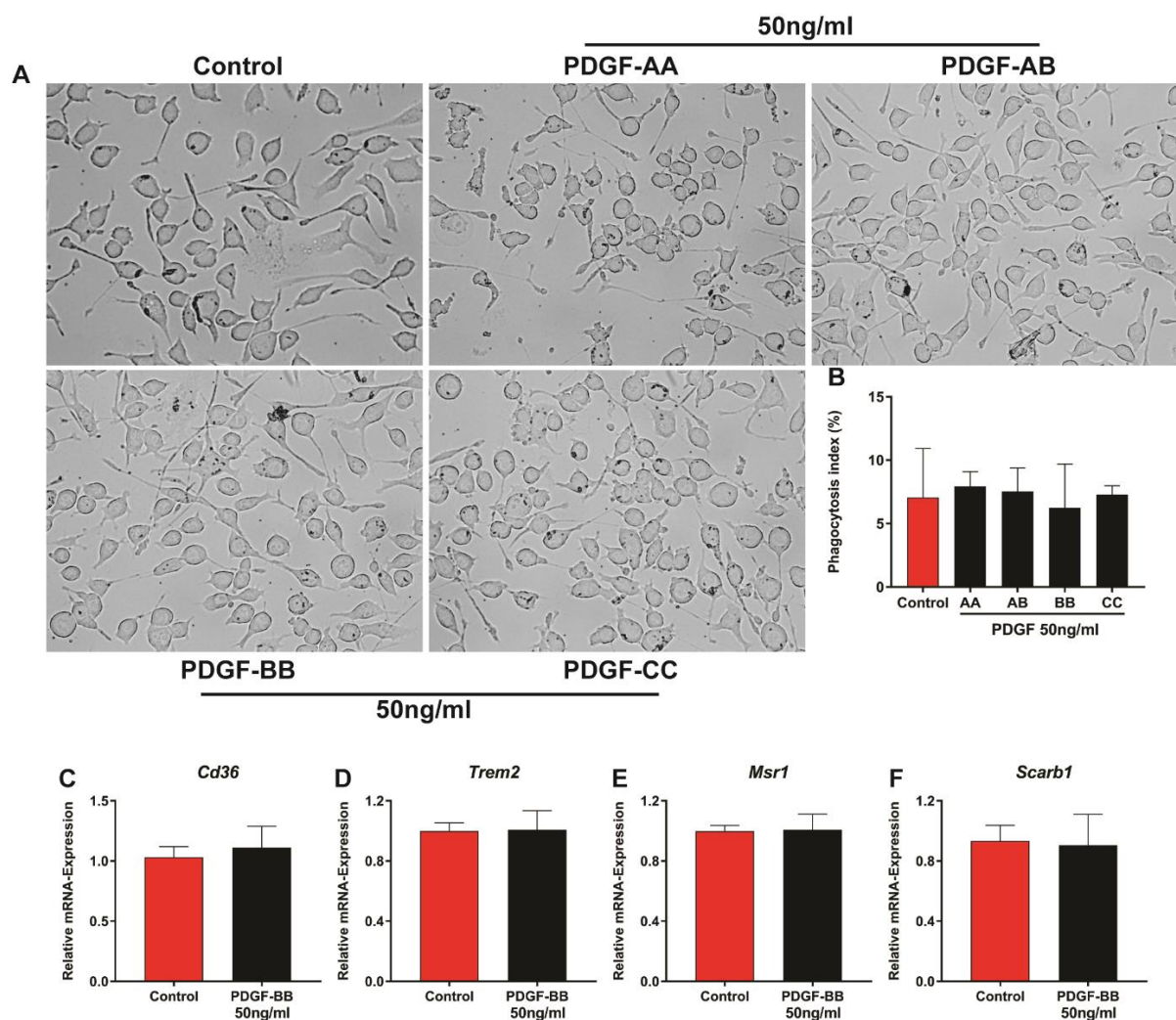

**Figure 4.6 Effect of PDGF on BV-2 microglia phagocytic capacity.**

**(A)** Representative micrograph of polystyrene latex bead phagocytosis assay in BV-2 microglial cells treated with recombinant PDGF ligands. Scale bar-20 $\mu$ m **(B)** Quantification from two experiments in duplicates (N=4). Percentage phagocytosis index measured as average number of cells (from 5 fields) that phagocytosed  $\geq 10$  latex beads relative to the average total number of cells (from 5 fields)  $\times 100$ . No significant differences were seen between treatment and control group, one-way AVOVA with Dunnett's multiple comparison test. **(C-F)** Quantitative PCR data of expression levels of phagocytosis related genes; *Cd36*, *Trem2*, *Msr1* and *Scarb1* in the presence of PDGF-BB, N=4 of two independent experiments in duplicates. No significant differences were seen between PDGF-BB treated control group, unpaired t-test. All data are presented as mean  $\pm$  SD. Control - 0.1% BSA in DPBS.

#### 4.2.4 PDGF induced an inflammatory response in microglia

The effect of PDGF ligands on inflammatory response in microglial cells were assessed as reactive microglia are known to induce the expression of pro-inflammatory genes. To this end, BV-2 microglial cells were treated with 50ng/ml

human recombinant PDGF ligands for 3 hours and transcript levels of pro-inflammatory genes were assessed by qPCR. All the PDGF ligands significantly upregulated the expression of *Ccl2*, *Cox-2* (PDGF target genes) and *Tnfa* genes (Fig. 4.7A, B and C respectively).

To further confirm results from BV-2 microglial cells, primary microglial cells were used as they are more physiologically relevant owing to their phenotypic similarities to microglia *in-vivo* (Stansley et al. 2012). To this end, isolated primary microglial cells were also treated with 50ng/ml human recombinant PDGF ligands for 3 hours and the same set of pro-inflammatory genes were assessed by qPCR. In primary microglial cells, all the PDGF ligands significantly upregulated *Ccl2*, *Cox-2* and *Tnfa* genes (Fig. 4.7D, E and F respectively) as seen in BV-2 microglial cells. In addition, significant differences were seen in *Tnfa* response between PDGF-AA and PDGF-CC and PDGF-AB and PDGF-CC (Fig. 4.7F) which was however not seen in BV-2 microglial cells.

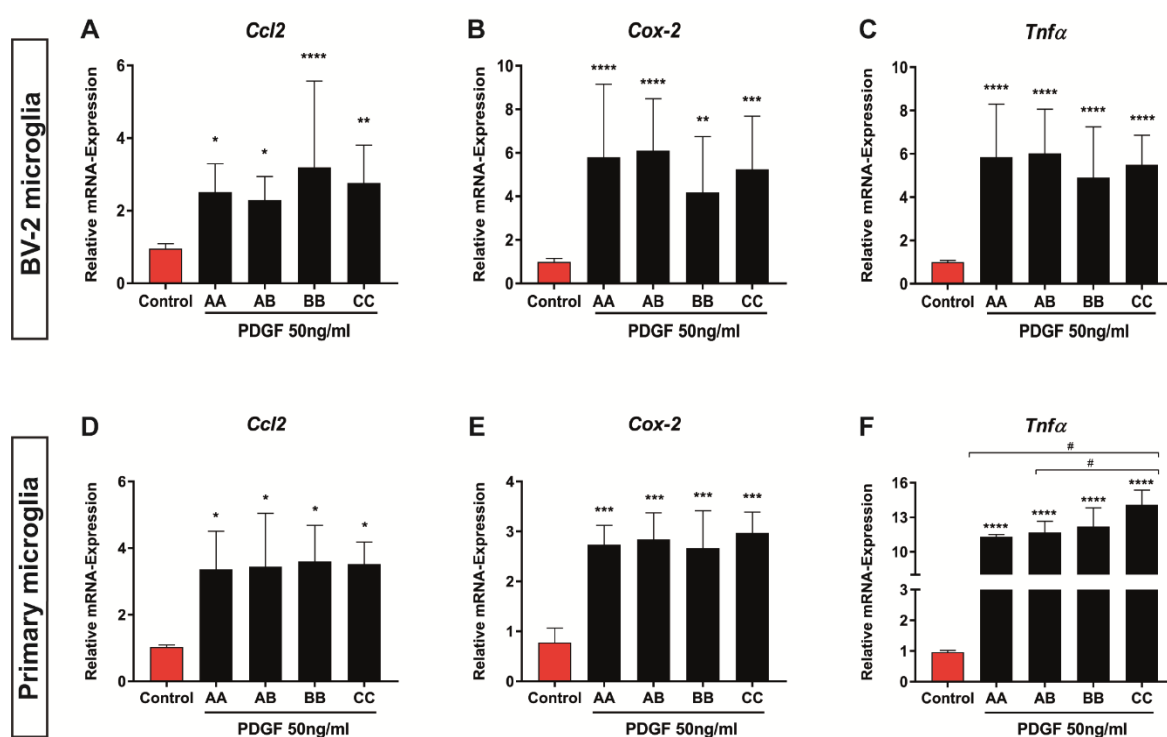

**Figure 4.7 PDGFs upregulated expression of pro-inflammatory genes in BV-2 and primary microglial cells.**

Quantitative PCR data of gene expression levels of *Ccl2* (A, D), *Cox-2* (B, E) and *Tnfa* (C, F) in BV-2 and primary microglial cells respectively. BV-2 microglial cells: N ≥ 9; primary microglial cells: N=4 (two independent experiment in duplicate). All data are presented as mean ± SD. \* $p \leq 0.05$ , \*\* $p \leq 0.01$ , \*\*\* $p \leq 0.001$ , \*\*\*\* $p \leq 0.0001$  compared to

control; # $p \leq 0.05$ , one-way AVOVA with Tukey's multiple comparison test. Control - 0.1% BSA in DPBS.

#### 4.2.5 PDGF decreased intracellular ROS levels

Not only do microglial cells release pro-inflammatory cytokines when activated, they also release neurotoxic factors like toxic oxygen radicals e.g., ROS (Akundi et al. 2005; Block et al. 2007; Bazan 2012; Patro et al. 2016; Takahashi et al. 2016). To this end, the effects of 50ng/ml human recombinant PDGF ligands on the release of cellular ROS was investigated. Using the DCFDA ROS assay kit, PDGF-BB and -CC significantly decreased total ROS levels while no significant effects were seen with PDGF-AA and -AB compared to control although the trend shows an overall decrease in ROS levels with all the PDGF ligands after 3 hours of treatment (Fig. 4.8A). To understand the molecular mechanisms involved in PDGF-mediated decrease of microglia ROS levels, firstly, transcript levels of NADPH oxidases (NOXs) including the dual oxidases (DUOX1 and 2) were assessed as these are the major ROS generating enzymes (Kang 2007; X.-J. Fu et al. 2014; Sun et al. 2016). While the expression of *Nox1* and *Nox2* genes were significantly upregulated (Fig. 4.8B and C), expression of *Nox4*, *Duox1* and *Duox2* genes could not be detected in BV-2 microglial cells. Also, neither *Nox3* nor *Nox5* transcript levels were assessed for in this study because *Nox3* is localised to the inner ear and *Nox5* is absent in mice (Bedard and Krause 2007).

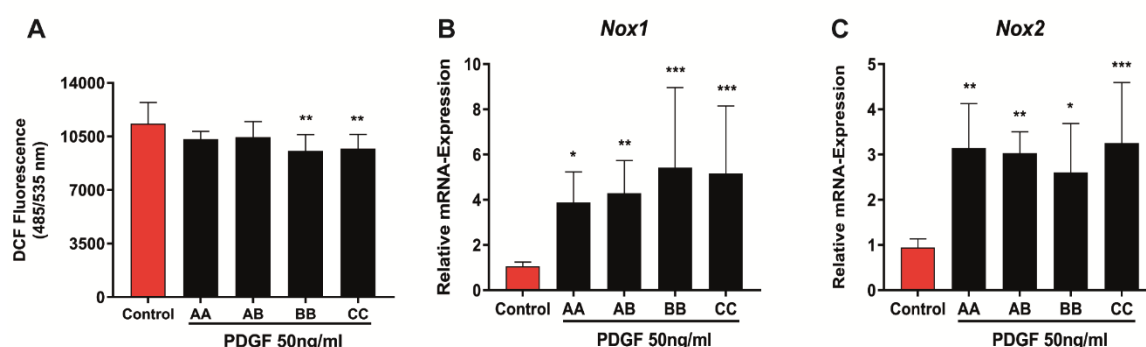

**Figure 4.8 PDGF decreased intracellular ROS levels while inducing expression of NADPH oxidases.**

(A) DCF fluorescence measurement in BV-2 microglial cells treated with recombinant PDGF ligands (N=9-10). (B and C) Quantitative PCR data of gene expression levels of ROS generating enzymes, *Nox1* and *Nox2* in the presence of PDGF ligands (N=8-13). All data are presented as mean  $\pm$  SD. \* $p \leq 0.05$ , \*\* $p \leq 0.01$ , \*\*\* $p \leq 0.001$ , compared to control, one-way AVOVA with Dunnett's multiple comparison test. Control - 0.1% BSA in DPBS; 485/535nm - excitation/emission wavelength respectively.

Secondly, the involvement of the anti-oxidant system was investigated by assessing the expression levels of the anti-oxidant genes, glutathione peroxidase 1 (*Gpx1*), glutathione peroxidase 4 (*Gpx4*), glutathione reductase (*Gsr*), Catalase, superoxide dismutase 1 and 2 (*Sod1* and *Sod2*) in the presence of PDGF ligands (Fig. 4.9A-F). Of all these antioxidant genes, only the expression of *Sod2* gene (Fig. 4.9F) was significantly upregulated by all four ligands while expression of *Gsr* gene (Fig. 4.9C) was upregulated by only PDGF-BB.

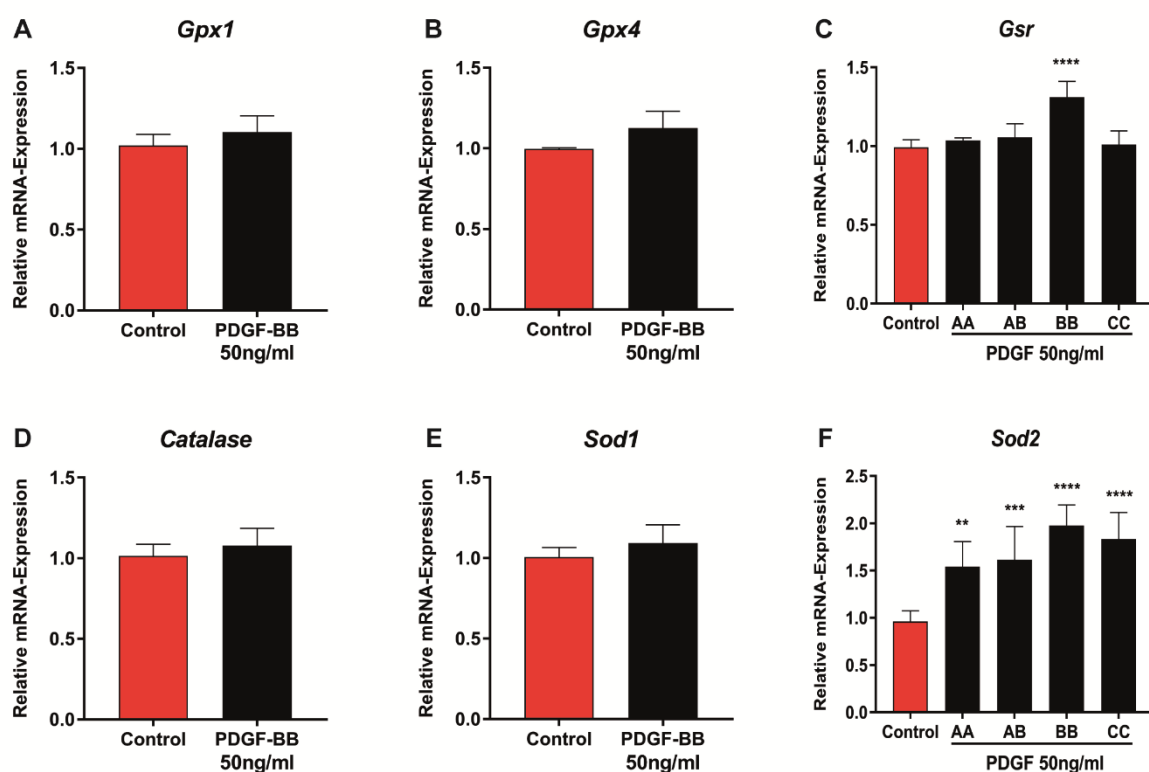

**Figure 4.9 Effect of PDGF-treated BV-2 microglial cells on anti-oxidant genes.** Quantitative PCR data of expression levels of anti-oxidant genes: *Gpx1* (A), *Gpx4* (B), Catalase (D) and *Sod1* (E), N=4 of two independent experiments measured in duplicates. No significant differences were seen between treated and vehicle control, unpaired t-test; *Gsr* (C) and *Sod2* (F), N=4-8. \*\* $p \leq 0.01$ , \*\*\* $p \leq 0.001$ , \*\*\*\* $p \leq 0.0001$  compared to vehicle control, one-way AVOVA with Dunnett's multiple comparison test. All data are presented as mean  $\pm$  SD, vehicle control - 0.1% BSA in DPBS.

#### 4.2.6 Effect of microglia neurotoxicity on neuronal cells

To further test the effect of microglia neurotoxicity, 661W photoreceptor cells were cultured in conditioned medium from PDGF-treated BV-2 microglial cells for 48 hours and caspase-related apoptotic cell death was measured. 661W photoreceptor cells cultured in microglia supernatants from vehicle treated cells showed significantly



higher caspase 3/7 activity when compared to control (baseline) while 661W cells cultured in microglia supernatants from PDGF-ligand treated cells showed decreased caspase 3/7 activity with significant differences seen with PDGF-AA, -AB and -CC when compared to vehicle treated cells (Fig. 4.10). This result is suggestive of the notion that PDGF limits microglial production of neurotoxic molecules.

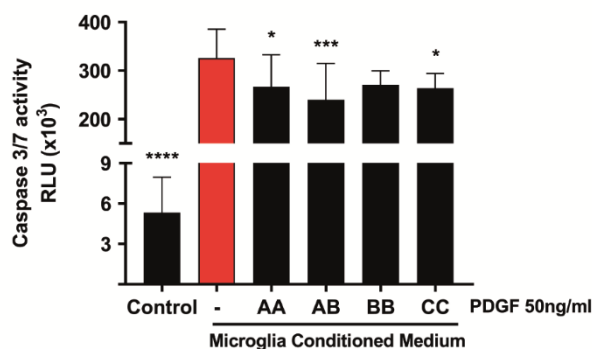
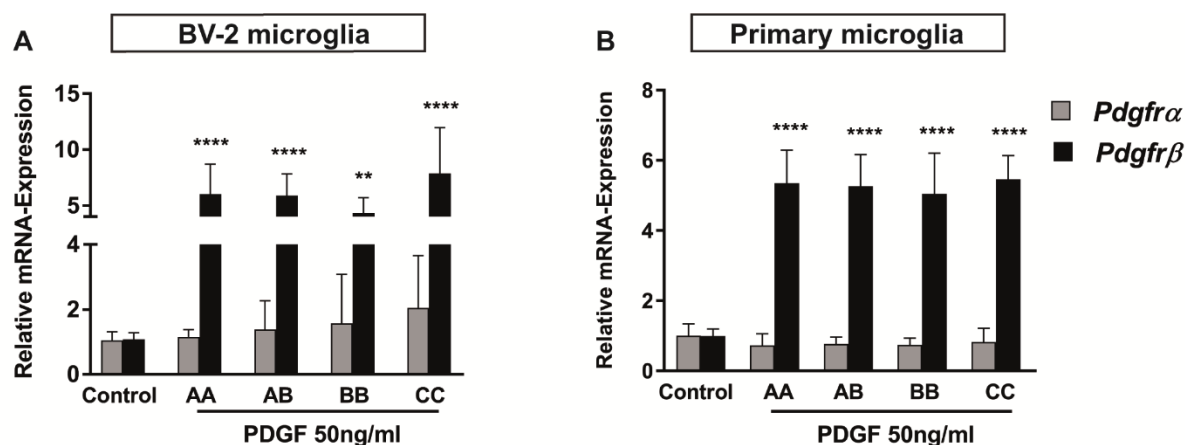

**Figure 4.10 PDGF decreased apoptosis-related caspase 3/7 activity in photoreceptor cells.**

Caspase 3/7 activity in 661W photoreceptor cells at baseline (control - untreated cells) and incubation with BV-2 microglia conditioned medium from vehicle (red bar, denoted as -) and PDGF-treated cells. Data are presented as mean  $\pm$  SD, N=11-12. \* $p \leq 0.05$ , \*\*\* $p \leq 0.001$ , \*\*\*\* $p \leq 0.0001$  compared to vehicle treated. One-way ANOVA with Sidak's multiple comparison test. Vehicle - 0.1% BSA in DPBS; RLU - Relative Light Units.

#### 4.3 Expression of PDGF receptor- $\beta$ but not receptor- $\alpha$ is induced upon microglia activation

Because PDGF effects are mediated by binding to their cognate receptors,  $\alpha$  and  $\beta$ , the next step was to investigate the effect of PDGF induced microglia activation on the receptors. All the PDGF ligands significantly upregulated expression of  $\beta$ -receptor but not  $\alpha$ -receptor in both BV-2 and primary microglial cells (Fig. 4.11A and B respectively). This result is however similar to that seen with LPS activation of microglial cells where  $\beta$ -receptor but not  $\alpha$ -receptor was also upregulated (Fig. 4.1C and B respectively).



**Figure 4.11 PDGF ligands upregulated receptor-β but not receptor-α in both BV-2 and primary microglial cells.**

Quantitative PCR data of gene expression levels of *Pdgfra* (grey) and *Pdgfrβ* (black) in (A) BV-2 and (B) primary microglial cells respectively. BV-2 microglial cells: N=9-16 (of at least 4 independent experiments performed either in duplicates/triplicates); Primary microglial cells: N=4 (two independent experiment performed in duplicates). All data are presented as mean ± SD. \*\* $p \leq 0.01$ , \*\*\*\* $p \leq 0.0001$  compared to control. One-way ANOVA with Dunnett's multiple comparison test. Control - 0.1% BSA in DPBS.

#### 4.4 Antibody blockade of microglial PDGFRβ reduced LPS and PDGF induced inflammatory responses

Having determined the relative expression of PDGF receptors and the effect of both LPS and PDGF treatment on their expressions in both BV-2 and primary microglial cells, next was to determine the role each receptor played in the induction of inflammatory responses. To this end, rat mAbs, APA5 and APB5 were used as pharmacological blockers for receptor α and β respectively.

Firstly, BV-2 microglial cells were pre-treated with 10 μg/ml APA5 and APB5 respectively for 30 minutes followed by 100 ng/ml LPS treatment for 6 hours. Antibody blockade of microglial PDGF receptor-β but not receptor-α significantly attenuated LPS induced *Tnfa*, *Il-6* and *Il-1β* gene expression (Fig. 4.12A-C).

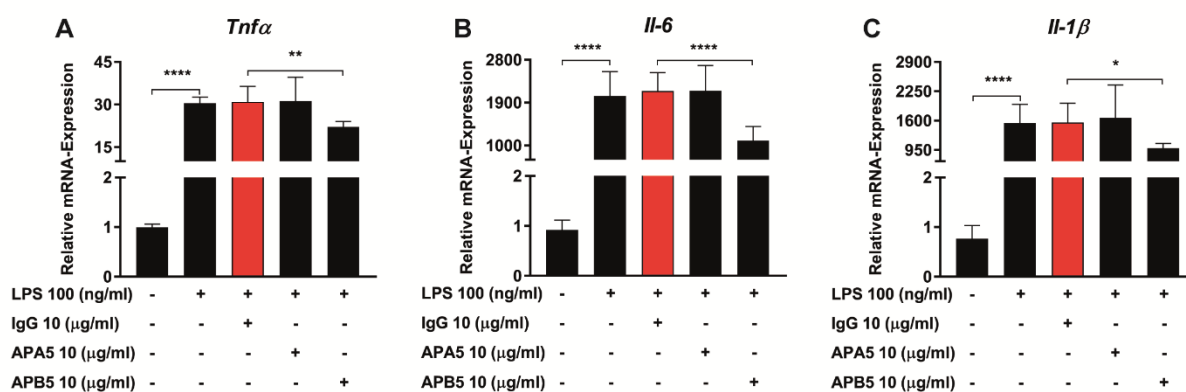

**Figure 4.12 Antibody blockade of microglial PDGFR $\beta$  reduced LPS-induced inflammatory responses.**

Quantitative PCR data of gene expression levels of *Tnfa* (A), *Il-6* (B), and *Il-1 $\beta$*  (C). Data are presented as mean  $\pm$  SD of two independent experiments measured in triplicates (N=5-6). \* $p \leq 0.05$ , \*\* $p \leq 0.01$ , \*\*\*\* $p \leq 0.0001$ , One-way AVOVA with Sidak's multiple comparison test.

Secondly, BV-2 microglial cells were pre-treated with 10  $\mu$ g/ml APA5 and APB5 respectively for 1 hour followed by 50 ng/ml PDGF-BB treatment. Similarly, antibody blockade of microglial PDGF receptor  $\beta$  but not receptor  $\alpha$  significantly attenuated PDGF-BB induced *Ccl2* target gene expression (Fig. 4.13)

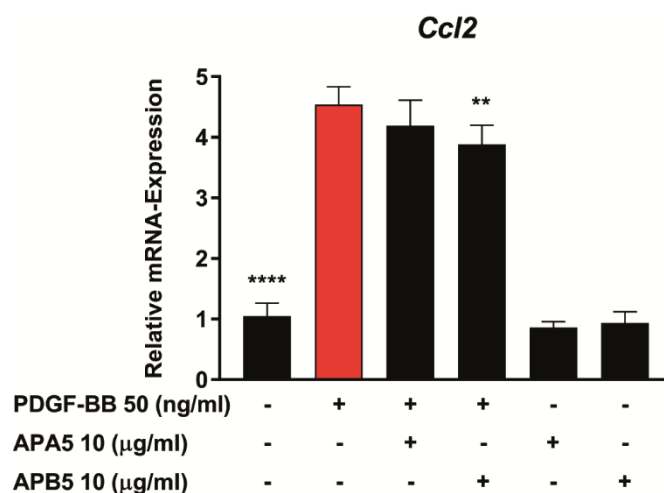

**Figure 4.13 Antibody blockade of microglial PDGFR $\beta$  reduced PDGF-BB-induced *Ccl2* target gene expression.**

Quantitative PCR data of expression levels of *Ccl2* gene induced by PDGF-BB and attenuated by antibody blockade of PDGF receptor  $\beta$ . Data are presented as mean  $\pm$  SD of two independent experiments measured in duplicates (N=4). \*\* $p \leq 0.01$ , \*\*\*\* $p \leq 0.0001$  compared to PDGF-BB group (red bar), one-way AVOVA with Sidak's multiple comparison test.

#### 4.5 Effect of PDGF receptor siRNA-mediated gene silencing on LPS and PDGF induced inflammatory responses

To further corroborate the findings from the pharmacological blockade of PDGF receptor- $\alpha$  and - $\beta$ , BV-2 microglial cells were transfected with PDGFR $\alpha$ , PDGFR $\beta$  and non-targeting scrambled control (scram.) siRNA respectively followed by LPS and PDGF-BB treatment in separate experiments. Transfection of BV-2 microglial cells with these siRNAs for 48 hours resulted in significant knockdown with efficiencies of 70 and 51% for receptor- $\alpha$  (Fig. 4.14A) and - $\beta$  (Fig. 4.14B) respectively with a significant compensatory effect of 20% on receptor- $\beta$  when receptor- $\alpha$  was knocked down (Fig. 4.14C) (compared with non-targeting scrambled control) as demonstrated by qPCR.

In one experiment, cells were transfected with these siRNAs for 48 hours followed by treatment with 100ng/ml LPS for 6 hours. While supernatants were used for protein expression (ELISA), cells were lysed in RNA lysis buffer and processed for gene expression. LPS-mediated induction of *Il-1 $\beta$*  (Fig. 4.14D) and *Ccl2* (Fig. 4.14E) gene expression was attenuated in cells transfected with PDGFR $\beta$  siRNA when compared to non-targeting scrambled control, however, there was a significant increase in *Il-1 $\beta$*  gene expression (Fig. 4.14D) upon *Pdgfra* gene knockdown while no significant effect was seen in CCL2 protein expression (Fig. 4.14F) when both receptors were knocked down.

In a separate experiment, cells were transfected for 48 hours as described above followed by treatment with 50ng/ml PDGF-BB for 3 hours (gene expression) and 24 hours for protein expression (ELISA). PDGF-mediated induction of *Tnfa* gene expression (Fig. 4.14G) was attenuated when both receptor- $\alpha$  and - $\beta$  were knocked down while gene expression of *Ccl2* (Fig. 4.14H) was only attenuated when receptor- $\beta$  but not - $\alpha$  was knocked down with no significant effect observed in CCL2 protein expression (Fig. 4.14I) either in PDGF-BB treatment or in receptor knockdown. Taken together, these results implicate the involvement of both PDGF receptors in LPS- and PDGF-mediated microglia inflammatory response.

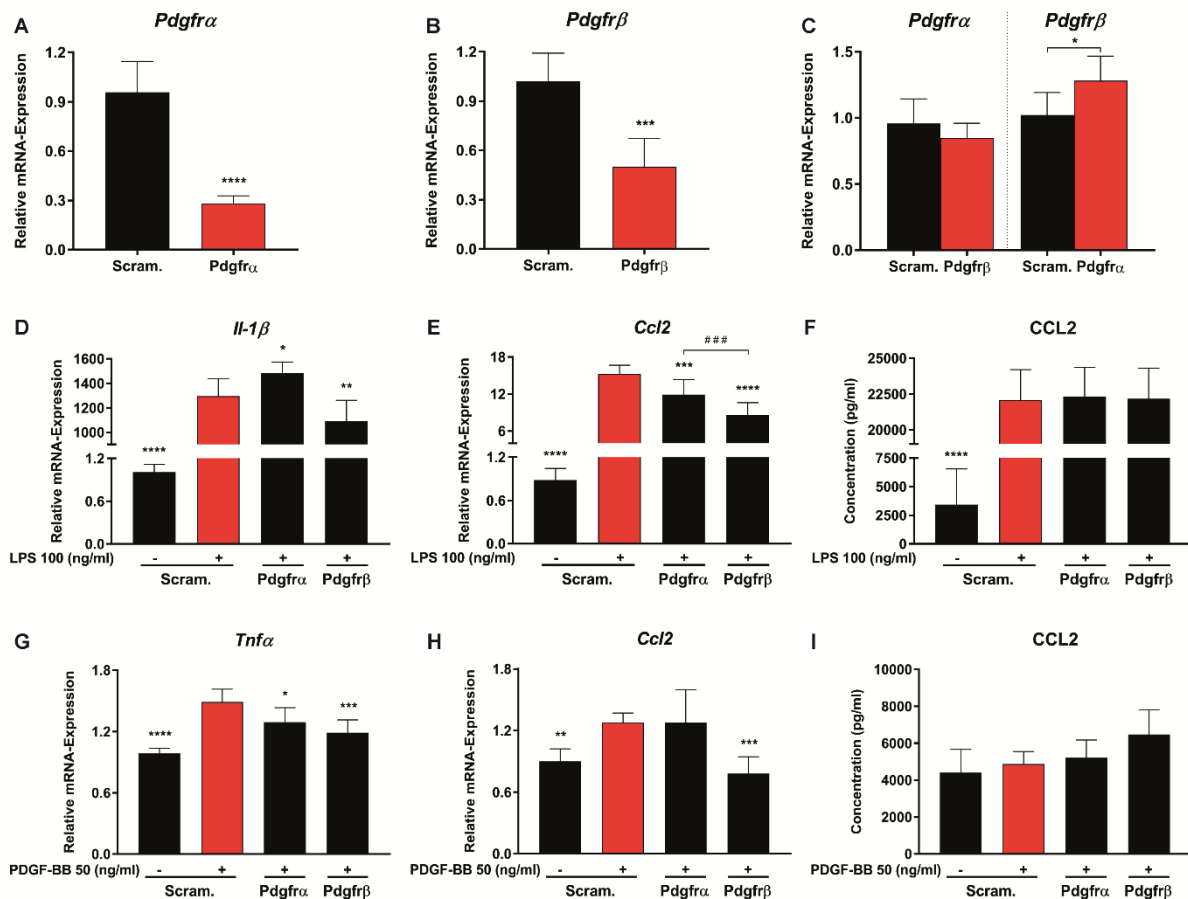

**Figure 4.14** siRNA-mediated gene silencing of *Pdgfr $\beta$*  attenuated LPS and PDGF-BB induced inflammatory responses in BV-2 microglial cells.

Quantitative PCR data of gene expression levels of (A) *Pdgfra*, (B) *Pdgfr $\beta$* , and (C) *Pdgfra* when receptor- $\beta$  was knocked down, and *Pdgfr $\beta$*  when receptor- $\alpha$  was knocked down following 48 hours of transfection with 50nM of the respective siRNAs.  $*p \leq 0.05$ ,  $***p \leq 0.001$ ,  $****p \leq 0.0001$  compared to scram, unpaired t-test. (D-F) Gene expression levels of *Il-1 $\beta$* , *Ccl2* and protein expression of CCL2 respectively following 48 hours of receptor- $\alpha$  and - $\beta$  knockdown plus 6 hours LPS treatment.  $*p \leq 0.05$ ,  $**p \leq 0.01$ ,  $***p \leq 0.001$ ,  $****p \leq 0.0001$  compared to 'scram. + LPS group' (red bar),  $###p \leq 0.001$ , one-way AVOVA with Sidak's multiple comparison test. (G-I) Gene expression levels of *Tnfa*, *Ccl2* and protein expression of CCL2 respectively following 48 hours of receptor  $\alpha$  and  $\beta$  knockdown plus 3 and 24 hours of PDGF-BB treatment for gene and protein expression respectively.  $*p \leq 0.05$ ,  $**p \leq 0.01$ ,  $***p \leq 0.001$ ,  $****p \leq 0.0001$  compared to 'scram. + PDGF-BB group' (red bar), one-way AVOVA with Sidak's multiple comparison test. All data are presented as mean  $\pm$  SD of two independent experiments measured in triplicates (N=6).

---

#### **4.6 PDGF mediated microglial inflammatory response involves MAPK and PI3K/Akt cell signalling pathways**

Having determined the induction of microglia inflammatory response mediated by PDGF, next, was to investigate the intracellular signal transduction pathways involved in this process. Since PDGF is a known mitogen, the involvement of MAPKs and PI3K/Akt signalling pathways were investigated.

First, BV-2 microglial cells were treated with 50ng/ml recombinant PDGF-BB protein and phosphorylation of MAPKs (p38, ERK 1/2, and JNK) and Akt were assessed by western blot (figure 4.15A). Treatment of BV-2 microglial cells with PDGF-BB resulted in a time-dependent increase in phosphorylation of ERK 1/2, JNK, and Akt but not p38 with significant increases seen in phosphorylation of ERK 1/2, JNK and AKT from 15, 120 and 5 minutes respectively compared to vehicle-treated cells (C, D, and E respectively).

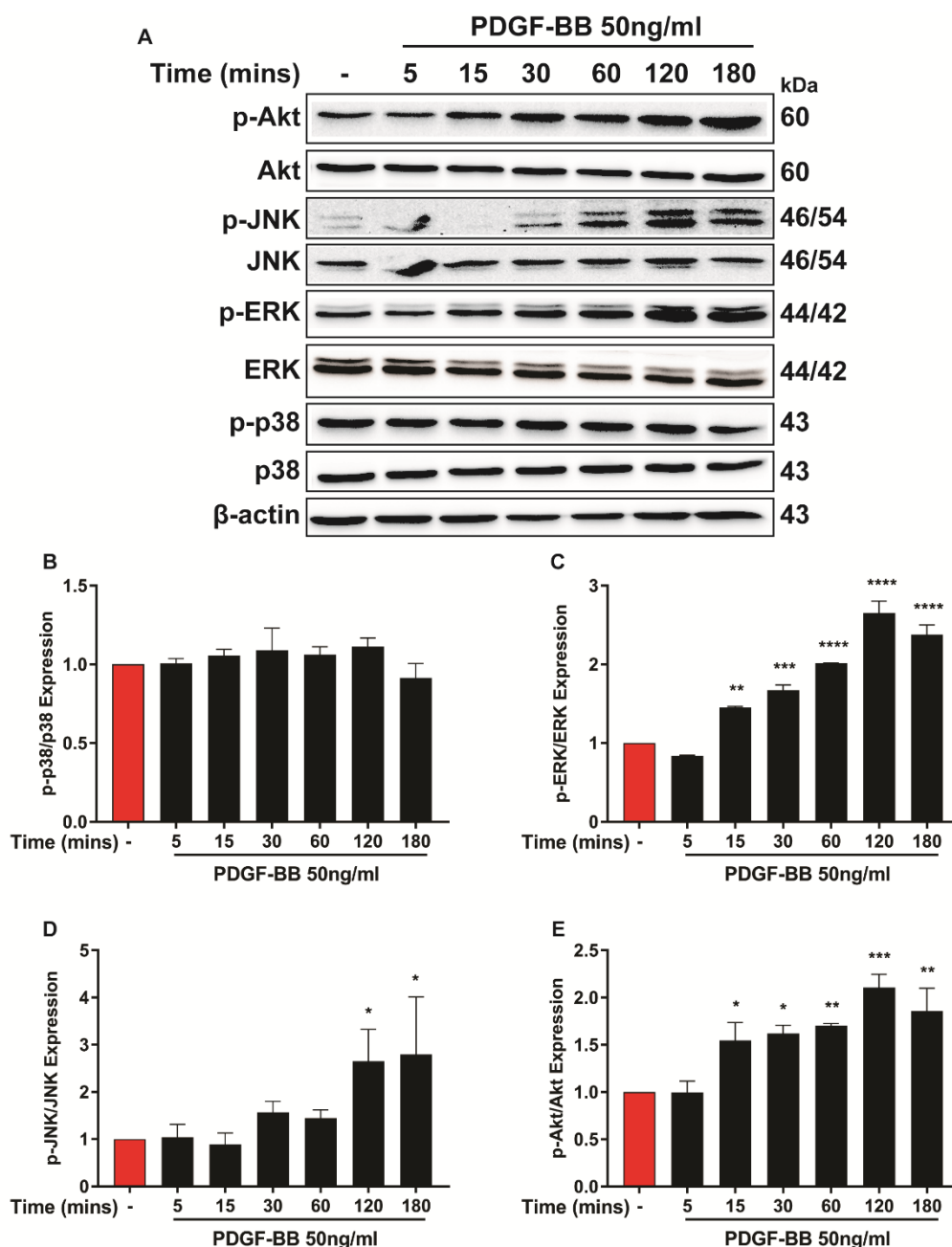

**Figure 4.15 PDGF mediated inflammatory response involves MAPK and PI3K/Akt cell signalling pathways.**

(A) Representative western blot of time-dependent effect of PDGF-BB on total and phosphorylated P38, ERK, JNK, and Akt. (B-E) Densitometric analysis from two immunoblots, \* $p \leq 0.05$ , \*\* $p \leq 0.01$ , \*\*\* $p \leq 0.001$ , \*\*\*\* $p \leq 0.0001$  compared to control (-). One-way ANOVA with Dunnett's multiple comparison test. Data are presented as mean  $\pm$  SD. Control - 0.1% BSA in DPBS.

Second, the functional implication of the MAPKs and PI3K/Akt signalling in PDGF-mediated microglia inflammatory response was investigated. BV-2 microglial cells were pre-treated with inhibitors specific for the respective signalling pathways for 1

---

hour followed by treatment with 50ng/ml recombinant PDGF ligands for 3 hours and subsequently gene expression of *Tnfa* and PDGF-target genes (early response gene), *Ccl2* and *Cox-2* were assessed for. Treatment of BV-2 microglial cells with MAPK and PI3K inhibitors resulted in significant attenuation of PDGF-mediated induction of pro-inflammatory gene *Ccl2*, *Cox-2* and *Tnfa* expression levels however inhibition of PI3K did not attenuate PDGF-mediated induction of *Tnfa* gene expression with all PDGF ligands except PDGF-BB (C). Similar effects with the inhibitors were seen in primary microglial cells with PDGF-BB mediated induction of *Cox-2* and *Tnfa* gene however inhibition of JNK signalling did not attenuate PDGF-BB mediated induction of *Cox-2* gene (Appendix fig 1B and C).



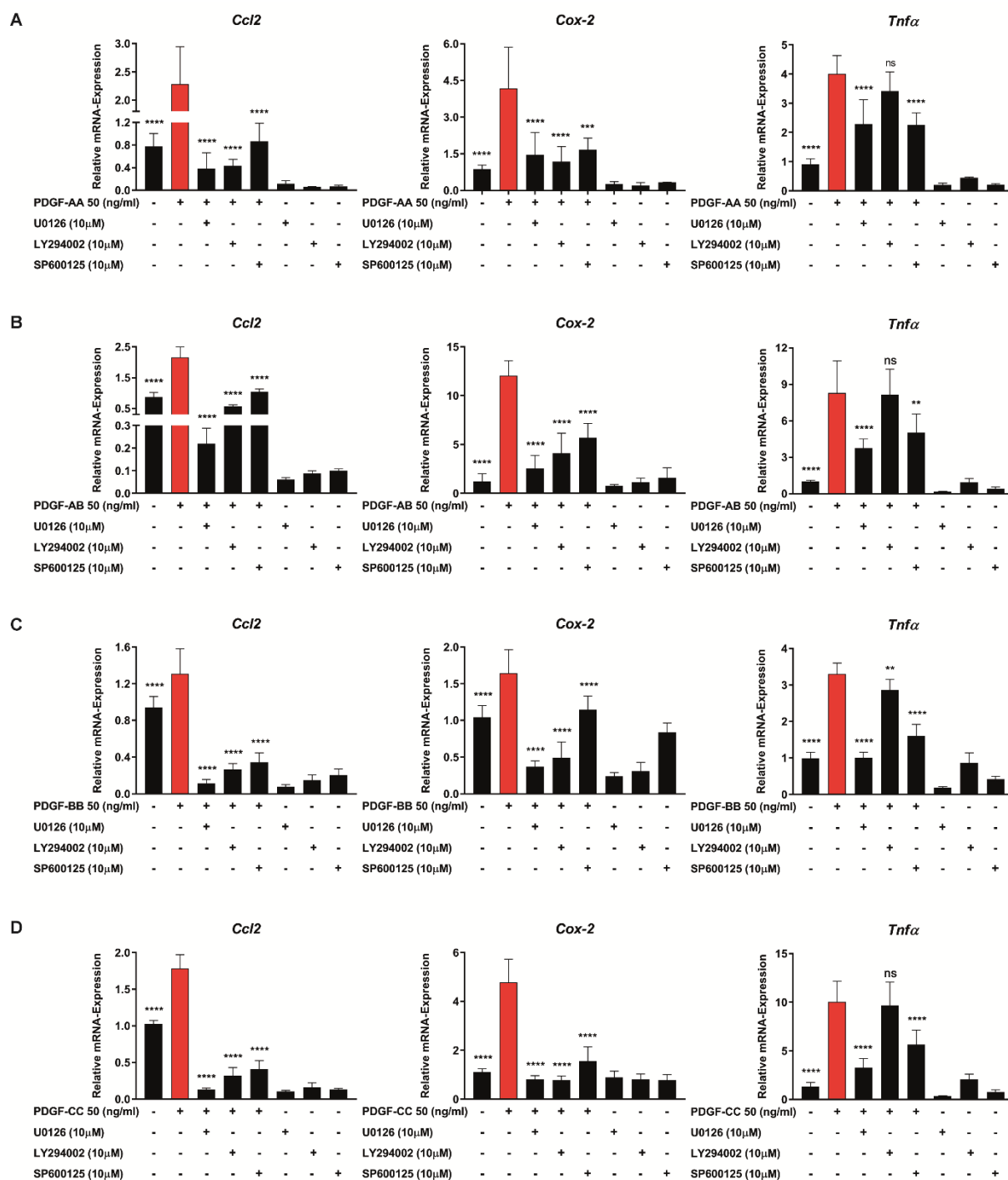

**Figure 4.16 PDGF-mediated induction of inflammatory mediators is inhibited by MEK1/2, JNK and PI3K inhibitors**

(A-D) Quantitative PCR data of gene expression levels of *Ccl2*, *Cox-2* and *Tnfa* in PDGF-AA, -AB, -BB and -CC treated BV-2 microglial cells pre-treated with inhibitors for MEK1/2 inhibitor - U0126, PI3K - LY294002, and JNK - SP600125. Data are presented as mean  $\pm$  SD of two to three independent experiments measured in duplicates and triplicates (N=6-7).  $**p \leq 0.01$ ,  $****p \leq 0.0001$  compared PDGF-treated group (red bar). One-way AVOVA with Sidak's multiple comparison test.

## CHAPTER FIVE: DISCUSSION

Several cellular and molecular processes are implicated in neurodegenerative events including protein aggregate accumulation, oxidative responses, triggering of apoptosis, and impaired mitochondrial function (Höglund and Salter 2013). However, neuroinflammation also correlates with the initiation and development of both acute and chronic neurodegenerative diseases (Frank-Cannon et al. 2009; Amor et al. 2010; Heneka et al. 2014). Although acute neuroinflammatory responses are relatively transient and in general beneficial to the CNS by getting rid of a host of potential CNS harmful substances thereby contributing to tissue homeostasis. However, unresolved acute inflammation becomes chronic and pathologic with neurotoxic effects causing serious neuronal damage, which interferes with CNS homeostasis thus causing an imbalance between restorative and pro-inflammatory responses (Streit et al. 2004; Bazan 2012; McManus and Heneka 2017). This pathological neuroinflammation associated with neurodegeneration is predominantly orchestrated by microglia, the resident immune cells of the CNS (Bazan 2012; Cianciulli et al. 2020). Hence, microglia activation is a hallmark common to neurodegenerative diseases.

Thus, in the quest for understanding microglia activation and how it influences pathologic angiogenesis, this present study focused on investigating the direct association and interaction between microglia and the PDGF/PDGFR system with respect to microglia-mediated neuroinflammatory responses.

### 5.1 BV-2 cell line and primary cells as models for microglia cultures

In order to study the biology of microglia and its role in neuroinflammation, primary microglial cultures and quite a number of immortalised microglial cell lines generated from mice (N9, BV2, and EOC), rats (HAPI), and humans (HMO6 and HMC3) have been established (Sarkar et al. 2018). However, despite the evident differences that have been reported between microglia *in-vivo* and *in-vitro* (Carson et al. 2008), these *in-vitro* cultures are still beneficial in studying microglia properties like activation state, motility, the ability to release numerous factors, characterisation of molecular pathways involved in their activation, as well as other important components characterising microglia, for which efficient examination *in-vivo* might not suffice (Gresa-Arribas et al. 2012; Stansley et al. 2012). Despite the similarities between these culture models, there exists distinct differences that must however be taken into

consideration when a neurodegenerative research model is to be utilised (Stansley et al. 2012).

Primary microglia cultures, mostly generated from neonatal cortex of mouse or rats (Giulian and Baker 1986) (though the utilisation of adult animals is now prevalent in more studies) (Butovsky et al. 2014) show more phenotypic similarities to *in-vivo* cells (Stansley et al. 2012). Following characterisation, these cells were seen to be consistently positive for non-specific esterases, negative for galactocerebroside (GalC, an oligodendrocyte marker); glial fibrillary acidic protein (GFAP, an astrocyte marker); and peroxidase activity (neutrophils); all of which are characteristic of microglial cells (Giulian and Baker 1986). While the measurement of these proteins and cell markers in primary microglia is beneficial, in addition to several other advantages reviewed by Timmerman et al., 2018, the cost, considerable amount of time needed for its preparation, low cell number yield and the limited proliferation capacity, makes its use probably not highly favoured in comparison to other microglial cells lines with shorter preparation time but comparable cell properties (Stansley et al. 2012; Sarkar et al. 2018).

With these, immortalised cell lines mentioned above were generated by infecting primary cells with a retrovirus (Stansley et al. 2012; Timmerman et al. 2018). BV2 and N9 microglial cell lines, of mouse origin, are the two of these type that are most commonly used (Stansley et al. 2012). Of these two mouse cell lines, BV-2 is the best characterised and most used culture model appearing in approximately 75% of publications as reported by Sarkar et al., 2018. The BV-2 cell line was generated by transduction of primary microglia isolated from neonates with the v-raf/v-myc carrying J2 retrovirus (Blasi et al. 1990). Characterisation of these cells, showed that they express MAC1 and MAC2 macrophage markers but are negative for the antigen, MAC-3. In similar vein to primary microglia, these cells were negative for GalC, and GFAP, oligodendrocyte and astrocyte marker respectively, and lacked peroxidase activity while being 90% positive for non-specific esterases (Bignami et al. 1972; Timmerman et al. 2018).

BV-2 cell line has been used in many neuroinflammatory and neurodegenerative studies including those studies on PD and AD (Gao et al. 2013; Griciuc et al. 2013; Velagapudi et al. 2018). They also respond very well to LPS as seen with numerous studies to mention a few (Stansley et al. 2012; Boza-Serrano et al. 2014; Dai et al. 2015) which was also seen in this study by the expression of a number of pro-

inflammatory cytokines including but not limited to Ccl2, Cox-2, Tnf $\alpha$ , Il-6 etc. While BV-2 cells are not in morphology or activation state similar to primary microglia, their ease of use and the disadvantages of primary microglia usage makes BV-2 cells an attractive choice. In light of this, while majority of the experiments in this study were done with BV-2 cells, the key experiments were confirmed with primary microglial cells (isolated from neonatal mice) as proof of concept. Primary microglial cells used in this study were stained for Iba-1 protein to assess microglia purity. Iba-1 is an actin-binding cytoplasmic protein primarily expressed by monocytic lineage cells including microglia in the brain (Imai et al. 1996) and extensively utilised as a microglia marker during immunostainings (Ahmed et al. 2007).

## **5.2 Effect of BV-2 microglia activation on the expression of PDGF ligands and their receptors**

In the current study, BV-2 microglial cells expressed both PDGF receptors, alpha and beta and all of the PDGF ligands but PDGFD. Microglia expression of the PDGF isoforms, PDGF-A, -B and -C are however consistent with expression results seen in a brain radiation necrosis study, where they investigated the roles of PDGF factors and their receptors (Miyata et al. 2014). In this study, authors show microglia (amongst other cells) expression of all PDGFs in undamaged brain tissue and at the peri-necrotic area. While the expression of the PDGFD isoform could not be detected in BV-2 microglial cells, these authors show microglial expression of the PDGF-D isoform in microglia in their study. This difference could however be attributed to differences between rodent and human microglia as reported by Smith and Dragunow, 2014 and Streit et al., 2014.

LPS, a confirmed activator of microglial cells, binds to TLR4 and leads to rapid activation of various intracellular signalling pathways thus inducing the expression of a broad spectrum of endogenous mediators including pro-inflammatory cytokines like TNF $\alpha$ ; interleukins like IL-6 and IL-1 $\beta$  (Alexander and Rietschel 2001). In this current study, following LPS stimulation, an induction of TNF $\alpha$  expression was seen confirming microglia activation while significant increases in gene expression of PDGFB and PDGFR $\beta$  was seen. Also, a significant decrease in expression of PDGFC was seen while the expression of PDGFA and PDGFR $\alpha$  were not significantly altered. Furthermore, increased expression of both PDGFB and its receptor- $\beta$  were sustained at protein level as seen by significant increases in expression of both proteins using

two independent approaches, ICC and WB. Decreased PDGFC expression seems to be contrary to expected results given that the PDGF-PDGFR signalling play critical role in and induces inflammation (Olson and Soriano 2011; Miyata et al. 2014) as well as contributing to a number of inflammatory associated diseases like asthma (Kardas et al. 2020), renal interstitial fibrosis (Eitner et al. 2008), and atherosclerosis (He et al. 2015) to mention a few.

The co-expression of both PDGF ligands and receptors seen in microglial cells in this study is suggestive of autocrine signalling mechanisms. Such autocrine PDGFR signalling have been seen in neural progenitor cells, regulating proliferation (Erlandsson et al. 2006), in lens epithelium, contributing to lens development through the co-expression of PDGFA and PDGFR $\alpha$  (Andrae et al. 2008) and particularly in tumour cells where it contributes to their growth and survival (Maxwell et al. 1990; Lokker et al. 2002).

### **5.3 Effect of PDGF on microglia functional properties**

Microglia is known to be involved in a number of physiological roles, as it relates with this study, in surveillance and monitoring with their dynamic processes (Hickman et al. 2018), migration to sites of injury or neuronal death to phagocytose dying or dead cells or other forms of debris (Fuhrmann et al. 2010; Lull and Block 2010; Krasemann et al. 2017), in regulating host defense against infectious pathogens (Hickman et al. 2018). Thus, any functional irregularity causes an imbalance initiating the onset of neurodegeneration (Hickman et al. 2018).

Here, the effect of ligand mediated PDGF receptor activation in microglia were assessed on these functional properties in order to characteristically understand microglia-PDGFR system interaction. Firstly, results show that PDGF ligands induced an amoeboid-like phenotype in BV-2 microglial cells indicating a change in microglia homeostasis. Consistent with this finding, a downregulation of the *P2ry12* gene was seen. *P2ry12* is a member of the purinergic receptors, and one of the 'sensitive' genes used by microglia processes to sense changes within their environment and facilitate tissue homeostasis (Inoue 2002; Haynes et al. 2006; Hickman et al. 2013; Fourgeaud et al. 2016), thus a change in microglia homeostasis results in downregulation of these genes (Hickman et al. 2013) as seen in this study. Furthermore, PDGF ligands did not significantly affect microglia migration though pro-migratory genes *Ccl2*, *Ccl3* and *Ccl5* were significantly upregulated which should have translated to the needed response.

A possible explanation for this could be that PDGF is not a strong stimulant for BV-2 microglial cells compared to LPS evidently seen by fold changes in pro-inflammatory gene expression between PDGF and LPS. Another plausible reason could be that PDGF cellular responses have been reported to be independent of gene expression and protein synthesis (Andrae et al. 2008).

Microglia phagocytic activity has been reported to increase upon inflammation *in-vivo* (Sierra et al. 2010; Karlstetter et al. 2014). However, in this study, PDGF ligands did not significantly affect microglia phagocytic capacity while phagocytosis related genes, *Cd36*, *Trem2*, scavenger receptors: *Msr1* and *Scarb1* were also not significantly changed. These chemokines/chemoattractant and phagocytosis related genes are amongst the genes involved in house-keeping functions (Hickman et al. 2018). TREM2 is particularly indispensable for apoptotic cell membrane phagocytosis by microglia (Neumann and Takahashi 2007).

#### **5.4 PDGF induced an inflammatory response in microglia**

During activation, microglial cells release pro-inflammatory mediators that drive immune/inflammatory responses (Alexander and Rietschel 2001). As mentioned earlier, while these acute neuroinflammatory responses are in general beneficial to the CNS, chronic neuroinflammatory responses thus have neurotoxic effects (Czeh et al. 2011; Bazan 2012).

Here, the effects of PDGF ligands on inflammatory responses in microglia was investigated by assessing pro-inflammatory gene expression. In BV-2 microglial cells, all the PDGF ligands used significantly upregulated the expression of pro-inflammatory mediators after 3 hours including the expression of *Tnfa*, the chemokines, *Ccl2*, *Ccl3* and *Ccl5*, and the pro-inflammatory enzyme, *Cox-2*. *Ccl2* and *Cox-2* (PTGS2) are regarded as PDGF target genes (Wu et al. 2008). To further confirm results from BV-2 microglial cells, primary microglial cells were used as they are more physiologically relevant owing to their phenotypic similarities to microglia *in-vivo* (Stansley et al. 2012). Similar results were also seen in primary microglial cells.

Not only is this result consistent with the numerous studies as mentioned above of increased pro-inflammatory gene expression during microglia activation, it is also consistent with the results of PDGF induced *Ccl2* expression in fibroblast and SMCs (Freter et al. 1996; Poon et al. 1996; He et al. 2015) as well as in astrocytes (Bethel-Brown et al. 2012).

## 5.5 Effect of PDGF-mediated decrease in intracellular ROS levels in microglia

Not only do microglial cells release pro-inflammatory cytokines in the course of being activated, they also release neurotoxic factors like ROS (Akundi et al. 2005; Block et al. 2007; Bazan 2012; Patro et al. 2016; Takahashi et al. 2016). On the other hand, ROS involvement in PDGFR-signalling has been well established since it was firstly observed by Sundaresan et al., 1995 where authors reported the induction of intracellular ROS levels in VSMCs by PDGF. Since then, numerous studies have looked at ROS involvement in PDGFR-signalling in different cell types (lens epithelial cells, VSMCs, fibroblasts) and have reported that PDGF induces ROS production via NADPH oxidases (Marumo et al. 1997; Suh et al. 1999; Kreuzer et al. 2003; Chao-Wei Chen et al. 2004; Spadoni et al. 2015).

Here, the effect of PDGF ligands on intracellular ROS production in BV-2 microglial cells was investigated. However, contrary to the above referenced studies, PDGF ligands, specifically, PDGF-BB and -CC decreased total ROS levels in BV-2 microglial cells. Thus, to understand the molecular mechanisms involved herein, gene expression levels of the Nox/Duox enzymes were assessed. The Nox/Duox enzymes (having seven members, Nox-1 to Nox-5, Duox-1 and Duox-2) are the only enzyme system that generates ROS in a controlled manner (Kang 2007; X.-J. Fu et al. 2014; Sun et al. 2016; Haslund-Vinding et al. 2017). Though, a number of reports (some of which have been referenced above) have implicated these enzymes as the probable source of ROS in PDGF-stimulated systems, the mitochondria may also produce ROS specifically  $O_2^-$  as by-products of the electron transport chain (ETC) complex I and III (Reczek and Chandel 2015; Haslund-Vinding et al. 2017). Of the seven Nox/Duox family, only *Nox1* and *Nox2* gene expression could be detected in BV-2 microglial cells while expression of *Nox3* and *Nox5* genes were not assessed for in this study as expression of *Nox3* is localised to the inner ear and *Nox5* is absent in mice (Bedard and Krause 2007). Although the expression of *Nox4* has been reported in microglia (Haslund-Vinding et al. 2017), it could not be detected in BV-2 microglial cells in this present study.

Here, the expression of *Nox1* and *Nox2* genes were significantly upregulated following PDGF stimulation. First, the induced expression of *Nox1* is consistent with reports of Suh et al., 1999, of *Nox1* being a mitogenic oxidase involved in PDGF induced ROS while the expression of *Nox2* is also consistent with literature where it is often referred

to as phagocytic Nox (Panday et al. 2015) with high expression levels in rodent as well as human microglia (Sorice et al. 2014). Likewise, the PDGF induced upregulation of *Nox2* gene expression seen in this study is in tandem with results of Spadoni et al., 2015 where induced gene expression of *Nox2* enzyme was also seen in skin fibroblasts following PDGF stimulation. However, this induced *Nox1* and *Nox2* gene expression levels did not impact on increased ROS production by the PDGF ligands in this study, instead, a decrease in ROS levels were seen with PDGF-BB and -CC which is consistent with results of Krieger-Brauer and Kather, 1995, where PDGF-BB also inhibited NADPH-dependent  $H_2O_2$  release in 3T3-L1 pre-adipocyte cells.

However, since the temporal and spatial regulation of enzymes that generate ROS and the cellular antioxidant enzymes are responsible for the transient burst observed in receptor-dependent intracellular ROS release (Kang 2007), the involvement of the anti-oxidant system was investigated by assessing the expression levels of the different anti-oxidant enzymes. Of the antioxidant genes assessed, the expression of only glutathione reductase (*Gsr*) and superoxide dismutase 2 (*Sod2*) were significantly upregulated upon PDGF stimulation. While only PDGF-BB significantly upregulated the expression of *Gsr* gene, all four ligands used significantly upregulated *Sod2* gene expression. *Gsr* catalyses the reduction of the oxidised form of glutathione (GSSG) to the reduced form (GSH) during Gpx-catalysed ROS detoxification when GSH is oxidised to GSSG (Hirrlinger et al. 2000).

While three isoforms of SODs are known to exist (Miller 2012), only SOD1 (cytosolic Cu/Zn-SOD), and SOD2 (mitochondrial Mn-SOD) were assessed for in this study as SOD3 (extracellular, EC-SOD) is the predominant antioxidant enzyme present extracellularly (Marklund 1984). The dismutation of the highly reactive superoxide anion ( $O_2^-$ ) into oxygen and the less reactive specie,  $H_2O_2$  is catalysed by SOD (Kim et al. 2015).

In this study, a significant upregulation of mitochondrial SOD2 but not cytoplasmic SOD1 was seen upon PDGF stimulation, an implication that mitochondrial ROS might be in play as SOD2 is known to specifically catalyse the dismutation of the superoxide anion generated as a by-product of the mitochondrial ETC (Fukai and Ushio-Fukai 2011), more so that the mitochondrial ETC has been implicated as another source of cytosolic ROS (Reczek and Chandel 2015; Haslund-Vinding et al. 2017). However, further studies need to be done to confirm the specific contribution of mitochondrial ROS in PDGF stimulated BV-2 microglial cells.



Overall, an upregulation of the anti-oxidant enzymes seen here seems to be a parallel defence response to ongoing cellular oxidative stress (Hirrlinger et al. 2000), in an attempt to regulate and maintain the physiological balance with oxidants. However, the shift in balance in favour of the anti-oxidant genes overwhelming that of oxidative response might be responsible for the overall decrease in cellular ROS levels seen with PDGF ligands in this study.

### **5.6 Effect of microglia neurotoxicity on neuronal cells**

Phagocytosis of dying or damaged cells have been used to describe reactive microglia (Kraft and Harry 2011; Bazan 2012; Perry and Holmes 2014; Patro et al. 2016), in addition, Gupta et al., 2003 have shown that in patients with retinal degenerative diseases such as AMD and retinitis pigmentosa (RP), reactive microglia have been detected in impaired photoreceptors. Not only have these cells been seen to phagocytose apoptotic rod cells in a RP mouse model, they also ingested rod cells that were stressed but still living which were negative for apoptotic markers (Zhao et al. 2015). As such, Karlstetter et al., 2015, opined that the activation of microglia in the retina cannot just be viewed as a bystander effect as it contributes actively to the apoptosis of photoreceptor cells during retinal degeneration.

On this basis, the effect of microglial neurotoxicity on 661W photoreceptor cells were investigated using cultured conditioned medium from PDGF-treated BV-2 microglial cells while measuring caspase-related 661W apoptotic cell death. In this study, PDGF ligands were seen to have decreased microglial neurotoxicity on 661W photoreceptor cells suggestive that PDGF probably limits microglial production of neurotoxic molecules.

### **5.7 Role of PDGF receptors and downstream signalling pathway in microglia inflammatory responses**

In an effort to determine the role and or contribution of each of the PDGFRs, expression of both receptors were investigated in PDGF ligand induced inflammatory responses in microglia. Significant upregulation of gene expression levels of  $\beta$ -receptor but not  $\alpha$ -receptor in both BV-2 and primary microglial cells respectively suggested an involvement of the  $\beta$ -receptor in PDGF mediated inflammatory responses in microglia. This induced gene expression of  $\beta$ -receptor but not  $\alpha$ -receptor is similar with earlier result in this study where LPS also induced the expression of the  $\beta$ - but not the  $\alpha$ -receptor further substantiating the involvement of the  $\beta$ -receptor.

However, using both pharmacological and genetic approaches, the relative contribution of each receptor in these responses could be better understood. Results show that antibody blockade of microglial PDGFR $\beta$  with APB5 but not blockade of PDGFR $\alpha$  with APA5 significantly decreased LPS induced inflammatory responses (*Tnfa*, *Il-6* and *Il-1 $\beta$* ) and PDGF-BB induced chemoattractant gene, *Ccl2*. This decrease in inflammatory responses seen with the pharmacological blockade of receptor- $\beta$  but not receptor- $\alpha$  is however consistent with previous results that have been seen in inflammatory associated disease mouse model. Firstly, Hideto et al., 2001, showed that using the same monoclonal antibody blockers, APA5 and APB5, the functional blockade of PDGF receptor- $\beta$  but not of receptor- $\alpha$  blocked the accumulation of VSMCs in fibrous cap lesions in mice deficient in Apolipoprotein E. Secondly, Kishi et al., 2018, have also shown that using the same specific blocking antibodies, blockade of PDGF receptor- $\beta$  but not of receptor- $\alpha$  lessened the pulmonary fibrosis induced by bleomycin in mice.

Consistently, siRNA-mediated gene silencing of *Pdgfr $\beta$*  significantly decreased both LPS-induced (*Il-1 $\beta$*  and *Ccl2*) and PDGF-BB induced (*Tnfa* and *Ccl2*) inflammatory responses although gene silencing of *Pdgfra* also significantly decreased LPS induced *Ccl2* and PDGF-BB induced *Tnfa* gene expression while increasing LPS induced *Il-1 $\beta$*  expression. Attenuation of PDGF-BB mediated induction of *Ccl2* gene expression seen in this present study is in accordance with the result of Bethel-Brown et al., 2012, where it was reported that PDGFR $\beta$  engagement is important for increase in MCP-1 (*Ccl2*) expression induced by PDGF in human astrocytic cells. In this study, authors report that PDGFR $\beta$  gene silencing attenuated the increased *Ccl2* gene expression, an effect not seen in non-siRNA controls cells. The reduction in responses seen with *Pdgfra* gene silencing were not as pronounced as that seen with silencing of *Pdgfr $\beta$*  gene as significant differences were seen between these two responses in LPS induced expression of chemo-attractant gene, *Ccl2*.

Taken together, these results implicate both PDGF receptor- $\alpha$  and - $\beta$  in LPS and PDGF induced inflammatory responses in BV-2 microglial cells, as such the relative contribution of each of the receptors in these responses could not be substantiated, perhaps, a third approach would be needed.

Despite that the relative contribution of each receptor could not be delineated, results from the pharmacological inhibition cannot be completely overlooked as the most and highly specific way to block or inhibit PDGFR signalling is by inhibition extracellularly

either with antibodies (as was done in this present study with monoclonal antibodies) or with dominant-negative ligands (Andrae et al. 2008; Chen et al. 2013). This approach of extracellular targeting of PDGFRs have been successfully used in studies that served as a foundation for several other pre-clinical and clinical studies. Jo et al., 2006, one of the very first studies, tested the combination of PDGFR $\beta$ -blocking antibody (APB5) and anti-VEGF DNA aptamer in a corneal and choroidal neovascularization model and found that this combination in comparison with anti-VEGFA monotherapy was more effective in regressing vessels at sites of new vessel growth. Similarly, Strittmatter et al., 2016, showed that the blockade of pericyte function in a mouse model of AMD with neutralising PDGFR $\beta$ -antibodies caused a reduction in CNV.

While siRNA-mediated gene silencing is a highly robust technique to research a cell's loss-of-function effect, this technique is limited by its unspecificity and off-target effects are a common occurrence (Lin et al. 2005). Such off-target effects might be responsible for the significant upregulation seen with *Il-1 $\beta$*  gene expression upon PDGFR $\alpha$  gene silencing as this result seems to deviate from the trend when compared to other pro-inflammatory cytokines. More so that the expression of the *Pdgfra* gene was not significantly affected upon microglia activation either with LPS or with the PDGF ligands. Off-target effects of gene knock-down has been reported to involve several mechanisms which includes; the use of high siRNA concentrations causing a total up- or down-regulation of genes (Persengiev et al. 2004; Semizarov et al. 2004), the degradation of mRNA caused by partial sequence complementation (Jackson et al. 2003) and miRNA-like translational inhibition (Saxena et al. 2003; Zeng et al. 2003; Scacheri et al. 2004).

PDGFs, via their two receptors, alpha and beta, trigger a number of intracellular signalling pathways (Andrae et al. 2008; Ostendorf et al. 2012; Heldin and Lennartsson 2013), however, activation of the MAPK and the PI3K/Akt pathway are the two most characterised pathways through which cellular responses are being mediated (Li et al. 2007). In this study, the ERK, JNK, and p38 MAPK and the PI3K/Akt pathways were evaluated for their involvement in PDGF-mediated inflammatory responses in BV-2 microglial cells. First, results show significant increases in phosphorylation of Akt, ERK, JNK but not P38 upon PDGF-BB stimulation in a time-dependent manner. Second, the functional relevance of the phosphorylated proteins were investigated. Using small molecule kinase inhibitors, the PDGF-mediated

induction of pro-inflammatory cytokines were significantly attenuated thus clearly defining a role for ERK, JNK MAPKs and PI3K/Akt signalling pathway.

Phosphorylation of the MAPKs and Akt mediated by PDGF-BB and the subsequent blocking of these pathways which attenuated PDGF-mediated inflammatory responses is in accordance with similar results that have been reported in other cell types including astrocytes, and SMCs (Bethel-Brown et al. 2012; Zhang et al. 2015) to mention a few.

## CHAPTER SIX: CONCLUSION AND PERSPECTIVE

PDGFR signalling plays a fundamental regulatory role in microglia where these results provide the first evidence of the direct association and interaction between them. Most of the studies involving PDGFR signalling have been done in smooth muscle cells and fibroblasts.

Results presented herein is indicative of PDGFR autocrine signalling in microglia as seen by the expression of both ligands and receptors. Ligand-mediated activation of PDGFR induced an activation state in microglia as seen by morphological changes accompanied by the release of pro-inflammatory mediators. However, whether this activation state is sufficient to sustain a prolonged inflammatory response is unknown as results from other functional assays that define “microglia activation” such as an increase in ROS and neurotoxicity were utterly opposite.

While the complex interplay between several signalling pathways in microglia is of utmost importance, their individual roles cannot be downplayed. As such, a detailed characterisation of PDGFR signalling in microglia is therefore warranted beyond *in-vitro* studies. This characterisation will adequately address its role during microglia homeostatic and activation state. It will also provide useful information in pathological conditions like nAMD, where the involvement of both systems has been implicated.

## REFERENCES

- Adams, R.H. and Alitalo, K. (2007) Molecular regulation of angiogenesis and lymphangiogenesis. *Nature Reviews Molecular Cell Biology* 8 (6), 464–478.
- Agrawal, S., Anderson, P., Durbeej, M., van Rooijen, N., Ivars, F., Opdenakker, G. and Sorokin, L.M. (2006) Dystroglycan is selectively cleaved at the parenchymal basement membrane at sites of leukocyte extravasation in experimental autoimmune encephalomyelitis. *The Journal of experimental medicine* 203 (4), 1007–1019.
- Ahmed, Z., Shaw, G., Sharma, V.P., Yang, C., McGowan, E. and Dickson, D.W. (2007) Actin-binding proteins coronin-1a and IBA-1 are effective microglial markers for immunohistochemistry. *The journal of histochemistry and cytochemistry: official journal of the Histochemistry Society* 55 (7), 687–700.
- Ajami, B., Bennett, J.L., Krieger, C., McNagny, K.M. and Rossi, F.M. V (2011) Infiltrating monocytes trigger EAE progression, but do not contribute to the resident microglia pool. *Nature Neuroscience* 14 (9), 1142–1149.
- Ajami, B., Bennett, J.L., Krieger, C., Tetzlaff, W. and Rossi, F.M. V (2007) Local self-renewal can sustain CNS microglia maintenance and function throughout adult life. *Nature Neuroscience* 10 (12), 1538–1543.
- Akhtar-Schäfer, I., Wang, L., Krohne, T.U., Xu, H. and Langmann, T. (2018) Modulation of three key innate immune pathways for the most common retinal degenerative diseases. *EMBO molecular medicine* 10 (10), e8259.
- Akimoto, K., Takahashi, R., Moriya, S., Nishioka, N., Takayanagi, J., Kimura, K., Fukui, Y., Osada, S. i, Mizuno, K., Hirai, S. i, Kazlauskas, A. and Ohno, S. (1996) EGF or PDGF receptors activate atypical PKC $\lambda$  through phosphatidylinositol 3-kinase. *The EMBO journal* 15 (4), 788–798.
- Akiyama, H., Kachi, S., Silva, R.L.E., Umeda, N., Hackett, S.F., McCauley, D., McCauley, T., Zoltoski, A., Epstein, D.M. and Campochiaro, P.A. (2006) Intraocular injection of an aptamer that binds PDGF-B: a potential treatment for proliferative retinopathies. *Journal of cellular physiology* 207 (2), 407–412.
- Akundi, R.S., Candelario-Jalil, E., Hess, S., Hüll, M., Lieb, K., Gebicke-Haerter, P.J. and Fiebich, B.L. (2005) Signal transduction pathways regulating cyclooxygenase-2 in lipopolysaccharide-activated primary rat microglia. *Glia* 51 (3), 199–208.
- Alessi, D.R., Deak, M., Casamayor, A., Caudwell, F.B., Morrice, N., Norman, D.G., Gaffney, P., Reese, C.B., MacDougall, C.N., Harbison, D., Ashworth, A. and Bownes, M. (1997) 3-Phosphoinositide-dependent protein kinase-1 (PDK1): structural and functional homology with the Drosophila DSTPK61 kinase. *Current biology: CB* 7 (10), 776–789.
- Alessi, D.R., James, S.R., Downes, C.P., Holmes, A.B., Gaffney, P.R., Reese, C.B. and Cohen, P. (1997) Characterization of a 3-phosphoinositide-dependent protein kinase which phosphorylates and activates protein kinase Balpha. *Current biology: CB* 7 (4), 261–269.

- Alexander, C. and Rietschel, E.T. (2001) Bacterial lipopolysaccharides and innate immunity. *Journal of endotoxin research* 7 (3), 167–202.
- Alliot, F., Godin, I. and Pessac, B. (1999) Microglia derive from progenitors, originating from the yolk sac, and which proliferate in the brain. *Brain research. Developmental brain research* 117 (2), 145–152.
- Aloisi, F. (2001) Immune function of microglia. *Glia* 36 (2), 165–179.
- Ambati, J., Ambati, B.K., Yoo, S.H., Janchulev, S. and Adamis, A.P. (2003) Age-Related Macular Degeneration: Etiology, Pathogenesis, and Therapeutic Strategies. *Survey of Ophthalmology* 48 (3), 257–293.
- Ameres, S.L., Martinez, J. and Schroeder, R. (2007) Molecular Basis for Target RNA Recognition and Cleavage by Human RISC. *Cell* 130 (1), 101–112.
- Amor, S., Puentes, F., Baker, D. and van der Valk, P. (2010) Inflammation in neurodegenerative diseases. *Immunology* 129 (2), 154–169.
- Andjelković, M., Alessi, D.R., Meier, R., Fernandez, A., Lamb, N.J., Frech, M., Cron, P., Cohen, P., Lucocq, J.M. and Hemmings, B.A. (1997) Role of translocation in the activation and function of protein kinase B. *The Journal of biological chemistry* 272 (50), 31515–31524.
- Andjelković, M., Jakubowicz, T., Cron, P., Ming, X.F., Han, J.W. and Hemmings, B.A. (1996) Activation and phosphorylation of a pleckstrin homology domain containing protein kinase (RAC-PK/PKB) promoted by serum and protein phosphatase inhibitors. *Proceedings of the National Academy of Sciences of the United States of America* 93 (12), 5699–5704.
- Andrae, J., Gallini, R. and Betsholtz, C. (2008) Role of platelet-derived growth factors in physiology and medicine. *Genes & development* 22 (10), 1276–1312.
- Annika, A., Alexandra, A. and Christer, B. (2005) Endothelial/Pericyte Interactions. *Circulation Research* 97 (6), 512–523.
- Antoniades, H.N., Scher, C.D. and Stiles, C.D. (1979) Purification of human platelet-derived growth factor. *Proceedings of the National Academy of Sciences of the United States of America* 76 (4), 1809–1813.
- Arnold, T. and Betsholtz, C. (2013) The importance of microglia in the development of the vasculature in the central nervous system. *Vascular cell* 5 (1), 4.
- Arthur, J.S.C. and Ley, S.C. (2013) Mitogen-activated protein kinases in innate immunity. *Nature Reviews Immunology* 13 (9), 679–692.
- Arya, M., Shergill, I.S., Williamson, M., Gommersall, L., Arya, N. and Patel, H.R.H. (2005) Basic principles of real-time quantitative PCR. *Expert Review of Molecular Diagnostics* 5 (2), 209–219.
- Assoian, R.K. (1997) Anchorage-dependent cell cycle progression. *Journal of Cell Biology* 136 (1), 1–4.
- Backer, J.M., Myers Jr, M.G., Shoelson, S.E., Chin, D.J., Sun, X.J., Miralpeix, M., Hu, P., Margolis, B., Skolnik, E.Y., Schlessinger, J. and al., et (1992) Phosphatidylinositol 3'-kinase is activated by association with IRS-1 during insulin

- stimulation. *The EMBO journal* 11 (9), 3469–3479.
- Bader, A.G., Kang, S., Zhao, L. and Vogt, P.K. (2005) Oncogenic PI3K deregulates transcription and translation. *Nature Reviews Cancer* 5 (12), 921–929.
- Balasubramaniam, V., Le Cras, T.D., Ivy, D.D., Grover, T.R., Kinsella, J.P. and Abman, S.H. (2003) Role of platelet-derived growth factor in vascular remodeling during pulmonary hypertension in the ovine fetus. *American journal of physiology. Lung cellular and molecular physiology* 284 (5), L826-33.
- Ball, S.G., Shuttleworth, C.A. and Kielty, C.M. (2007) Vascular endothelial growth factor can signal through platelet-derived growth factor receptors. *Journal of Cell Biology* 177 (3), 489–500.
- Barkauskas, D.S., Dixon Dorand, R., Myers, J.T., Evans, T.A., Barkauskas, K.J., Askew, D., Purgert, R. and Huang, A.Y. (2015) Focal transient CNS vessel leak provides a tissue niche for sequential immune cell accumulation during the asymptomatic phase of EAE induction. *Experimental Neurology* 266, 74–85.
- Barr, R.K. and Bogoyevitch, M.A. (2001) The c-Jun N-terminal protein kinase family of mitogen-activated protein kinases (JNK MAPKs). *The international journal of biochemistry & cell biology* 33 (11), 1047–1063.
- Bayascas, J.R. and Alessi, D.R. (2005) Regulation of Akt/PKB Ser473 phosphorylation. *Molecular cell* 18 (2), 143–145.
- Bazan, N. (2012) Basic Neurochemistry: Molecular, Cellular, and Medical Aspects (8th Edition). Neuroinflammation, Chapter 34. .
- Bedard, K. and Krause, K.-H. (2007) The NOX Family of ROS-Generating NADPH Oxidases: Physiology and Pathophysiology. *Physiological Reviews* 87 (1), 245–313.
- Bellacosa, A., Chan, T.O., Ahmed, N.N., Datta, K., Malstrom, S., Stokoe, D., McCormick, F., Feng, J. and Tsichlis, P. (1998) Akt activation by growth factors is a multiple-step process: the role of the PH domain. *Oncogene* 17 (3), 313–325.
- Benjamin, L.E., Hemo, I. and Keshet, E. (1998) A plasticity window for blood vessel remodelling is defined by pericyte coverage of the preformed endothelial network and is regulated by PDGF-B and VEGF. *Development* 125 (9), 1591–1598.
- Bergsten, E., Uutela, M., Li, X., Pietras, K., Östman, A., Heldin, C.-H., Alitalo, K. and Eriksson, U. (2001) PDGF-D is a specific, protease-activated ligand for the PDGF  $\beta$ -receptor. *Nature Cell Biology* 3 (5), 512–516.
- Berti, A., Rigacci, S., Raugei, G., Degl'Innocenti, D. and Ramponi, G. (1994) Inhibition of cellular response to platelet-derived growth factor by low Mr phosphotyrosine protein phosphatase overexpression. *FEBS Letters* 349 (1), 7–12.
- Bessis, A., Béchade, C., Bernard, D. and Roumier, A. (2007) Microglial control of neuronal death and synaptic properties. *Glia* 55 (3), 233–238.
- Bethel-Brown, C., Yao, H., Hu, G. and Buch, S. (2012) Platelet-derived growth factor (PDGF)-BB-mediated induction of monocyte chemoattractant protein 1 in human astrocytes: implications for HIV-associated neuroinflammation. *Journal of neuroinflammation* 9, 262.



- Betsholtz, C. (2003) Biology of platelet-derived growth factors in development. *Birth Defects Research Part C: Embryo Today: Reviews* 69 (4), 272–285.
- Betsholtz, C. (2004) Insight into the physiological functions of PDGF through genetic studies in mice. *Cytokine & Growth Factor Reviews* 15 (4), 215–228.
- Betsholtz, C., Johnsson, A., Heldin, C.H., Westermark, B., Lind, P., Urdea, M.S., Eddy, R., Shows, T.B., Philpott, K., Mellor, A.L., Knott, T.J. and Scott, J. (1986) cDNA sequence and chromosomal localization of human platelet-derived growth factor A-chain and its expression in tumour cell lines. *Nature* 320 (6064), 695–699.
- Betsholtz, C., Karlsson, L. and Lindahl, P. (2001) Developmental roles of platelet-derived growth factors. *BioEssays* 23 (6), 494–507.
- Bhutto, I. and Luty, G. (2012) Understanding age-related macular degeneration (AMD): Relationships between the photoreceptor/retinal pigment epithelium/Bruch's membrane/choriocapillaris complex. *Molecular Aspects of Medicine* 33 (4), 295–317.
- Bi, W., Xiao, L., Jia, Y., Wu, J., Xie, Q., Ren, J., Ji, G. and Yuan, Z. (2010) c-Jun N-terminal kinase enhances MST1-mediated pro-apoptotic signaling through phosphorylation at serine 82. *The Journal of biological chemistry* 285 (9), 6259–6264.
- Bignami, A., Eng, L.F., Dahl, D. and Uyeda, C.T. (1972) Localization of the glial fibrillary acidic protein in astrocytes by immunofluorescence. *Brain Research* 43 (2), 429–435.
- Bioukar, E.B., Marricco, N.C., Zuo, D. and Larose, L. (1999) Serine phosphorylation of the ligand-activated beta-platelet-derived growth factor receptor by casein kinase I-gamma2 inhibits the receptor's autophosphorylating activity. *The Journal of biological chemistry* 274 (30), 21457–21463.
- Bishayee, S., Majumdar, S., Khire, J. and Das, M. (1989) Ligand-induced dimerization of the platelet-derived growth factor receptor. Monomer-dimer interconversion occurs independent of receptor phosphorylation. *The Journal of biological chemistry* 264 (20), 11699–11705.
- Blasi, E., Barluzzi, R., Bocchini, V., Mazzolla, R. and Bistoni, F. (1990) Immortalization of murine microglial cells by a v-raf / v-myc carrying retrovirus. *Journal of Neuroimmunology* 27 (2), 229–237.
- Block, M.L., Zecca, L. and Hong, J.-S. (2007) Microglia-mediated neurotoxicity: uncovering the molecular mechanisms. *Nature Reviews Neuroscience* 8 (1), 57–69.
- Blume-Jensen, P. and Hunter, T. (2001) Oncogenic kinase signalling. *Nature* 411 (6835), 355–365.
- Boche, D., Perry, V.H. and Nicoll, J.A.R. (2013) Review: activation patterns of microglia and their identification in the human brain. *Neuropathology and applied neurobiology* 39 (1), 3–18.
- Bogoyevitch, M.A. and Kobe, B. (2006) Uses for JNK: the many and varied substrates of the c-Jun N-terminal kinases. *Microbiology and molecular biology reviews: MMBR* 70 (4), 1061–1095.

- Bonita, D.P., Miyake, S., Lupper, M.L., Langdon, W.Y. and Band, H. (1997) Phosphotyrosine binding domain-dependent upregulation of the platelet-derived growth factor receptor alpha signaling cascade by transforming mutants of Cbl: implications for Cbl's function and oncogenicity. *Molecular and Cellular Biology* 17 (8), 4597–4610.
- Bonner, J.C. (2004) Regulation of PDGF and its receptors in fibrotic diseases. *Cytokine & Growth Factor Reviews* 15 (4), 255–273.
- Bork, P. and Beckmann, G. (1993) The CUB Domain: A Widespread Module in Developmentally Regulated Proteins. *Journal of Molecular Biology* 231 (2), 539–545.
- Borkham-Kamphorst, E., Meurer, S.K., Van de Leur, E., Haas, U., Tihaa, L. and Weiskirchen, R. (2015) PDGF-D signaling in portal myofibroblasts and hepatic stellate cells proves identical to PDGF-B via both PDGF receptor type  $\alpha$  and  $\beta$ . *Cellular Signalling* 27 (7), 1305–1314.
- Borkham-Kamphorst, E. and Weiskirchen, R. (2016) The PDGF system and its antagonists in liver fibrosis. *Cytokine & Growth Factor Reviews* 28, 53–61.
- Bornfeldt, K.E., Campbell, J.S., Koyama, H., Argast, G.M., Leslie, C.C., Raines, E.W., Krebs, E.G. and Ross, R. (1997) The mitogen-activated protein kinase pathway can mediate growth inhibition and proliferation in smooth muscle cells. Dependence on the availability of downstream targets. *The Journal of clinical investigation* 100 (4), 875–885.
- Boström, H., Gritli-Linde, A. and Betsholtz, C. (2002) PDGF- $\alpha$ /PDGF alpha-receptor signaling is required for lung growth and the formation of alveoli but not for early lung branching morphogenesis. *Developmental Dynamics* 223 (1), 155–162.
- Boström, H., Willetts, K., Pekny, M., Levéen, P., Lindahl, P., Hedstrand, H., Pekna, M., Hellström, M., Gebre-Medhin, S., Schalling, M., Nilsson, M., Kurland, S., Törnell, J., Heath, J.K. and Betsholtz, C. (1996) PDGF-A signaling is a critical event in lung alveolar myofibroblast development and alveogenesis. *Cell* 85 (6), 863–873.
- Boza-Serrano, A., Reyes, J.F., Rey, N.L., Leffler, H., Bousset, L., Nilsson, U., Brundin, P., Venero, J.L., Burguillos, M.A. and Deierborg, T. (2014) The role of Galectin-3 in  $\alpha$ -synuclein-induced microglial activation. *Acta neuropathologica communications* 2, 156.
- Bradley, J.R. and Pober, J.S. (2001) Tumor necrosis factor receptor-associated factors (TRAFs). *Oncogene* 20 (44), 6482–6491.
- Brognard, J., Sierrecki, E., Gao, T. and Newton, A.C. (2007) PHLPP and a second isoform, PHLPP2, differentially attenuate the amplitude of Akt signaling by regulating distinct Akt isoforms. *Molecular cell* 25 (6), 917–931.
- Brown, G.C. and Neher, J.J. (2010) Inflammatory Neurodegeneration and Mechanisms of Microglial Killing of Neurons. *Molecular Neurobiology* 41 (2), 242–247.
- Burgering, B.M.T. and Coffey, P.J. (1995) Protein kinase B (c-Akt) in phosphatidylinositol-3-OH kinase signal transduction. *Nature* 376 (6541), 599–

---

602.

- Butler, J.M. (2012) Chapter 3 - DNA Quantitation. 49–67.
- Butovsky, O., Jedrychowski, M.P., Moore, C.S., Cialic, R., Lanser, A.J., Gabriely, G., Koeglsperger, T., Dake, B., Wu, P.M., Doykan, C.E., Fanek, Z., Liu, L., Chen, Z., Rothstein, J.D., Ransohoff, R.M., Gygi, S.P., Antel, J.P. and Weiner, H.L. (2014) Identification of a unique TGF- $\beta$ -dependent molecular and functional signature in microglia. *Nature Neuroscience* 17 (1), 131–143.
- Butovsky, O. and Weiner, H.L. (2018) Microglial signatures and their role in health and disease. *Nature reviews. Neuroscience* 19 (10), 622–635.
- Campa, C., Costagliola, C., Incorvaia, C., Sheridan, C., Semeraro, F., De Nadai, K., Sebastiani, A. and Parmeggiani, F. (2010) Inflammatory mediators and angiogenic factors in choroidal neovascularization: pathogenetic interactions and therapeutic implications. *Mediators of inflammation* 2010, 546826.
- Camps, M., Nichols, A., Gillieron, C., Antonsson, B., Muda, M., Chabert, C., Boschert, U. and Arkinstall, S. (1998) Catalytic Activation of the Phosphatase MKP-3 by ERK2 Mitogen-Activated Protein Kinase. *Science* 280 (5367), 1262–1265.
- Canagarajah, B.J., Khokhlatchev, A., Cobb, M.H. and Goldsmith, E.J. (1997) Activation mechanism of the MAP kinase ERK2 by dual phosphorylation. *Cell* 90 (5), 859–869.
- Cantley, L.C. (2002) The Phosphoinositide 3-Kinase Pathway. *Science* 296 (5573), 1655–1657.
- Cantley, L.C. and Neel, B.G. (1999) New insights into tumor suppression: PTEN suppresses tumor formation by restraining the phosphoinositide 3-kinase/AKT pathway. *Proceedings of the National Academy of Sciences* 96 (8), 4240–4245.
- Cao, R., Bråkenhielm, E., Li, X., Pietras, K., Widenfalk, J., Östman, A., Eriksson, U. and Cao, Y. (2002) Angiogenesis stimulated by PDGF-CC, a novel member in the PDGF family, involves activation of PDGFR- $\alpha$  and - $\beta$  receptors. *The FASEB Journal* 1575–1583.
- Cargnello, M. and Roux, P.P. (2011) Activation and Function of the MAPKs and Their Substrates, the MAPK-Activated Protein Kinases. *Microbiology and Molecular Biology Reviews* 75 (1), 50–83.
- Carracedo, A. and Pandolfi, P.P. (2008) The PTEN-PI3K pathway: Of feedbacks and cross-talks. *Oncogene* 27 (41), 5527–5541.
- Carson, M. (2006) Microglia – The Professional Antigen-presenting Cells of the CNS? *Antigen Presenting Cells: From Mechanisms to Drug Development* 441–459.
- Carson, M.J., Crane, J. and Xie, A.X. (2008) Modeling CNS microglia: the quest to identify predictive models. *Drug discovery today. Disease models* 5 (1), 19–25.
- Chan, P.M., Ilangumaran, S., La Rose, J., Chakrabarty, A. and Rottapel, R. (2003) Autoinhibition of the kit receptor tyrosine kinase by the cytosolic juxtamembrane region. *Molecular and cellular biology* 23 (9), 3067–3078.
- Chan, W.Y., Kohsaka, S. and Rezaie, P. (2007) The origin and cell lineage of

- microglia—New concepts. *Brain Research Reviews* 53 (2), 344–354.
- Chao-Wei Chen, K., Zhou, Y., Xing, K., Krysan, K. and Lou, M.F. (2004) Platelet derived growth factor (PDGF)-induced reactive oxygen species in the lens epithelial cells: the redox signaling. *Experimental Eye Research* 78 (6), 1057–1067.
- Cheatham, B., Vlahos, C.J., Cheatham, L., Wang, L., Blenis, J. and Kahn, C.R. (1994) Phosphatidylinositol 3-kinase activation is required for insulin stimulation of pp70 S6 kinase, DNA synthesis, and glucose transporter translocation. *Molecular and cellular biology* 14 (7), 4902–4911.
- Checchin, D., Sennlaub, F., Levavasseur, E., Leduc, M. and Chemtob, S. (2006) Potential Role of Microglia in Retinal Blood Vessel Formation. *Investigative Ophthalmology & Visual Science* 47 (8), 3595–3602.
- Chen, J., Han, Y., Lin, C., Zhen, Y., Song, X., Teng, S., Chen, C., Chen, Y., Zhang, Y. and Hui, R. (2005) PDGF-D contributes to neointimal hyperplasia in rat model of vessel injury. *Biochemical and Biophysical Research Communications* 329 (3), 976–983.
- Chen, L., Yang, P. and Kijlstra, A. (2002) Distribution, markers, and functions of retinal microglia. *Ocular immunology and inflammation* 10 (1), 27–39.
- Chen, N.C., Partridge, A.T., Sell, C., Torres, C. and Martín-García, J. (2017) Fate of microglia during HIV-1 infection: From activation to senescence? *Glia* 65 (3), 431–446.
- Chen, P.-H., Chen, X. and He, X. (2013) Platelet-derived growth factors and their receptors: Structural and functional perspectives. *Biochimica et Biophysica Acta (BBA) - Proteins and Proteomics* 1834 (10), 2176–2186.
- Chen, W.-W., Zhang, X. and Huang, W.-J. (2016) Role of neuroinflammation in neurodegenerative diseases (Review). *Molecular medicine reports* 13 (4), 3391–3396.
- Chen, Z., Gibson, T.B., Robinson, F., Silvestro, L., Pearson, G., Xu, B., Wright, A., Vanderbilt, C. and Cobb, M.H. (2001) MAP kinases. *Chemical reviews* 101 (8), 2449–2476.
- Chiarugi, P., Cirri, P., Raugei, G., Camici, G., Dolfi, F., Berti, A. and Ramponi, G. (1995) PDGF receptor as a specific in vivo target for low Mr phosphotyrosine protein phosphatase. *FEBS Letters* 372 (1), 49–53.
- Chong, H. and Guan, K.L. (2003) Regulation of Raf through phosphorylation and N terminus-C terminus interaction. *Journal of Biological Chemistry* 278 (38), 36269–36276.
- Chopdar, A., Chakravarthy, U. and Verma, D. (2003) Age related macular degeneration. *BMJ* 326 (7387), 485–488.
- Choudhury, G.G., Ghosh-Choudhury, N. and Abboud, H.E. (1998) Association and direct activation of signal transducer and activator of transcription1alpha by platelet-derived growth factor receptor. *The Journal of clinical investigation* 101 (12), 2751–2760.

- Chung, J., Grammar, T.C., Lemon, K.P., Kazlauskas, A. and Blenis, J. (1994) PDGF- and insulin-dependent pp70S6k activation mediated by phosphatidylinositol-3-OH kinase. *Nature* 370 (6484), 71–75.
- Cianciulli, A., Porro, C., Calvello, R., Trotta, T., Lofrumento, D.D. and Panaro, M.A. (2020) Microglia Mediated Neuroinflammation: Focus on PI3K Modulation. *Biomolecules* 10 (1), 137.
- Claesson-Welsh, L., Eriksson, A., Westermark, B. and Heldin, C.H. (1989) cDNA cloning and expression of the human A-type platelet-derived growth factor (PDGF) receptor establishes structural similarity to the B-type PDGF receptor. *Proceedings of the National Academy of Sciences of the United States of America* 86 (13), 4917–4921.
- Clark, E.A. and Brugge, J.S. (1995) Integrins and signal transduction pathways: The road taken. *Science* 268 (5208), 233–239.
- Coats, S.R., Olashaw, N.E. and Pledger, W.J. (1994) Characterization of platelet-derived growth factor alpha receptor synthesis and metabolic turnover. *Cell growth & differentiation: the molecular biology journal of the American Association for Cancer Research* 5 (9), 937–942.
- Colton, C.A. (2009) Heterogeneity of Microglial Activation in the Innate Immune Response in the Brain. *Journal of Neuroimmune Pharmacology* 4 (4), 399–418.
- Combadière, C., Feumi, C., Raoul, W., Keller, N., Rodéro, M., Pézard, A., Lavalette, S., Houssier, M., Jonet, L., Picard, E., Debré, P., Sirinyan, M., Deterre, P., Ferroukhi, T., Cohen, S.-Y., Chauvaud, D., Jeanny, J.-C., Chemtob, S., Behar-Cohen, F. and Sennlaub, F. (2007) CX3CR1-dependent subretinal microglia cell accumulation is associated with cardinal features of age-related macular degeneration. *The Journal of clinical investigation* 117 (10), 2920–2928.
- Coulthard, L.R., White, D.E., Jones, D.L., McDermott, M.F. and Burchill, S.A. (2009) p38(MAPK): stress responses from molecular mechanisms to therapeutics. *Trends in molecular medicine* 15 (8), 369–379.
- Cousins, S.W., Espinosa-Heidmann, D.G. and Csaky, K.G. (2004) Monocyte Activation in Patients With Age-Related Macular Degeneration: A Biomarker of Risk for Choroidal Neovascularization? *Archives of Ophthalmology* 122 (7), 1013–1018.
- Cox, O.T., Simpson, D.A.C., Stitt, A.W. and Gardiner, T.A. (2003) Sources of PDGF expression in murine retina and the effect of short-term diabetes. *Molecular Vision* 9, 665–672.
- Craig, E.A., Stevens, M. V., Vaillancourt, R.R. and Camenisch, T.D. (2008) MAP3Ks as central regulators of cell fate during development. *Developmental Dynamics* 237 (11), 3102–3114.
- Cuadrado, A. and Nebreda, A.R. (2010) Mechanisms and functions of p38 MAPK signalling. *Biochemical Journal* 429 (3), 403–417.
- Cuadros, M.A., Martin, C., Coltey, P., Almendros, A. and Navascués, J. (1993) First appearance, distribution, and origin of macrophages in the early development of the avian central nervous system. *The Journal of comparative neurology* 330 (1),

113–129.

- Cuenda, A. and Rousseau, S. (2007) p38 MAP-Kinases pathway regulation, function and role in human diseases. *Biochimica et Biophysica Acta (BBA) - Molecular Cell Research* 1773 (8), 1358–1375.
- Cuevas, B.D., Abell, A.N. and Johnson, G.L. (2007) Role of mitogen-activated protein kinase kinase kinases in signal integration. *Oncogene* 26 (22), 3159–3171.
- Cui, J., Zhang, M., Zhang, Y.Q. and Xu, Z.H. (2007) JNK pathway: Diseases and therapeutic potential. *Acta Pharmacologica Sinica* 28 (5), 601–608.
- Cully, M., You, H., Levine, A.J. and Mak, T.W. (2006) Beyond PTEN mutations: the PI3K pathway as an integrator of multiple inputs during tumorigenesis. *Nature reviews. Cancer* 6 (3), 184–192.
- Cutler, R.E., Stephens, R.M., Saracino, M.R. and Morrison, D.K. (1998) Autoregulation of the Raf-1 serine/threonine kinase. *Proceedings of the National Academy of Sciences of the United States of America* 95 (16), 9214–9219.
- Czeh, M., Gressens, P. and Kaindl, A.M. (2011) The yin and yang of microglia. *Developmental neuroscience* 33 (3–4), 199–209.
- Dai, X., Li, N., Yu, L., Chen, Z., Hua, R., Qin, X. and Zhang, Y.-M. (2015) Activation of BV2 microglia by lipopolysaccharide triggers an inflammatory reaction in PC12 cell apoptosis through a toll-like receptor 4-dependent pathway. *Cell stress & chaperones* 20 (2), 321–331.
- Dalla-Favera, R., Gallo, R.C., Giallongo, A. and Croce, C.M. (1982) Chromosomal localization of the human homolog (c-sis) of the simian sarcoma virus onc gene. *Science* 218 (4573), 686–688.
- Dan, I., Watanabe, N.M. and Kusumi, A. (2001) The Ste20 group kinases as regulators of MAP kinase cascades. *Trends in Cell Biology* 11 (5), 220–230.
- Dance, M., Montagner, A., Salles, J.-P., Yart, A. and Raynal, P. (2008) The molecular functions of Shp2 in the Ras/Mitogen-activated protein kinase (ERK1/2) pathway. *Cellular Signalling* 20 (3), 453–459.
- Daniel, T.O., Gibbs, V.C., Milfay, D.F., Garovoy, M.R. and Williams, L.T. (1986) Thrombin stimulates c-sis gene expression in microvascular endothelial cells. *Journal of Biological Chemistry* 261 (21), 9579–9582.
- Darnell, J.E. (1997) STATs and Gene Regulation. *Science* 277 (5332), 1630–1635.
- Davalos, D., Grutzendler, J., Yang, G., Kim, J. V, Zuo, Y., Jung, S., Littman, D.R., Dustin, M.L. and Gan, W.-B. (2005) ATP mediates rapid microglial response to local brain injury in vivo. *Nature Neuroscience* 8 (6), 752–758.
- Davis, R.J. (1994) MAPKs: new JNK expands the group. *Trends in Biochemical Sciences* 19 (11), 470–473.
- Davis, R.J. (2000) Signal transduction by the JNK group of MAP kinases. *Cell* 103 (2), 239–252.
- Demoulin, J.-B. and Essagher, A. (2014) PDGF receptor signaling networks in normal and cancer cells. *Cytokine & Growth Factor Reviews* 25 (3), 273–283.

- Demoulin, J.-B., Seo, J.K., Ekman, S., Grapengiesser, E., Hellman, U., Rönstrand, L. and Heldin, C.-H. (2003) Ligand-induced recruitment of Na<sup>+</sup>/H<sup>+</sup>-exchanger regulatory factor to the PDGF (platelet-derived growth factor) receptor regulates actin cytoskeleton reorganization by PDGF. *The Biochemical journal* 376 (Pt 2), 505–510.
- Dhanasekaran, D.N. and Reddy, E.P. (2008) JNK signaling in apoptosis. *Oncogene* 27 (48), 6245–6251.
- Dhillon, N.K., Peng, F., Ransohoff, R.M. and Buch, S. (2007) PDGF Synergistically Enhances IFN- $\gamma$ -Induced Expression of CXCL10 in Blood-Derived Macrophages: Implications for HIV Dementia. *The Journal of Immunology* 179 (5), 2722–2730.
- Ding, H., Wu, X., Boström, H., Kim, I., Wong, N., Tsoi, B., O'Rourke, M., Koh, G.Y., Soriano, P., Betsholtz, C., Hart, T.C., Marazita, M.L., Field, L.L., Tam, P.P.L. and Nagy, A. (2004) A specific requirement for PDGF-C in palate formation and PDGFR- $\alpha$  signaling. *Nature Genetics* 36 (10), 1111–1116.
- Ding, X., Patel, M. and Chan, C.-C. (2009) Molecular pathology of age-related macular degeneration. *Progress in Retinal and Eye Research* 28 (1), 1–18.
- Distler, J.H.W., Jüngel, A., Huber, L.C., Schulze-Horsel, U., Zwerina, J., Gay, R.E., Michel, B.A., Hauser, T., Schett, G., Gay, S. and Distler, O. (2007) Imatinib mesylate reduces production of extracellular matrix and prevents development of experimental dermal fibrosis. *Arthritis and rheumatism* 56 (1), 311–322.
- Dong, C., Davis, R.J. and Flavell, R.A. (2002) MAP Kinases in the Immune Response. *Annual Review of Immunology* 20 (1), 55–72.
- Du, K., Herzig, S., Kulkarni, R.N. and Montminy, M. (2003) TRB3: a tribbles homolog that inhibits Akt/PKB activation by insulin in liver. *Science* 300 (5625), 1574–1577.
- Duan, D.S., Pazin, M.J., Fretto, L.J. and Williams, L.T. (1991) A functional soluble extracellular region of the platelet-derived growth factor (PDGF) beta-receptor antagonizes PDGF-stimulated responses. *The Journal of biological chemistry* 266 (1), 413–418.
- Eger, G. (2016) *Regulation and Function of MAP Kinases in PDGF Signaling (PhD dissertation)*. Uppsala. Retrieved from <http://urn.kb.se/resolve?urn=urn:nbn:se:uu:diva-301057>
- Eilken, H.M. and Adams, R.H. (2010) Dynamics of endothelial cell behavior in sprouting angiogenesis. *Current Opinion in Cell Biology* 22 (5), 617–625.
- Eitner, F., Bücher, E., van Roeyen, C., Kunter, U., Rong, S., Seikrit, C., Villa, L., Boor, P., Fredriksson, L., Bäckström, G., Eriksson, U., Ostman, A., Floege, J. and Ostendorf, T. (2008) PDGF-C is a proinflammatory cytokine that mediates renal interstitial fibrosis. *Journal of the American Society of Nephrology: JASN* 19 (2), 281–289.
- EIAlI, A. and Rivest, S. (2016) Microglia Ontology and Signaling. *Frontiers in cell and developmental biology* 4, 72.
- Elmore, M.R.P., Najafi, A.R., Koike, M.A., Dagher, N.N., Spangenberg, E.E., Rice, R.A., Kitazawa, M., Matusow, B., Nguyen, H., West, B.L. and Green, K.N. (2014) Colony-stimulating factor 1 receptor signaling is necessary for microglia viability,

- unmasking a microglia progenitor cell in the adult brain. *Neuron* 82 (2), 380–397.
- Engelman, J.A., Luo, J. and Cantley, L.C. (2006) The evolution of phosphatidylinositol 3-kinases as regulators of growth and metabolism. *Nature Reviews Genetics* 7 (8), 606–619.
- Erblich, B., Zhu, L., Etgen, A.M., Dobrenis, K. and Pollard, J.W. (2011) Absence of colony stimulation factor-1 receptor results in loss of microglia, disrupted brain development and olfactory deficits. *PLoS one* 6 (10), e26317.
- Erlandsson, A., Brännvall, K., Gustafsdóttir, S., Westermark, B. and Forsberg-Nilsson, K. (2006) Autocrine/Paracrine Platelet-Derived Growth Factor Regulates Proliferation of Neural Progenitor Cells. *Cancer Research* 66 (16), 8042–8048.
- Escobedo, J.A., Kaplan, D.R., Kavanaugh, W.M., Turck, C.W. and Williams, L.T. (1991) A phosphatidylinositol-3 kinase binds to platelet-derived growth factor receptors through a specific receptor sequence containing phosphotyrosine. *Molecular and cellular biology* 11 (2), 1125–1132.
- Esiri, M.M., al Izzi, M.S. and Reading, M.C. (1991) Macrophages, microglial cells, and HLA-DR antigens in fetal and infant brain. *Journal of clinical pathology* 44 (2), 102–106.
- Espinosa-Heidmann, D.G., Reinoso, M.A., Pina, Y., Csaky, K.G., Caicedo, A. and Cousins, S.W. (2005) Quantitative enumeration of vascular smooth muscle cells and endothelial cells derived from bone marrow precursors in experimental choroidal neovascularization. *Experimental Eye Research* 80 (3), 369–378.
- Fantl, W.J., Escobedo, J.A., Martin, G.A., Turck, C.W., del Rosario, M., McCormick, F. and Williams, L.T. (1992) Distinct phosphotyrosines on a growth factor receptor bind to specific molecules that mediate different signaling pathways. *Cell* 69 (3), 413–423.
- Fantl, W.J., Escobedo, J.A. and Williams, L.T. (1989) Mutations of the platelet-derived growth factor receptor that cause a loss of ligand-induced conformational change, subtle changes in kinase activity, and impaired ability to stimulate DNA synthesis. *Molecular and cellular biology* 9 (10), 4473–4478.
- Feng, J., Park, J., Cron, P., Hess, D. and Hemmings, B.A. (2004) Identification of a PKB/Akt hydrophobic motif Ser-473 kinase as DNA-dependent protein kinase. *The Journal of biological chemistry* 279 (39), 41189–41196.
- Feng, L., Zhou, X., Liao, J. and Omary, M.B. (1999) Pervanadate-mediated tyrosine phosphorylation of keratins 8 and 19 via a p38 mitogen-activated protein kinase-dependent pathway. *Journal of cell science* 112 (13), 2081–2090.
- Figuera-Losada, M., Rojas, C. and Slusher, B.S. (2014) Inhibition of microglia activation as a phenotypic assay in early drug discovery. *Journal of biomolecular screening* 19 (1), 17–31.
- Floege, J., Ostendorf, T., Janssen, U., Burg, M., Radeke, H.H., Vargeese, C., Gill, S.C., Green, L.S. and Janjic, N. (1999) Novel Approach to Specific Growth Factor Inhibition in Vivo: Antagonism of Platelet-Derived Growth Factor in Glomerulonephritis by Aptamers. *The American Journal of Pathology* 154 (1), 169–179.



- Fourgeaud, L., Través, P.G., Tufail, Y., Leal-Bailey, H., Lew, E.D., Burrola, P.G., Callaway, P., Zagórska, A., Rothlin, C. V, Nimmerjahn, A. and Lemke, G. (2016) TAM receptors regulate multiple features of microglial physiology. *Nature* 532 (7598), 240–244.
- Frank-Cannon, T.C., Alto, L.T., McAlpine, F.E. and Tansey, M.G. (2009) Does neuroinflammation fan the flame in neurodegenerative diseases? *Molecular neurodegeneration* 4, 47.
- Franke, T.F., Yang, S. II, Chan, T.O., Datta, K., Kazlauskas, A., Morrison, D.K., Kaplan, D.R. and Tsichlis, P.N. (1995) The protein kinase encoded by the Akt proto-oncogene is a target of the PDGF-activated phosphatidylinositol 3-kinase. *Cell* 81 (5), 727–736.
- Fredriksson, L., Li, H. and Eriksson, U. (2004) The PDGF family: four gene products form five dimeric isoforms. *Cytokine & Growth Factor Reviews* 15 (4), 197–204.
- Freter, R.R., Alberta, J.A., Hwang, G.Y., Wrentmore, A.L. and Stiles, C.D. (1996) Platelet-derived growth factor induction of the immediate-early gene MCP-1 is mediated by NF-kappaB and a 90-kDa phosphoprotein coactivator. *The Journal of biological chemistry* 271 (29), 17417–17424.
- Fretto, L.J., Snape, A.J., Tomlinson, J.E., Seroogy, J.J., Wolf, D.L., LaRochelle, W.J. and Giese, N.A. (1993) Mechanism of platelet-derived growth factor (PDGF) AA, AB, and BB binding to alpha and beta PDGF receptor. *The Journal of biological chemistry* 268 (5), 3625–3631.
- Frisch, S.M. and Ruoslahti, E. (1997) Integrins and anoikis. *Current Opinion in Cell Biology* 9 (5), 701–706.
- Fruman, D.A., Chiu, H., Hopkins, B.D., Bagrodia, S., Cantley, L.C. and Abraham, R.T. (2017) The PI3K Pathway in Human Disease. *Cell* 170 (4), 605–635.
- Fruman, D.A., Meyers, R.E. and Cantley, L.C. (1998) Phosphoinositide kinases. *Annual Review of Biochemistry* 67 (1), 481–507.
- Fruttiger, M., Karlsson, L., Hall, A.C., Abramsson, A., Calver, A.R., Bostrom, H., Willetts, K., Bertold, C.H., Heath, J.K., Betsholtz, C. and Richardson, W.D. (1999) Defective oligodendrocyte development and severe hypomyelination in PDGF-A knockout mice. *Development* 126 (3), 457–467.
- Fu, R., Shen, Q., Xu, P., Luo, J.J. and Tang, Y. (2014) Phagocytosis of Microglia in the Central Nervous System Diseases. *Molecular Neurobiology* 49 (3), 1422–1434.
- Fu, X.-J., Peng, Y.-B., Hu, Y.-P., Shi, Y.-Z., Yao, M. and Zhang, X. (2014) NADPH oxidase 1 and its derived reactive oxygen species mediated tissue injury and repair. *Oxidative medicine and cellular longevity* 2014, 282854.
- Fuhrmann, M., Bittner, T., Jung, C.K.E., Burgold, S., Page, R.M., Mitteregger, G., Haass, C., LaFerla, F.M., Kretschmar, H. and Herms, J. (2010) Microglial Cx3cr1 knockout prevents neuron loss in a mouse model of Alzheimer's disease. *Nature Neuroscience* 13 (4), 411–413.
- Fujita, N., Sato, S., Katayama, K. and Tsuruo, T. (2002) Akt-dependent phosphorylation of p27Kip1 promotes binding to 14-3-3 and cytoplasmic

- localization. *Journal of Biological Chemistry* 277 (32), 28706–28713.
- Fukai, T. and Ushio-Fukai, M. (2011) Superoxide dismutases: role in redox signaling, vascular function, and diseases. *Antioxidants & redox signaling* 15 (6), 1583–1606.
- Fukunaga, R. and Hunter, T. (1997) MNK1, a new MAP kinase-activated protein kinase, isolated by a novel expression screening method for identifying protein kinase substrates. *The EMBO journal* 16 (8), 1921–1933.
- Gagelin, C., Pierre, M. and Torudelbauffe, D. (1994) Inhibition of G1 Cyclin Expression and G1 Cyclin-Dependent Protein-Kinases by cAMP in an Astrocytic Cell Line. *Biochemical and Biophysical Research Communications* 205 (1), 923–929.
- Gao, F., Chen, D., Hu, Q. and Wang, G. (2013) Rotenone directly induces BV2 cell activation via the p38 MAPK pathway. *PLoS one* 8 (8), e72046.
- Gao, H.-M. and Hong, J.-S. (2008) Why neurodegenerative diseases are progressive: uncontrolled inflammation drives disease progression. *Trends in immunology* 29 (8), 357–365.
- Gao, T., Furnari, F. and Newton, A.C. (2005) PHLPP: A Phosphatase that Directly Dephosphorylates Akt, Promotes Apoptosis, and Suppresses Tumor Growth. *Molecular Cell* 18 (1), 13–24.
- Gavrilov, K. and Saltzman, W.M. (2012) Therapeutic siRNA: principles, challenges, and strategies. *The Yale journal of biology and medicine* 85 (2), 187–200.
- Ge, B., Gram, H., Di Padova, F., Huang, B., New, L., Ulevitch, R.J., Luo, Y. and Han, J. (2002) MAPKK-Independent Activation of p38 $\alpha$  Mediated by TAB1-Dependent Autophosphorylation of p38 $\alpha$ . *Science* 295 (5558), 1291–1294.
- Gertig, U. and Hanisch, U.-K. (2014) Microglial diversity by responses and responders. *Frontiers in cellular neuroscience* 8, 101.
- Gilbertson, D.G., Duff, M.E., West, J.W., Kelly, J.D., Sheppard, P.O., Hofstrand, P.D., Gao, Z., Shoemaker, K., Bukowski, T.R., Moore, M., Feldhaus, A.L., Humes, J.M., Palmer, T.E. and Hart, C.E. (2001) Platelet-derived Growth Factor C (PDGF-C), a Novel Growth Factor that Binds to PDGF  $\alpha$  and  $\beta$  Receptor. *Journal of Biological Chemistry* 27406–27414.
- Gills, J., Castillo, S., Zhang, C., Petukhov, P., Memmott, R., Hollingshead, M., Warfel, N., Han, J., Kozikowski, A. and Dennis, P. (2007) Phosphatidylinositol Ether Lipid Analogues That Inhibit AKT Also Independently Activate the Stress Kinase, p38, through MKK3/6-independent and -dependent Mechanisms. *The Journal of biological chemistry* 282 (37), 27020–27029.
- Ginhoux, F., Greter, M., Leboeuf, M., Nandi, S., See, P., Gokhan, S., Mehler, M.F., Conway, S.J., Ng, L.G., Stanley, E.R., Samokhvalov, I.M. and Merad, M. (2010) Fate Mapping Analysis Reveals That Adult Microglia Derive from Primitive Macrophages. *Science* 330 (6005), 841–845.
- Giulian, D. and Baker, T.J. (1986) Characterization of ameboid microglia isolated from developing mammalian brain. *The Journal of neuroscience : the official journal of the Society for Neuroscience* 6 (8), 2163–2178.

- Glass, C.K., Saijo, K., Winner, B., Marchetto, M.C. and Gage, F.H. (2010) Mechanisms underlying inflammation in neurodegeneration. *Cell* 140 (6), 918–934.
- Goedert, M., Cuenda, A., Craxton, M., Jakes, R. and Cohen, P. (1997) Activation of the novel stress-activated protein kinase SAPK4 by cytokines and cellular stresses is mediated by SKK3 (MKK6); comparison of its substrate specificity with that of other SAP kinases. *The EMBO journal* 16 (12), 3563–3571.
- Gomez-Nicola, D. and Perry, V.H. (2015) Microglial dynamics and role in the healthy and diseased brain: a paradigm of functional plasticity. *The Neuroscientist: a review journal bringing neurobiology, neurology and psychiatry* 21 (2), 169–184.
- Gomez Perdiguero, E., Klapproth, K., Schulz, C., Busch, K., Azzoni, E., Crozet, L., Garner, H., Trouillet, C., de Bruijn, M.F., Geissmann, F. and Rodewald, H.-R. (2015) Tissue-resident macrophages originate from yolk-sac-derived erythro-myeloid progenitors. *Nature* 518 (7540), 547–551.
- Gomez Perdiguero, E., Schulz, C. and Geissmann, F. (2013) Development and homeostasis of “resident” myeloid cells: The case of the microglia. *Glia* 61 (1), 112–120.
- Graves, L.E.E.M., Bornfeldtt, K.E., Argast, G.M., Krebs, E.G., Kongt, X., Lint, T.A.I.A.N. and Lawrence, J.C. (1995) cAMP- and rapamycin-sensitive regulation of the association of eukaryotic initiation factor 4E and the translational regulator PHAS-I in aortic smooth muscle cells. *Proceedings of the National Academy of Sciences of the United States of America* 92 (16), 7222–7226.
- Graves, L.M., Bornfeldt, K.E., Sidhu, J.S., Argast, G.M., Raines, E.W., Ross, R., Leslie, C.C. and Krebs, E.G. (1996) Platelet-derived growth factor stimulates protein kinase A through a mitogen-activated protein kinase-dependent pathway in human arterial smooth muscle cells. *The Journal of biological chemistry* 271 (1), 505–511.
- Gresa-Arribas, N., Viéitez, C., Dentesano, G., Serratos, J., Saura, J. and Solà, C. (2012) Modelling neuroinflammation in vitro: a tool to test the potential neuroprotective effect of anti-inflammatory agents. *PloS one* 7 (9), e45227–e45227.
- Greter, M., Lelios, I., Pelczar, P., Hoeffel, G., Price, J., Leboeuf, M., Kündig, T.M., Frei, K., Ginhoux, F., Merad, M. and Becher, B. (2012) Stroma-derived interleukin-34 controls the development and maintenance of langerhans cells and the maintenance of microglia. *Immunity* 37 (6), 1050–1060.
- Greter, M. and Merad, M. (2013) Regulation of microglia development and homeostasis. *Glia* 61 (1), 121–127.
- Griciuc, A., Serrano-Pozo, A., Parrado, A.R., Lesinski, A.N., Asselin, C.N., Mullin, K., Hooli, B., Choi, S.H., Hyman, B.T. and Tanzi, R.E. (2013) Alzheimer’s disease risk gene CD33 inhibits microglial uptake of amyloid beta. *Neuron* 78 (4), 631–643.
- Griffith, J., Black, J., Faerman, C., Swenson, L., Wynn, M., Lu, F., Lippke, J., Saxena, K. and Street, W. (2004) The Structural Basis for Autoinhibition of FLT3 by the Juxtamembrane Domain. *Molecular cell* 13 (2), 169–178.

- Grossniklaus, H., Ling, J., Wallace, T., Dithmar, S., Lawson, D., Cohen, C., Elner, V., Elner, S. and Sternberg, P. (2002) Macrophage and retinal pigment epithelium expression of angiogenic cytokines in choroidal neovascularization. *Molecular vision* 8, 119–126.
- Grossniklaus, H.E. and Green, W.R. (2004) Choroidal neovascularization. *American Journal of Ophthalmology* 137 (3), 496–503.
- Gupta, N., Brown, K.E. and Milam, A.H. (2003) Activated microglia in human retinitis pigmentosa, late-onset retinal degeneration, and age-related macular degeneration. *Experimental Eye Research* 76 (4), 463–471.
- Haeusgen, W., Boehm, R., Zhao, Y., Herdegen, T. and Waetzig, V. (2009) Specific activities of individual c-Jun N-terminal kinases in the brain. *Neuroscience* 161 (4), 951–959.
- Haglund, K., Di Fiore, P.P. and Dikic, I. (2003) Distinct monoubiquitin signals in receptor endocytosis. *Trends in Biochemical Sciences* 28 (11), 598–604.
- Hammond, S.M., Boettcher, S., Caudy, A.A., Kobayashi, R. and Hannon, G.J. (2001) Argonaute2, a Link Between Genetic and Biochemical Analyses of RNAi. *Science* 293 (5532), 1146–1150.
- Han, J., Lee, J.D., Bibbs, L. and Ulevitch, R.J. (1994) A MAP kinase targeted by endotoxin and hyperosmolarity in mammalian cells. *Science* 265 (5173), 808–811.
- Han, J., Lee, J.D., Tobias, P.S. and Ulevitch, R.J. (1993) Endotoxin induces rapid protein tyrosine phosphorylation in 70Z/3 cells expressing CD14. *The Journal of biological chemistry* 268 (33), 25009–25014.
- Hanada, M., Feng, J. and Hemmings, B.A. (2004) Structure, regulation and function of PKB/AKT—a major therapeutic target. *Biochimica et Biophysica Acta (BBA) - Proteins and Proteomics* 1697 (1), 3–16.
- Hanisch, U.-K. (2013a) Functional diversity of microglia - how heterogeneous are they to begin with? *Frontiers in cellular neuroscience* 7, 65.
- Hanisch, U.-K. (2013b) Proteins in microglial activation--inputs and outputs by subsets. *Current protein & peptide science* 14 (1), 3–15.
- Hanisch, U.-K. and Kettenmann, H. (2007) Microglia: active sensor and versatile effector cells in the normal and pathologic brain. *Nature Neuroscience* 10 (11), 1387–1394.
- Hanks, S.K. and Hunter, T. (1995) Protein kinases 6. The eukaryotic protein kinase superfamily: kinase (catalytic) domain structure and classification. *FASEB journal: official publication of the Federation of American Societies for Experimental Biology* 9 (8), 576–596.
- Hansen, K., Johnell, M., Siegbahn, A., Rorsman, C., Engstrom, U., Wernstedt, C., Heldin, C. and Ronnstrand, L. (1996) Mutation of a Src phosphorylation site in the PDGF p-receptor leads to increased PDGF-stimulated chemotaxis but decreased mitogenesis. *The EMBO journal* 15 (19), 5299–5313.
- Harlan, J.M., Thompson, P.J., Ross, R.R. and Bowen-Pope, D.F. (1986) Alpha-

- thrombin induces release of platelet-derived growth factor-like molecule(s) by cultured human endothelial cells. *The Journal of cell biology* 103 (3), 1129–1133.
- Hart, C.E., Forstrom, J.W., Kelly, J.D., Seifert, R.A., Smith, R.A., Ross, R., Murray, M.J. and Bowen-Pope, D.F. (1988) Two classes of PDGF receptor recognize different isoforms of PDGF. *Science* 240 (4858), 1529–1531.
- Hart, I.A.N.K., Richardson, W.D., Heldin, C., Westermark, B. and Raff, M.C. (1989) PDGF receptors on cells of the oligodendrocyte-type-2 astrocyte (O-2A) cell lineage. *Development* 603 (3), 595–603.
- Haslund-Vinding, J., McBean, G., Jaquet, V. and Vilhardt, F. (2017) NADPH oxidases in oxidant production by microglia: activating receptors, pharmacology and association with disease. *British journal of pharmacology* 174 (12), 1733–1749.
- Hawkins, P.T., Eguinoa, A., Qiu, R.G., Stokoe, D., Cooke, F.T., Walters, R., Wennström, S., Claesson-Welsh, L., Evans, T. and Symons, M. (1995) PDGF stimulates an increase in GTP-Rac via activation of phosphoinositide 3-kinase. *Current biology : CB* 5 (4), 393–403.
- Haynes, S.E., Hollopeter, G., Yang, G., Kurpius, D., Dailey, M.E., Gan, W.-B. and Julius, D. (2006) The P2Y<sub>12</sub> receptor regulates microglial activation by extracellular nucleotides. *Nature Neuroscience* 9 (12), 1512–1519.
- He, C., Medley, S.C., Hu, T., Hinsdale, M.E., Lupu, F., Virmani, R. and Olson, L.E. (2015) PDGFR $\beta$  signalling regulates local inflammation and synergizes with hypercholesterolaemia to promote atherosclerosis. *Nature Communications* 6 (1), 7770.
- Healy, L.M., Perron, G., Won, S.-Y., Michell-Robinson, M.A., Rezk, A., Ludwin, S.K., Moore, C.S., Hall, J.A., Bar-Or, A. and Antel, J.P. (2016) MerTK Is a Functional Regulator of Myelin Phagocytosis by Human Myeloid Cells. *Journal of immunology* 196 (8), 3375–3384.
- Heidaran, M.A., Pierce, J.H., Jensen, R.A., Matsui, T. and Aaronson, S.A. (1990) Chimeric alpha- and beta-platelet-derived growth factor (PDGF) receptors define three immunoglobulin-like domains of the alpha-PDGF receptor that determine PDGF-AA binding specificity. *The Journal of biological chemistry* 265 (31), 18741–18744.
- Heldin, C.-H., Eriksson, U. and Östman, A. (2002) New Members of the Platelet-Derived Growth Factor Family of Mitogens. *Archives of Biochemistry and Biophysics* 398 (2), 284–290.
- Heldin, C.-H. and Lennartsson, J. (2013) Structural and functional properties of platelet-derived growth factor and stem cell factor receptors. *Cold Spring Harbor perspectives in biology* 5 (8), a009100.
- Heldin, C.-H., Östman, A. and Rönstrand, L. (1998) Signal transduction via platelet-derived growth factor receptors. *Biochimica et Biophysica Acta (BBA) - Reviews on Cancer* 1378 (1), F79–F113.
- Heldin, C.-H. and Westermark, B. (1999) Mechanism of Action and In Vivo Role of Platelet-Derived Growth Factor. *Physiological Reviews* 79 (4), 1283–1316.
- Heldin, C.H., Ernlund, A., Rorsman, C. and Rönstrand, L. (1989) Dimerization of B-

- type platelet-derived growth factor receptors occurs after ligand binding and is closely associated with receptor kinase activation. *The Journal of biological chemistry* 264 (15), 8905–8912.
- Heldin, C.H., Johnsson, A., Wennergren, S., Wernstedt, C., Betsholtz, C. and Westermark, B. (1986) A human osteosarcoma cell line secretes a growth factor structurally related to a homodimer of PDGF A-chains. *Nature* 319 (6053), 511–514.
- Heldin, C.H. and Ostman, A. (1996) Ligand-induced dimerization of growth factor receptors: variations on the theme. *Cytokine & growth factor reviews* 7 (1), 3–10.
- Heldin, C.H., Wasteson, A. and Westermark, B. (1982) Interaction of platelet-derived growth factor with its fibroblast receptor. Demonstration of ligand degradation and receptor modulation. *The Journal of biological chemistry* 257 (8), 4216–4221.
- Heldin, P., Pertoft, H., Nordlinder, H., Heldin, C.H. and Laurent, T.C. (1991) Differential expression of platelet-derived growth factor alpha- and beta- receptors on fat-storing cells and endothelial cells of rat liver. *Experimental cell research* 193 (2), 364–369.
- Hellberg, C., Schmees, C., Karlsson, S., Ahgren, A. and Heldin, C.-H. (2009) Activation of protein kinase C alpha is necessary for sorting the PDGF beta-receptor to Rab4a-dependent recycling. *Molecular biology of the cell* 20 (12), 2856–2863.
- Hellstrom, M., Kaln, M., Lindahl, P., Abramsson, A. and Betsholtz, C. (1999) Role of PDGF-B and PDGFR-beta in recruitment of vascular smooth muscle cells and pericytes during embryonic blood vessel formation in the mouse. *Development* 126 (14), 3047–3055.
- Hemmings, B.A. and Restuccia, D.F. (2012) PI3K-PKB/Akt pathway. *Cold Spring Harbor perspectives in biology* 4 (9), a011189–a011189.
- Heneka, M.T., Kummer, M.P. and Latz, E. (2014) Innate immune activation in neurodegenerative disease. *Nature reviews. Immunology* 14 (7), 463–477.
- Heppner, F.L., Ransohoff, R.M. and Becher, B. (2015) Immune attack: the role of inflammation in Alzheimer disease. *Nature Reviews Neuroscience* 16 (6), 358–372.
- Herbomel, P., Thisse, B. and Thisse, C. (2001) Zebrafish Early Macrophages Colonize Cephalic Mesenchyme and Developing Brain, Retina, and Epidermis through a M-CSF Receptor-Dependent Invasive Process. *Developmental Biology* 238 (2), 274–288.
- Hermanson, M., Funa, K., Hartman, M., Claesson-Welsh, L., Heldin, C.H., Westermark, B. and Nistér, M. (1992) Platelet-derived growth factor and its receptors in human glioma tissue: expression of messenger RNA and protein suggests the presence of autocrine and paracrine loops. *Cancer research* 52 (11), 3213–3219.
- Herren, B., Rooney, B., Weyer, K.A., Iberg, N., Schmid, G. and Pech, M. (1993) Dimerization of extracellular domains of platelet-derived growth factor receptors. A revised model of receptor-ligand interaction. *The Journal of biological chemistry*

268 (20), 15088–15095.

- Hers, I., Vincent, E.E. and Tavaré, J.M. (2011) Akt signalling in health and disease. *Cellular Signalling* 23 (10), 1515–1527.
- Heuchel, R., Berg, A., Tallquist, M., Ahlén, K., Reed, R.K., Rubin, K., Claesson-Welsh, L., Heldin, C.H. and Soriano, P. (1999) Platelet-derived growth factor beta receptor regulates interstitial fluid homeostasis through phosphatidylinositol-3' kinase signaling. *Proceedings of the National Academy of Sciences of the United States of America* 96 (20), 11410–11415.
- Hibi, M., Lin, A., Smeal, T., Minden, A. and Karin, M. (1993) Identification of an oncoprotein- and UV-responsive protein kinase that binds and potentiates the c-Jun activation domain. *Genes & development* 7 (11), 2135–2148.
- Hickman, S., Izzy, S., Sen, P., Morsett, L. and El Khoury, J. (2018) Microglia in neurodegeneration. *Nature neuroscience* 21 (10), 1359–1369.
- Hickman, S.E., Allison, E.K. and El Khoury, J. (2008) Microglial dysfunction and defective beta-amyloid clearance pathways in aging Alzheimer's disease mice. *The Journal of neuroscience : the official journal of the Society for Neuroscience* 28 (33), 8354–8360.
- Hickman, S.E., Kingery, N.D., Ohsumi, T.K., Borowsky, M.L., Wang, L., Means, T.K. and El Khoury, J. (2013) The microglial sensome revealed by direct RNA sequencing. *Nature Neuroscience* 16 (12), 1896–1905.
- Hideto, S., Tetsuo, S., Masayuki, Y., Toshinori, M., Hiroshi, K., Nobuyuki, T., Satomi, N., Shin-Ichi, N. and Toru, K. (2001) Functional Blockade of Platelet-Derived Growth Factor Receptor- $\beta$  but Not of Receptor- $\alpha$  Prevents Vascular Smooth Muscle Cell Accumulation in Fibrous Cap Lesions in Apolipoprotein E-Deficient Mice. *Circulation* 103 (24), 2955–2960.
- Hildreth, K.L., Wu, J.-H., Barak, L.S., Exum, S.T., Kim, L.K., Peppel, K. and Freedman, N.J. (2004) Phosphorylation of the platelet-derived growth factor receptor-beta by G protein-coupled receptor kinase-2 reduces receptor signaling and interaction with the Na(+)/H(+) exchanger regulatory factor. *The Journal of biological chemistry* 279 (40), 41775–41782.
- Hirrlinger, J., Gutterer, J.M., Kussmaul, L., Hamprecht, B. and Dringen, R. (2000) Microglial cells in culture express a prominent glutathione system for the defense against reactive oxygen species. *Developmental neuroscience* 22 (5–6), 384–392.
- Hoch, R. V and Soriano, P. (2003) Roles of PDGF in animal development. *Development* 130 (20), 4769–4784.
- Höglund, K. and Salter, H. (2013) Molecular biomarkers of neurodegeneration. *Expert review of molecular diagnostics* 13 (8), 845–861.
- Holland, P.M., Abramson, R.D., Watson, R. and Gelfand, D.H. (1991) Detection of specific polymerase chain reaction product by utilizing the 5'----3' exonuclease activity of *Thermus aquaticus* DNA polymerase. *Proceedings of the National Academy of Sciences of the United States of America* 88 (16), 7276–7280.
- Hoyle, G.W., Li, J., Finkelstein, J.B., Eisenberg, T., Liu, J.Y., Lasky, J.A., Athas, G.,

- Morris, G.F. and Brody, A.R. (1999) Emphysematous lesions, inflammation, and fibrosis in the lungs of transgenic mice overexpressing platelet-derived growth factor. *The American journal of pathology* 154 (6), 1763–1775.
- Hu, Q., Klippel, A., Muslin, A.J., Fantl, W.J. and Williams, L.T. (1995) Ras-dependent induction of cellular responses by constitutively active phosphatidylinositol-3 kinase. *Science* 268 (5207), 100–102.
- Huang, G., Shi, L.Z. and Chi, H. (2009) Regulation of JNK and p38 MAPK in the immune system: signal integration, propagation and termination. *Cytokine* 48 (3), 161–169.
- Huang, H., Parlier, R., Shen, J.-K., Luttly, G.A. and Viores, S.A. (2013) VEGF receptor blockade markedly reduces retinal microglia/macrophage infiltration into laser-induced CNV. *PloS one* 8 (8), e71808.
- Hubbard, S.R. (2004) Juxtamembrane autoinhibition in receptor tyrosine kinases. *Nature Reviews Molecular Cell Biology* 5 (6), 464–471.
- Humbert, M., Monti, G., Fartoukh, M., Magnan, A., Brenot, F., Rain, B., Capron, F., Galanaud, P., Duroux, P., Simonneau, G. and Emilie, D. (1998) Platelet-derived growth factor expression in primary pulmonary hypertension: comparison of HIV seropositive and HIV seronegative patients. *The European respiratory journal* 11 (3), 554–559.
- Hutchins, K.D., Dickson, D.W., Rashbaum, W.K. and Lyman, W.D. (1990) Localization of morphologically distinct microglial populations in the developing human fetal brain: implications for ontogeny. *Developmental Brain Research* 55 (1), 95–102.
- Imai, Y., Ibata, I., Ito, D., Ohsawa, K. and Kohsaka, S. (1996) A Novel Geneiba1 in the Major Histocompatibility Complex Class III Region Encoding an EF Hand Protein Expressed in a Monocytic Lineage. *Biochemical and Biophysical Research Communications* 224 (3), 855–862.
- Inoue, K. (2002) Microglial activation by purines and pyrimidines. *Glia* 40 (2), 156–163.
- Ip, Y.T. and Davis, R.J. (1998) Signal transduction by the c-Jun N-terminal kinase (JNK) — from inflammation to development. *Current Opinion in Cell Biology* 10 (2), 205–219.
- Izumi-Nagai, K., Nagai, N., Ohgami, K., Satofuka, S., Ozawa, Y., Tsubota, K., Ohno, S., Oike, Y. and Ishida, S. (2008) Inhibition of choroidal neovascularization with an anti-inflammatory carotenoid astaxanthin. *Investigative ophthalmology & visual science* 49 (4), 1679–1685.
- Jackson, A.L., Bartz, S.R., Schelter, J., Kobayashi, S. V, Burchard, J., Mao, M., Li, B., Cavet, G. and Linsley, P.S. (2003) Expression profiling reveals off-target gene regulation by RNAi. *Nature Biotechnology* 21 (6), 635–637.
- James, M.F., Beauchamp, R.L., Manchanda, N., Kazlauskas, A. and Ramesh, V. (2004) A NHERF binding site links the  $\beta$ PDGFR to the cytoskeleton and regulates cell spreading and migration. *Journal of Cell Science* 2951–2961.
- Jiang, Y., Chen, C., Li, Z., Guo, W., Gegner, J.A., Lin, S. and Han, J. (1996) Characterization of the structure and function of a new mitogen-activated protein



- kinase (p38beta). *The Journal of biological chemistry* 271 (30), 17920–17926.
- Jiang, Y., Gram, H., Zhao, M., New, L., Gu, J., Feng, L., Di Padova, F., Ulevitch, R.J. and Han, J. (1997) Characterization of the structure and function of the fourth member of p38 group mitogen-activated protein kinases, p38delta. *The Journal of biological chemistry* 272 (48), 30122–30128.
- Jo, N., Mailhos, C., Ju, M., Cheung, E., Bradley, J., Nishijima, K., Robinson, G.S., Adamis, A.P. and Shima, D.T. (2006) Inhibition of platelet-derived growth factor B signaling enhances the efficacy of anti-vascular endothelial growth factor therapy in multiple models of ocular neovascularization. *The American journal of pathology* 168 (6), 2036–2053.
- Joazeiro, C.A.P., Wing, S.S., Huang, H., Levenson, J.D., Hunter, T. and Liu, Y.-C. (1999) The Tyrosine Kinase Negative Regulator c-Cbl as a RING-Type, E2-Dependent Ubiquitin-Protein Ligase. *Science* 286 (5438), 309–312.
- Johnson, G.L. and Lapadat, R. (2002) Mitogen-activated protein kinase pathways mediated by ERK, JNK, and p38 protein kinases. *Science* 298 (5600), 1911–1912.
- Johnson, G.L. and Nakamura, K. (2007) The c-jun kinase/stress-activated pathway: regulation, function and role in human disease. *Biochimica et biophysica acta* 1773 (8), 1341–1348.
- Johnson, R.J., Raines, E.W., Floege, J., Yoshimura, A., Pritzl, P., Alpers, C. and Ross, R. (1992) Inhibition of mesangial cell proliferation and matrix expansion in glomerulonephritis in the rat by antibody to platelet-derived growth factor. *The Journal of experimental medicine* 175 (5), 1413–1416.
- Joly, M., Kazlauskas, A., Fay, F.S. and Corvera, S. (1994) Disruption of PDGF receptor trafficking by mutation of its PI-3 kinase binding sites. *Science* 263 (5147), 684–687.
- Jurek, A., Heldin, C. and Lennartsson, J. (2011) Platelet-derived growth factor-induced signaling pathways interconnect to regulate the temporal pattern of Erk1 / 2 phosphorylation. *Cellular Signalling* 23 (1), 280–287.
- Kang, S.W. (2007) Two axes in platelet-derived growth factor signaling: tyrosine phosphorylation and reactive oxygen species. *Cellular and Molecular Life Sciences* 64 (5), 533–541.
- Kardas, G., Daszyńska-Kardas, A., Marynowski, M., Brząkalska, O., Kuna, P. and Panek, M. (2020) Role of Platelet-Derived Growth Factor (PDGF) in Asthma as an Immunoregulatory Factor Mediating Airway Remodeling and Possible Pharmacological Target. *Frontiers in pharmacology* 11, 47.
- Karlsson, L., Bondjers, C. and Betsholtz, C. (1999) Roles for PDGF-A and sonic hedgehog in development of mesenchymal components of the hair follicle. *Development* 126 (12), 2611–2621.
- Karlsson, L., Lindahl, P., Heath, J.K. and Betsholtz, C. (2000) Abnormal gastrointestinal development in PDGF-A and PDGFR-(alpha) deficient mice implicates a novel mesenchymal structure with putative instructive properties in villus morphogenesis. *Development* 127 (16), 3457–3466.

- Karlsson, S., Kowanetz, K., Sandin, A., Persson, C., Ostman, A., Heldin, C.-H. and Hellberg, C. (2006) Loss of T-cell protein tyrosine phosphatase induces recycling of the platelet-derived growth factor (PDGF) beta-receptor but not the PDGF alpha-receptor. *Molecular biology of the cell* 17 (11), 4846–4855.
- Karlstetter, M., Nothdurfter, C., Aslanidis, A., Moeller, K., Horn, F., Scholz, R., Neumann, H., Weber, B.H.F., Rupprecht, R. and Langmann, T. (2014) Translocator protein (18 kDa) (TSPO) is expressed in reactive retinal microglia and modulates microglial inflammation and phagocytosis. *Journal of neuroinflammation* 11 (1), 3.
- Karlstetter, M., Scholz, R., Rutar, M., Wong, W.T., Provis, J.M. and Langmann, T. (2015) Retinal microglia: Just bystander or target for therapy? *Progress in Retinal and Eye Research* 45, 30–57.
- Karvinen, H., Rutanen, J., Leppänen, O., Lach, R., Levonen, A.-L., Eriksson, U. and Ylä-Herttuala, S. (2009) PDGF-C and -D and their receptors PDGFR- $\alpha$  and PDGFR- $\beta$  in atherosclerotic human arteries. *European Journal of Clinical Investigation* 39 (4), 320–327.
- Kashishian, A., Kazlauskas, A. and Cooper, J.A. (1992) Phosphorylation sites in the PDGF receptor with different specificities for binding GAP and PI3 kinase in vivo. *The EMBO journal* 11 (4), 1373–1382.
- Kato, J.Y., Matsuoka, M., Polyak, K., Massagué, J. and Sherr, C.J. (1994) Cyclic AMP-induced G1 phase arrest mediated by an inhibitor (p27Kip1) of cyclin-dependent kinase 4 activation. *Cell* 79 (3), 487–496.
- Katso, R., Okkenhaug, K., Ahmadi, K., White, S., Timms, J. and Waterfield, M.D. (2001) Cellular Function of Phosphoinositide 3-Kinases: Implications for Development, Immunity, Homeostasis, and Cancer. *Annual Review of Cell and Developmental Biology* 17 (1), 615–675.
- Kavanaugh, W.M., Turck, C.W., Klippel, A. and Williams, L.T. (1994) Tyrosine 508 of the 85-kilodalton subunit of phosphatidylinositol 3-kinase is phosphorylated by the platelet-derived growth factor receptor. *Biochemistry* 33 (36), 11046–11050.
- Kawada, K., Upadhyay, G., Ferandon, S., Janarthanan, S., Hall, M., Vilaradaga, J.-P. and Yajnik, V. (2009) Cell migration is regulated by platelet-derived growth factor receptor endocytosis. *Molecular and cellular biology* 29 (16), 4508–4518.
- Kazlauskas, A. (2017) PDGFs and their receptors. *Gene* 614, 1–7.
- Kazlauskas, A. and Cooper, J.A. (1989) Autophosphorylation of the PDGF receptor in the kinase insert region regulates interactions with cell proteins. *Cell* 58 (6), 1121–1133.
- Kazlauskas, A. and Cooper, J.A. (1990) Phosphorylation of the PDGF receptor, B subunit creates a tight binding site for phosphatidylinositol 3 kinase. *Cell* 9 (10), 3279–3286.
- Kazlauskas, A., Durden, D.L. and Cooper, J.A. (1991) Functions of the major tyrosine phosphorylation site of the PDGF receptor beta subunit. *Cell regulation* 2 (6), 413–425.
- Kazlauskas, A., Kashishian, A., Cooper, J.A. and Valius, M. (1992) GTPase-activating

- protein and phosphatidylinositol 3-kinase bind to distinct regions of the platelet-derived growth factor receptor beta subunit. *Molecular and cellular biology* 12 (6), 2534–2544.
- Kelly, J.D., Haldeman, B.A., Grant, F.J., Murray, M.J., Seifert, R.A., Bowen-Pope, D.F., Cooper, J.A. and Kazlauskas, A. (1991) Platelet-derived Growth Factor (PDGF) Stimulates PDGF Receptor Subunit Dimerization and Intersubunit. *The Journal of biological chemistry* 266 (14), 8987–8992.
- Kettenmann, H., Hanisch, U.-K., Noda, M. and Verkhratsky, A. (2011) Physiology of Microglia. *Physiological Reviews* 91 (2), 461–553.
- Keyse, S.M. (2000) Protein phosphatases and the regulation of mitogen-activated protein kinase signalling. *Current Opinion in Cell Biology* 12 (2), 186–192.
- Khosravi-Far, R., Soliski, P.A., Clark, G.J., Kinch, M.S. and Der, C.J. (1995) Activation of Rac1, RhoA, and mitogen-activated protein kinases is required for Ras transformation. *Molecular and cellular biology* 15 (11), 6443–6453.
- El Khoury, J., Toft, M., Hickman, S.E., Means, T.K., Terada, K., Geula, C. and Luster, A.D. (2007) Ccr2 deficiency impairs microglial accumulation and accelerates progression of Alzheimer-like disease. *Nature Medicine* 13 (4), 432–438.
- El Khoury, J.B., Moore, K.J., Means, T.K., Leung, J., Terada, K., Toft, M., Freeman, M.W. and Luster, A.D. (2003) CD36 mediates the innate host response to beta-amyloid. *The Journal of experimental medicine* 197 (12), 1657–1666.
- Kierdorf, K., Erny, D., Goldmann, T., Sander, V., Schulz, C., Perdiguero, E.G., Wieghofer, P., Heinrich, A., Riemke, P., Hölscher, C., Müller, D.N., Luckow, B., Bocker, T., Debowski, K., Fritz, G., Opdenakker, G., Diefenbach, A., Biber, K., Heikenwalder, M., Geissmann, F., Rosenbauer, F. and Prinz, M. (2013) Microglia emerge from erythromyeloid precursors via Pu.1- and Irf8-dependent pathways. *Nature Neuroscience* 16 (3), 273–280.
- Killingsworth, M.C. (1995) Angiogenesis in early choroidal neovascularization secondary to age-related macular degeneration. *Graefe's archive for clinical and experimental ophthalmology = Albrecht von Graefes Archiv fur klinische und experimentelle Ophthalmologie* 233 (6), 313–323.
- Kim, E.K. and Choi, E.-J. (2010) Pathological roles of MAPK signaling pathways in human diseases. *Biochimica et biophysica acta* 1802 (4), 396–405.
- Kim, L. and Wong, T.A.I.W.A.I. (1995) The Cytoplasmic Tyrosine Kinase FER Is Associated with the Catenin-Like Substrate pp120 and Is Activated by Growth Factors. *Molecular and cellular biology* 15 (8), 4553–4561.
- Kim, S.U. and de Vellis, J. (2005) Microglia in health and disease. *Journal of Neuroscience Research* 81 (3), 302–313.
- Kim, Sang-Hoon, Kim, Sang-Heon, Lee, J.-H., Lee, B.-H., Yoon, H.J., Shin, D.H., Park, S.S., Jang, S. Bin, Park, J.-S. and Jee, Y.-K. (2015) Superoxide Dismutase Gene (SOD1, SOD2, and SOD3) Polymorphisms and Antituberculosis Drug-induced Hepatitis. *Allergy, asthma & immunology research* 7 (1), 88–91.
- Kishi, M., Aono, Y., Sato, S., Koyama, K., Azuma, M., Abe, S., Kawano, H., Kishi, J., Toyoda, Y., Okazaki, H., Ogawa, H., Uehara, H. and Nishioka, Y. (2018) Blockade

- of platelet-derived growth factor receptor- $\beta$ , not receptor- $\alpha$  ameliorates bleomycin-induced pulmonary fibrosis in mice. *PLoS one* 13 (12), e0209786–e0209786.
- Klinghoffer, R.A., Duckworth, B., Valius, M., Cantley, L. and Kazlauskas, A. (1996) Platelet-derived growth factor-dependent activation of phosphatidylinositol 3-kinase is regulated by receptor binding of SH2-domain-containing proteins which influence Ras activity. *Molecular and cellular biology* 16 (10), 5905–5914.
- Klippel, A., Kavanaugh, W.M., Pot, D. and Williams, L.T. (1997) A specific product of phosphatidylinositol 3-kinase directly activates the protein kinase Akt through its pleckstrin homology domain. *Molecular and cellular biology* 17 (1), 338–344.
- Kourembanas, S., Morita, T., Liu, Y. and Christou, H. (1997) Mechanisms by which oxygen regulates gene expression and cell-cell interaction in the vasculature. *Kidney International* 51 (2), 438–443.
- Kraft, A.D. and Harry, G.J. (2011) Features of microglia and neuroinflammation relevant to environmental exposure and neurotoxicity. *International journal of environmental research and public health* 8 (7), 2980–3018.
- Krasemann, S., Madore, C., Cialic, R., Baufeld, C., Calcagno, N., El Fatimy, R., Beckers, L., O’Loughlin, E., Xu, Y., Fanek, Z., Greco, D.J., Smith, S.T., Tweet, G., Humulock, Z., Zrzavy, T., Conde-Sanroman, P., Gacias, M., Weng, Z., Chen, H., Tjon, E., Mazaheri, F., Hartmann, K., Madi, A., Ulrich, J.D., Glatzel, M., Worthmann, A., Heeren, J., Budnik, B., Lemere, C., Ikezu, T., Heppner, F.L., Litvak, V., Holtzman, D.M., Lassmann, H., Weiner, H.L., Ochando, J., Haass, C. and Butovsky, O. (2017) The TREM2-APOE Pathway Drives the Transcriptional Phenotype of Dysfunctional Microglia in Neurodegenerative Diseases. *Immunity* 47 (3), 566-581.e9.
- Krause, T.A., Alex, A.F., Engel, D.R., Kurts, C. and Eter, N. (2014) VEGF-production by CCR2-dependent macrophages contributes to laser-induced choroidal neovascularization. *PLoS one* 9 (4), e94313–e94313.
- Kreutzberg, G.W. (1996) Microglia: a sensor for pathological events in the CNS. *Trends in neurosciences* 19 (8), 312–318.
- Kreuzer, J., Viedt, C., Brandes, R.P., Seeger, F., Rosenkranz, A.S., Sauer, H., Babich, A., Nürnberg, B., Kather, H. and Krieger-Brauer, H.I. (2003) Platelet-derived growth factor activates production of reactive oxygen species by NAD(P)H-oxidase in smooth muscle cells through Gi1,2. *The FASEB Journal* 17 (1), 38–40.
- Krieger-Brauer, H.I. and Kather, H. (1995) Antagonistic effects of different members of the fibroblast and platelet-derived growth factor families on adipose conversion and NADPH-dependent H<sub>2</sub>O<sub>2</sub> generation in 3T3 L1-cells. *The Biochemical journal* 307, 549–556.
- Kubota, Y., Takubo, K., Shimizu, T., Ohno, H., Kishi, K., Shibuya, M., Saya, H. and Suda, T. (2009) M-CSF inhibition selectively targets pathological angiogenesis and lymphangiogenesis. *The Journal of experimental medicine* 206 (5), 1089–1102.
- Kudelka, M.R., Grossniklaus, H.E. and Mandell, K.J. (2013) Emergence of dual VEGF and PDGF antagonists in the treatment of exudative age-related macular

- degeneration. *Expert review of ophthalmology* 8 (5), 475–484.
- Kumar, S., McDonnell, P.C., Gum, R.J., Hand, A.T., Lee, J.C. and Young, P.R. (1997) Novel Homologues of CSBP/p38 MAP Kinase: Activation, Substrate Specificity and Sensitivity to Inhibition by Pyridinyl Imidazoles. *Biochemical and Biophysical Research Communications* 235 (3), 533–538.
- Kurz, H. and Christ, B. (1998) Embryonic CNS macrophages and microglia do not stem from circulating, but from extravascular precursors. *Glia* 22 (1), 98–102.
- Kusuhara, M., Takahashi, E., Peterson, T.E., Abe, J., Ishida, M., Han, J., Ulevitch, R. and Berk, B.C. (1998) p38 Kinase is a negative regulator of angiotensin II signal transduction in vascular smooth muscle cells: effects on Na<sup>+</sup>/H<sup>+</sup> exchange and ERK1/2. *Circulation research* 83 (8), 824–831.
- Kyriakis, J.M. and Avruch, J. (2012) Mammalian MAPK signal transduction pathways activated by stress and inflammation: A 10-year update. *Physiological Reviews* 92 (2), 689–737.
- Kyriakis, J.M. and Avruch, J. (2001) Mammalian mitogen-activated protein kinase signal transduction pathways activated by stress and inflammation. *Physiological Reviews* 81 (2), 807–869.
- Kyriakis, J.M. and Avruch, J. (1990) pp54 microtubule-associated protein 2 kinase. A novel serine/threonine protein kinase regulated by phosphorylation and stimulated by poly-L-lysine. *The Journal of biological chemistry* 265 (28), 17355–17363.
- Kyriakis, J.M., Banerjee, P., Nikolakaki, E., Dai, T., Rubie, E.A., Ahmad, M.F., Avruch, J. and Woodgett, J.R. (1994) The stress-activated protein kinase subfamily of c-Jun kinases. *Nature* 369 (6476), 156–160.
- Lambert, V., Lecomte, J., Hansen, S., Blacher, S., Gonzalez, M.-L.A., Struman, I., Sounni, N.E., Rozet, E., de Tullio, P., Foidart, J.M., Rakic, J.-M. and Noel, A. (2013) Laser-induced choroidal neovascularization model to study age-related macular degeneration in mice. *Nature protocols* 8 (11), 2197–2211.
- Langmann, T. (2007) Microglia activation in retinal degeneration. *Journal of leukocyte biology* 81 (6), 1345–1351.
- Larochelle, W.J., Jeffers, M., McDonald, W.F., Chillakuru, R.A., Giese, N.A., Lokker, N.A., Sullivan, C., Boldog, F.L., Yang, M., Vernet, C., Burgess, C.E., Fernandes, E., Deegler, L.L., Rittman, B., Shimkets, J., Shimkets, R.A., Rothberg, J.M. and Lichenstein, H.S. (2001) PDGF-D, a new protease-activated growth factor. *Nature cell biology* 3 (5), 517–521.
- Lawson, L.J., Perry, V.H., Dri, P. and Gordon, S. (1990) Heterogeneity in the distribution and morphology of microglia in the normal adult mouse brain. *Neuroscience* 39 (1), 151–170.
- Lawson, L.J., Perry, V.H. and Gordon, S. (1992) Turnover of resident microglia in the normal adult mouse brain. *Neuroscience* 48 (2), 405–415.
- Lechleider, R.J., Sugimoto, S., Bennett, A.M., Kashishian, A.S., Cooper, J.A., Shoelson, S.E., Walsh, C.T. and Neel, B.G. (1993) Activation of the SH2-containing phosphotyrosine phosphatase SH-PTP2 by its binding site,

- phosphotyrosine 1009, on the human platelet-derived growth factor receptor. *The Journal of biological chemistry* 268 (29), 21478–21481.
- Lechner, C., Zahalka, M.A., Giot, J., Mller, N.P.H. and Ullricht, A. (1996) ERK6, a mitogen-activated protein kinase involved in C2C12 myoblast differentiation. *Proceedings of the National Academy of Sciences* 93 (9), 4355–4359.
- Lee, H.S., Han, J., Bai, H.-J. and Kim, K.-W. (2009) Brain angiogenesis in developmental and pathological processes: regulation, molecular and cellular communication at the neurovascular interface. *The FEBS journal* 276 (17), England: 4622–4635.
- Lee, J.C., Laydon, J.T., McDonnell, P.C., Gallagher, T.F., Kumar, S., Green, D., McNulty, D., Blumenthal, M.J., Keys, J.R., Land vatter, S.W., Strickler, J.E., McLaughlin, M.M., Siemens, I.R., Fisher, S.M., Livi, G.P., White, J.R., Adams, J.L. and Young, P.R. (1994) A protein kinase involved in the regulation of inflammatory cytokine biosynthesis. *Nature* 372 (6508), 739–746.
- Lee, Y., Kim, Y.J., Kim, M. and Kwak, J.M. (2016) MAPK Cascades in Guard Cell Signal Transduction. *Frontiers in plant science* 7, 80.
- LeGrand, E.K. (1998) Preclinical promise of becaplermin (rhPDGF-BB) in wound healing. *The American Journal of Surgery* 176 (2, Supplement 1), 48S-54S.
- Lei, H. and Kazlauskas, A. (2008) Focus on molecules: platelet-derived growth factor C, PDGF-C. *Experimental eye research* 86 (5), 711–712.
- Lei, H., Velez, G., Hovland, P., Hirose, T. and Kazlauskas, A. (2008) Plasmin is the major protease responsible for processing PDGF-C in the vitreous of patients with proliferative vitreoretinopathy. *Investigative Ophthalmology and Visual Science* 49 (1), 42–48.
- Lemmon, M.A. and Schlessinger, J. (2010) Cell Signaling by Receptor Tyrosine Kinases. *Cell* 141 (7), 1117–1134.
- Lennartsson, J., Wardega, P., Engstro, U., Hellman, U., Heldin, C. and Down-regulation, A.M.P. (2006) Alix facilitates the interaction between c-Cbl and platelet-derived growth factor beta-receptor and thereby modulates receptor down-regulation. *The Journal of biological chemistry* 281 (51), 39152–39158.
- Levéen, P., Pekny, M., Gebre-Medhin, S., Swolin, B., Larsson, E. and Betsholtz, C. (1994) Mice deficient for PDGF B show renal, cardiovascular, and hematological abnormalities. *Genes & development* 8 (16), 1875–1887.
- Li, D.M. and Sun, H. (1997) TEP1, encoded by a candidate tumor suppressor locus, is a novel protein tyrosine phosphatase regulated by transforming growth factor beta. *Cancer research* 57 (11), 2124–2129.
- Li, L., Heiduschka, P., Alex, A.F., Niekämper, D. and Eter, N. (2017) Behaviour of CD11b-Positive Cells in an Animal Model of Laser-Induced Choroidal Neovascularisation. *Ophthalmologica. Journal internationale d'ophtalmologie. International journal of ophthalmology. Zeitschrift fur Augenheilkunde* 237 (1), 29–41.
- Li, M., Jendrossek, V. and Belka, C. (2007) The role of PDGF in radiation oncology. *Radiation oncology* 2, 5.

- Li, X. and Eriksson, U. (2003) Novel PDGF family members: PDGF-C and PDGF-D. *Cytokine & Growth Factor Reviews* 14 (2), 91–98.
- Li, X., Pontén, A., Aase, K., Karlsson, L., Abramsson, A., Uutela, M., Bäckström, G., Hellström, M., Boström, H., Li, H., Soriano, P., Betsholtz, C., Heldin, C.-H., Alitalo, K., Östman, A. and Eriksson, U. (2000) PDGF-C is a new protease-activated ligand for the PDGF  $\alpha$ -receptor. *Nature Cell Biology* 2 (5), 302–309.
- Li, Z., Jiang, Y., Ulevitch, R.J. and Han, J. (1996) The Primary Structure of p38 $\gamma$ : A New Member of p38 Group of MAP Kinases. *Biochemical and Biophysical Research Communications* 228 (2), 334–340.
- Liddel, S.A., Guttenplan, K.A., Clarke, L.E., Bennett, F.C., Bohlen, C.J., Schirmer, L., Bennett, M.L., Münch, A.E., Chung, W.-S., Peterson, T.C., Wilton, D.K., Frouin, A., Napier, B.A., Panicker, N., Kumar, M., Buckwalter, M.S., Rowitch, D.H., Dawson, V.L., Dawson, T.M., Stevens, B. and Barres, B.A. (2017) Neurotoxic reactive astrocytes are induced by activated microglia. *Nature* 541 (7638), 481–487.
- Lim, L.S., Mitchell, P., Seddon, J.M., Holz, F.G. and Wong, T.Y. (2012) Age-related macular degeneration. *The Lancet* 379 (9827), 1728–1738.
- Lin, X., Ruan, X., Anderson, M.G., McDowell, J.A., Kroeger, P.E., Fesik, S.W. and Shen, Y. (2005) siRNA-mediated off-target gene silencing triggered by a 7 nt complementation. *Nucleic acids research* 33 (14), 4527–4535.
- Lindahl, P., Johansson, B.R., Levéen, P. and Betsholtz, C. (1997) Pericyte loss and microaneurysm formation in PDGF-B-deficient mice. *Science* 277 (5323), 242–245.
- Liu, J., Copland, D.A., Horie, S., Wu, W.-K., Chen, M., Xu, Y., Paul Morgan, B., Mack, M., Xu, H., Nicholson, L.B. and Dick, A.D. (2013) Myeloid cells expressing VEGF and arginase-1 following uptake of damaged retinal pigment epithelium suggests potential mechanism that drives the onset of choroidal angiogenesis in mice. *PloS one* 8 (8), e72935.
- Liu, P., Cheng, H., Roberts, T.M. and Zhao, J.J. (2009) Targeting the phosphoinositide 3-kinase pathway in cancer. *Nature Reviews Drug Discovery* 8 (8), 627–644.
- Liu, P., Ying, Y., Ko, Y.G. and Anderson, R.G. (1996) Localization of platelet-derived growth factor-stimulated phosphorylation cascade to caveolae. *The Journal of biological chemistry* 271 (17), 10299–10303.
- Liu, Y., Shepherd, E.G. and Nelin, L.D. (2007) MAPK phosphatases - Regulating the immune response. *Nature Reviews Immunology* 7 (3), 202–212.
- Liu, Z. and Cao, W. (2009) p38 mitogen-activated protein kinase: a critical node linking insulin resistance and cardiovascular diseases in type 2 diabetes mellitus. *Endocrine, metabolic & immune disorders drug targets* 9 (1), 38–46.
- Livak, K.J. and Schmittgen, T.D. (2001) Analysis of Relative Gene Expression Data Using Real-Time Quantitative PCR and the  $2^{-\Delta\Delta CT}$  Method. *Methods* 25 (4), 402–408.
- Lloyd, A.C. (2006) Distinct functions for ERKs? *Journal of Biology* 5 (5), 13.

- Loesch, M. and Chen, G. (2008) The p38 MAPK stress pathway as a tumor suppressor or more? *Frontiers in bioscience : a journal and virtual library* 13, 3581–3593.
- Lokker, N.A., Hare, J.P.O., Barsoumian, A., Tomlinson, J.E., Ramakrishnan, V., Fretto, L.J. and Giese, N.A. (1997) Functional importance of platelet-derived growth factor (PDGF) receptor extracellular immunoglobulin-like domains. Identification of PDGF binding site and neutralizing monoclonal antibodies. *The Journal of biological chemistry* 272 (52), 33037–33044.
- Lokker, N.A., Sullivan, C.M., Hollenbach, S.J., Israel, M.A. and Giese, N.A. (2002) Platelet-derived Growth Factor (PDGF) Autocrine Signaling Regulates Survival and Mitogenic Pathways in Glioblastoma Cells. *Cancer Research* 62 (13), 3729–3735.
- London, A., Cohen, M. and Schwartz, M. (2013) Microglia and monocyte-derived macrophages: functionally distinct populations that act in concert in CNS plasticity and repair. *Frontiers in cellular neuroscience* 7, 34.
- Lopez-Illasaca, M., Li, W., Uren, A., Yu, J., Kazlauskas, A., Gutkind, J.S. and Heidaran, M.A. (1997) Requirement of Phosphatidylinositol-3 Kinase for Activation of JNK/SAPKs by PDGF. *Biochemical and Biophysical Research Communications* 232 (2), 273–277.
- Lu, Y.-Z., Lin, C.-H., Cheng, F.-C. and Hsueh, C.-M. (2005) Molecular mechanisms responsible for microglia-derived protection of Sprague–Dawley rat brain cells during in vitro ischemia. *Neuroscience Letters* 373 (2), 159–164.
- Ludwig, S., Engel, K., Hoffmeyer, A., Sithanandam, G., Neufeld, B., Palm, D., Gaestel, M., Rapp, U.L.F.R., Lloyd, P.A., Bader, S., Sekido, Y., Tartof, K.D., Kashuba, V.I., Zabarovsky, E.R., Dean, M., Klein, G., Zbar, B., Lerman, M.I., Minna, J.D., Rapp, U.R., Allikmets, A., Biol, M.C., Al, L.E.T. and Iol, M.O.L.C.E.L.L.B. (1996) 3pK, a novel mitogen-activated protein (MAP) kinase-activated protein kinase, is targeted by three MAP kinase pathways. *Molecular and cellular biology* 16 (12), 6687–6697.
- Lui, H., Zhang, J., Makinson, S.R., Cahill, M.K., Kelley, K.W., Huang, H.-Y., Shang, Y., Oldham, M.C., Martens, L.H., Gao, F., Coppola, G., Sloan, S.A., Hsieh, C.L., Kim, C.C., Bigio, E.H., Weintraub, S., Mesulam, M.-M., Rademakers, R., Mackenzie, I.R., Seeley, W.W., Karydas, A., Miller, B.L., Borroni, B., Ghidoni, R., Faresse, R.V.J., Paz, J.T., Barres, B.A. and Huang, E.J. (2016) Progranulin Deficiency Promotes Circuit-Specific Synaptic Pruning by Microglia via Complement Activation. *Cell* 165 (4), 921–935.
- Lull, M.E. and Block, M.L. (2010) Microglial activation and chronic neurodegeneration. *Neurotherapeutics: the journal of the American Society for Experimental NeuroTherapeutics* 7 (4), 354–365.
- Luo, X.-G. and Chen, S.-D. (2012) The changing phenotype of microglia from homeostasis to disease. *Translational neurodegeneration* 1 (1), 9.
- Lyck, L., Santamaria, I.D., Pakkenberg, B., Chemnitz, J., Schrøder, H.D., Finsen, B. and Gundersen, H.J.G. (2009) An empirical analysis of the precision of estimating the numbers of neurons and glia in human neocortex using a fractionator-design with sub-sampling. *Journal of Neuroscience Methods* 182 (2), 143–156.



- Maehama, T. and Dixon, J.E. (1998) The tumor suppressor, PTEN/MMAC1, dephosphorylates the lipid second messenger, phosphatidylinositol 3,4,5-trisphosphate. *The Journal of biological chemistry* 273 (22), 13375–13378.
- Mahimainathan, L. and Choudhury, G.G. (2004) Inactivation of platelet-derived growth factor receptor by the tumor suppressor PTEN provides a novel mechanism of action of the phosphatase. *The Journal of biological chemistry* 279 (15), 15258–15268.
- Mahon, E.S., Hawrysh, A.D., Chagpar, R.B., Johnson, L.M. and Anderson, D.H. (2005) A-Raf associates with and regulates platelet-derived growth factor receptor signalling. *Cellular signalling* 17 (7), 857–868.
- Maira, S.M., Galetic, I., Brazil, D.P., Kaech, S., Ingley, E., Thelen, M. and Hemmings, B.A. (2001) Carboxyl-terminal modulator protein (CTMP), a negative regulator of PKB/Akt and v-Akt at the plasma membrane. *Science* 294 (5541), 374–380.
- Manning, B.D. and Cantley, L.C. (2007) AKT/PKB signaling: navigating downstream. *Cell* 129 (7), 1261–1274.
- Manzat Saplacan, R.M., Balacescu, L., Gherman, C., Chira, R.I., Craiu, A., Mircea, P.A., Lisencu, C. and Balacescu, O. A Macciò (editor), (2017) The Role of PDGFs and PDGFRs in Colorectal Cancer. *Mediators of Inflammation* 2017, 4708076.
- Marklund, S.L. (1984) Extracellular superoxide dismutase and other superoxide dismutase isoenzymes in tissues from nine mammalian species. *The Biochemical journal* 222 (3), 649–655.
- Marshall, C.J. (1995) Specificity of receptor tyrosine kinase signaling: Transient versus sustained extracellular signal-regulated kinase activation. *Cell* 80 (2), 179–185.
- Marumo, T., Schini-Kerth, V.B., Fisslthaler, B. and Busse, R. (1997) Platelet-derived growth factor-stimulated superoxide anion production modulates activation of transcription factor NF-kappaB and expression of monocyte chemoattractant protein 1 in human aortic smooth muscle cells. *Circulation* 96 (7), 2361–2367.
- Maruyama, J., Naguro, I., Takeda, K. and Ichijo, H. (2009) Stress-activated MAP kinase cascades in cellular senescence. *Current medicinal chemistry* 16 (10), 1229–1235.
- Matcovitch-Natan, O., Winter, D.R., Giladi, A., Vargas Aguilar, S., Spinrad, A., Sarrazin, S., Ben-Yehuda, H., David, E., Zelada González, F., Perrin, P., Keren-Shaul, H., Gury, M., Lara-Astaiso, D., Thaïss, C.A., Cohen, M., Bahar Halpern, K., Baruch, K., Deczkowska, A., Lorenzo-Vivas, E., Itzkovitz, S., Elinav, E., Sieweke, M.H., Schwartz, M. and Amit, I. (2016) Microglia development follows a stepwise program to regulate brain homeostasis. *Science* 353 (6301), aad8670.
- Matranga, C., Tomari, Y., Shin, C., Bartel, D.P. and Zamore, P.D. (2005) Passenger-Strand Cleavage Facilitates Assembly of siRNA into Ago2-Containing RNAi Enzyme Complexes. *Cell* 123 (4), 607–620.
- Matsui, T., Heidarani, Mohammad, Miki, T., Popescu, N., Rochelle, W. La, Kraus, Matthias, Pierce, J., Aaronson, S., Matsui, T., Heidarani, Mohamaiad, Miki, T., Popescu, N., Rochelle, W.L.A., Kraus, Matrhas, Pierce, J. and Aaronson, S. (1989) Isolation of a novel receptor cDNA establishes the existence of two PDGF

- receptor genes. *Science* 243 (4892), 800–804.
- Matsumoto, J., Dohgu, S., Takata, F., Nishioku, T., Sumi, N., Machida, T., Takahashi, H., Yamauchi, A. and Kataoka, Y. (2012) Lipopolysaccharide-activated microglia lower P-glycoprotein function in brain microvascular endothelial cells. *Neuroscience Letters* 524 (1), 45–48.
- Maudsley, S., Zamah, A.M., Rahman, N., Blitzer, J.T., Luttrell, L.M., Lefkowitz, R.J. and Hall, R.A. (2000) Platelet-derived growth factor receptor association with Na(+)/H(+) exchanger regulatory factor potentiates receptor activity. *Molecular and cellular biology* 20 (22), 8352–8363.
- Maxwell, M., Naber, S.P., Wolfe, H.J., Galanopoulos, T., Hedley-Whyte, E.T., Black, P.M. and Antoniades, H.N. (1990) Coexpression of platelet-derived growth factor (PDGF) and PDGF-receptor genes by primary human astrocytomas may contribute to their development and maintenance. *The Journal of clinical investigation* 86 (1), 131–140.
- McKay, M.M. and Morrison, D.K. (2007) Integrating signals from RTKs to ERK/MAPK. *Oncogene* 26 (22), 3113–3121.
- McKercher, S.R., Torbett, B.E., Anderson, K.L., Henkel, G.W., Vestal, D.J., Baribault, H., Klemsz, M., Feeney, A.J., Wu, G.E., Paige, C.J. and Maki, R.A. (1996) Targeted disruption of the PU.1 gene results in multiple hematopoietic abnormalities. *The EMBO journal* 15 (20), 5647–5658.
- McLeod, D.S., Bhutto, I., Edwards, M.M., Silver, R.E., Seddon, J.M. and Luty, G.A. (2016) Distribution and Quantification of Choroidal Macrophages in Human Eyes With Age-Related Macular Degeneration. *Investigative ophthalmology & visual science* 57 (14), 5843–5855.
- McManus, R.M. and Heneka, M.T. (2017) Role of neuroinflammation in neurodegeneration: new insights. *Alzheimer's research & therapy* 9 (1), 14.
- Mendoza, A.E., Young, R., Orkin, S.H. and Collins, T. (1990) Increased platelet-derived growth factor A-chain expression in human uterine smooth muscle cells during the physiologic hypertrophy of pregnancy. *Proceedings of the National Academy of Sciences of the United States of America* 87 (6), 2177–2181.
- Miller, A.-F. (2012) Superoxide dismutases: ancient enzymes and new insights. *FEBS letters* 586 (5), 585–595.
- Mittelbronn, M., Dietz, K., Schluessener, H.J. and Meyermann, R. (2001) Local distribution of microglia in the normal adult human central nervous system differs by up to one order of magnitude. *Acta neuropathologica* 101 (3), 249–255.
- Miyake, S., Mullane-Robinson, K.P., Lill, N.L., Douillard, P. and Band, H. (1999) Cbl-mediated Negative Regulation of Platelet-derived Growth Factor Receptor-dependent Cell Proliferation. *Journal of Biological Chemistry* 274 (23), 16619–16628.
- Miyata, T., Toho, T., Nonoguchi, N., Furuse, M., Kuwabara, H., Yoritsune, E., Kawabata, S., Kuroiwa, T. and Miyatake, S.-I. (2014) The roles of platelet-derived growth factors and their receptors in brain radiation necrosis. *Radiation oncology* 9, 51.

- Miyazawa, K., Bäckström, G., Leppänen, O., Persson, C., Wernstedt, C., Hellman, U., Heldin, C.H. and Ostman, A. (1998) Role of immunoglobulin-like domains 2-4 of the platelet-derived growth factor alpha-receptor in ligand-receptor complex assembly. *The Journal of biological chemistry* 273 (39), 25495–25502.
- Mo, F.M., Proia, A.D., Johnson, W.H., Cyr, D. and Lashkari, K. (2010) Interferon gamma-inducible protein-10 (IP-10) and eotaxin as biomarkers in age-related macular degeneration. *Investigative ophthalmology & visual science* 51 (8), 4226–4236.
- Mol, C.D., Lim, K.B., Sridhar, V., Zou, H., Chien, E.Y.T., Sang, B.-C., Nowakowski, J., Kassel, D.B., Cronin, C.N. and McRee, D.E. (2003) Structure of a c-kit product complex reveals the basis for kinase transactivation. *The Journal of biological chemistry* 278 (34), 31461–31464.
- Möller, T. (2010) Neuroinflammation in Huntington's disease. *Journal of neural transmission* 117 (8), 1001–1008.
- Monfar, M., Lemon, K.P., Grammer, T.C., Cheatham, L., Chung, J., Vlahos, C.J. and Blenis, J. (1995) Activation of pp70/85 S6 kinases in interleukin-2-responsive lymphoid cells is mediated by phosphatidylinositol 3-kinase and inhibited by cyclic AMP. *Molecular and cellular biology* 15 (1), 326–337.
- Mooney, R.A., Freund, G.G., Way, B.A. and Bordwell, K.L. (1992) Expression of a transmembrane phosphotyrosine phosphatase inhibits cellular response to platelet-derived growth factor and insulin-like growth factor-1. *The Journal of biological chemistry* 267 (33), 23443–23446.
- Mori, S., Heldin, C.H. and Claesson-Welsh, L. (1992) Ligand-induced polyubiquitination of the platelet-derived growth factor beta-receptor. *The Journal of biological chemistry* 267 (9), 6429–6434.
- Mori, S., Rönstrand, L., Claesson-Welsh, L. and Heldin, C.H. (1994) A tyrosine residue in the juxtamembrane segment of the platelet-derived growth factor beta-receptor is critical for ligand-mediated endocytosis. *The Journal of biological chemistry* 269 (7), 4917–4921.
- Mori, S., Rönstrand, L., Engstrom, A., Courtneidge, S.A., Claesson-welsh, L. and Heldin, C. (1993) Identification of two juxtamembrane autophosphorylation sites in the PDGF beta-receptor; involvement in the interaction with Src family tyrosine kinases. *The EMBO journal* 12 (6), 2257–2264.
- Mori, S., Tanaka, K., Omura, S. and Saito, Y. (1995) Degradation process of ligand-stimulated platelet-derived growth factor beta-receptor involves ubiquitin-proteasome proteolytic pathway. *The Journal of biological chemistry* 270 (49), 29447–29452.
- Morioka, T., Kalehua, A.N. and Streit, W.J. (1993) Characterization of microglial reaction after middle cerebral artery occlusion in rat brain. *The Journal of comparative neurology* 327 (1), 123–132.
- Moriya, S., Kazlauskas, A., Akimoto, K., Hirai, S., Mizuno, K., Takenawa, T., Fukui, Y., Watanabe, Y., Ozaki, S. and Ohno, S. (1996) Platelet-derived growth factor activates protein kinase C epsilon through redundant and independent signaling pathways involving phospholipase C gamma or phosphatidylinositol 3-kinase.

- Proceedings of the National Academy of Sciences of the United States of America* 93 (1), 151–155.
- Morrison, D.K. (2012) MAP kinase pathways. *Cold Spring Harbor Perspectives in Biology* 4 (11), 1–5.
- Morrison, D.K. and Davis, R.J. (2003) Regulation of MAP kinase signaling modules by scaffold proteins in mammals. *Annual review of cell and developmental biology* 19, 91–118.
- Mosmann, T. (1983) Rapid colorimetric assay for cellular growth and survival: application to proliferation and cytotoxicity assays. *Journal of immunological methods* 65 (1–2), 55–63.
- Mrdjen, D., Pavlovic, A., Hartmann, F.J., Schreiner, B., Utz, S.G., Leung, B.P., Lelios, I., Heppner, F.L., Kipnis, J., Merkler, D., Greter, M. and Becher, B. (2018) High-Dimensional Single-Cell Mapping of Central Nervous System Immune Cells Reveals Distinct Myeloid Subsets in Health, Aging, and Disease. *Immunity* 48 (2), 380-395.e6.
- Muda, M., Theodosiou, A., Rodrigues, N., Boschert, U., Camps, M., Gillieron, C., Davies, K., Ashworth, A. and Arkinstall, S. (1996) The dual specificity phosphatases M3/6 and MKP-3 are highly selective for inactivation of distinct mitogen-activated protein kinases. *The Journal of biological chemistry* 271 (44), 27205–27208.
- Mudhar, H.S., Pollock, R.A., Wang, C., Stiles, C.D. and Richardson, W.D. (1993) PDGF and its receptors in the developing rodent retina and optic nerve. *Development* 118 (2), 539–552.
- Muratoglu, S.C., Mikhailenko, I., Newton, C., Migliorini, M. and Strickland, D.K. (2010) Low density lipoprotein receptor-related protein 1 (LRP1) forms a signaling complex with platelet-derived growth factor receptor-beta in endosomes and regulates activation of the MAPK pathway. *The Journal of biological chemistry* 285 (19), 14308–14317.
- Nakanishi, H., Brewer, K.A. and Exton, J.H. (1993) Activation of the zeta isozyme of protein kinase C by phosphatidylinositol 3,4,5-trisphosphate. *The Journal of biological chemistry* 268 (1), 13–16.
- Nakielnny, S., Cohen, P., Wu, J. and Sturgill, T. (1992) MAP kinase activator from insulin-stimulated skeletal muscle is a protein threonine/tyrosine kinase. *The EMBO Journal* 11 (6), 2123–2129.
- Nånberg, E. and Westermark, B. (1993) Platelet-derived growth factor increases the turnover of GTP/GDP on ras in permeabilized fibroblasts. *The Journal of biological chemistry* 268 (24), 18187–18194.
- Nayak, D., Roth, T.L. and McGavern, D.B. (2014) Microglia Development and Function. *Annual Review of Immunology* 32 (1), 367–402.
- Neumann, H. and Takahashi, K. (2007) Essential role of the microglial triggering receptor expressed on myeloid cells-2 (TREM2) for central nervous tissue immune homeostasis. *Journal of Neuroimmunology* 184 (1), 92–99.
- Nimmerjahn, A., Kirchhoff, F. and Helmchen, F. (2005) Resting Microglial Cells Are

- Highly Dynamic Surveillants of Brain Parenchyma in Vivo. *Science* 308 (5726), 1314–1318.
- Nishimura, R., Li, W., Kashishian, A., Mondino, A., Zhou, M. and Cooper, J. (1993) Two Signaling Molecules Share a Phosphotyrosine-Containing Binding Site in the Platelet-Derived Growth Factor Receptor. *Molecular and cellular biology* 13 (11), 6889–6896.
- Noël, A., Jost, M., Lambert, V., Lecomte, J. and Rakic, J.-M. (2007) Anti-angiogenic therapy of exudative age-related macular degeneration: current progress and emerging concepts. *Trends in Molecular Medicine* 13 (8), 345–352.
- Norden, D.M., Muccigrosso, M.M. and Godbout, J.P. (2015) Microglial priming and enhanced reactivity to secondary insult in aging, and traumatic CNS injury, and neurodegenerative disease. *Neuropharmacology* 96, 29–41.
- O'Hagan, R.C., Tozer, R.G., Symons, M., McCormick, F. and Hassell, J.A. (1996) The activity of the Ets transcription factor PEA3 is regulated by two distinct MAPK cascades. *Oncogene* 13 (6), 1323–1333.
- Olson, J.K. and Miller, S.D. (2004) Microglia Initiate Central Nervous System Innate and Adaptive Immune Responses through Multiple TLRs. *The Journal of Immunology* 173 (6), 3916–3924.
- Olson, L.E. and Soriano, P. (2011) PDGFR $\beta$  signaling regulates mural cell plasticity and inhibits fat development. *Developmental cell* 20 (6), 815–826.
- Olson, M.F., Ashworth, A. and Hall, A. (1995) An essential role for Rho, Rac, and Cdc42 GTPases in cell cycle progression through G1. *Science* 269 (5228), 1270–1272.
- Omura, T., Heldin, C. and Arne, O. (1997) Immunoglobulin-like Domain 4-mediated Receptor-Receptor Interactions Contribute to Platelet-derived Growth Factor-induced Receptor Dimerization. *Journal of Biological Chemistry* 272 (19), 12676–12682.
- Ostendorf, T., Eitner, F. and Floege, J. (2012) The PDGF family in renal fibrosis. *Pediatric Nephrology* 27 (7), 1041–1050.
- Ostman, A. and Heldin, C.-H. (2007) PDGF receptors as targets in tumor treatment. *Advances in cancer research* 97, 247–274.
- Östman, A. and Heldin, C.-H.B.T.-A. in C.R. (2001) Involvement of platelet-derived growth factor in disease: development of specific antagonists. *Advances in Cancer Research* Academic Press. 1–38.
- Owens, D.M. and Keyse, S.M. (2007) Differential regulation of MAP kinase signalling by dual-specificity protein phosphatases. *Oncogene* 26 (22), 3203–3213.
- Panday, A., Sahoo, M.K., Osorio, D. and Batra, S. (2015) NADPH oxidases: an overview from structure to innate immunity-associated pathologies. *Cellular & Molecular Immunology* 12 (1), 5–23.
- Papadopoulos, N. and Lennartsson, J. (2018) The PDGF/PDGFR pathway as a drug target. *Molecular Aspects of Medicine* 62, 75–88.

- Parker, C.G., Hunt, J., Diener, K., McGinley, M., Soriano, B., Keesler, G.A., Bray, J., Yao, Z., Wang, X.S., Kohno, T. and Lichenstein, H.S. (1998) Identification of Stathmin as a Novel Substrate for p38 Delta. *Biochemical and Biophysical Research Communications* 249 (3), 791–796.
- Patro, I., Nagayach, A., Sinha, S. and Patro, N. in N Jana, A Basu & PN Tandon (editors), (2016) General physiology and pathophysiology of microglia during neuroinflammation, in *Inflammation: The Common Link in Brain Pathologies 1st Edn* Springer Singapore. 17–42.
- Pawson, T. and Nash, P. (2003) Assembly of cell regulatory systems through protein interaction domains. *Science* 300 (5618), 445–452.
- Pawson, T. and Scott, J.D. (1997) Signaling through scaffold, anchoring, and adaptor proteins. *Science* 278 (5346), 2075–2080.
- Pearson, G., Robinson, F., Gibson, T.B., Xu, B.E., Karandikar, M., Berman, K. and Cobb, M.H. (2001) Mitogen-activated protein (MAP) kinase pathways: Regulation and physiological functions. *Endocrine Reviews* 22 (2), 153–183.
- Pelvig, D.P., Pakkenberg, H., Stark, A.K. and Pakkenberg, B. (2008) Neocortical glial cell numbers in human brains. *Neurobiology of Aging* 29 (11), 1754–1762.
- Penfold, P.L., Madigan, M.C., Gillies, M.C. and Provis, J.M. (2001) Immunological and Aetiological Aspects of Macular Degeneration. *Progress in Retinal and Eye Research* 20 (3), 385–414.
- Pennock, S. and Kazlauskas, A. (2012) Vascular Endothelial Growth Factor A Competitively Inhibits Platelet-Derived Growth Factor (PDGF)-Dependent Activation of PDGF Receptor and Subsequent Signaling Events and Cellular Responses. *Molecular and Cellular Biology* 32 (10), 1955–1966.
- Peppel, K., Zhang, L., Orman, E.S., Hagen, P.-O., Amalfitano, A., Brian, L. and Freedman, N.J. (2005) Activation of vascular smooth muscle cells by TNF and PDGF: overlapping and complementary signal transduction mechanisms. *Cardiovascular research* 65 (3), 674–682.
- Perez-Albuerne, E.D., Schatteman, G., Sanders, L.K. and Nathans, D. (1993) Transcriptional regulatory elements downstream of the JunB gene. *Proceedings of the National Academy of Sciences of the United States of America* 90 (24), 11960–11964.
- Perry, V.H. and Holmes, C. (2014) Microglial priming in neurodegenerative disease. *Nature Reviews Neurology* 10 (4), 217–224.
- Perry, V.H., Nicoll, J.A.R. and Holmes, C. (2010) Microglia in neurodegenerative disease. *Nature Reviews Neurology* 6 (4), 193–201.
- Persengiev, S.P., Zhu, X. and Green, M.R. (2004) Nonspecific, concentration-dependent stimulation and repression of mammalian gene expression by small interfering RNAs (siRNAs). *RNA* 10 (1), 12–18.
- Persson, C., Sävenhed, C., Bourdeau, A., Tremblay, M.L., Markova, B., Böhmer, F.D., Haj, F.G., Neel, B.G., Elson, A., Heldin, C.-H., Rönstrand, L., Ostman, A. and Hellberg, C. (2004) Site-selective regulation of platelet-derived growth factor beta receptor tyrosine phosphorylation by T-cell protein tyrosine phosphatase.

- Molecular and cellular biology* 24 (5), 2190–2201.
- Peti, W. and Page, R. (2013) Molecular basis of MAP kinase regulation. *Protein Science* 22 (12), 1698–1710.
- Pimienta, G. and Pascual, J. (2007) Canonical and alternative MAPK signaling. *Cell Cycle* 6 (21), 2628–2632.
- Pinzani, M., Milani, S., Grappone, C., Weber, F.L.J., Gentilini, P. and Abboud, H.E. (1994) Expression of platelet-derived growth factor in a model of acute liver injury. *Hepatology* 19 (3), 701–707.
- Pinzani, M., Milani, S., Herbst, H., DeFranco, R., Grappone, C., Gentilini, A., Caligiuri, A., Pellegrini, G., Ngo, D. V, Romanelli, R.G. and Gentilini, P. (1996) Expression of platelet-derived growth factor and its receptors in normal human liver and during active hepatic fibrogenesis. *The American journal of pathology* 148 (3), 785–800.
- Plotnikov, A., Zehorai, E., Procaccia, S. and Seger, R. (2011) The MAPK cascades: Signaling components, nuclear roles and mechanisms of nuclear translocation. *Biochimica et Biophysica Acta - Molecular Cell Research* 1813 (9), 1619–1633.
- Pontén, A., Folestad, E.B., Pietras, K. and Eriksson, U. (2005) Platelet-derived growth factor D induces cardiac fibrosis and proliferation of vascular smooth muscle cells in heart-specific transgenic mice. *Circulation research* 97 (10), 1036–1045.
- Poon, M., Hsu, W.C., Bogdanov, V.Y. and Taubman, M.B. (1996) Secretion of monocyte chemotactic activity by cultured rat aortic smooth muscle cells in response to PDGF is due predominantly to the induction of JE/MCP-1. *The American journal of pathology* 149 (1), 307–317.
- Prinz, M. and Priller, J. (2014) Microglia and brain macrophages in the molecular age: from origin to neuropsychiatric disease. *Nature Reviews Neuroscience* 15 (5), 300–312.
- Prinz, M., Priller, J., Sisodia, S.S. and Ransohoff, R.M. (2011) Heterogeneity of CNS myeloid cells and their roles in neurodegeneration. *Nature Neuroscience* 14 (10), 1227–1235.
- Qi, M. and Elion, E.A. (2005) MAP kinase pathways. *Journal of Cell Science* 118 (16), 3569–3572.
- Qiu, R.-G., Chen, J., Kirn, D., McCormick, F. and Symons, M. (1995) An essential role for Rac in Ras transformation. *Nature* 374 (6521), 457–459.
- Qiu, R.G., Abo, A., McCormick, F. and Symons, M. (1997) Cdc42 regulates anchorage-independent growth and is necessary for Ras transformation. *Molecular and cellular biology* 17 (6), 3449–3458.
- Raica, M. and Cimpean, A.M. (2010) Platelet-Derived Growth Factor (PDGF)/PDGF Receptors (PDGFR) Axis as Target for Antitumor and Antiangiogenic Therapy. *Pharmaceuticals* 3 (3), 572–599.
- Raines, E.W. (2004) PDGF and cardiovascular disease. *Cytokine & growth factor reviews* 15 (4), 237–254.

- Raman, M., Chen, W. and Cobb, M.H. (2007) Differential regulation and properties of MAPKs. *Oncogene* 26 (22), 3100–3112.
- Ransohoff, R.M. and Cardona, A.E. (2010) The myeloid cells of the central nervous system parenchyma. *Nature* 468 (7321), 253–262.
- Ransohoff, R.M. and Perry, V.H. (2009) Microglial Physiology: Unique Stimuli, Specialized Responses. *Annual Review of Immunology* 27 (1), 119–145.
- Rathnasamy, G., Foulds, W.S., Ling, E.-A. and Kaur, C. (2019) Retinal microglia – A key player in healthy and diseased retina. *Progress in Neurobiology* 173, 18–40.
- Rauch, B.H., Weber, A., Braun, M., Zimmermann, N. and Schrör, K. (2000) PDGF-induced Akt phosphorylation does not activate NF-kappa B in human vascular smooth muscle cells and fibroblasts. *FEBS letters* 481 (1), 3–7.
- Reczek, C.R. and Chandel, N.S. (2015) ROS-dependent signal transduction. *Current opinion in cell biology* 33, 8–13.
- Reddi, A.L., Ying, G., Duan, L., Chen, G., Dimri, M., Douillard, P., Druker, B.J., Naramura, M., Band, V. and Band, H. (2007) Binding of Cbl to a phospholipase Cgamma1-docking site on platelet-derived growth factor receptor beta provides a dual mechanism of negative regulation. *The Journal of biological chemistry* 282 (40), 29336–29347.
- Reneker, L.W. and Overbeek, P.A. (1996) Lens-Specific Expression of PDGF-A Alters Lens Growth and Development. *Developmental Biology* 180 (2), 554–565.
- Réu, P., Khosravi, A., Bernard, S., Mold, J.E., Salehpour, M., Alkass, K., Perl, S., Tisdale, J., Possnert, G., Druid, H. and Frisén, J. (2017) The Lifespan and Turnover of Microglia in the Human Brain. *Cell reports* 20 (4), 779–784.
- Reynolds, C.H., Nebreda, A.R., Gibb, G.M., Utton, M.A. and Anderton, B.H. (1997) Reactivating Kinase/p38 Phosphorylates  $\tau$  Protein In Vitro. *Journal of Neurochemistry* 69 (1), 191–198.
- Rezaie, P. (2003) Microglia in the Human Nervous System during Development. *Neuroembryology and Aging* 2 (1), 18–31.
- Rezaie, P., Dean, A., Male, D. and Ulfing, N. (2004) Microglia in the Cerebral Wall of the Human Telencephalon at Second Trimester. *Cerebral Cortex* 15 (7), 938–949.
- Rezaie, P. and Male, D. (1999) Colonisation of the developing human brain and spinal cord by microglia: a review. *Microscopy research and technique* 45 (6), 359–382.
- Rezaie, P. and Male, D. (2002) Differentiation, Ramification and Distribution of Microglia within the Central Nervous System Examined. *Neuroembryology and Aging* 1 (1), 29–43.
- Riehle, K.J., Johnson, M.M., Johansson, F., Bauer, R.L., Hayes, B.J., Gilbertson, D.G., Haran, A.C., Fausto, N. and Campbell, J.S. (2014) Tissue-type plasminogen activator is not necessary for platelet-derived growth factor-c activation. *Biochimica et biophysica acta* 1842 (2), 318–325.
- Rincón, M. and Davis, R.J. (2009) Regulation of the immune response by stress-activated protein kinases. *Immunological reviews* 228 (1), 212–224.



- Risau, W. (1997) Mechanisms of angiogenesis. *Nature* 386 (6626), 671–674.
- Robbins, S.G., Mixon, R.N., Wilson, D.J., Hart, C.E., Robertson, J.E., Westra, I., Planck, S.R. and Rosenbaum, J.T. (1994) Platelet-derived growth factor ligands and receptors immunolocalized in proliferative retinal diseases. *Investigative ophthalmology & visual science* 35 (10), 3649–3663.
- Robinson, D.R., Wu, Y.-M. and Lin, S.-F. (2000) The protein tyrosine kinase family of the human genome. *Oncogene* 19 (49), 5548–5557.
- Robson, M.C., Phillips, L.G., Robson, L.E., Thomason, A. and Pierce, G.F. (1992) Platelet-derived growth factor BB for the treatment of chronic pressure ulcers. *The Lancet* 339 (8784), 23–25.
- Rodriguez-Viciano, P., Warne, P.H., Dhand, R., Vanhaesebroeck, B., Gout, I., Fry, M.J., Waterfield, M.D. and Downward, J. (1994) Phosphatidylinositol-3-OH kinase direct target of Ras. *Nature* 370 (6490), 527–532.
- Romashkova, J.A. and Makarov, S.S. (1999) NF- $\kappa$ B is a target of AKT in anti-apoptotic PDGF signalling. *Nature* 401 (6748), 86–90.
- Rönstrand, L. (2010) Signaling by the Platelet-Derived Growth Factor Receptor Family. *Handbook of Cell Signaling*, 2/e 427–434.
- Rosadini, C. V and Kagan, J.C. (2017) Early innate immune responses to bacterial LPS. *Current Opinion in Immunology* 44, 14–19.
- Rosenkranz, S., Ikuno, Y., Leong, F.L., Klinghoffer, R.A., Miyake, S., Band, H. and Kazlauskas, A. (2000) Src family kinases negatively regulate platelet-derived growth factor alpha receptor-dependent signaling and disease progression. *The Journal of biological chemistry* 275 (13), 9620–9627.
- Roskoski, R. (2012) ERK1/2 MAP kinases: Structure, function, and regulation. *Pharmacological Research* 66 (2), 105–143.
- Rosner, M., Siegel, N., Fuchs, C., Slabina, N., Dolznig, H. and Hengstschläger, M. (2010) Efficient siRNA-mediated prolonged gene silencing in human amniotic fluid stem cells. *Nature Protocols* 5 (6), 1081–1095.
- Ross, R. (1993) The pathogenesis of atherosclerosis: a perspective for the 1990s. *Nature* 362 (6423), 801–809.
- Rossomando, A.J., Payne, D.M., Weber, M.J. and Sturgill, T.W. (1989) Evidence that pp42, a major tyrosine kinase target protein, is a mitogen-activated serine/threonine protein kinase. *Proceedings of the National Academy of Sciences of the United States of America* 86 (18), 6940–6943.
- van Rossum, D. and Hanisch, U.-K. (2004) Microglia. *Metabolic brain disease* 19 (3–4), 393–411.
- Rouse, J., Cohen, P., Trigon, S., Morange, M., Alonso-Llamazares, A., Zamanillo, D., Hunt, T. and Nebreda, A.R. (1994) A novel kinase cascade triggered by stress and heat shock that stimulates MAPKAP kinase-2 and phosphorylation of the small heat shock proteins. *Cell* 78 (6), 1027–1037.
- Roy, P.K., Rashid, F., Bragg, J. and Ibdah, J.A. (2008) Role of the JNK signal

- transduction pathway in inflammatory bowel disease. *World journal of gastroenterology* 14 (2), 200–202.
- Rubartelli, A. and Lotze, M.T. (2007) Inside, outside, upside down: damage-associated molecular-pattern molecules (DAMPs) and redox. *Trends in Immunology* 28 (10), 429–436.
- Rubinfeld, H. and Seger, R. (2005) The ERK cascade: a prototype of MAPK signaling. *Molecular biotechnology* 31 (2), 151–174.
- Rutherford, C., Martin, W., Carrier, M., Anggård, E.E. and Ferns, G.A. (1997) Endogenously elicited antibodies to platelet derived growth factor-BB and platelet cytosolic protein inhibit aortic lesion development in the cholesterol-fed rabbit. *International journal of experimental pathology* 78 (1), 21–32.
- Rymo, S.F., Gerhardt, H., Wolfhagen Sand, F., Lang, R., Uv, A. and Betsholtz, C. (2011) A two-way communication between microglial cells and angiogenic sprouts regulates angiogenesis in aortic ring cultures. *PloS one* 6 (1), e15846–e15846.
- Salojin, K. and Oravecz, T. (2007) Regulation of innate immunity by MAPK dual-specificity phosphatases: knockout models reveal new tricks of old genes. *Journal of Leukocyte Biology* 81 (4), 860–869.
- Salter, M.W. and Stevens, B. (2017) Microglia emerge as central players in brain disease. *Nature Medicine* 23 (9), 1018–1027.
- Salvador, J.M., Mittelstadt, P.R., Guszczynski, T., Copeland, T.D., Yamaguchi, H., Appella, E., Jr, A.J.F. and Ashwell, J.D. (2005) Alternative p38 activation pathway mediated by T cell receptor–proximal tyrosine kinases. *Nature Immunology* 6 (4), 390–395.
- Sarbassov, D.D., Guertin, D.A., Ali, S.M. and Sabatini, D.M. (2005) Phosphorylation and regulation of Akt/PKB by the rictor-mTOR complex. *Science* 307 (5712), 1098–1101.
- Sarkar, S., Malovic, E., Sarda, D., Lawana, V., Rokad, D., Jin, H., Anantharam, V., Kanthasamy, A. and Kanthasamy, A.G. (2018) Characterization and comparative analysis of a new mouse microglial cell model for studying neuroinflammatory mechanisms during neurotoxic insults. *NeuroToxicology* 67, 129–140.
- Satoh, T., Fantl, W.J., Escobedo, J.A., Williams, L.T. and Kaziro, Y. (1993) Platelet-derived growth factor receptor mediates activation of ras through different signaling pathways in different cell types. *Molecular and cellular biology* 13 (6), 3706–3713.
- Saxena, S., Jónsson, Z.O. and Dutta, A. (2003) Small RNAs with imperfect match to endogenous mRNA repress translation. Implications for off-target activity of small inhibitory RNA in mammalian cells. *The Journal of biological chemistry* 278 (45), 44312–44319.
- Saxton, R.A. and Sabatini, D.M. (2017) mTOR Signaling in Growth, Metabolism, and Disease. *Cell* 168 (6), 960–976.
- Scacheri, P.C., Rozenblatt-Rosen, O., Caplen, N.J., Wolfsberg, T.G., Umayam, L., Lee, J.C., Hughes, C.M., Shanmugam, K.S., Bhattacharjee, A., Meyerson, M. and

- Collins, F.S. (2004) Short interfering RNAs can induce unexpected and divergent changes in the levels of untargeted proteins in mammalian cells. *Proceedings of the National Academy of Sciences of the United States of America* 101 (7), 1892–1897.
- Schaeffer, H.J. and Weber, M.J. (1999) Mitogen-Activated Protein Kinases: Specific Messages from Ubiquitous Messengers. *Molecular and Cellular Biology* 19 (4), 2435–2444.
- Schatteman, G.C., Morrison-Graham, K., van Koppen, A., Weston, J.A. and Bowen-Pope, D.F. (1992) Regulation and role of PDGF receptor alpha-subunit expression during embryogenesis. *Development* 115 (1), 123–131.
- Scheid, M.P. and Woodgett, J.R. (2001) PKB/AKT: functional insights from genetic models. *Nature reviews. Molecular cell biology* 2 (10), 760–768.
- Schermuly, R.T., Dony, E., Ghofrani, H.A., Pullamsetti, S., Savai, R., Roth, M., Sydykov, A., Lai, Y.J., Weissmann, N., Seeger, W. and Grimminger, F. (2005) Reversal of experimental pulmonary hypertension by PDGF inhibition. *The Journal of clinical investigation* 115 (10), 2811–2821.
- Schlessinger, J. (1993) How receptor tyrosine kinases activate Ras. *Trends in biochemical sciences* 18 (8), 273–275.
- Schulz, C., Gomez Perdiguero, E., Chorro, L., Szabo-Rogers, H., Cagnard, N., Kierdorf, K., Prinz, M., Wu, B., Jacobsen, S.E.W., Pollard, J.W., Frampton, J., Liu, K.J. and Geissmann, F. (2012) A lineage of myeloid cells independent of Myb and hematopoietic stem cells. *Science* 336 (6077), 86–90.
- Scott, A.W. and Bressler, S.B. (2013) Long-term follow-up of vascular endothelial growth factor inhibitor therapy for neovascular age-related macular degeneration. *Current opinion in ophthalmology* 24 (3), 190–196.
- Seifert, R.A., Hart, C.E., Phillips, P.E., Forstrom, J.W., Ross, R., Murray, M.J. and Bowen-Pope, D.F. (1989) Two different subunits associate to create isoform-specific platelet-derived growth factor receptors. *The Journal of biological chemistry* 264 (15), 8771–8778.
- Semizarov, D., Kroeger, P. and Fesik, S. (2004) siRNA-mediated gene silencing: a global genome view. *Nucleic acids research* 32 (13), 3836–3845.
- Semple, B.D., Kossmann, T. and Morganti-Kossmann, M.C. (2010) Role of chemokines in CNS health and pathology: a focus on the CCL2/CCR2 and CXCL8/CXCR2 networks. *Journal of cerebral blood flow and metabolism : official journal of the International Society of Cerebral Blood Flow and Metabolism* 30 (3), 459–473.
- Shah, G.D., Loizos, N., Youssoufian, H., Schwartz, J.D. and Rowinsky, E.K. (2010) Rationale for the development of IMC-3G3, a fully human immunoglobulin G subclass 1 monoclonal antibody targeting the platelet-derived growth factor receptor alpha. *Cancer* 116 (4 Suppl), 1018–1026.
- Shaul, Y.D. and Seger, R. (2007) The MEK/ERK cascade: From signaling specificity to diverse functions. *Biochimica et Biophysica Acta - Molecular Cell Research* 1773 (8), 1213–1226.

- Shim, A.H., Liu, H., Focia, P.J., Chen, X., Lin, P.C. and He, X. (2010) Structures of a platelet-derived growth factor/propeptide complex and a platelet-derived growth factor/receptor complex. *Proceedings of the National Academy of Sciences* 107 (25), 11307–11312.
- Sierra, A., Encinas, J.M., Deudero, J.J.P., Chancey, J.H., Enikolopov, G., Overstreet-Wadiche, L.S., Tsirka, S.E. and Maletic-Savatic, M. (2010) Microglia shape adult hippocampal neurogenesis through apoptosis-coupled phagocytosis. *Cell stem cell* 7 (4), 483–495.
- Smith, A.M. and Dragunow, M. (2014) The human side of microglia. *Trends in Neurosciences* 37 (3), 125–135.
- Smits, A., Funa, K., Vassbotn, F.S., Beausang-Linder, M., af Ekenstam, F., Heldin, C.H., Westermark, B. and Nistér, M. (1992) Expression of platelet-derived growth factor and its receptors in proliferative disorders of fibroblastic origin. *The American journal of pathology* 140 (3), 639–648.
- Smits, A., Hermansson, M., Nistér, M., Karnushina, I., Heldin, C.H., Westermark, B. and Funa, K. (1989) Rat brain capillary endothelial cells express functional PDGF B-type receptors. *Growth factors* 2 (1), 1–8.
- Songyang, Z., Lu, K.P., Kwon, Y.T., Tsai, L.H., Filhol, O., Cochet, C., Brickey, D.A., Soderling, T.R., Bartleson, C., Graves, D.J., DeMaggio, A.J., Hoekstra, M.F., Blenis, J., Hunter, T. and Cantley, L.C. (1996) A structural basis for substrate specificities of protein Ser/Thr kinases: primary sequence preference of casein kinases I and II, NIMA, phosphorylase kinase, calmodulin-dependent kinase II, CDK5, and Erk1. *Molecular and cellular biology* 16 (11), 6486–6493.
- Sorce, S., Nuvolone, M., Keller, A., Falsig, J., Varol, A., Schwarz, P., Bieri, M., Budka, H. and Aguzzi, A. (2014) The role of the NADPH oxidase NOX2 in prion pathogenesis. *PLoS pathogens* 10 (12), e1004531.
- Soriano, P. (1994) Abnormal kidney development and hematological disorders in PDGF beta-receptor mutant mice. *Genes & development* 8 (16), 1888–1896.
- Soriano, P. (1997) The PDGF alpha receptor is required for neural crest cell development and for normal patterning of the somites. *Development* 124 (14), 2691–2700.
- Sorkin, A., Eriksson, A., Heldin, C.H., Westermark, B. and Claesson-Welsh, L. (1993) Pool of ligand-bound platelet-derived growth factor beta-receptors remain activated and tyrosine phosphorylated after internalization. *Journal of cellular physiology* 156 (2), 373–382.
- Sorkin, A., Westermark, B., Heldin, C.H. and Claesson-Welsh, L. (1991) Effect of receptor kinase inactivation on the rate of internalization and degradation of PDGF and the PDGF beta-receptor. *The Journal of cell biology* 112 (3), 469–478.
- Spadoni, T., Svegliati Baroni, S., Amico, D., Albani, L., Moroncini, G., Avvedimento, E. V and Gabrielli, A. (2015) A Reactive Oxygen Species-Mediated Loop Maintains Increased Expression of NADPH Oxidases 2 and 4 in Skin Fibroblasts From Patients With Systemic Sclerosis. *Arthritis & Rheumatology* 67 (6), 1611–1622.

- Spaide, R.F. (2006) Rationale for Combination Therapies for Choroidal Neovascularization. *American Journal of Ophthalmology* 141 (1), 149–156.
- Spittau, B., Wullkopf, L., Zhou, X., Rilka, J., Pfeifer, D. and Krieglstein, K. (2013) Endogenous transforming growth factor-beta promotes quiescence of primary microglia in vitro. *Glia* 61 (2), 287–300.
- Spritz, R.A., Strunk, K.M., Lee, S.T., Lu-Kuo, J.M., Ward, D.C., Le Paslier, D., Altherr, M.R., Dorman, T.E. and Moir, D.T. (1994) A YAC contig spanning a cluster of human type III receptor protein tyrosine kinase genes (PDGFRA-KIT-KDR) in chromosome segment 4q12. *Genomics* 22 (2), 431–436.
- Stambolic, V., Suzuki, A., de la Pompa, J.L., Brothers, G.M., Mirtsos, C., Sasaki, T., Ruland, J., Penninger, J.M., Siderovski, D.P. and Mak, T.W. (1998) Negative regulation of PKB/Akt-dependent cell survival by the tumor suppressor PTEN. *Cell* 95 (1), 29–39.
- Stansley, B., Post, J. and Hensley, K. (2012) A comparative review of cell culture systems for the study of microglial biology in Alzheimer's disease. *Journal of Neuroinflammation* 9 (1), 115.
- Steck, P.A., Pershouse, M.A., Jasser, S.A., Yung, W.K.A., Lin, H., Ligon, A.H., Langford, L.A., Baumgard, M.L., Hattier, T., Davis, T., Frye, C., Hu, R., Swedlund, B., Teng, D.H.R. and Tavtigian, S. V (1997) Identification of a candidate tumour suppressor gene, MMAC1, at chromosome 10q23.3 that is mutated in multiple advanced cancers. *Nature Genetics* 15 (4), 356–362.
- Stein, B., Yang, M.X., Young, D.B., Janknecht, R., Hunter, T., Murray, B.W. and Barbosa, M.S. (1997) p38-2, a Novel Mitogen-activated Protein Kinase with Distinct Properties. *The Journal of biological chemistry* 272 (31), 19509–19517.
- Stephens, L., Anderson, K., Stokoe, D., Erdjument-Bromage, H., Painter, G.F., Holmes, A.B., Gaffney, P.R., Reese, C.B., McCormick, F., Tempst, P., Coadwell, J. and Hawkins, P.T. (1998) Protein kinase B kinases that mediate phosphatidylinositol 3,4,5-trisphosphate-dependent activation of protein kinase B. *Science (New York, N.Y.)* 279 (5351), 710–714.
- Stokoe, D., Stephens, L.R., Copeland, T., Gaffney, P.R.J., Reese, C.B., Painter, G.F., Holmes, A.B., McCormick, F. and Hawkins, P.T. (1997) Dual Role of Phosphatidylinositol-3,4,5-trisphosphate in the Activation of Protein Kinase B. *Science* 277 (5325), 567–570.
- Stout, R.D. (2010) Editorial: macrophage functional phenotypes: no alternatives in dermal wound healing? *Journal of leukocyte biology* 19–21.
- Streit, W.J., Mrak, R.E. and Griffin, W.S.T. (2004) Microglia and neuroinflammation: a pathological perspective. *Journal of neuroinflammation* 1 (1), 14.
- Streit, W.J., Xue, Q.-S., Tischer, J. and Bechmann, I. (2014) Microglial pathology. *Acta Neuropathologica Communications* 2 (1), 142.
- Strittmatter, K., Pomeroy, H. and Marneros, A.G. (2016) Targeting Platelet-Derived Growth Factor Receptor  $\beta^+$  Scaffold Formation Inhibits Choroidal Neovascularization. *The American Journal of Pathology* 186 (7), 1890–1899.
- Su, Y., Han, J., Xu, S., Cobb, M. and Skolnik, E.Y. (1997) NIK is a new Ste20-related

- kinase that binds NCK and MEKK1 and activates the SAPK/JNK cascade via a conserved regulatory domain. *The EMBO journal* 16 (6), 1279–1290.
- Sugama, S., Takenouchi, T., Cho, B.P., Joh, T.H., Hashimoto, M. and Kitani, H. (2009) Possible roles of microglial cells for neurotoxicity in clinical neurodegenerative diseases and experimental animal models. *Inflammation & allergy drug targets* 8 (4), 277–284.
- Suh, Y.-A., Arnold, R.S., Lassegue, B., Shi, J., Xu, X., Sorescu, D., Chung, A.B., Griendling, K.K. and Lambeth, J.D. (1999) Cell transformation by the superoxide-generating oxidase Mox1. *Nature* 401 (6748), 79–82.
- Sun, H., Charles, C.H., Lau, L.F. and Tonks, N.K. (1993) MKP-1 (3CH134), an immediate early gene product, is a dual specificity phosphatase that dephosphorylates MAP kinase in vivo. *Cell* 75 (3), 487–493.
- Sun, Q.-A., Runge, M.S. and Madamanchi, N.R. (2016) Oxidative stress, NADPH oxidases, and arteries. *Hamostaseologie* 36 (2), 77–88.
- Sundaresan, M., Yu, Z.X., Ferrans, V.J., Irani, K. and Finkel, T. (1995) Requirement for generation of H<sub>2</sub>O<sub>2</sub> for platelet-derived growth factor signal transduction. *Science (New York, N.Y.)* 270 (5234), 296–299.
- Swan, D.C., McBride, O.W., Robbins, K.C., Keithley, D.A., Reddy, E.P. and Aaronson, S.A. (1982) Chromosomal mapping of the simian sarcoma virus onc gene analogue in human cells. *Proceedings of the National Academy of Sciences of the United States of America* 79 (15), 4691–4695.
- Takahashi, Y., Morales, F., Kreimann, E. and Georgescu, M.-M. (2006) PTEN tumor suppressor associates with NHERF proteins to attenuate PDGF receptor signaling. *The EMBO journal* 25, 910–920.
- Takahashi, Y., Yu, Z., Sakai, M. and Tomita, H. (2016) Linking Activation of Microglia and Peripheral Monocytic Cells to the Pathophysiology of Psychiatric Disorders. *Frontiers in cellular neuroscience* 10, 144.
- Takeuchi, O. and Akira, S. (2010) Pattern recognition receptors and inflammation. *Cell* 140 (6), 805–820.
- Tallquist, M. and Kazlauskas, A. (2004) PDGF signaling in cells and mice. *Cytokine & growth factor reviews* 15 (4), 205–213.
- Tang, W.W., Ulich, T.R., Lacey, D.L., Hill, D.C., Qi, M., Kaufman, S.A., Van, G.Y., Tarpley, J.E. and Yee, J.S. (1996) Platelet-derived growth factor-BB induces renal tubulointerstitial myofibroblast formation and tubulointerstitial fibrosis. *The American journal of pathology* 148 (4), 1169–1180.
- Tanti, J.-F. and Jager, J. (2009) Cellular mechanisms of insulin resistance: role of stress-regulated serine kinases and insulin receptor substrates (IRS) serine phosphorylation. *Current Opinion in Pharmacology* 9 (6), 753–762.
- Tay, T.L., Mai, D., Dautzenberg, J., Fernández-Klett, F., Lin, G., Sagar, Datta, M., Drougard, A., Stempf, T., Ardura-Fabregat, A., Staszewski, O., Margineanu, A., Sporbert, A., Steinmetz, L.M., Pospisilik, J.A., Jung, S., Priller, J., Grün, D., Ronneberger, O. and Prinz, M. (2017) A new fate mapping system reveals context-dependent random or clonal expansion of microglia. *Nature*

- Neuroscience* 20 (6), 793–803.
- Theisen, C.S., Wahl 3rd, J.K., Johnson, K.R. and Wheelock, M.J. (2007) NHERF links the N-cadherin/catenin complex to the platelet-derived growth factor receptor to modulate the actin cytoskeleton and regulate cell motility. *Molecular biology of the cell* 18 (4), 1220–1232.
- Thomas, G.M. and Huganir, R.L. (2004) MAPK cascade signalling and synaptic plasticity. *Nature Reviews Neuroscience* 5 (3), 173–183.
- Thored, P., Heldmann, U., Gomes-Leal, W., Gisler, R., Darsalia, V., Taneera, J., Nygren, J.M., Jacobsen, S.-E.W., Ekdahl, C.T., Kokaia, Z. and Lindvall, O. (2009) Long-term accumulation of microglia with proneurogenic phenotype concomitant with persistent neurogenesis in adult subventricular zone after stroke. *Glia* 57 (8), 835–849.
- Timmerman, R., Burm, S.M. and Bajramovic, J.J. (2018) An Overview of in vitro Methods to Study Microglia. *Frontiers in cellular neuroscience* 12, 242.
- Toker, A., Meyer, M., Reddy, K.K., Falck, J.R., Aneja, R., Aneja, S., Parra, A., Burns, D.J., Ballas, L.M. and Cantley, L.C. (1994) Activation of protein kinase C family members by the novel polyphosphoinositides PtdIns-3,4-P2 and PtdIns-3,4,5-P3. *The Journal of biological chemistry* 269 (51), 32358–32367.
- Tsutsumi-Miyahara, C., Sonoda, K.-H., Egashira, K., Ishibashi, M., Qiao, H., Oshima, T., Murata, T., Miyazaki, M., Charo, I.F., Hamano, S. and Ishibashi, T. (2004) The relative contributions of each subset of ocular infiltrated cells in experimental choroidal neovascularisation. *The British journal of ophthalmology* 88 (9), 1217–1222.
- Turjanski, A.G., Vaqué, J.P. and Gutkind, J.S. (2007) MAP kinases and the control of nuclear events. *Oncogene* 26 (22), 3240–3253.
- Tuuminen, R., Nykänen, A., Keränen, M.A., Krebs, R., Alitalo, K., Koskinen, P.K. and Lemström, K.B. (2006) The Effect of Platelet-Derived Growth Factor Ligands in Rat Cardiac Allograft Vasculopathy and Fibrosis. *Transplantation Proceedings* 38 (10), 3271–3273.
- Ucuzian, A.A., Gassman, A.A., East, A.T. and Greisler, H.P. (2010) Molecular mediators of angiogenesis. *Journal of burn care & research : official publication of the American Burn Association* 31 (1), 158–175.
- Uutela, M., Laurén, J., Bergsten, E., Li, X., Horelli-Kuitunen, N., Eriksson, U. and Alitalo, K. (2001) Chromosomal location, exon structure, and vascular expression patterns of the human PDGFC and PDGFD genes. *Circulation* 103 (18), 2242–2247.
- Vajrabhaya, L. and Korsuwannawong, S. (2018) Cytotoxicity evaluation of a Thai herb using tetrazolium (MTT) and sulforhodamine B (SRB) assays. *Journal of Analytical Science and Technology* 9 (1), 15.
- Vallon, M., Chang, J., Zhang, H. and Kuo, C.J. (2014) Developmental and pathological angiogenesis in the central nervous system. *Cellular and molecular life sciences : CMLS* 71 (18), 3489–3506.
- Vanhaesebroeck, B. and Alessi, D.R. (2000) The PI3K-PDK1 connection: more than

- just a road to PKB. *The Biochemical journal* 346 (3), 561–576.
- Vanhaesebroeck, Bart, Leever, S.J., Panayotou, G. and Waterfield, M.D. (1997) Phosphoinositide 3-kinases: A conserved family of signal transducers. *Trends in Biochemical Sciences* 22 (7), 267–272.
- Vanhaesebroeck, B., Stephens, L. and Hawkins, P. (2012) PI3K signalling: The path to discovery and understanding. *Nature Reviews Molecular Cell Biology* 13 (3), 195–203.
- Vanhaesebroeck, B, Welham, M.J., Kotani, K., Stein, R., Warne, P.H., Zvelebil, M.J., Higashi, K., Volinia, S., Downward, J. and Waterfield, M.D. (1997) P110delta, a novel phosphoinositide 3-kinase in leukocytes. *Proceedings of the National Academy of Sciences of the United States of America* 94 (9), 4330–4335.
- Varnum, M.M. and Ikezu, T. (2012) The Classification of Microglial Activation Phenotypes on Neurodegeneration and Regeneration in Alzheimer's Disease Brain. *Archivum Immunologiae et Therapiae Experimentalis* 60 (4), 251–266.
- Vasek, M.J., Garber, C., Dorsey, D., Durrant, D.M., Bollman, B., Soung, A., Yu, J., Perez-Torres, C., Frouin, A., Wilton, D.K., Funk, K., DeMasters, B.K., Jiang, X., Bowen, J.R., Mennerick, S., Robinson, J.K., Garbow, J.R., Tyler, K.L., Suthar, M.S., Schmidt, R.E., Stevens, B. and Klein, R.S. (2016) A complement–microglial axis drives synapse loss during virus-induced memory impairment. *Nature* 534 (7608), 538–543.
- Vassbotnlon, F.S., Havnenpii, O.K., Heldinl, C. and Holmseno, H. (1994) Negative feedback regulation of human platelets via autocrine activation of the platelet-derived growth factor alpha-receptor. *The Journal of biological chemistry* 269 (19), 13874–13879.
- Velagapudi, R., El-Bakoush, A. and Olajide, O.A. (2018) Activation of Nrf2 Pathway Contributes to Neuroprotection by the Dietary Flavonoid Tiliroside. *Molecular neurobiology* 55 (10), 8103–8123.
- Verney, C., Monier, A., Fallet-Bianco, C. and Gressens, P. (2010) Early microglial colonization of the human forebrain and possible involvement in periventricular white-matter injury of preterm infants. *Journal of anatomy* 217 (4), 436–448.
- Vigil, D., Cherfils, J., Rossman, K.L. and Der, C.J. (2010) Ras superfamily GEFs and GAPs: validated and tractable targets for cancer therapy? *Nature reviews. Cancer* 10 (12), 842–857.
- Vivanco, I. and Sawyers, C.L. (2002) The phosphatidylinositol 3-kinase-AKT pathway in humancancer. *Nature Reviews Cancer* 2 (7), 489–501.
- Wagner, E.F. and Nebreda, Á.R. (2009) Signal integration by JNK and p38 MAPK pathways in cancer development. *Nature Reviews Cancer* 9 (8), 537–549.
- Waisman, A., Ginhoux, F., Greter, M. and Bruttger, J. (2015) Homeostasis of Microglia in the Adult Brain: Review of Novel Microglia Depletion Systems. *Trends in immunology* 36 (10), 625–636.
- Walter, M., Lucet, I.S., Patel, O., Broughton, S.E., Bamert, R., Williams, N.K., Fantino, E., Wilks, A.F. and Rossjohn, J. (2007) The 2.7 Å Crystal Structure of the Autoinhibited Human c-Fms Kinase Domain. *Journal of Molecular Biology* 367 (3),



839–847.

- Wang, H.Z., Chang, C.H., Lin, C.P. and Tsai, M.C. (1996) Using MTT viability assay to test the cytotoxicity of antibiotics and steroid to cultured porcine corneal endothelial cells. *Journal of ocular pharmacology and therapeutics: the official journal of the Association for Ocular Pharmacology and Therapeutics* 12 (1), 35–43.
- Wang, T., Pei, Z., Zhang, W., Liu, B., Langenbach, R., Lee, C., Wilson, B., Reece, J.M., Miller, D.S. and Hong, J.-S. (2005) MPP<sup>+</sup>-induced COX-2 activation and subsequent dopaminergic neurodegeneration. *The FASEB Journal* 19 (9), 1134–1136.
- Wang, X., Destrument, A. and Tournier, C. (2007) Physiological roles of MKK4 and MKK7: Insights from animal models. *Biochimica et Biophysica Acta - Molecular Cell Research* 1773 (8), 1349–1357.
- Wang, Y., Pennock, S.D., Chen, X., Kazlauskas, A. and Wang, Z. (2004) Platelet-derived growth factor receptor-mediated signal transduction from endosomes. *The Journal of biological chemistry* 279 (9), 8038–8046.
- Wang, Y., Szretter, K.J., Vermi, W., Gilfillan, S., Rossini, C., Cella, M., Barrow, A.D., Diamond, M.S. and Colonna, M. (2012) IL-34 is a tissue-restricted ligand of CSF1R required for the development of Langerhans cells and microglia. *Nature Immunology* 13 (8), 753–760.
- Waskiewicz, A.J., Flynn, A., Proud, C.G. and Cooper, J.A. (1997) Mitogen-activated protein kinases activate the serine/threonine kinases Mnk1 and Mnk2. *The EMBO journal* 16 (8), 1909–1920.
- Way, B.A. and Mooney, R.A. (1993) Activation of phosphatidylinositol-3-kinase by platelet-derived growth factor and insulin-like growth factor-1 is inhibited by a transmembrane phosphotyrosine phosphatase. *The Journal of biological chemistry* 268 (35), 26409–26415.
- Webster, N.L. and Crowe, S.M. (2006) Matrix metalloproteinases, their production by monocytes and macrophages and their potential role in HIV-related diseases. *Journal of leukocyte biology* 80 (5), 1052–1066.
- Wei, Z. and Liu, H.T. (2002) MAPK signal pathways in the regulation of cell proliferation in mammalian cells. *Cell Research* 12 (1), 9–18.
- Wellbrock, C., Karasarides, M. and Marais, R. (2004) The RAF proteins take centre stage. *Nature Reviews Molecular Cell Biology* 5 (11), 875–885.
- Weston, C.R. and Davis, R.J. (2002) The JNK signal transduction pathway. *Current Opinion in Genetics & Development* 12 (1), 14–21.
- Weston, C.R. and Davis, R.J. (2007) The JNK signal transduction pathway. *Current Opinion in Cell Biology* 19 (2), 142–149.
- Whitehead, K.A., Langer, R. and Anderson, D.G. (2009) Knocking down barriers: advances in siRNA delivery. *Nature Reviews Drug Discovery* 8 (2), 129–138.
- Whitmarsh, A.J. (2007) Regulation of gene transcription by mitogen-activated protein kinase signaling pathways. 1773, 1285–1298.

- Whitmarsh, A.J. (2006) The JIP family of MAPK scaffold proteins. *Biochemical Society Transactions* 34 (5), 828–832.
- Whitmarsh, A.J. and Davis, R.J. (2007) Role of mitogen-activated protein kinase kinase 4 in cancer. 3172–3184.
- Widmann, C., Gibson, S., Jarpe, M.B. and Johnson, G.L. (1999) Mitogen-activated protein kinase: Conservation of a three-kinase module from yeast to human. *Physiological Reviews* 79 (1), 143–180.
- Wiseman, P.W., Höddelius, P., Petersen, N.O. and Magnusson, K.-E. (1997) Aggregation of PDGF- $\beta$  receptors in human skin fibroblasts: characterization by image correlation spectroscopy (ICS). *FEBS Letters* 401 (1), 43–48.
- Wu, E., Palmer, N., Tian, Z., Moseman, A.P., Galdzicki, M., Wang, X., Berger, B., Zhang, H. and Kohane, I.S. (2008) Comprehensive dissection of PDGF-PDGFR signaling pathways in PDGFR genetically defined cells. *PloS one* 3 (11), e3794–e3794.
- Wu, X., Senechal, K., Neshat, M.S., Whang, Y.E. and Sawyers, C.L. (1998) The PTEN/MMAC1 tumor suppressor phosphatase functions as a negative regulator of the phosphoinositide 3-kinase/Akt pathway. *Proceedings of the National Academy of Sciences of the United States of America* 95 (26), 15587–15591.
- Xu, H., Chen, M. and Forrester, J. V (2009) Para-inflammation in the aging retina. *Progress in Retinal and Eye Research* 28 (5), 348–368.
- Yang, S., Zhao, J. and Sun, X. (2016) Resistance to anti-VEGF therapy in neovascular age-related macular degeneration: a comprehensive review. *Drug design, development and therapy* 10, 1857–1867.
- Yang, Y., Yuzawa, S. and Schlessinger, J. (2008) Contacts between membrane proximal regions of the PDGF receptor ectodomain are required for receptor activation but not for receptor dimerization. 105 (22), 7681–7686.
- Yao, H., Peng, F., Dhillon, N., Callen, S., Bokhari, S., Stehno-Bittel, L., Ahmad, S.O., Wang, J.Q. and Buch, S. (2009) Involvement of TRPC channels in CCL2-mediated neuroprotection against tat toxicity. *The Journal of neuroscience : the official journal of the Society for Neuroscience* 29 (6), 1657–1669.
- Yarden, Y., Escobedo, J.A., Kuang, W.J., Yang-Feng, T.L., Daniel, T.O., Tremble, P.M., Chen, E.Y., Ando, M.E., Harkins, R.N. and Francke, U. (1986) Structure of the receptor for platelet-derived growth factor helps define a family of closely related growth factor receptors. *Nature* 323 (6085), 226–232.
- Yi, E.S., Lee, H., Yin, S., Piguet, P., Sarosi, I., Kaufmann, S., Tarpley, J., Wang, N.S. and Ulich, T.R. (1996) Platelet-derived growth factor causes pulmonary cell proliferation and collagen deposition in vivo. *The American journal of pathology* 149 (2), 539–548.
- Yokote, K., Margolis, B., Heldin, C. and Claesson-welsh, L. (1996) Grb7 is a downstream signaling component of platelet-derived growth factor alpha- and beta-receptors. *The Journal of biological chemistry* 271 (48), 30942–30949.
- Yoon, S. and Seger, R. (2006) The extracellular signal-regulated kinase: Multiple substrates regulate diverse cellular functions. *Growth Factors* 24 (1), 21–44.

- Young, P., McDonnell, P., Dunnington, D., Hand, A., Laydon, J. and Lee, J. (1993) Pyridinyl imidazoles inhibit IL-1 and TNF production at the protein level. *Agents and actions* 39, C67–C69.
- Yu, J.C., Heidarani, M.A., Pierce, J.H., Gutkind, J.S., Lombardi, D., Ruggiero, M. and Aaronson, S.A. (1991) Tyrosine mutations within the alpha platelet-derived growth factor receptor kinase insert domain abrogate receptor-associated phosphatidylinositol-3 kinase activity without affecting mitogenic or chemotactic signal transduction. *Molecular and cellular biology* 11 (7), 3780–3785.
- Zarubin, T. and Han, J. (2005) Activation and signaling of the p38 MAP kinase pathway. *Cell Research* 15 (1), 11–18.
- Zeng, Y., Yi, R. and Cullen, B.R. (2003) MicroRNAs and small interfering RNAs can inhibit mRNA expression by similar mechanisms. *Proceedings of the National Academy of Sciences of the United States of America* 100 (17), 9779–9784.
- Zhan, Y., Paolicelli, R.C., Sforzini, F., Weinhard, L., Bolasco, G., Pagani, F., Vyssotski, A.L., Bifone, A., Gozzi, A., Ragozzino, D. and Gross, C.T. (2014) Deficient neuron-microglia signaling results in impaired functional brain connectivity and social behavior. *Nature Neuroscience* 17 (3), 400–406.
- Zhang, F., Hao, F., An, D., Zeng, L., Wang, Y., Xu, X. and Cui, M.-Z. (2015) The matricellular protein Cyr61 is a key mediator of platelet-derived growth factor-induced cell migration. *The Journal of biological chemistry* 290 (13), 8232–8242.
- Zhang, K. and Kaufman, R.J. (2008) From endoplasmic-reticulum stress to the inflammatory response. *Nature* 454 (7203), 455–462.
- Zhang, Y. and Dong, C. (2007) Regulatory mechanisms of mitogen-activated kinase signaling. *Cellular and Molecular Life Sciences* 64 (21), 2771–2789.
- Zhao, L., Zabel, M.K., Wang, X., Ma, W., Shah, P., Fariss, R.N., Qian, H., Parkhurst, C.N., Gan, W.-B. and Wong, W.T. (2015) Microglial phagocytosis of living photoreceptors contributes to inherited retinal degeneration. *EMBO Molecular Medicine* 7 (9), 1179–1197.
- Zhou, S., Shoelson, S.E., Chaudhuri, M., Gish, G., Pawson, T., Haser, W.G., King, F., Roberts, T., Ratnofsky, S., Lechleider, R.J., Neel, B.G., Birge, R.B., Fajardo, J.E., Chou, M.M., Hanafusa, H., Schaffhausen, B. and Cantley, L.C. (1993) SH2 domains recognize specific phosphopeptide sequences. *Cell* 72 (5), 767–778.
- Zhuo, Y., Hoyle, G.W., Zhang, J., Morris, G. and Lasky, J.A. (2003) A novel murine PDGF-D splicing variant results in significant differences in peptide expression and function. *Biochemical and Biophysical Research Communications* 308 (1), 126–132.

## APPENDIX

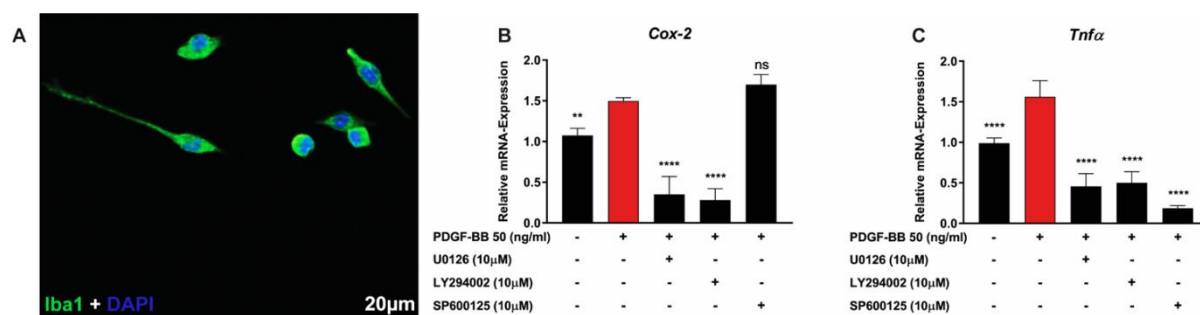
**Appendix figure 1 Primary microglial cells.**

(A) Immunostaining for Iba1 protein (Green), nuclei stained with DAPI (blue). (B and C) Quantitative PCR data of gene expression levels of *Cox-2* and *Tnfa* in PDGF-BB treated cells pre-treated with inhibitors for MEK1/2 inhibitor - U0126, PI3K - LY294002, and JNK - SP600125. Data are presented as mean  $\pm$  SD of two independent experiments measured in duplicates (N=4).  $**p \leq 0.01$ ,  $****p \leq 0.0001$  compared to PDGF-BB treated group (red bar). One-way AVOVA with Sidak's multiple comparison test.

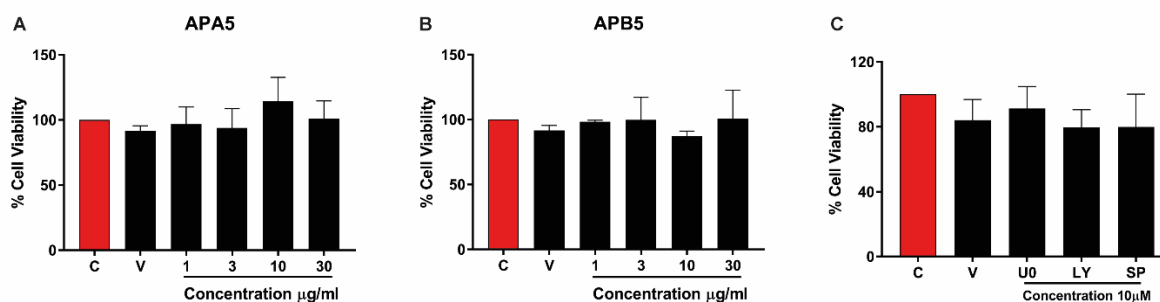
**Appendix figure 2 MTT cell viability assay in BV-2 microglial cells.**

Percentage cell viability of BV-2 microglial cells following; (A and B) 48 hours treatment with increasing concentrations of PDGFR- $\alpha$  and - $\beta$  blocking antibodies, APA5 and APB5 respectively. Data are presented as mean  $\pm$  SD of three independent experiments measured in triplicates (N=9). C - control: untreated cells, V - vehicle: DPBS (C) 4 hours treatment with kinase inhibitors. Data are presented as mean  $\pm$  SD of two to three independent experiments measured in triplicates (N=6-9). C - control: untreated cells, V - vehicle: 0.03% DMSO, U0 - U0126 (MEK1/2 inhibitor), LY - LY294002 (PI3K inhibitor) and SP - SP600125 (JNK inhibitor).

No significant differences were seen between the treatment and control group (red bar). One-way AVOVA with Dunnett's multiple comparison test.

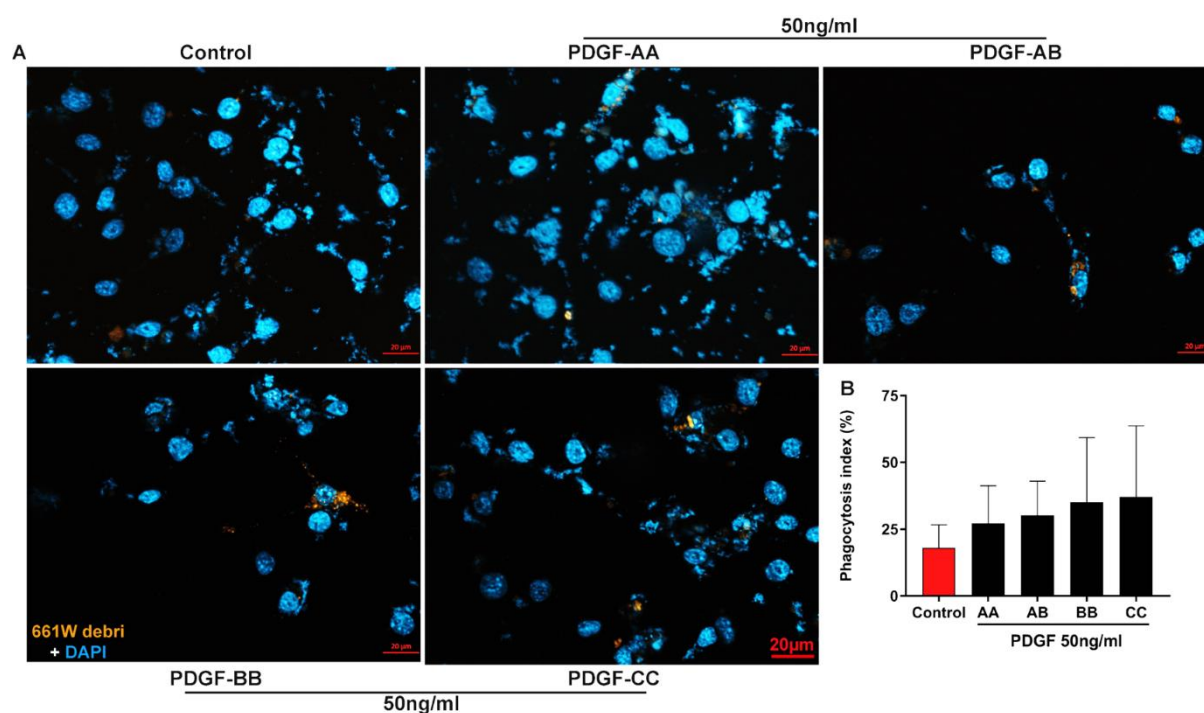

### Appendix figure 3 Effect of PDGF on BV-2 microglia phagocytic capacity.

**(A)** Representative micrograph of CM-Dil-stained apoptotic 661W photoreceptor debris phagocytosed by control and PDGF-treated BV-2 microglial cells. 661W debris (Orange), microglial cell nuclei stained with DAPI (blue). **(B)** Quantification from two experiments in duplicates (N=4). The ratio of phagocytosed 661W photoreceptor debris (background-corrected red signal) relative to the total microglial cell number (background corrected DAPI signal) was determined using Image J software and values expressed as percentages. No significant differences were seen between treatment and control group, one-way ANOVA with Dunnett's multiple comparison test. Control - 0.1% BSA in DPBS.

## ACKNOWLEDGEMENT

Foremost, to the ancient one of my soul, I thank thee for the gift of life to see the dawn of each new day.

My sincere appreciation goes to my supervisor, Prof. Dr. Thomas Langmann, thank you for affording me the opportunity of being part of the group; I do not take any of that for granted. To past and present members of the group, thank you for having me.

To Dr. Marion Rosowski, thank you for the academic support thus far, and most importantly, for facilitating that initial meeting with Thomas, I am grateful.

This feat would not have been possible without the financial support from Bayer Science and Education Foundation and the German Academic Exchange Service (DAAD), I am grateful.

To Isha Akhtar-Schäfer, Khalid Rashid and Amir Khan, thank you for all the moral support, you guys made these past four years worth the while.

To my parents, thank you for the immense guidance and support and for bringing me this far, I would always be grateful. To my siblings, you have all being a pillar of support for me; I love you all.

To Vincent, thank you for 'everything' particularly the past one year.

Prof. Oluwatoyin Odeku, thank you for all you do, for being there from inception all through to the writing phase. For the academic, moral and emotional support when I was at my lowest, thank you once again.

## Erklärung

Ich versichere, dass ich die von mir vorgelegte Dissertation selbstständig angefertigt, die benutzten Quellen und Hilfsmittel vollständig angegeben und die Stellen der Arbeit -einschließlich Tabellen, Karten und Abbildungen -, die anderen Werken im Wortlaut oder dem Sinn nach entnommen sind, in jedem Einzelfall als Entlehnung kenntlich gemacht habe; dass diese Dissertation noch keiner anderen Fakultät oder Universität zur Prüfung vorgelegen hat; dass sie - abgesehen von unten angegebenen Teilpublikationen - noch nicht veröffentlicht worden ist sowie, dass ich eine solche Veröffentlichung vor Abschluss des Promotionsverfahrens nicht vornehmen werde. Die Bestimmungen dieser Promotionsordnung sind mir bekannt. Die von mir vorgelegte Dissertation ist von Herrn Prof. Dr. Thomas Langman betreut worden.

## Übersicht der Publikationen

Rashid, K., Verhoyen, M., **Taiwo, M.** and Langmann, T. (2020) Translocator protein (18 kDa) (TSPO) ligands activate Nrf2 signaling and attenuate inflammatory responses and oxidative stress in human retinal pigment epithelial cells. *Biochemical and Biophysical Research Communications* 528 (2), 261–268.

Ich versichere, dass ich alle Angaben wahrheitsgemäß nach bestem Wissen und Gewissen gemacht habe und verpflichte mich, jedmögliche, die obigen Angaben betreffenden Veränderungen, dem Promotionsausschuss unverzüglich mitzuteilen.

Köln, den 21.10.2020

Moyinoluwa Temitope Taiwo