

# Effect of Vaned Diffuser on the Performance of Small Turbocharger

Hilmi Amiruddin<sup>1,2\*</sup>, Wan Mohd Faizal Wan Mahmood<sup>1</sup>,  
Shahrir Abdullah<sup>1</sup>, Mohd Radzi Abu Mansor<sup>1</sup>,  
Mohd Fadzli Bin Abdollah<sup>2</sup>

<sup>1</sup>Faculty of Engineering & Built Environment,  
Universiti Kebangsaan Malaysia,  
43600 UKM Bangi, Selangor, Malaysia.

<sup>2</sup>Faculty of Mechanical Engineering,  
Universiti Teknikal Malaysia Melaka, Hang Tuah Jaya,  
76100 Durian Tunggal, Melaka, Malaysia

\*hilmi@utem.edu.my

Rizalman Mamat, Azri Alias  
Faculty of Mechanical Engineering,  
Universiti Malaysia Pahang, 26600 Pekan,  
Pahang, Malaysia.

## ABSTRACT

*This work presents an experimental investigation of performance of small turbocharger compressor with vaned diffuser. The aim of the study is to investigate the effect of number vaned diffuser on peak pressure ratio in turbocharger. The study was carried out using cold-flow turbocharger test rig driven by compressed air with the impeller rotational speed from 40,000 to 70,000 rpm. Tests were conducted with 6, 8 and 10 number of vanes while maintaining the vane blades angle of 6°, turning angle of 30° and blade length of 21.8 mm. The vanes as a flow deflector were designed as a thin flat plate of 1 mm thickness. All the results were compared with original vaneless diffuser of the compressor. The results found that the proposed design of 6 and 8 vanes shifted the peak pressure ratio toward low mass flow rate region. It was observed that modification from conventional vaneless diffuser compressor to the one equipped with vaned diffuser has significant improvement on the overall pressure ratio of the turbocharger.*

**Keywords:** Turbocharger; Vaned Diffuser, Compressor, Pressure Ratio

## Abbreviation

$l$	vane length (mm)	P	pressure
$\dot{m}$	mass flow rate (kg/s)	T	temperature
$n$	speed (rpm)	$\alpha$	flow angle ( $^{\circ}$ )
$r$	radius	$\beta$	blade angle ( $^{\circ}$ )
$s$	pitch (mm)	$\pi_c$	pressure ratio
$t$	vane thickness (mm)	$\theta$	blade turning angle ( $^{\circ}$ )
LSVD	low solidity vaned diffuser	1	impeller exit
N	number of vanes / blades	2	diffuser vane inlet
LE	leading edge	3	diffuser exit
TE	trailing edge		

## Introduction

Nowadays, engine downsizing using boosting device become the trends on improving fuel consumption due to global effort to reduce greenhouse gases (GHG) emission. In the recent years, small engine capacity with higher boost output turbocharger become important selling point for car manufacturers to achieve this global awareness. Centrifugal compressors are widely applied to automotive turbocharger due to their high single stage pressure ratio and wide operating range.

The main requirement for turbocharger compressor is to provide a high level of boost pressure and wide operating range. Generally, flow leaving the impeller has substantial kinetic energy and 30% to 50% of this energy could be efficiently recovered to pressure energy [1]. Vanes application in diffuser could provide an appropriate direction to the flow that leaving the impeller. In order to achieve good efficiency, as much as possible of this kinetic energy must be converted into the static pressure. Vanes in diffuser react as a deflector that help to reduce the fluid velocity and shortened the flow path.

The compressor operating range is limited at low flow rate by surge and at high flow rate by choke. Surge is a sudden high pressure flow reversal occurs in the compressor towards the inlet and potentially damaging all the compressor components. Conversely, choke is a condition which increase the mass of flow results in an extremely decrease in discharge pressure [2]. Most modern centrifugal compressors use backward-inclined bladed impeller to ensure best efficiency and broad operating range.

Many research that have been done to suppress the onset of the surge. Fixed geometry method [3-4] which used a casing treatments technique with slotted cover could eliminate the problem.

The used of vaned diffuser are known to give better performance in peak pressure ratio magnitude but could narrowing the operating range

comparing to vaneless diffuser. Harp and Oatway [5] used adjustable straight-wall wedge vanes to improve the operating range. Simon *et al.* [6] studied vanes diffuser with aerodynamically shape profiles and adjusted the vanes with the installation of variable inlet guide vanes. They concluded that the adjustment of the diffuser and inlet guide vane provided the expansion of operating range and increased the compressor efficiency. Casey and Rusch [7] carried out one-dimension analysis to estimate the performance map of impeller and vaned diffuser matching.

Application low-solidity vaned diffuser (LSVD) in compressor improved peak efficiency and operating range. Reddy *et al.* [8-9] concluded magnitude of blade angle ( $\beta$ ) in LSVD and number of vanes plays an important role in compressor operating range and pressure recovery performance. Engeda [10] studied the LSVD performance on turbocharger with simple flat plate vanes by changing the diffuser solidity, number of vanes (N) and vane turning angle ( $\theta$ ) for centrifugal compressor. He concluded that the flow range become wider with reduced solidities. Temel *et al.* [11] studied the flow performance condition between impeller and wedge type vaned diffuser with different flow angle.

Therefore, this study was to investigate the possibility of using vaned diffuser to improve the peak pressure ratio of conventional vaneless diffuser compressor in small turbocharger. Simple thin flat plate diffusers design was used in this experiment.

## Experimental Method

### Vaned Diffuser Design

The compressor used in this study had a vaneless diffuser with parallel wall. The impeller consists of six full length blades with six splitter blades. The diameter of the impeller was 60 mm with a backward-inclined blades style. The overall geometry of the compressor is given in Table 1. The original diffuser wall at hub surface was machined to allow the new vaned diffuser to be fitted. Guide pins were used to secure the diffuser onto the hub surface.

Table 1: Basic dimension of turbocharger.

Specification	Length (mm)
Impeller hub radius	7
Impeller inducer tip radius	21
Impeller discharge radius	30
Diffuser passage height	5
Radius of vaned diffuser leading edge	34.5
Radius of vaneless diffuser discharge	43.5

In this study the aluminium ring diffuser with 6, 8 and 10 number of blades were fabricated. All the diffusers have the same blade angle ( $\beta$ ) of  $6^\circ$ , blade turning angle ( $\theta$ ) of  $30^\circ$  and blade length ( $l$ ) of 21.8 mm. The leading edge (LE) of the blade was designed 4 mm from the impeller exit and trailing edge (TE) of the blades located at the diffuser exit. The blades thickness was designed about 1 mm thick. Figure 1 shows the dimension of the ring diffuser with 8 vanes. A dummy ring with no vanes was also fabricated to be used as an original vaneless diffuser.

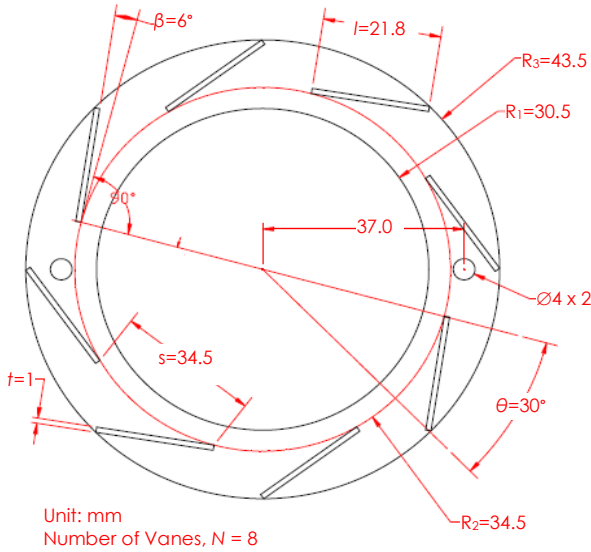

Figure 1: Dimension of diffuser with 8 vanes.

### Turbocharger Performance Test

Figure 2 shows the test rig schematic diagram used in this study. The test rig was operated in an open loop system and complied the recommended practice from SAE J1826 [12]. The turbine is driven by supply of high pressure air through a computer control valve (Valve 1). At the compressor exit, a control valve (Valve 3) was used to control the air flow rate. A vortex shedding flowmeter type was used to measure the flow rate at the exit of the compressor stage. A simple honeycomb flow straightener was installed in the piping at the discharge of the compressor volute in order to eliminate the swirl before entering the flowmeter. Pressure and temperature measurements were made at inlet and outlet of the compressor with calibrated pressure sensor and thermocouple.

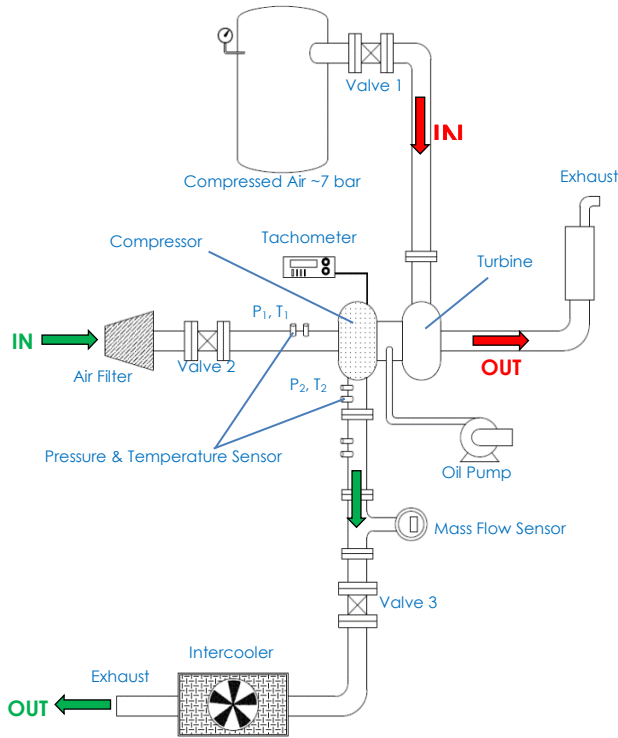

Figure 2: Test rig schematic diagram.

The performance of the compressor was tested at 40 000, 50 000, 60 000 and 70 000 rpm of impeller rotational speeds. The test was conducted by gradually reducing the air mass flow rate from the maximum to the surge flow condition. Computer control valve located after the compressor exit was adjusted in step manner in order to reduce the flow rate. The surge limits condition was observed through pressure sensor output and distinct sound.

Initially, the basic performance of a standard compressor with vaneless diffuser was obtained using dummy ring to simulate the original vaneless passage. This results were then compared with the performance of vaned diffusers installed at the diffuser of the compressor. Tests were performed with 6, 8 and 10 number of vanes.

The main parameter measured in this study is total pressure ratio. Total pressure ratio of the compressor was calculated by measuring the pressure value at compressor discharge to pressure at compressor inlet as in Eq. (1):

$$\pi_c = P_2/P_1 \quad (1)$$

Where  $P_1$  is compressor inlet pressure and  $P_2$  is compressor discharge pressure.

The corrected mass flow rate was calculated as in Eq. (2):

$$\dot{m}_{cor} = \dot{m} \sqrt{T_1/T_{ref}} / P_1/P_{ref} \quad (2)$$

Where is  $\dot{m}$  compressor mass flow,  $T_1$  is compressor inlet temperature,  $T_{ref}$  is compressor reference temperature and  $P_{ref}$  is compressor reference pressure.

## Results and Discussions

The performance of peak pressure ratio for all type of diffuser at different impeller speed is shown in Figure 3. Compressor with 6 and 8 vanes demonstrated a higher peak pressure ratio throughout the tested impeller speed over the conventional vaneless diffuser configuration. At 40,000 and 50,000 rpm, the peak pressure ratio produced almost identical for all type of vaned diffuser compared to vaneless diffuser. Within higher range of impeller speed of 60,000 and 70,000 rpm, the magnitude of peak pressure ratio for 6 and 8 vanes increased (Figure 3 (b) and (c)).

Results from 6 and 8 vanes also show the peak pressure ratio were shifted to a reduced flowrate area within same mass as compared to the vaneless diffuser type. This clearly shown by the surge line (dotted line) in Figure 3 which 6 and 8 vanes design formed more gradient line over vaneless diffuser. Furthermore, 6 and 8 vanes design show the pressure ratio increased steadily prior to surge.

Figure 4 shows all the different compressor type pressure ratio test results at designated test speed. At low speed of 40,000 and 50,000 rpm, the pressure ratio improvement can be considered fair over the vaneless diffuser. All the vaned diffuser modification produced higher pressure ratio throughout the operating range. At 60,000 rpm 6 vanes design improved pressure ratio at lower mass flow rate but reduced at higher mass flow rate compared to 8 vanes design (Figure 4 (c)). Results at 70,000 rpm shows 8 vanes design produced higher pressure ratio value compared others design all over the operating range (Figure 4 (d)).

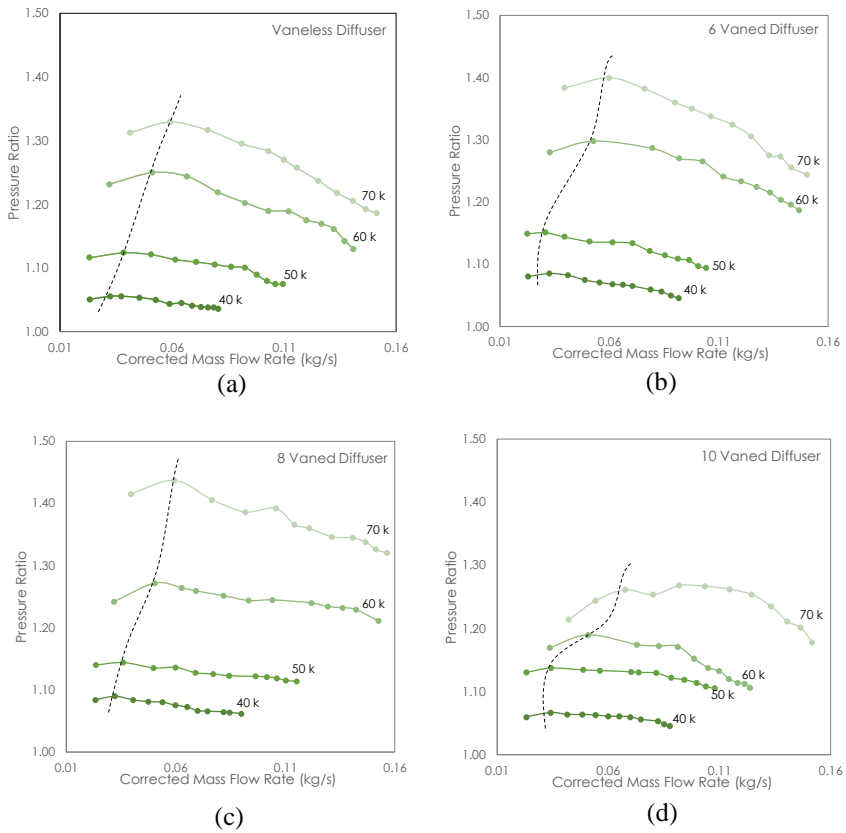

Figure 3: Peak pressure ratio of (a) vaneless diffuser, (b) 6 vaned diffuser, (c) 8 vaned diffuser and (d) 10 vaned diffuser

Compressor installed with 10 vanes diffuser shows poor results at the higher range of speed of 60 000 and 70 000 rpm. The pressure ratio produced even lower compared to vaneless diffuser. This lower pressure ratio condition is shown in Figure 4 (c) and (d). In addition, the 10 vanes diffuser design also reduce the operating range limits. This can be attributed to the ring diffuser design in which 10 vanes diffuser ring create such a cramped area within the diffuser and poor pressure recovery [8]. Therefore, when the impeller rotates at high speed to displace the air mass faster, the diffuser acts as blockage to the flow and produced great back pressure. This will lower the discharge pressure at the compressor exit.

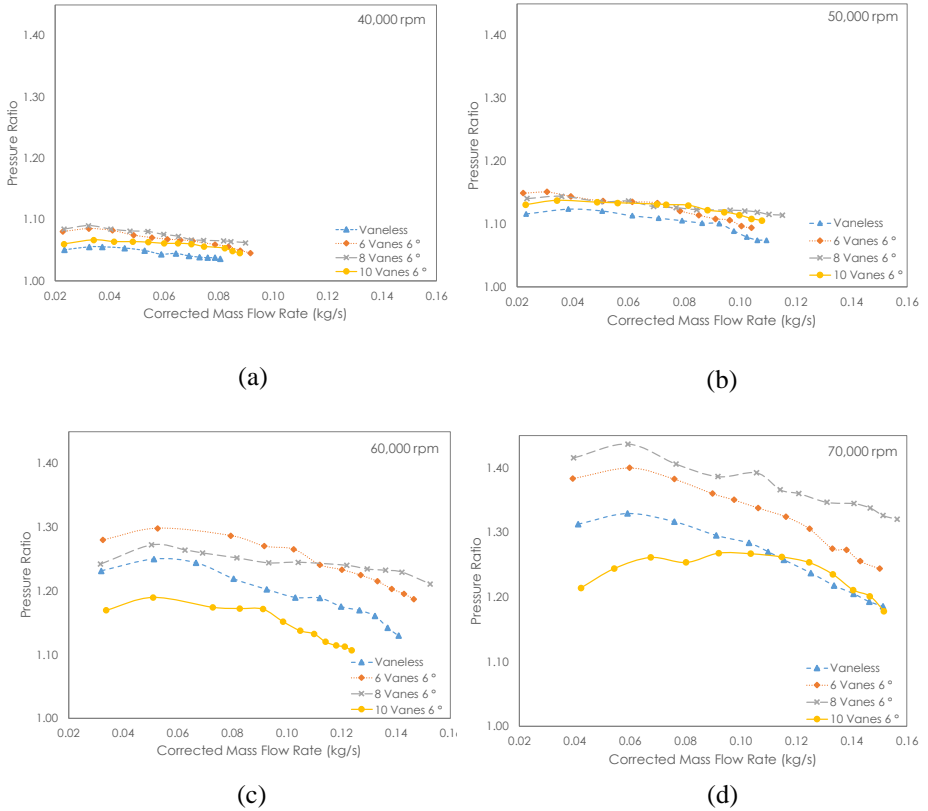

Figure 4: Comparison of diffusers pressure ratio tested at (a) 40,000 rpm, (b) 50,000 rpm, (c) 60,000 rpm and (d) 70,000 rpm.

## Conclusions

Experimental investigations have been conducted to evaluate the performance of small turbocharger compressor with vaned diffuser. The findings show that the use of the diffuser with 6 and 8 vanes increased the performance of the total pressure ratio and resulted a wider operating range compared to vaneless diffuser turbocharger. These diffusers also shifted the peak pressure ratio to the low flow rate condition compared to the vaneless type. As conclusion, the simple thin plate vaned diffuser application on centrifugal compressor in turbocharger potentially produce higher pressure ratio output for passenger vehicle turbocharger.



## Acknowledgement

This research was supported by the Ministry of Science, Technology and Innovation (grant number: 03-01-02 SF0995). The author Hilmi Amiruddin gratefully acknowledges the scholarship from Ministry of Higher Education Malaysia and Universiti Teknikal Malaysia Melaka (UTeM) for his Ph.D study. Further acknowledgement goes to the Faculty of Mechanical Engineering, Universiti Malaysia Pahang (UMP) for providing the cold-flow test rig facility.

## References

- [1] Baines. N.C., “Fundamentals of Turbocharging”, Concept NREC, 2005, pp. 61.
- [2] Gresh, M. T., “Compressor Performance Aerodynamics for the User”, Butterworth-Heinemann, 2001, pp. 34-35.
- [3] Tomita, I., An, B. and Nanbu, T. “A new operating range enhancement device combined with a casing treatment and inlet guide vanes for centrifugal compressors” *11th International Conference on Turbochargers and Turbocharging*, 2014, pp. 79-87.
- [4] Uchida, T., Kashimoto, A. and Iwakiri, Y. “Development of Wide Flow Range Compressor with Variable Inlet Guide Vane” *R&D Review of Toyota*, 2006, vol. 41 (3), 9-14.
- [5] Harp, J. and Oatway, T., "Centrifugal Compressor Development for a Variable Area Turbocharger", SAE Technical Paper 790066.
- [6] Simon, H., Wallman, T. and Mönk, T., “Improvement in Performance Characteristic of Single-Stage and Multistage Centrifugal Compressor by Simultaneous Adjustments of Inlet Guide Vanes and Diffuser Vanes”, *J. Turbomachinery*, 1987, vol. 109 (1), 41-47.
- [7] Casey, M. and Rusch, D., “The Matching of a Vaned Diffuser with a Radial Compressor Impeller and its Effect on the Stage Performance”, ASME Paper GT2014-25003, 2014.
- [8] Siva Reddy, T. Ch., Ramana Murty, G. V., Prasad, M. V. S. S. M., and Reddy, D. N., “Experimental studies on the effect of impeller width on centrifugal compressor stage performance with low solidity vaned diffuser” *Proc. Instn. Mech. Engrs, Proc. Instn. Mech. Engrs, Part A: J. of Power and Energy*, 2007, vol. 221, 519-533.
- [9] Siva Reddy, T. Ch., Ramana Murty, G. V., Mukkavilli, P., and Reddy, D. N., “Effect of the setting angle of a low solidity vaned diffuser on the performance of centrifugal compressor stage”, *Proc. Instn. Mech. Engrs, Part A: J. of Power and Energy*, 2004, vol. 218, 637-646.
- [10] Engeda, A., “Experimental and numerical investigation of the performance of a 240 kW centrifugal compressor with different

- diffusers”, *J. Experimental Thermal and Fluid Science*, 2003, vol. 28, 55-72.
- [11] Temel, U. N., Öztürk, A. and Pinerbasi, A., “Wedge type vane diffuser flow measurement in a low speed centrifugal compressor”, *J. of Scientific & Industrial Research*, vol. 67, pp. 788-796, 2008.
- [12] SAE International Surface Vehicle Recommended Practice, “Turbocharger Gas Stand Test Code”, SAE Standard J1826, Rev. March, 1995.