

SCO₂ POWER CYCLE DESIGN WITHOUT HEAT SOURCE LIMITATIONS: SOLAR THERMAL PARTICLE TECHNOLOGY IN THE CARBOSOLA PROJECT

Lukas Heller*

German Aerospace Center (DLR)
Stuttgart, Germany
Email: Lukas_Heller@gmx.de

Stefan Glos

Siemens Energy AG
Mülheim an der Ruhr, Germany

Reiner Buck

German Aerospace Center (DLR)
Stuttgart, Germany

ABSTRACT

Supercritical CO₂ power cycles have been proposed to lower the levelized cost of electricity generated by Concentrating Solar Power (CSP) plants due to their high thermal efficiency and low equipment cost. In this study, a simplified techno-economic model was developed to compare the performance of molten salt and solid particle CSP technologies with various sCO₂ cycle layouts and parameters. It was found that systems employing particle technology consistently have a lower levelized cost than molten salt systems, mainly due to the latter's high storage system cost, caused by a low temperature spread. Furthermore, less complex process layouts without reheat or intercooling and even without recompression render lower levelized cost, which is caused by increasing costs for compressors, motors and recuperators in high-performance layouts. Compared with the reference system based on a steam power block, the best sCO₂ processes achieve similar LCOE values but not the often-proposed significant improvements. These findings are highly dependent on some of the cost models, mainly for the primary heat exchanger and for indirect power block costs, which will be refined in a next step.

INTRODUCTION

Supercritical CO₂ (sCO₂) power cycles have the potential to reach considerably higher thermal efficiencies than state of the art steam cycles while minimizing the size and number of components. To reach high thermal efficiencies, the average temperature at which heat is supplied to the cycle has to be very high. Concentrating solar power (CSP) technology allows for this as the heat transfer medium downstream the sCO₂-primary heat exchanger is reintroduced into the solar receiver, making CSP-sCO₂ processes appear like a perfect match.

Unfortunately, heat transfer media used in commercial CSP plants have limiting upper and lower temperature constraints. Currently, the maximum temperature reached in these plants is approximately 565 °C for molten salt, which does not allow for using the most efficient high-temperature sCO₂ cycles.

Contrary to these state-of-the-art heat transfer media, certain ceramic particles have no temperature limitations within the

relevant technological range (0 °C... 1000 °C). This leads to the following potential advantages when combined with sCO₂ cycles:

- Very high temperature sCO₂ processes can be employed, leading to high thermal efficiencies.
- High approach temperatures to the primary heat exchanger (PHX) can be realized, leading to smaller heat transfer area requirements and, therefore, costs.
- Even when a small sCO₂ temperature rise is desired in the PHX in order to improve cycle efficiency, the temperature spread between hot and cold particles can still be kept comparatively large due to the high approach temperature. This temperature spread has a direct and significant effect on the cost of the thermal energy storage (TES) system cost [1].

Particle technology therefore allows for employing high temperature, highly recuperated sCO₂ power blocks (PBs) reaching thermal efficiencies in excess of 50 %. Although it is tempting to define a system for maximum efficiency, the choice should be based on the techno-economic optimum of the whole plant. The recompression cycle is commonly seen as the most efficient layout for an sCO₂ PB and has been proposed numerous times for integration with CSP [1-4]. Although this layout achieves high thermodynamic performance, it requires large and costly internal recuperators for this as well as a small temperature rise in the PHX. This leads to increased costs of the cycle equipment but also of the solar components, mainly the TES system. Due to their much lower cost, simple recuperated cycles, for example, have been found to be competitive on a techno-economic level [3, 5]. Other studies have found that, particularly for molten salt systems, partial cooling layouts can be beneficial as they increase the PHX temperature rise [6].

Besides the choice of the process layout, their main parameters (e.g. turbine inlet temperature, upper and lower cycle pressure, terminal temperature differences in all heat exchangers, ...) also have a strong impact on the cycle components' costs as well as on the solar components (via the PHX). This adds up to a large number of variables with non-obvious system-wide optima.

Table 1. Location and solar field assumptions

(*Adjusted for same annual energy yield as MS system)

(** Includes TES thermal losses and receiver limitations for min. load and startup)

dp: design point; a: annual

Parameter	Value	
	MS	Pa
Location	Postmasburg, RSA	
Design PB capacity (semi-net)	115 MW _e	
Design point ambient temperature	19 °C	
Solar multiple	2.4	~ 2.5*
TES capacity	12 h	
Collector field efficiency, dp	70 %	73.5 %
Collector field efficiency, a	58 %	52.7 %
Receiver efficiency, dp	Depending on cold tank temperature (~91.7 % @ 290 °C)	90 %
Receiver efficiency, a	Receiver efficiency, dp x 94.4 %	86.7 %
Dumping efficiency, a**	93 %	98 %
Plant gross-to-net	95 %	97.5 %
PB efficiency, a	PB efficiency,dp x 99 %	

Within Work Package 2 of the CARBOSOLA project, funded by the German Ministry for Economic Affairs and Energy, Siemens Energy and DLR are assessing the economic potential of sCO₂ cycles for CSP power plants. The present study concerns the initial step of this undertaking: the pre-selection of a small number of CSP technologies and sCO₂ processes, which are expected to have the highest techno-economic potential. The main areas described are the definition of investigated systems and boundary conditions, their thermodynamic modeling, economic models and, finally, results. The used models employ numerous simplifying assumptions due to the lack of maturity of, and therefore data for, the technologies. This is particularly true for the cost models of some major sCO₂ and particle components. In further works, the identified processes will be designed in more detail leading to improved cost and performance models.

BOUNDARY CONDITIONS AND DESCRIPTION OF INVESTIGATED SYSTEMS

The main boundary conditions for the modeled power plants are presented in Table 1. The location has been chosen because the Redstone Solar Power Plant is planned to be erected there and reference data exists from previous projects [7]. The location is noteworthy for a high annual direct normal irradiation (DNI) and rather moderate mean ambient temperatures.

Two different CSP technologies are investigated and modeled: State of the art molten salt (MS) and next-generation solid Particles (Pa). The maximum operating temperature of MS has been set to 565 °C. In a further variant, salt temperatures of up to 615 °C are assumed to be reachable although this has not yet been proven. This variant is meant to show the potential of sCO₂ cycles in combination with evolutions to the MS technology [7]. It was assumed that the MS receiver system operates at the same efficiency for all receiver outlet temperatures, which is obviously optimistic for the 615 °C case. The maximum particle temperature has been set to 900 °C in all variants.

All assumptions presented in Table 1 regarding the MS system (except for the receiver efficiency dependency on receiver inlet temperature, which is based on internal studies), were derived from a previous project [7]. The data for the Pa system is mainly based on internal studies at DLR for systems employing the CentRec© particle receiver. More information on the technology can be found in recent publications [1, 8]. The solar multiple, which is a measure for the oversizing of the solar field with respect to the steam generator, of the Pa systems was adjusted to render the identical annual electricity output as the MS systems.

TECHNO-ECONOMIC MODEL

The simplified annual yield model for the pre-selection process does not include hourly time steps for the performance calculation of the solar field but instead uses average annual values (shown in Table 1) for the subsystems. This allows for the comparison of the performance of tens of thousands of variants of the sCO₂ PB.

The subsystem costs for each variation of the PB or solar technology is calculated by setting the design point electricity yield (according to Table 1) and calculating the necessary rating of all subsystems via their design point efficiencies. This would result, e.g., in a larger solar field for a less efficient power block (all other efficiencies unchanged).

The focus of this study is the sCO₂ PB, its predicted performance and cost as well as the influence it has on the overall plant performance and cost. As mentioned above, the simplified model used here only requires a design-point simulation of the PB, meaning that part-load behavior is not modeled. The performance of the cycles and the rating of their components is calculated in the power plant simulation software Epsilon Professional V. 14.03 by STEAG Energy Services GmbH. Thermodynamic results were validated with data from the literature and very good agreement was found. Some of the major assumptions and ranges of optimization parameters are provided in Table 2.

Table 2: Assumptions and variables of sCO₂ cycles

Parameter	Value
$\Delta p_{\text{Recuperators (low pressure side)}}$	2 %
$\Delta p_{\text{Recuperators (high pressure side)}}$	3 %
Δp_{PHX}	2 %
$\Delta p_{\text{Cooler/IC}}$	0.6 %
$\eta_{\text{PHX,thermal}}$	99 %
$\eta_{\text{Turbines,isentropic}}$	91 %
$\eta_{\text{Compressors,isentropic}}$	87 %
$\eta_{\text{Motors,electric}}$	97 %
$\eta_{\text{Generator}}$	98.7 %
$\Delta p_{\text{air,Cooler/IC}}$	5 mbar
Turbine inlet pressure	260 bar
Turbine inlet temperature	500 °C ... 650 °C
$(U*A)_{\text{Cooler/IC}}$... 18 MW/K
Compressor inlet pressure	45 bar ... 100 bar
$TTD_{\text{Recuperator}}$	5 K ... 80 K
Recompression fraction	0.25 ... 0.45
$TTD_{\text{PHX,high-pressure}}$	5 K ... 195 K
$TTD_{\text{PHX, low-pressure}}$	5 K ... 195 K

Table 3: Overview of modeled process layouts

Name	Cycle type				RH	IC
	Simple Recuperated	Recompression	Partial cooling			
01_simple	x					
02_simple_RH	x				x	
03_simple_IC	x					x
04_simple_RH_IC	x				x	x
05_recomp		x				
06_recomp_RH		x			x	
07_recomp_IC		x				x
08_recomp_RH_IC		x			x	x
10_partialC			x			
09_partialC_RH			x	x		

A total of ten process layouts were modeled (see Table 3). They were simple recuperated cycles and recompression cycles with and without reheat (RH) or intercooling (IC) and partial cooling cycles with and without RH. Figure 1 depicts Layout 08 with those components marked that would fall away for layouts without RH (red), without IC (blue) and without recompression/partial cooling (green). The results in terms of efficiency and component rating were postprocessed to derive the overall system costs and levelized cost of electricity (LCOE) as the main optimization target.

The economic model contains specific costs for the main PB equipment, indirect costs as a percentage of the PB equipment

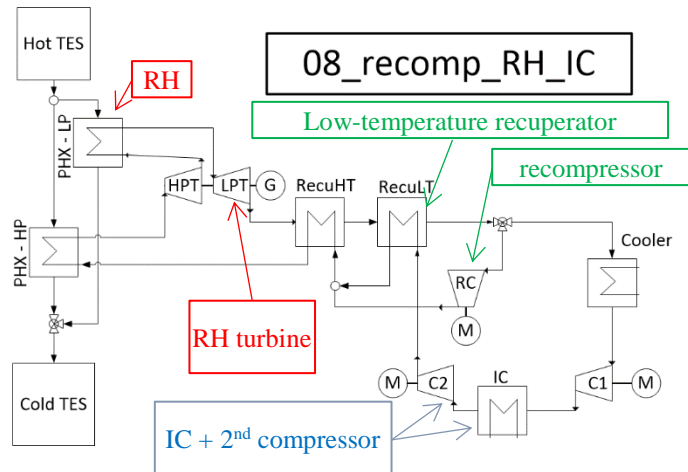

Figure 1: Schematic of an example process ("08")

costs and specific costs for all solar subsystems (see Annex A). Furthermore, EPC indirect costs and owner's costs are added to render the total owner's costs ($C_{\text{owner,total}}$). These are then used to calculate the LCOE via the following simplified correlation

$$LCOE = (FCR * C_{\text{owner,total}} + O\&M_a) / \sum P_{\text{out}}$$

Therein, FCR represents the fixed charge rate, $O\&M_a$ the annual operation and maintenance costs and $\sum P_{\text{out}}$ the cumulative annual electricity output of the plant.

Arguably the biggest challenge in assessing the techno-economic performance of a technology that has never been constructed (especially not at the considered scale) is to estimate the cost of its components, indirect costs and those for operation and maintenance. In very few sources in open literature are cost models for sCO₂ components over a range of operating parameters published. Recently, however, Weiland et al. [9] developed cost correlations for most major components of CSP-driven sCO₂ power blocks based on quotes from potential industrial suppliers. The equipment cost of all sCO₂ components, except for the primary heat exchanger, were calculated using these correlations. The cost of the Pa-PHX was calculated using a correlation proposed for particle-sCO₂ heat exchangers [1], which assumes high-grade materials that allow for high TITs. The MS-PHX cost correlation was derived from a study for molten salt systems operating at temperatures of up to 650 °C [6]. Once preliminary designs of the main components have been developed by Siemens Energy, these cost assumptions will be updated in a future study.

In order to compare the found results to the state of the art, the method described above was also used to calculate the performance of MS and Pa plants employing one of two different steam cycle PBs (with a turbine inlet temperature, TIT, of either 550 °C or 600 °C). As the variants with a TIT of 600 °C

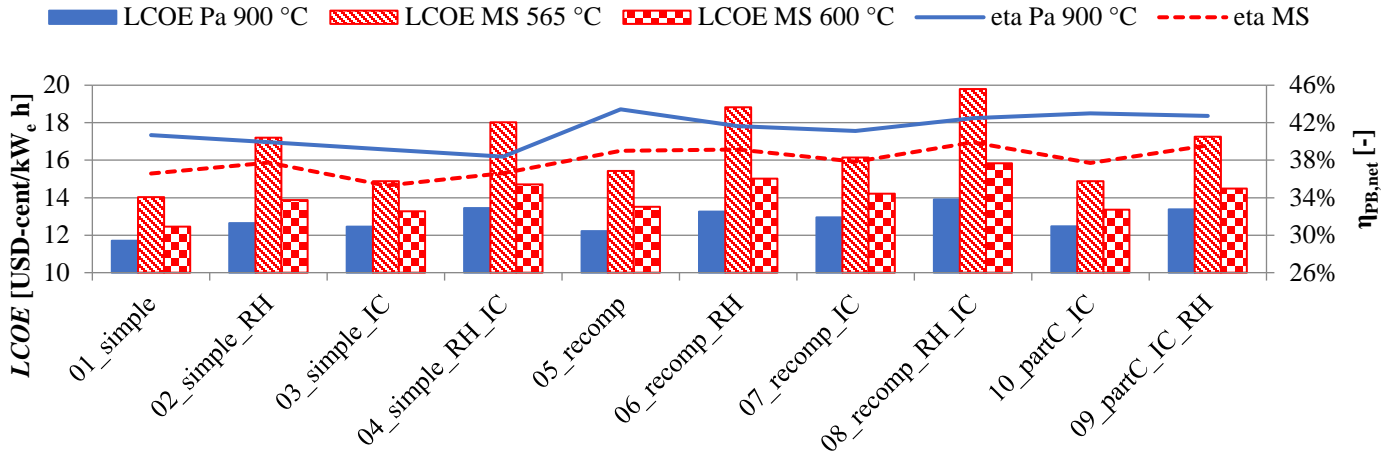

Figure 2: LCOE and PB efficiencies for cost optimized variants of all cycles and heat transfer media

produced similar LCOE values and Pa systems performed slightly better than MS systems, the Pa system with a TIT of 550 °C was chosen as the reference. It has a net PB efficiency of 42.7 % at an LCOE of 11.1 USD-cent/kW_e h.

RESULTS

Before discussing the quantitative results of the techno-economic analysis, it should once more be stressed that they should be seen as a qualitative indication only. The actual values for levelized cost of electricity are highly dependent on many assumptions, especially economic ones, which have a high uncertainty in this early development stage of the investigated technologies. That being said, the comparison of the processes with each other and with the reference steam system should give an indication for general trends and for which ones to pursue further.

At first, the simulated processes with the lowest LCOE were identified for each layout and each heat transfer medium. For these 30 variants, the LCOE and PB net efficiency are depicted in Figure 2. There are several observations to be made from this figure.

1. Electricity generated by Pa systems has the lowest cost for every layout. Even if the MS temperature can be increased to 615 °C without cost or performance penalties on the solar equipment, TES and PHX, the LCOE of MS systems is still higher than of Pa systems. The main cost drivers for this difference are the TES and the receiver system, as can be seen in Figure 3. Increasing the sCO₂ process temperature in MS systems, which would be possible for the 615 °C case, increases the cost of the TES system and the PHX even further (not shown in figure).
2. Due to the large influence of the TES cost on the MS systems, sCO₂ processes with a larger temperature rise in the PHX are preferred compared with Pa systems. Although they produce a lower PB efficiency for the MS systems (red dashed line) compared with the Pa configurations (blue solid line).

3. Less complex PB layouts produce a lower LCOE. This is especially true for the simple recuperated cycle without IC or RH (“01”).
4. The calculated LCOE of all systems is higher than that of the reference plant. Given the fidelity of the models, the difference lies within the range of uncertainty, though.
5. When optimized for LCOE, most configurations have a lower PB efficiency than the reference steam cycle (42.7 %). However, efficiency was not an objective in the optimization.

In Figure 4, the total cost of each Pa layout’s PB is further divided up into the main equipment and indirect costs. The top bar (“Rest + indirect”) includes mostly indirect costs of the power block (for civil works, instrumentation and control, electrotechnics, etc.) as well as contingencies & profit of the PB technology provider. These latter costs are calculated via cost adders on top of the total PB equipment costs and add up to 79 % (see also ANNEX A).

Another observation that can be made from Figure 4 is that the cost of the PHX is, with current cost models, of a comparable magnitude to that of all other PB equipment (excluding indirect costs). This is further discussed in the Conclusions and Outlook Section. Furthermore, the cost of the PB incl. PHX of all optimized systems is rather high, ranging from approximately 1300 USD/kW_e for Layout 01 to 2000 USD/kW_e for Layout 08. Commonly stated cost targets for sCO₂ cycles are much lower (~ 900 USD/kW_e) and the expected efficiencies considerably higher (> 45 %) [4, 10].

Besides indirect costs and the PHX, the dominating cost contributions stem from the recuperators, the compressors plus motors, the cooling system and piping, meaning that the turbine(s) only make up a small share of the total costs. One noteworthy trend is that the compressor plus motor costs increase significantly for more complex layouts. This is caused by the increased quantity of compressors from one unit (“01” & “02”) to two units (“03” through “06”) and three units (“07” through “10”). As the scaling exponent for compressor costs is very low, the quantity of units has a large influence on the equipment costs.

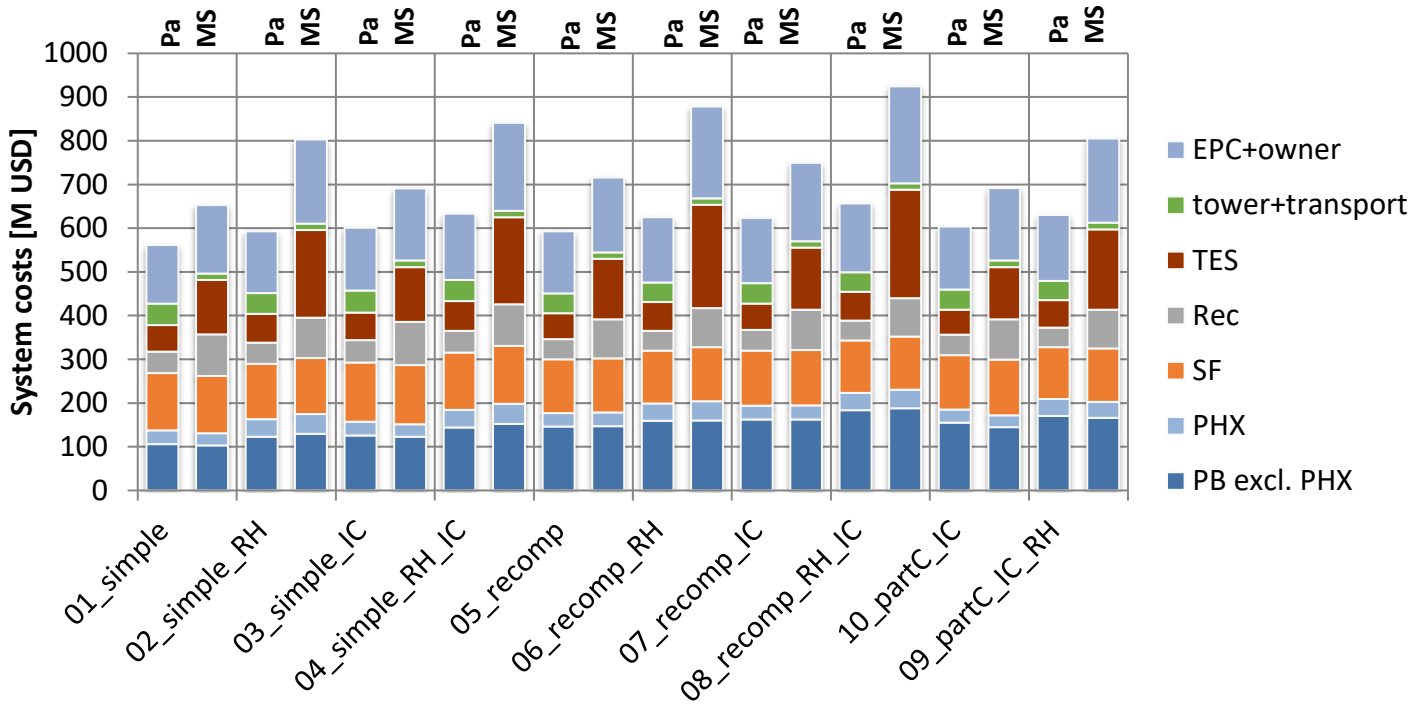

Figure 3: Subsystem costs of all layouts for Pa technology (left bars for every layout) and MS 565 °C systems (right bars)

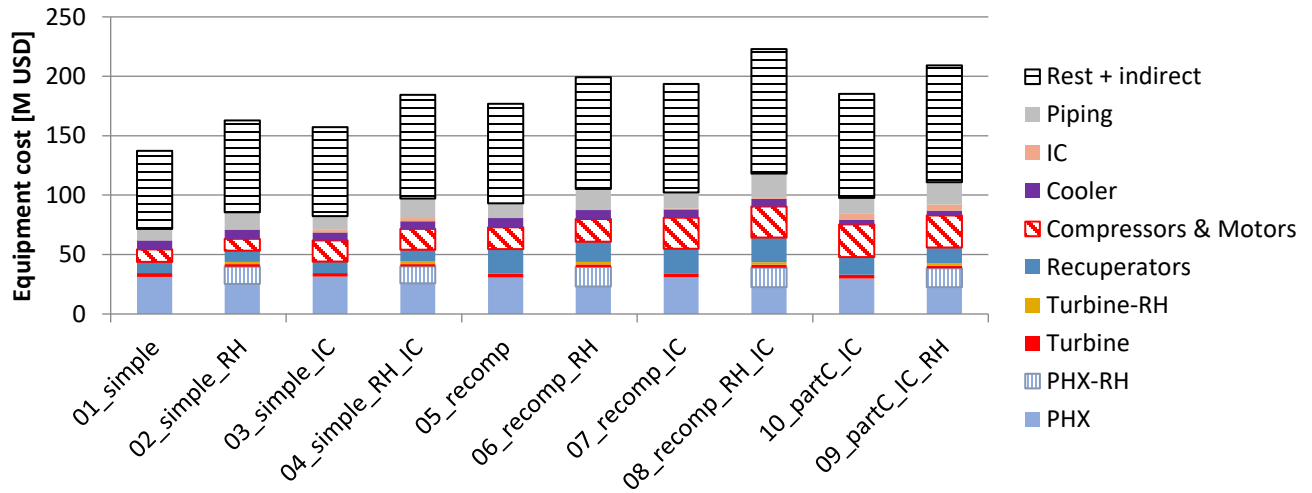

Figure 4: PB equipment costs of all variants employing particle technology and with a TIT of 550 °C

CONCLUSIONS AND OUTLOOK

There are three major conclusions to be drawn from the techno-economic optimization conducted in this study: Firstly, particle technology appears to be considerably more suitable for CSP-sCO₂ power plants compared with state-of-the-art molten salt or even an optimistic assumption for a system with evolutionary improvements. Therefore, molten salt systems are not pursued any more within the CARBOSOLA project, focusing entirely on particle technology.

Secondly, the comparison of different LCOE-optimized variants of sCO₂ processes showed that simpler layouts with fewer components are more economical than more efficient but more expensive ones. The simple recuperated cycle without reheat or intercooling showed consistently the best economic performance. Some of the subsystems and equipment contributing majorly to this trend are the TES, compressors, recuperators and piping. It can be concluded that the cost savings due to a larger temperature spread in the TES system outweigh the additional cost of an increased heliostat field.

Thirdly, all investigated sCO₂ processes render higher LCOE values than the steam reference plant, however, the best-performing cycles come close. This is in contrast to expectations that this new technology can provide very high thermal efficiencies at significantly lower PB investment cost than the state of the art. While some other studies have found comparable LCOE or specific costs for CSP plants with steam and sCO₂ power blocks [5, 11], others predict very low LCOE values for sCO₂-based plants [1, 4, 12, 13].

For this large discrepancy, several possible explanations come to mind. Many studies appear to assume much lower (or no) indirect costs associated with the power block equipment. As there is a cost adder of 79 % for these used in the current study, the PB cost would be almost doubled compared with those models. Lowering this factor would obviously improve the comparison with steam cycles.

An explanation for the rather high LCOE values found for all sCO₂ variants but also for the reference system are conservative assumptions in the financial model. The used values for the fixed charge rate of 9.37 % might be conservative but does not seem unrealistic.

Finally, the implemented Pa-PHX cost model was derived for very high temperature processes and might, therefore, also be conservative for the modeled process parameters. An appropriate cost reduction term for lower sCO₂ process temperature, e.g. a TIT of 550 °C, could have a significant impact on the equipment costs but also the overall plant performance. Much more optimistic cost correlation for Pa-sCO₂ heat exchangers can be found in the literature [3].

The next step within the Carbosola Project is the preliminary design of core components of sCO₂ power blocks. Findings from that work will help improve the presented models and validate the findings.

NOMENCLATURE

CSP	Concentrating solar power
IC	Intercooling
MS	Molten salt technology system
Pa	Particle technology system
PB	Power block
PHX	Primary heat exchanger
RH	Reheat
sCO ₂	Supercritical CO ₂
TES	Thermal energy storage
TIT	Turbine inlet temperature
<i>LCOE</i>	Levelized cost of electricity (USD/kW h)
<i>P</i>	Electric Power (W _e)
<i>TTD</i>	Terminal temperature difference (K)
<i>U*A</i>	Heat exchanger conductance-area product (W/K)
Δp	Relative pressure drop (%)
η	Efficiency (%)

ACKNOWLEDGEMENTS

The authors would like to thank the German Federal Minister for Economic Affairs and Energy for the financial

support of the project Carbosola (reference number: 03EE5001C).

REFERENCES

1. Buck, R. and S. Giuliano, *Impact of solar tower design parameters on sCO₂-based solar tower plants*. 2nd European sCO₂ Conference 2018: 30-31 August 2018, Essen, Germany, 2018: p. 160-167.
2. Dyreby, J., et al., *Design Considerations for Supercritical Carbon Dioxide Brayton Cycles With Recompression*. Journal of Engineering for Gas Turbines and Power, 2014. **136**(10).
3. Ho, C.K., et al., *Technoeconomic Analysis of Alternative Solarized s-CO₂ Brayton Cycle Configurations*. Journal of Solar Energy Engineering, 2016. **138**(5).
4. Albrecht, K.J., M.L. Bauer, and C.K. Ho. *Parametric Analysis of Particle CSP System Performance and Cost to Intrinsic Particle Properties and Operating Conditions*. in *ASME 2019 13th International Conference on Energy Sustainability collocated with the ASME 2019 Heat Transfer Summer Conference*. 2019.
5. Crespi, F.M., *Thermo-economic assessment of supercritical CO₂ power cycles for concentrated solar power plants*, in *Department of Energy Engineering School of Engineering - ETSI*. 2019, University of Seville: Seville.
6. Neises, T. and C. Turchi, *Supercritical carbon dioxide power cycle design and configuration optimization to minimize levelized cost of energy of molten salt power towers operating at 650 °C*. Solar Energy, 2019. **181**: p. 27-36.
7. Giuliano, S., et al., *HPMS - High Performance Molten Salt Tower Receiver System*. 2017.
8. Ebert, M., et al., *Operational experience of a centrifugal particle receiver prototype*. 2019. **2126**(1): p. 030018.
9. Weiland, N.T., B.W. Lance, and S.R. Pidaparti. *sCO₂ Power Cycle Component Cost Correlations From DOE Data Spanning Multiple Scales and Applications*. in *ASME Turbo Expo 2019: Turbomachinery Technical Conference and Exposition*. 2019.
10. Vijaykumar, R.B., Matthew L.; Lausten, Mark; Shultz, Abraham M., *Optimizing the Supercritical CO₂ Brayton Cycle for Concentrating Solar Power Application*, in *The 6th International Supercritical CO₂ Power Cycles Symposium*. 2018: Pittsburgh, Pennsylvania.
11. Cheang, V.T., R.A. Hedderwick, and C. McGregor, *Benchmarking supercritical carbon dioxide cycles against steam Rankine cycles for Concentrated Solar Power*. Solar Energy, 2015. **113**: p. 199-211.
12. Mecheri, M., Z. Qiao Dr, and P.F. nd European supercritical Co2 Conference September, *Probabilistic technique for solving computational problem:*

application of Ant Colony Optimization (ACO) to find the best sCO₂ Brayton cycle configuration. 3rd European Conference on Supercritical CO₂ (sCO₂) Power Systems 2019: 19th-20th September 2019, 2019: p. 319-331.

13. Trevisan, S., R. Guédez, and B. Laumert, *Thermo-economic optimization of an air driven supercritical CO₂ Brayton power cycle for concentrating solar power plant with packed bed thermal energy storage.* Solar Energy, 2020. **211**: p. 1373-1391.

ANNEX A

COST MODELS AND ECONOMIC ASSUMPTIONS

$$C_{\text{Component}} = f_T(a + b * x^c)$$

Component	f_T (for $t_{\text{fluid,max}} > 550 \text{ }^\circ\text{C}$)	a	b	c	x	Source
PHXs			3266.8 USD	0.66	$UA_{\text{PHX}}/(\frac{W_t}{K})$	based on [1]
Turbines	$1 + 1.106\text{E-}04 * (t_{\text{fluid,max}} - 550 \text{ }^\circ\text{C})^2$		182 600 USD	0.5561	$P_{\text{shaft}}/\text{MW}_t$	[9]
Generator			108 900 USD	0.5463	$P_{\text{electric}}/\text{MW}_e$	
Compressors			6 220 000 USD	0.1114	$\dot{V}_{\text{inlet}}/(\frac{\text{m}^3}{\text{s}})$	
Motors			399 400 USD	0.6062	$P_{\text{electric}}/\text{MW}_e$	
Recuperators	$1 + 0.02414 * (t_{\text{fluid,max}} - 550 \text{ }^\circ\text{C})$		49.45 USD	0.7544	$UA_{\text{PHX}}/(\frac{W_t}{K})$	
ACC			32.88 USD	0.75	$UA_{\text{PHX}}/(\frac{W_t}{K})$	

\dot{V} : Volume flow (m^3/s)

Item	Value	Reference quantity
sCO ₂ storage	2 000 000 USD	-
Piping + valves (excl. RH piping)	15 %	PB equipment cost
RH piping	5 %	PB equipment cost
PB indirect costs* + technology provider services, profit and contingencies	79 %	PB direct cost
EPC services and contingencies + owner's cost	29 %	Total power plant direct cost

*Includes: Electronics; Instrumentation & Control; Construction, Commissioning, Project Management; Civil works; Engineering; Auxiliary systems

Parameter	Value	Reference	Comment
FCR	9.37 %	Total power plant investment cost	Fixed charge rate, derived for an interest rate of 8 % and a plant lifetime of 25 years.
$O\&M_a$	2 %	Total power plant direct cost	Annual operating and maintenance cost

DuEPublico

Duisburg-Essen Publications online

UNIVERSITÄT
DUISBURG
ESSEN

Offen im Denken

ub

universitäts
bibliothek

Published in: 4th European sCO₂ Conference for Energy Systems, 2021

This text is made available via DuEPublico, the institutional repository of the University of Duisburg-Essen. This version may eventually differ from another version distributed by a commercial publisher.

DOI: 10.17185/duepublico/73961

URN: urn:nbn:de:hbz:464-20210330-104900-9



This work may be used under a Creative Commons Attribution 4.0 License (CC BY 4.0).