

Budownictwo i Architektura 19(4) 2020, 85-94
DOI: 10.35784/bud-arch.2131

Received: 30.01.2020; Revised: 03.06.2020;
Accepted: 03.06.2020; Available online: 02.11.2020



Original Article

© 2020 Budownictwo i Architektura

This is an open-access article distributed under the terms of the CC-BY-SA 3.0

Assessment of the early-age strains and stresses in 2D restrained self-stressed members

Viktar V. Tur^{1,2}, Volha H. Sannikava³

¹ Department of Concrete Technology and Building Materials; Faculty of Civil Engineering;
Brest State Technical University; 267 Moskovskaya Street, 224017 Brest, Belarus;
profturvic@gmail.com  0000-0001-6046-1974

² Department of Building Structures; Faculty of Civil and Environmental Engineering;
Bialystok University of Technology; 45 E Wiejska Street; 15-034; Bialystok, Poland

³ Department of Geotechnics and Transport Communications; Faculty of Civil Engineering;
Brest State Technical University; 267 Moskovskaya Street, 224017 Brest, Belarus; volhasann@gmail.com

Abstract: The paper presents the implementation of the modified strains development model (MSDM) for the two-way restrained self-stressed members such as expansive concrete-filled steel tubes and expansive concrete plane elements with arbitrary orthogonal reinforcement. The analytical approach allows defining the restrained strains and stresses in any 2D restraint conditions by following the iterative procedures and accounting for the elastic-plastic behaviour of expansive concrete at an early age. The consistency of the proposed method was confirmed by assessing the experimental results of the two series of the expansive concrete-filled steel tubes and three series of the expansive concrete plane members with mesh reinforcement in the centre of gravity.

Keywords: expansive concrete, strains, stresses, restraint conditions, analytical model

1. Introduction

The actual design models predict the stress-strain parameters of the expansive concrete elements under biaxial restraint conditions in a variety of ways. All known approaches can be grouped against the basic concept as follows: a) models based on the chemical energy conservation law [1]–[5]; b) empirical exponential function models [6], [7]; c) semi-empirical models [8]; d) fuzzy inference system model (FIS) [9]. It is noticeable, that majority of models ignore the elastic-plastic behaviour of the expansive concrete elements under confinements during the hydration period as well as different boundary conditions in the wide range of self-stressing elements [1]–[7]. In most cases, design models allow defining the restrained expansion strains only by the end of the expansive concrete stabilization period ignoring the development of ones at an early age of expansive concrete [1]–[7]. Moreover, in case of models based on the chemical energy conservation law, for example, the design self-stress of expansive concrete is considered

as a basic parameter while a different correlation between the values of free expansion strains and self-stressing grade arises [1]–[5]. It should also be noted, that all design methods contain the empirical coefficients that are based on the restricted experimental data so the incorrect results can arise concerning the wide range of expansive concrete elements under 2D confinement.

Thus the development of a comprehensive calculation method for the estimation the restrained expansion strains and stresses is an important problem during the design of expansive concrete elements under 2D restraint conditions.

2. The modified strain development model for the biaxial restraint conditions

2.1. The modified strains development model for the case of uniaxial restraint conditions (MSDM)

The most efficient calculation method for the estimation of the restrained expansion strains and stresses has been presented in the research paper [10] for the case of uniaxial restraint conditions. When the elastic-plastic parameters of the expansive concrete at an early age are taken into consideration, the restrained expansion strain in the x-direction at the i -th time interval is expressed as follows:

$$\varepsilon_{s,x}(t_{i+1/2}) = \sum_{j=1}^i \left[(\Delta\sigma_{c,x})_j \cdot J(t_{i+1/2}, t_j) \right] + \varepsilon_{cf}(t_{i+1/2}, t_{1/2}) \quad (1)$$

where:

$(\Delta\sigma_{c,x})_j$ – incremental self-stress in the x-direction at the j -th time interval;

$\varepsilon_{cf}(t_{i+1/2}, t_{1/2})$ – the difference of the free strain due to the temperature change and shrinkage or expansion of the expansive concrete in the x-direction from the time interval $t_{1/2}$ to the $t_{i+1/2}$;

$J(t_{i+1/2}, t_j)$ – creep compliance function.

Based on the above model, the modified early age strains development model (MSDM) for the case of uniaxial restraint, arrangements have been worked out [11]. The distinctive idea of MSDM concerns the presence of cumulative elastic force induced by the restraint at the end of the preceding time interval. The mentioned cumulative force accounts for the additional confinement of concrete expansion which is especially noticeable in case of high level of restraint in elements with high energy capacity of expansive concrete.

According to the MSDM for expansive concrete elements under uniaxial restraint conditions, the restrained expansion strain at any i -th time interval $\varepsilon_s(t_{i+1/2})$ can be performed as an algebraic sum of free expansion strain $\varepsilon_{cf}(t_{i+1/2})$, elastic strain at an i -th time interval $\varepsilon_{el}(t_{i+1/2})$, creep strain at i -th time interval under constant self-stress applied at t_0 days $\varepsilon_{pl}(t_{i+1/2}, t_0)$ and additional strain $\varepsilon_{cum}(t_{(i-1)+1/2})$ caused by the restrictive force induced by the restraint at $(i-1)$ -th time interval:

$$\varepsilon_s(t_{i+1/2}) = \varepsilon_{cf}(t_{i+1/2}) + \varepsilon_{el}(t_{i+1/2}) + \varepsilon_{pl}(t_{i+1/2}, t_0) + \varepsilon_{cum}(t_{(i-1)+1/2}) \quad (2)$$

2.1. The modified early age strains development model for the case of biaxial restraint conditions

This paper presents the calculation model for assessment the restrained expansion strains in expansive concrete elements under 2D restraint conditions that is based on the modified strains development model (MSDM) for the case of uniaxial reinforcement arrangement.

The main assumptions of the proposed model are as follows:

1. confinement in orthogonal directions is considered utilizing the Poisson's ratio of early age expansive concrete $\nu = 0.2$ concerning the elastic strain at an i -th time interval ($\varepsilon_{el,x}(t_{i+1/2})$ in x-direction, $\varepsilon_{el,y}(t_{i+1/2})$ in y-direction);
2. restrained expansion strain at any i -th time interval in the directions x and y is an algebraic sum of free expansion strain ($\varepsilon_{cf}(t_{i+1/2})$), elastic strain ($\varepsilon_{el,x}(t_{i+1/2})$ in x-direction, $\varepsilon_{el,y}(t_{i+1/2})$ in y-direction), creep strain ($\varepsilon_{pl,x}(t_{i+1/2}, t_0)$ in x-direction, $\varepsilon_{pl,y}(t_{i+1/2}, t_0)$ in y-direction) at i -th time interval and additional strain caused by the restrictive force induced by the restraint ($\varepsilon_{cum,x}(t_{(i-1)+1/2})$ in x-direction, $\varepsilon_{cum,y}(t_{(i-1)+1/2})$ in y-direction) at $(i-1)$ -th time interval:

$$\begin{cases} \varepsilon_{s,x}(t_{i+1/2}) = \varepsilon_{cf}(t_{i+1/2}) + [\varepsilon_{el,x}(t_{i+1/2}) - \nu \cdot \varepsilon_{el,y}(t_{i+1/2})] + \varepsilon_{pl,x}(t_{i+1/2}, t_0) + \varepsilon_{cum,x}(t_{(i-1)+1/2}) \\ \varepsilon_{s,y}(t_{i+1/2}) = \varepsilon_{cf}(t_{i+1/2}) + [\varepsilon_{el,y}(t_{i+1/2}) - \nu \cdot \varepsilon_{el,x}(t_{i+1/2})] + \varepsilon_{pl,y}(t_{i+1/2}, t_0) + \varepsilon_{cum,y}(t_{(i-1)+1/2}) \end{cases} \quad (3)$$

3. equilibrium condition between resultant forces in restrictive reinforcement and expansive concrete section takes place because of the bond conditions in directions x and y at any i -th time interval.

The restrained expansion strains in x-direction and y-direction are calculated in accordance with the following expression:

$$\begin{cases} (\Delta\varepsilon_{s,x})_i = (\Delta\varepsilon_{cf})_i - [(\Delta\sigma_{c,x})_i - \nu \cdot (\Delta\sigma_{c,y})_i] \cdot J(t_{i+1/2}, t_i) - \\ - \sum_{j=1}^{i-1} \left[(\Delta\sigma_{c,x})_j \cdot \frac{\Delta\varphi(t_i, t_j)}{E_{c,28}} \right] - \frac{\sum_{j=1}^{i-1} (\Delta\sigma_{c,x})_j}{E_c(t_{(i-1)+1/2})} \\ (\Delta\varepsilon_{s,y})_i = (\Delta\varepsilon_{cf})_i - [(\Delta\sigma_{c,y})_i - \nu \cdot (\Delta\sigma_{c,x})_i] \cdot J(t_{i+1/2}, t_i) - \\ - \sum_{j=1}^{i-1} \left[(\Delta\sigma_{c,y})_j \cdot \frac{\Delta\varphi(t_i, t_j)}{E_{c,28}} \right] - \frac{\sum_{j=1}^{i-1} (\Delta\sigma_{c,y})_j}{E_c(t_{(i-1)+1/2})} \end{cases} \quad (4)$$

where:

$(\Delta\sigma_{c,x})_j$ and $(\Delta\sigma_{c,y})_j$ – incremental self-stress in the x-direction and the y-direction correspondingly at the j -th time interval;

$(\Delta\varepsilon_{cf})_i$ – incremental free strain of expansive concrete at the i -th time interval;

$E_{s,x}$ and $E_{s,y}$ – Young's modulus of reinforcement in the x-direction and the y-direction correspondingly;

$\rho_{s,x}$ and $\rho_{s,y}$ – reinforcement ratio in the x-direction and the y-direction correspondingly.

It can be noted that in formula (4) the values of self-stresses $(\Delta\sigma_{c,x})_j$ and $(\Delta\sigma_{c,y})_j$ at the j -th time interval have already been obtained, taking into account the Poisson's ratio of expansive concrete.

Because of the bond conditions, the expansive concrete and the reinforcement deform compatibly. Thus the incremental self-stresses at the i -th time interval in the principal axes directions are calculated by:

$$\begin{cases} (\Delta\sigma_{c,x})_i = (\Delta\varepsilon_{s,x})_i \cdot E_{s,x} \cdot \rho_{s,x} \\ (\Delta\sigma_{c,y})_i = (\Delta\varepsilon_{s,y})_i \cdot E_{s,y} \cdot \rho_{s,y} \end{cases} \quad (5)$$

where:

$(\Delta\varepsilon_{s,x})_i$ and $(\Delta\varepsilon_{s,y})_i$ – incremental restrained expansion strains at the i -th time interval in the x-direction and y-direction correspondingly.

The values of the restrained expansion strains and stresses in the x-direction and y-direction at a given time interval are obtained as follows:

$$\left\{ \begin{array}{l} (\varepsilon_{s,x})_i = (\varepsilon_{s,x})_{i-1} + (\Delta\varepsilon_{s,x})_i \\ (\varepsilon_{s,y})_i = (\varepsilon_{s,y})_{i-1} + (\Delta\varepsilon_{s,y})_i \end{array} \right\}; \left\{ \begin{array}{l} (\sigma_{c,x})_i = (\sigma_{c,x})_{i-1} + (\Delta\sigma_{c,x})_i \\ (\sigma_{c,y})_i = (\sigma_{c,y})_{i-1} + (\Delta\sigma_{c,y})_i \end{array} \right. \quad (6)$$

The iterative calculation continues until the end of the expansive concrete stabilization period.

2.2. The modified early age strains development model for the case of the steel tube symmetrical restraint conditions

Based on the assumptions [11], [12], for the case of the steel tube symmetrical restraint arrangement (see Fig. 1), the basic equations for calculating of the incremental restrained strains in the circumferential direction $(\Delta\varepsilon_{s,\theta})_i$ and the axial direction $(\Delta\varepsilon_{s,z})_i$ at any i -th time interval with regard to the vertical reaction can be expressed as follows:

$$\left\{ \begin{array}{l} (\Delta\varepsilon_{s,\theta})_i = (\Delta\varepsilon_{cf})_i - (\Delta\sigma_{c,\theta})_i \cdot J(t_{i+1/2}, t_i) - \sum_{j=1}^{i-1} \left[(\Delta\sigma_{c,\theta})_j \cdot \frac{\Delta\varphi(t_i, t_j)}{E_{c,28}} \right] - \frac{\sum_{j=1}^{i-1} (\Delta\sigma_{c,\theta})_j}{E_c(t_{(i-1)+1/2})} \\ (\Delta\varepsilon_{s,z})_i = (\Delta\varepsilon_{cf})_i - (\Delta\sigma_{c,z})_i \cdot J(t_{i+1/2}, t_i) - \sum_{j=1}^{i-1} \left[(\Delta\sigma_{c,z})_j \cdot \frac{\Delta\varphi(t_i, t_j)}{E_{c,28}} \right] - \frac{\sum_{j=1}^{i-1} (\Delta\sigma_{c,z})_j}{E_c(t_{(i-1)+1/2})} \end{array} \right. \quad (7)$$

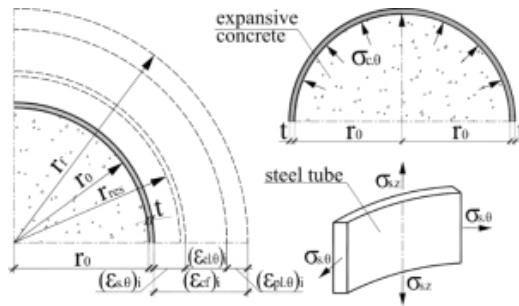

Fig. 1. 2D symmetrical restraint in case of the expansive concrete-filled steel tube. *Source:* own study

Incremental self-stresses can be calculated according to the expressions:

$$\left\{ \begin{array}{l} (\Delta\sigma_{c,\theta})_i = \frac{t}{r_0} \frac{E_s}{(1-\nu_s^2)} [(\Delta\varepsilon_{s,\theta})_i + \nu_s (\Delta\varepsilon_{s,z})_i] \\ (\Delta\sigma_{c,z})_i = \frac{2t}{r_0} \frac{E_s}{(1-\nu_s^2)} [(\Delta\varepsilon_{s,z})_i + \nu_s (\Delta\varepsilon_{s,\theta})_i] \end{array} \right. \quad (8)$$

where:

E_s – modulus of elasticity of steel tube;

ν_s – Poisson's ratio of steel tube;

r_0 – initial radius of steel tube;

t – thickness of steel tube.

Substituting Eq.(8) in Eq. (7), incremental restrained expansion strains $(\Delta\varepsilon_{s,\theta})_i$ and $(\Delta\varepsilon_{s,z})_i$ at any i -th time interval are expressed as follows:

$$\left\{ \begin{array}{l} (\Delta\varepsilon_{s,\theta})_i = (\Delta\varepsilon_{cf})_i - \frac{t}{r} \frac{E_s}{(1-\nu_s^2)} [(\Delta\varepsilon_{s,\theta})_i + \nu_s (\Delta\varepsilon_{s,z})_i] \cdot J(t_{i+1/2}, t_i) - \\ - \sum_{j=1}^{i-1} \left[(\Delta\sigma_{c,\theta})_j \cdot \frac{\Delta\varphi(t_i, t_j)}{E_{c,28}} \right] - \frac{\sum_{j=1}^{i-1} (\Delta\sigma_{c,\theta})_j}{E_c(t_{(i-1)+1/2})} \\ (\Delta\varepsilon_{s,z})_i = (\Delta\varepsilon_{cf})_i - \frac{2t}{r_0} \frac{E_s}{(1-\nu_s^2)} [(\Delta\varepsilon_{s,z})_i + \nu_s (\Delta\varepsilon_{s,\theta})_i] \cdot J(t_{i+1/2}, t_i) - \\ - \sum_{j=1}^{i-1} \left[(\Delta\sigma_{c,z})_j \cdot \frac{\Delta\varphi(t_i, t_j)}{E_{c,28}} \right] - \frac{\sum_{j=1}^{i-1} (\Delta\sigma_{c,z})_j}{E_c(t_{(i-1)+1/2})} \end{array} \right. \quad (9)$$

3. Verification of the modified strain development model for the biaxial restraint conditions

3.1. Expansive concrete plane elements with arbitrary orthogonal restraint

Three series of the expansive concrete plane specimens with the mesh reinforcement in the mid-depth of the cross-section were investigated during the expansive concrete hydration period. The rate of confinement in the orthogonal directions was taken as the variable parameter of test samples.

Geometry and characteristics of reinforcement and expansive concrete of the test elements are presented in the Table 1.

Table 1. Geometry and material characteristics of plane specimens. *Source:* own study

Specimen marking	Specimen geometry, mm, $b \times l \times h$	Reinforcement				Expansive concrete	
		x-direction	reinforcement ratio $\rho_{s,x}$, %	y-direction	reinforcement ratio $\rho_{s,y}$, %	ε_{cf} , %	$E_{c,28}$, GPa
P1		339	0.97	58.9	0.16	0.117	42.66
P2	500x500x70	339	0.97	339	0.97	0.437	23.1
P3		58.9	0.16	58.9	0.16	0.334	33.3

$A_{s,x}$ – reinforcement area in the x-direction; $A_{s,y}$ – reinforcement area in the y-direction; ε_{cf} – free strain at the concrete expansion stabilization; $E_{c,28}$ – Young's modulus at 28 days age.

Development of the experimental values of the restrained expansion strains during the hydration period along with the calculated according to the 2D MSDM ones for the test specimens

is shown in Fig. 3. In the same Figure, the calculated according to the model [10] data are also shown to demonstrate the influence of additional cumulative force on the restrained expansion strains. It should be pointed out that the calculation of the stress-strain parameters following model [10] was carried out, taking into account the Poisson's ratio concerning the elastic part of concrete deformation.

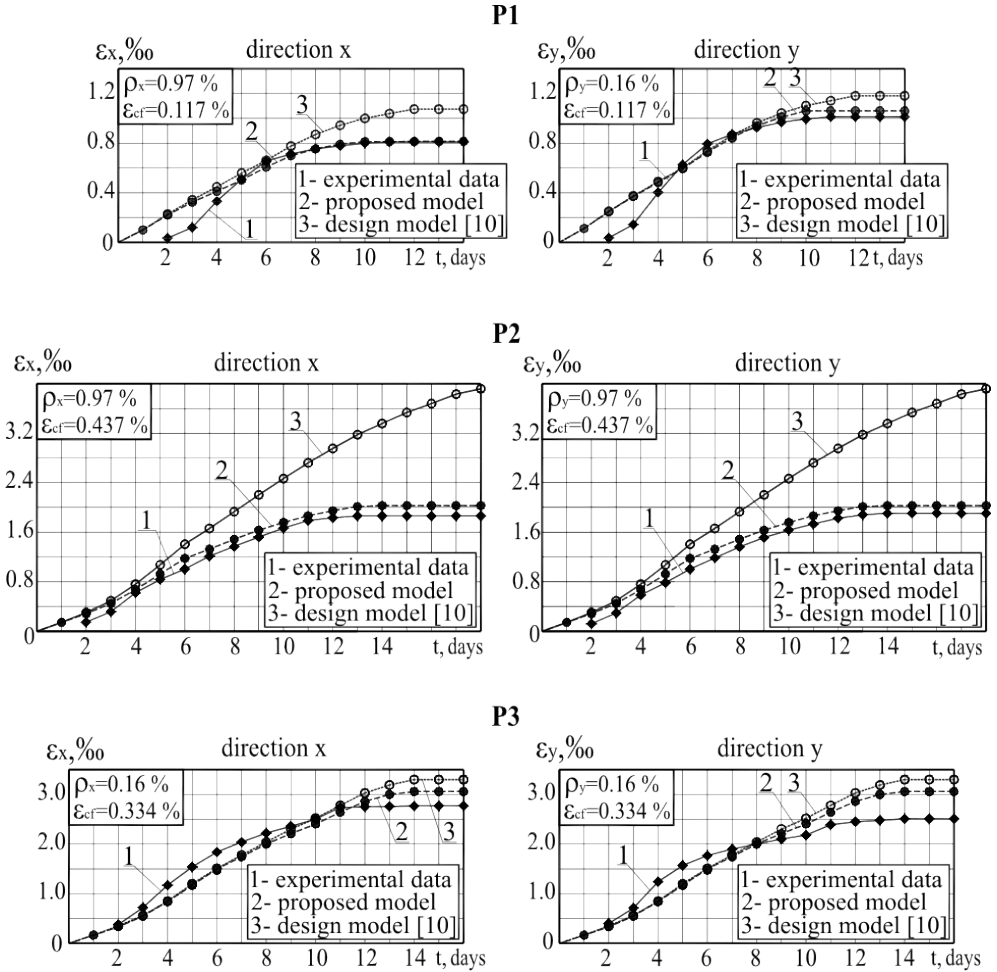

Fig. 2. Development of the restrained expansion strains for samples P1, P2 and P3. Source: own study

It is useful to demonstrate the comparison of experimental and calculated values of the restrained expansion strains at the end of the expansive concrete hydration period for all test samples (see Table 2). The calculated values of the restrained expansion strains were obtained based on the model 2D MSDM as well as based on the models [3], [5], [10]. Note that the models [3] and [5] are based on the chemical energy conservation law and allow defining the stress-strain parameters of the expansive concrete elements only by the end of expansion concrete stabilization period.

Table 2. Experimental and calculated values of the restrained expansion strains. *Source:* own study

Source	Specimen marking					
	P1		P2		P3	
	$\rho_{s,x} = 0.97\%$, $\rho_{s,y} = 0.16\%$		$\rho_{s,x} = 0.97\%$, $\rho_{s,y} = 0.97\%$		$\rho_{s,x} = 0.16\%$, $\rho_{s,y} = 0.16\%$	
Values of the restrained expansion strains (%) in the direction:						
	x	y	x	y	x	y
Experimental data	0.811	1.013	1.883	1.906	2.770	2.512
Calculated values, according to the model 2D MSDM	0.813	1.061	2.031	2.031	3.063	3.063
Calculated values, according to [3]	0.860	3.070	1.470	1.470	4.610	4.610
Calculated values, according to [5]	0.792	2.850	1.240	1.240	3.793	3.793
Calculated values, according to [10]	1.074	1.183	3.915	3.915	3.286	3.286

3.2. Expansive concrete-filled steel tubes

Experimental studies were carried out on the two series of expansive concrete-filled steel tubes (EC FST) with the diameter 200 mm, length 300 mm and 600 mm and steel tube wall thickness 1.0 mm, 1.5 mm and 2.0 mm. The variation of the following parameters is considered: effective restraint ratio $\rho_{1,0}$ and $\rho_{1,z}$; length of steel tube (300 mm and 600 mm); self-stressing grade of expansive concrete; influence of internal curing.

Development of restrained expansion strains in time under different restraint conditions in longitudinal and circumferential directions is shown in Fig. 3.

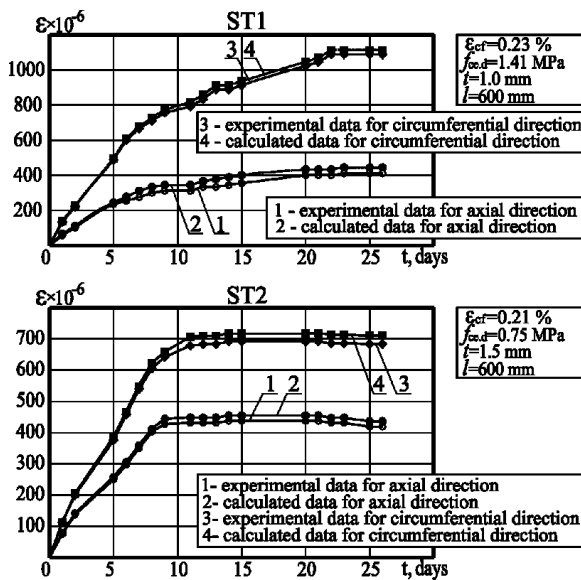

Fig. 3. Development of the restrained expansion strains tube samples. *Source:* own study

Restrained expansion strains obtained in the experimental campaign (see Fig. 3) were compared to those calculated following the proposed model for the expansive concrete-filled steel tubes. As follows from the comparison of the results, the restrained expansion strains value calculated in accordance with the proposed model shows a good agreement with experimental data.

4. Conclusions

The modified early age strains development model for the biaxial restraint conditions based on the initial early age strain calculation approaches is universal and allows obtaining an adequate solution for any boundary conditions.

The free expansion strains development law of the expansive concrete from the early age to the end of stabilization period is accepted as the basic parameter when defining the stress-strain parameters of expansive concrete elements under biaxial restraint conditions.

The suitability of the proposed model was confirmed by the own experimental investigations of expansive concrete elements under two-way restraint conditions as well as the experimental results of expansive concrete-filled steel tubes. The difference between the experimental and calculated values of the restrained expansion strains did not exceed 25.5%.

References

- [1] Mikhailov V. and Litver S., *Expansive and self-stressing cements and self-stressed reinforced structures*. Stroyizdat, Moscow, 1974, p. 312 (in Russian).
- [2] Mikhailov V. and Gershvald V., “Plane self-stressed structures”, in *Researches and usage of self-stressing concrete and self-stressed structures: NIIZHB*, 1984, pp. 62-67 (in Russian).
- [3] TCP 45-5.03-158-2009, concrete and reinforced concrete structures from self-stressing concrete: design rules, Minsk, 2010 (in Russian).
- [4] Ishikava Y., Shibata K. and Tanabe T., “Initial stress analysis of expansive material under restrictions based on chemical conservation law”, in *Creep, Shrinkage and Durability Mechanics of Concrete and Concrete Structures*, 2009, pp. 437-443.
- [5] Marchuk V., *Strains and stresses of plane self-stressing concrete elements under nonsymmetrical biaxial restraint at the expansion stage*, (PhD thesis), BSTU, Brest, Belarus, 2002 (in Russian).
- [6] Litver S. and Petukhov A., “Stresses under bi-axial restraint conditions”, in *Researches and usage of self-stressing concrete and self-stressed structures: NIIZHB*, 1984, pp. 67-78 (in Russian).
- [7] Man T., Wang B., Jin H. and Zhang X., “Expansion behavior of self-stressing concrete confined by glass-fiber composite meshes”, in *Construction and Building Materials*, no. 128, 2016, pp. 38-46. <https://doi.org/10.1016/j.conbuildmat.2016.10.022>
- [8] Okada K., Ohta M., Nagafuchi T., Yata A. and Tamai S., “Characteristics of expansive concrete under bi-axial restraint”, *Journal of the Society of Material Science*, no. 32, 1983, pp. 182-187.
- [9] Wang V., Han T. and Jin H., “Prediction of expansion behaviour of self-stressing concrete by artificial neural networks and fuzzy inference system”, *Construction and Building Materials*, no. 84, 2015, pp. 184-191. <https://doi.org/10.1016/j.conbuildmat.2015.03.059>
- [10] Ito H., Maruyama I., Tanimura M. and Sato R., “Early age deformation and resultant induced stress in expansive high strength concrete”, *Journal of Advanced Concrete Technology*, 2004, vol. 2, no. 2, pp. 155-174.
- [11] Semianiuk V., Tur V., Herrador M.F. and Paredes G.M., “Early age strain and self-stresses of expansive concrete members under uniaxial restraint conditions”, *Construction and Building Materials*, 2017, no. 131, pp. 39-49.
- [12] Lei H., Chengkui H. and Yi L., “Expansive performance of self-stressing and self-compacting concrete confined with steel tube”, *Journal of Wuhan University of Technology-Mater. Sci. Ed.*, 2007, pp. 341-345. <https://doi.org/10.1007/s11595-005-2341-2>