

THE EFFECT OF CLAY ADDITION ON THE SETTLING ABILITY OF ACTIVATED SLUDGE AS A PROPOSED METHOD TO CONTROL FILAMENTOUS BULKING

Miriam E. Wells

**A thesis submitted in partial fulfilment of the
requirements for the Degree of Master of Science in
Microbiology**

**University of Canterbury
2014**

TABLE OF CONTENTS

ACKNOWLEDGMENTS	i
ABSTRACT	ii
LIST OF FIGURES	iii
LIST OF TABLES	iv
ABBREVIATIONS.....	v
CHAPTER 1.0 INTRODUCTION	1
CHAPTER 2.0 LITERATURE REVIEW.....	2
2.1 Biological wastewater treatment and the activated sludge process (ASP)	2
2.2 Microbiological operating issues with the ASP	4
2.2.1 Filamentous bulking and the problems it causes	4
2.2.2 Theories into causes of filamentous bulking	6
2.2.2.1 Kinetic Selection Theory	6
2.2.2.2 Storage Selection Theory	7
2.2.2.3 Diffusion Based Selection Theory.....	8
2.2.3 Flow on effects of filamentous bulking	9
2.3 Research into filamentous bulking	10
2.4 Sludge Volume Index	10

2.5	Preventative methods.....	11
2.5.1	Microbiological investigation.....	11
2.5.1.1	Traditional microscopic techniques.....	11
2.5.1.2	Optical monitoring, image analysis and genetic probes	12
2.6	Controlling methods	14
2.6.1	Chlorination.....	14
2.6.2	Bacteriophages.....	15
2.6.3	Selectors	16
2.6.4	Other control methods.....	17
2.7	Why activated sludge bulking needs further investigation.....	18
CHAPTER 3.0 OBJECTIVES.....		19
CHAPTER 4.0 MATERIALS AND METHODS.....		20
4.1	Set-up and operating conditions.....	20
4.1.1	Biomass and SWW	20
4.1.2	SBR system configuration and operation.....	22
4.1.3	Function of each reactor run.....	25
4.2	Analytical methods.....	26
4.2.1	SWW analysis.....	26
4.2.1.1	pH of the SWW	26
4.2.1.2	COD of the SWW.....	26
4.2.2	SBR analytical methods	27
4.2.2.1	pH in the SBRs	27
4.2.2.2	COD in the SBRs.....	27
4.2.2.3	DO	27
4.2.2.4	TSS and VSS.....	27

4.2.2.5	SVI.....	29
4.3	Microbiological parameters	30
4.3.1	Calculation of filament length	30
4.3.2	Authentication of preservation method	32
4.3.3	The relationship of SVI to abundance of filamentous bacteria	32
4.4	Clay settling batch tests	32
4.4.1	Clay batch test system configuration and operation	33
4.4.2	Batch test analytical methods	36
4.4.2.1	pH.....	36
4.4.2.2	COD sampling stages	36
4.4.2.3	TSS and VSS.....	37
4.4.2.4	Modified SVI	37
4.4.2.5	Microbiological assessment	37
4.5	SBR clay tests	38
CHAPTER 5.0 RESULTS AND DISCUSSION.....		40
5.1	General observations and parameters	40
5.2	SWW characteristics.....	40
5.2.1	Use of different strengths of wastewaters	40
5.2.2	pH of the SWWs	41
5.2.3	COD of the SWWs.....	41
5.3	General SBR trends and parameters	42
5.3.1	pH of SBRs.....	43
5.3.2	COD in the SBRs	43
5.3.3	DO.....	45
5.3.4	SVI trends.....	46

5.3.5	VSS and TSS vs. SVI.....	49
5.4	Microbiological data with SBRs	50
5.4.1	Authentication of the microbiological preservation method	50
5.4.2	SVI Related to Filamentous Bacteria Abundance	51
5.5	Clay settling batch tests	52
5.5.1	Preliminary clay batch tests.....	53
5.5.2	Secondary clay settling batch tests	54
5.5.2.1	pH and COD of batch test	55
5.5.2.2	Microbiology and settling in the clay batch test	55
5.5.3	Discussion of batch test results.....	58
5.6	Clay tests in the SBRs.....	60
 CHAPTER 6.0 CONCLUSIONS AND RECOMMENDATIONS		64
 CHAPTER 7.0 REFERENCES		67

ACKNOWLEDGMENTS

I would like to express my thanks to my supervisors, David Wareham and Paul Broady for their support in the execution of this thesis. I am grateful for their encouragement, their direction, their many useful comments, their expert advice and their constructive criticism. I am also indebted to Peter McGuigan and David MacPherson for their technical expertise, their advice and their assistance. Finally, I would like to thank my family who have encouraged me to see this thesis through to completion.

ABSTRACT

Filamentous bulking is a problem that has long plagued activated sludge (AS) wastewater treatment plants (WWTPs). Much research has looked at its prevention and control but there is still no solution. The sludge microbiological community is very complex and there are many factors that can affect bulking. Clay addition in scaled-down activated sludge systems was investigated at concentrations of 0.4, 2.0 and 5.0 g/L along with sequencing batch reactor (SBR) parameters when run with a synthetic wastewater (SWW). The 5.0g/L concentration exhibited positive results on settling in the form of modified SVI but appeared to cause no reduction in filament length. These preliminary investigations indicate that clay may help improve sludge settling but make no difference in the abundance of filamentous microorganisms.

The SBRs exhibited trends in regards to running systems with a synthetic wastewater. A loss of volatile suspended solids (VSS), coupled with increase in sludge volume index (SVI), suggested a link between lack of non-VSS and settling ability. This has implications in the importance of non-VSS such as grit or clay in research performed using SWWs.

LIST OF FIGURES

Chapter 2

Figure 2.1	Flow diagram of the WWTP processes of primary, secondary and tertiary treatment.....	3
-------------------	--	----------

Chapter 4

Figure 4.1	Sequencing batch reactor set up up.....	23
-------------------	---	-----------

Chapter 5

Figure 5.1	COD over time (5 hours) with glucose-normal strength feed on SBRs 1&2.....	44
Figure 5.2	COD over time (6 hours) with glucose-double strength feed on SBRs 1&2.....	45
Figure 5.3	COD over time (5 hours) with sucrose-double strength feed on SBRs 1&2.....	45
Figure 5.4	DO profile across two mixing cycles (412 minutes each).....	46
Figure 5.5	SVI and VSS on a preliminary run of SBR 1 (Run 1.1).....	47
Figure 5.6	SVI and VSS on a preliminary run of SBR 2 (Run 2.2).....	47
Figure 5.7	SVI and ratio of VSS: TSS on a preliminary run of SBR 1.....	50
Figure 5.8	SVI and ratio of VSS: TSS on a preliminary run of SBR 2.....	50
Figure 5.9	Relationship between filament length (m/mL) and SVI over time in SBR 1.....	52
Figure 5.10	Relationship between filament length (m/mL) and SVI over time in SBR 2.....	52
Figure 5.11	Settling volumes of different clay concentrations after 30 minutes..	53
Figure 5.12	Effect of different concentrations of clay suspension on sludge over 5 days expressed in the form of modified SVI.....	54
Figure 5.13	Relationship between filament length (m/mL) and SVI on the SBR run before being used for batch tests.....	56
Figure 5.14	TSS, VSS and SVI on the SBR before the clay was sourced on day 18 for batch test.....	56
Figure 5.15	SVI over the 5 day batch test with blank and clay (5.0 g/L) treatments.....	57
Figure 5.16	TSS, VSS and SVI over time on SBR 1, no clay added.....	61
Figure 5.17	TSS, VSS and SVI over time on SBR 2, clay added.....	62
Figure 5.18	SVI and filament length over time. SBR 1, no clay added.....	62
Figure 5.19	SVI and filament length over time. SBR 2, clay added.....	63

LIST OF TABLES

Chapter 4

Table 4.1	Synthetic wastewater chemicals.....	21
Table 4.2	Duration and feed of each run.....	21
Table 4.3	Reactor runs with their associated functions.....	25
Table 4.4	Primary and secondary clay batch tests.....	35

Chapter 5

Table 5.1	Mean pH of different synthetic wastewaters used.....	41
Table 5.2	Average COD of different synthetic wastewaters used.....	41
Table 5.3	COD (mg/L) of the different strengths of wastewaters over time....	42
Table 5.4	Changes in COD (mg/L) over 5 hours with glucose-normal strength feed	44
Table 5.5	Sample size, mean and standard deviation of total length of filamentous micro-organism (m/mL) in samples treated with Lugol's Iodine solution at 1 and 14 days.....	51
Table 5.6	COD (mg/L) on day 1 of the batch tests in each treatment at 0.25 hours, before feeding with SWW, after feeding with SWW and at 5.5 hours in the mixing cycle.....	55
Table 5.7	COD (mg/L) on day 5 of the batch tests in each treatment at 0.25 hours, before feeding with SWW, after feeding with SWW and at 5.5 hours in the mixing cycle.....	55
Table 5.8	Ratio of VSS:TSS in blank and clay treatments over the 5 day batch test.....	57
Table 5.9	Average filament length (m/mL) on each of the three replicates in each treatment on day 1, 3 and 5.....	58

ABBREVIATIONS

AS	Activated sludge
ASP	Activated sludge process
COD	Chemical oxygen demand
DO	Dissolved Oxygen
FISH	Fluorescent in situ hybridization
K_s	Kinetic half saturation constant
KST	Kinetic selection theory
LFB	Limited filamentous bulking
μ_{max}	maximum growth rates
PP	Pin point
SBR	Sequencing batch reactor
SSVI	Stirred sludge volume index
SVI	Sludge volume index
SWW	Synthetic wastewater
TSS	Total suspended solids
VSS	Volatile suspended solids
WWTP	Wastewater treatment plant

1.0 INTRODUCTION

The efficient treatment of wastewater is an important research area in light of water reuse, increasing global population size and the resultant increasing demand for clean water (Gupta *et al.* 2012, Wei *et al.* 2012, Varela and Manaia 2013). Ever diminishing freshwater resources, the need to protect existing resources from pollution and the imminent issue of water reuse along with the microbiological effect on human health, plays an important role in researching new ways to increase the quality of water being released back into the environment.

The operation of an efficiently functioning wastewater treatment system is essential to the health and well-being of any centre of human population. The activated sludge process (ASP) is widely used in the treatment of wastewater and when functioning efficiently it is effective. However, ASP wastewater treatment plants do not always function without problems. One of the main problems faced is filamentous bulking (Novak *et al.* 1993) and this is the focus of the present research.

2.0 LITERATURE REVIEW

2.1 Biological wastewater treatment and the ASP

Wastewater treatment has an overall objective to remove the organic matter and nutrients from the incoming wastewater, so that ultimately water of a suitable quality can be discharged back into the environment. This is coupled with a developing and more recent focus on increasingly thorough decontamination from pathogens depending on the waters intended use (Gupta *et al.* 2012, Varela and Manaia 2013). Treatment can be carried out in three main treatment stages; primary, secondary and tertiary (see Figure 2.1). Primary treatment involves the most basic treatment where screening of the wastewater occurs through the use of screens, grit traps, and physical settling, resulting in the reduction and removal of some grit and the largest solids such as pieces of paper, wood and cloths etc. (Gupta *et al.* 2012). Secondary wastewater treatment is where biological treatment of wastewater actively occurs. The solids are further separated out through physical settling and microbial action. Tertiary treatment follows, usually in order to prepare for human consumption. This is achieved through processes such as distillation, ozonation and solvent extraction (Gupta *et al.* 2012).

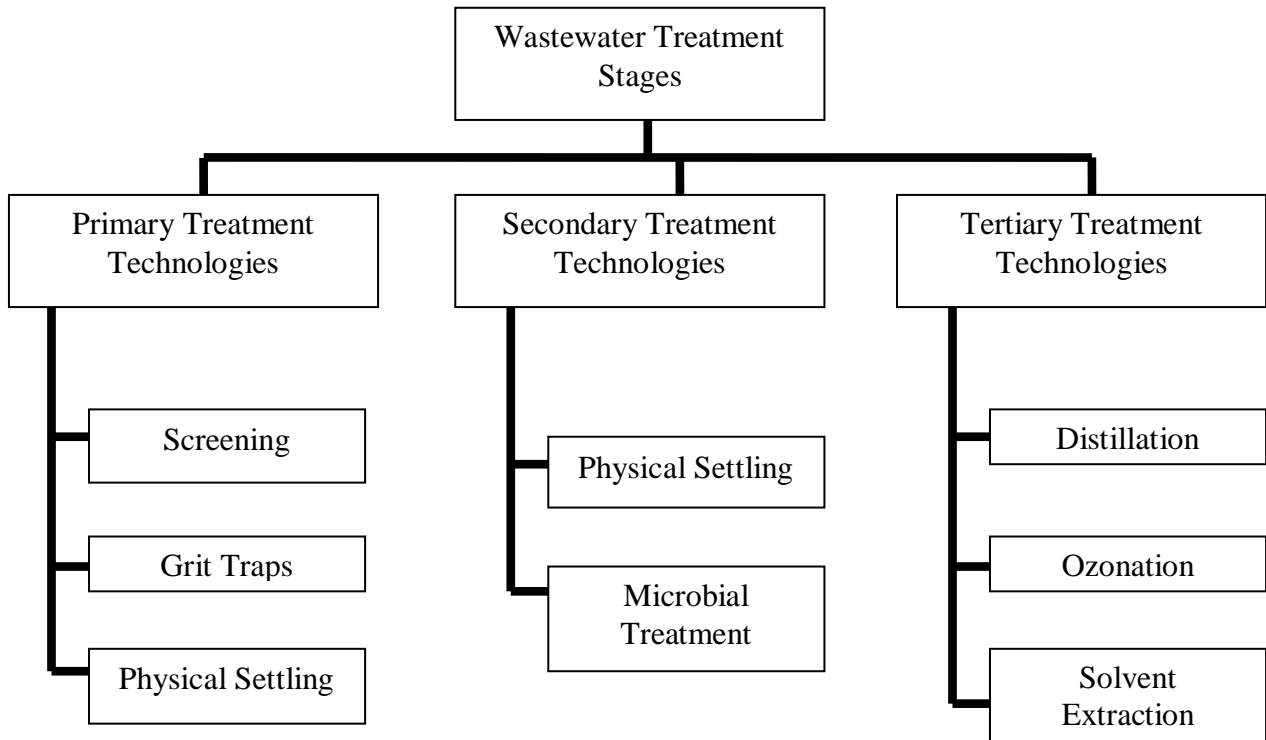

Figure 2.1: Flow diagram of the WWTP processes of primary, secondary and tertiary treatment.

In industrialized countries, the ASP is the most common form of technology used for biological wastewater treatment (Martins *et al.* 2004, Smets *et al.* 2006, Schuler and Jassby 2007), taking place in the secondary treatment stage. Activated sludge (AS), is a complex and diverse microbiological mixture comprised of a variety of bacteria, viruses, fungi, metozoa, protozoa and algae (Hu *et al.* 2013). When maintained under the correct conditions, floc-forming bacteria provide an efficient way of removing both the nutrients and organic matter from the incoming wastewater (Martins *et al.* 2004).

Firstly, the removal of the organic matter is achieved during the mixing and aeration of the wastewater with the AS due to its consumption by floc-forming bacteria (Madoni *et al.* 2004) and secondly, by settling of the biomass using a physical solid-liquid separation process

(Smets *et al.* 2006). In an efficiently operating AS WWTP, a good quality effluent can be produced (Martins *et al.* 2004) and subsequently released into the environment. However, AS plants often face sub-optimal efficiency at some stage in their operation.

2.2 Microbiological operating issues in the ASP

Activated sludge is sensitive to both environmental and operational pressures (Mesquita *et al.* 2011) and multiple factors have been shown to contribute to changes in the sludge community structure (Hu *et al.* 2013). These shifts sometimes cause floc settling problems. Some common microbiological and settling issues include pinpoint (PP) floc formation, viscous or zoogeal bulking and filamentous bulking (Mesquita *et al.* 2011). PP floc formation is characterized by very-small, pinpoint-like, fragile flocs which create a poor settling sludge (Jenkins *et al.* 2003). Viscous or zoogeal bulking leads to an excess of extracellular polysaccharides produced by the microorganisms. This prevents close packing of flocs and causes poor settling (Novak *et al.* 1993, Jenkins *et al.* 2003). Filamentous bulking is one of the most commonly occurring and widely studied issues in biological wastewater treatment. It is caused by an excessive growth of filamentous bacteria (Ziegler *et al.* 1990, reviewed by Martins *et al.* 2004, Nielsen *et al.* 2009), and is an issue which has long plagued WWTPs.

2.2.1 Filamentous bulking and the problems it causes

Filamentous bacteria in AS are beneficial to sludge health in reasonable quantities, helping provide the backbone for healthy floc formation (Jenkins 2003, Mesquita *et al.* 2011). There is also some evidence that under certain conditions, limited filamentous bulking (LFB) can enhance nutrient removal efficiency, an important aspect of modern wastewater treatment (Tian *et al.* 2011, Guo *et al.* 2012b, Yang *et al.* 2013). Tian *et al.* (2011) observed that a LFB state (SVI value of 170-200 mL/g) created under low dissolved oxygen (DO) conditions (1.0-

1.5 mg/L), resulted in a high percentage of nutrient removal that reduced chemical oxygen demand (COD), TP and $\text{NH}_4^+\text{-N}$ by 90%, 97% and 92% respectively. The settling achieved under the LFB state also produced a very good quality effluent with no sludge loss noted. Limited amounts of filamentous bacteria may be beneficial to sludge settleability and reactor performance (Tian *et al.* (2011), Yang *et al.* (2013)). However, the unrestrained growth of filaments is detrimental to this. Excessive growth inhibits the sinking of floc-forming bacteria by preventing close packing of the flocs (Schuler and Jassby *et al.* 2007), making the flocs longer and more fragile (Koivuranta *et al.* 2013), decreasing the thickening of the settled sludge.

Despite much research into filamentous bulking, neither a general cause nor a method for control has been identified (Martins *et al.* 2004). Filamentous bulking has been related to the morphology of the filamentous bacteria as a whole without focusing on particular species (Chudoba *et al.* 1973, Martins *et al.* 2004). For example Chudoba *et al.* (1973), investigated the control of filamentous microorganisms collectively by use of a selector (Section 2.6.4), which created conditions to suppress filament growth. Another way filamentous bulking has commonly been addressed is by determining the dominant filament types present in a bulking sample through microscopic examination and identification keys (see Section 2.5.1) (Eikelboom *et al.* 1977, Jenkins *et al.* 1984). The aim has been to find a way to prevent the responsible type(s) of filament from occurring in over-abundance (Martins *et al.* 2004).

Many different morphotypes of filamentous bacteria have been identified as causative species in sludge bulking (Wagner and Loy 2002) with some of the common species being from the genera *Nostocodia*, *Thiothrix* and *Microthrix* (Nielsen *et al.* 2009). Research has focused on identification of the morphotype(s) of bacteria responsible for bulking episodes while trying

to link them to particular causes. Some of the conditions linked to bulking include; temperature (Hu *et al.* 2013), low DO concentrations (Martins *et al.* 2003, Wang *et al.* 2010), readily degradable substrates and nutrient deficiency (reviewed by Martins *et al.* 2004, summarised by Richard 2003), sludge loading, and feeding pattern of the sludge. The type of wastewater can also have an influence on sludge bulking. In synthetic wastewater trials, both high and low nutrient wastewaters have been shown to be a help cause filamentous bulking (Gulez and de los Reyes III 2009 and Wang *et al.* 2010). Multiple factors can work together to cause filamentous bulking, for example Martins *et al.* (2003) found that a low DO concentration combined with a high COD loading rate accentuated poor settling issues. In summary, filamentous bulking is a widely studied and complex topic, with no one clear cause and effect.

2.2.2 Theories into causes of filamentous bulking

The following section briefly outlines three theories; namely the Kinetic Selection Theory, the Storage Selection Theory and the Diffusion-Based Selection Theory (reviewed by Martins *et al.* 2004), which suggest why microbially induced filamentous bulking may occur.

2.2.2.1 Kinetic Selection Theory

Kinetic Selection Theory (KST) is probably the most widely used theory to explain the relationship between filamentous and non-filamentous bacteria and filamentous bulking (Lou and de lou Reyes III 2005). It was first formulated by Chudoba *et al.* (1973) and is based on the Monod equation. It postulates that filamentous and floc forming bacteria have, on average, different kinetic constants K_s (half saturation constants) and maximum growth rates (μ_{max}) under soluble substrate concentrations. Because of this they are expected to have different growth rates and should perform differently under different substrate concentrations.

It is this difference in growth rate that is thought to give the filamentous bacteria an advantage over floc-forming bacteria under certain conditions. Floc formers are thought to have higher μ_{\max} and K_s values than their filamentous counterparts. In higher substrate concentrations the growth rate of filamentous bacteria is expected to be less favoured than floc-formers (Chudoba *et al.* 1973, Chudoba *et al.* 1985). The opposite should then apply in systems at low substrate concentrations, in which filamentous bacteria (thought to have a lower K_s than floc formers) should gain a competitive advantage due to a higher growth rates and out-compete the floc-forming bacteria.

Even though there is evidence to support the KST in the form of experimental trials (Van den Eyne 1983, Chudoba *et al.* 1985), it is still not proven to be the explanation behind the microbiological cause of bulking. There is also currently no theory to explain why the filamentous bacterial morphology would result in them having a slower growth rate in general than the non-filamentous morphologies (Martins *et al.* 2004). Another potential problem with this theory (Martins *et al.* 2004) is the floc-forming bacteria on which the KST is based may not be representative of the floc-forming species that are representative of and important in activated sludge. With recent advances in genetic probes (see Section 2.5.2), investigation into activated sludge community structure suggests that there are more species present than originally realised and that these play important roles in community structure (Wagner *et al.* 1993, Wagner *et al.* 2002). This in turn has led to the realisation that there are more factors operating in KST than originally suggested by Chudoba *et al.* (1985).

2.2.2.2 Storage Selection Theory

The Storage Selection Theory is based on the hypothesis that typically filamentous and non-filamentous bacteria have different storage abilities which will give them advantages under

different conditions. Substrate storage happens when substrate is transported inside the cell but not fully utilized and instead is stored for later use.

Non-filamentous microorganisms are thought to have the ability to store substrate when it is available at high concentrations (Martins *et al.* 2004). However, some studies have shown that this may not be the case and that some filamentous bacteria like *M. parvicella*, which is a major cause of bulking, can also have equally as high, if not higher storage capacities than non-filaments under a range of environmental conditions (Andreasen and Nielsen 2000).

Due to the constantly changing environment that is in a WWTP with both dynamic influent characteristics and fluctuating temperatures, sludge microorganisms must be able to cope with this environment. Therefore, naturally the microbes which are best suited to take advantage of and thrive in these conditions will out-compete others and will be selected.

This ability to store substrate under varying conditions would give these filamentous bacteria a competitive advantage over bacteria lacking this ability. If this theory is an explanation for bulking then the bacteria which can store substrate will be able to use it during periods of famine. Under the right conditions, this advantage could easily lead to an overgrowth of filaments, thus out-competing the floc-formers and resulting in bulking.

2.2.2.3 Diffusion Based Selection Theory

The Diffusion Based Selection Theory is summarised by Martins *et al.* (2004). The basis of this theory is that filamentous bacteria have a higher surface area to volume ratio than non-filamentous bacteria (Pipes 1967 in Martins *et al.* 2004) due to their morphology and therefore can absorb nutrients more readily than floc formers. Under low nutrient conditions

this structural difference appears to be particularly advantageous, leading to higher growth rates at low substrate concentrations (Martins *et al.* 2004).

Later expansions to this theory included the ability of filaments to easily extend out of the flocs, allowing them, especially in low substrate conditions to access more substrate than the floc formers situated inside the flocs (Sezgin *et al.* 1978). This creates potential to alter the structure of the flocs, causing them to become more open and filamentous (Martins *et al.* 2004), contributing to filamentous bulking and settling issues.

2.2.3 Flow on effects of filamentous bulking

Ultimately, it is believed that under certain conditions, filamentous bacteria gain a competitive advantage over floc forming bacteria for a variety of morphological and physiological reasons, causing excessive filament growth and altering the AS biomass makeup (Martins *et al.* 2004). The theories discussed in (Sections 2.2.2.1–2.2.2.3) are all based on the morphology and subsequent abilities of the filamentous bacteria to gain an advantage over floc-forming population.

Depending on the extent of the bulking problem, when it comes to releasing the treated wastewater into the receiving water, a high proportion of biological solids may be lost over the effluent weir. However, depending on each individual WWTP design and the level of sludge in the final clarifier before the effluent exits, a bulking sludge may or may not cause a problem in all WWTPs (Richard 2003). When solids are lost over the effluent weir, it is counter intuitive to the philosophy of wastewater treatment which aims to separate solids from liquids. Solids lost over the weir (unintentional wasting) causes problems by increasing

the suspended solids and biochemical oxygen demand of the receiving water, thus polluting it.

Excess nutrients released into the environment also can be responsible for eutrophication and algal blooms in freshwater bodies, for example excess phosphorus released into the environment from WWTPs, as reported in Strakova *et al.* (2013). Additionally, secondary treated wastewater released into the environment can have negative effects on freshwater ecosystems (Englert *et al.* 2013). As well as having a negative environmental affect, unintentional wasting as a result of sludge bulking may also incur a financial penalty to the wastewater treatment plant operator if they have exceeded the permitted effluent levels normally associated with their resource consent.

2.3 Research into filamentous bulking

It is clear that filamentous bulking causes problems in a variety of ways; thus for many years there has been extensive research from both the engineering and science (microbiological) perspectives into filamentous bulking (Lau *et al.* 1984, Martins *et al.* 2004, Martins *et al.* 2011). Despite much research, there is currently no one specific fail-safe method to prevent it due to the complexity of the biological process. Research however has been done into both preventing filamentous bulking from occurring as well as controlling it once it has occurred.

2.4 Sludge Volume Index

The sludge volume, index was originally developed as a daily tool to roughly measure and monitor the physical characteristics of activated sludge in WWTPs (Dick and Vesilind 1969). It has the advantages of being a simple, readily-available measurement and is indicative of whether a sludge is bulking (independent of the organism(s) responsible (Smets *et al.* 2006). Since its development in the 1930s (Mohlman 1934), it has been widely used to measure and

monitor bulking sludge in WWTPs around the world. The SVI value can be defined as the volume occupied by 1 g of activated sludge after settling for 30 minutes. Bulking sludge is defined as one that compacts and settles slowly (Richard 2003) with an SVI value normally greater than about 150 (Clark *et al.* 1977).

Studies have linked an increase in filament abundance with an increase in SVI (Amaral and Ferreira 2005, Hu *et al.* 2013, Jassby *et al.* 2014). SVI has also been positively correlated other properties of sludge such as sludge viscosity and amount of extracellular polymeric substances (Jin *et al.* 2003). Combined with microscopic investigation, the SVI measurement is a good tool for reflecting the settling characteristics of a sludge.

2.5 Preventative methods

Prevention of filamentous bulking is better than attempting to control it once it has happened and different techniques have been used to try and prevent filamentous bulking. These techniques range from WWTP design improvements (through the use of selectors) to optical monitoring of sludge populations for any changes in community structure as possible indicators of filamentous bulking.

2.5.1 Microbiological Investigation

Microbiological investigation into filamentous bulking aims to connect the environmental and operational conditions to the state of the microbial community in the sludge.

2.5.1.1 Traditional Microscopic techniques

Until genetic probes came into use in the 1990s (Martins *et al.* 2004), traditional microscopy was the primarily tool (coupled with identification manuals put out by Eikleboom (1977) and

Jenkins (1984)) to try and identify the microbes responsible for filamentous bulking through morphology alone (Wagner *et al.* 2002). Traditional microscopic techniques can be very time consuming and tedious with the outcome dependent on the interpretive ability of the individual. Another issue when it comes to identifying a particular species present in a sludge sample based purely on its morphology is that only a few filamentous bacteria responsible for bulking can be accurately identified in this way. A review by Nielsen *et al.* (2009) reports that only *M. parvicella* and *Mycolota* (or *Nocardia*) can be reliably identified through their morphology (Soddell and Seviour 1990). These are only a small representation of the potential AS biomass make-up and causative microbes of bulking. These factors collectively decrease the accuracy of being able to successfully identify species responsible for bulking through traditional microscopy alone.

2.5.1.2 Optical monitoring, image analysis and genetic probes

Optical monitoring through image analysis is a computer-assisted process analysing digital images taken from microscopic investigation (Smets *et al.* 2006) and is rapidly replacing traditional microscopic methods (Costa *et al.* 2013). This increases the speed and accuracy of monitoring bulking episodes as well as visualisation of the structure of floc and sludge, and has significant advantages over traditional microscopy.

Recent studies have used optical monitoring techniques for a variety of uses including investigation into floc characteristics (Wilen and Lant 2003), AS settling ability (Mesquita *et al.* 2009), monitoring (Jenné *et al.* 2007), visualisation of AS under different malfunctioning conditions of PP floc formation, viscous bulking and filamentous bulking (Amaral and Ferreira 2005, Mesquitia *et al.* 2011, Amaral *et al.* 2013), and the relationship between floc morphology to effluent characteristics (Koivuranta *et al.* 2014). These all provide valuable

insight into AS community structure and behaviour when experiencing settling issues. Another focus of the above research which has been made more feasible with these tools is using it to discover potential bulking indicators through the development of mathematical models (Smets *et al.* 2006, Mesquita *et al.* 2009).

Genetic probes such as fluorescent in situ hybridization (FISH) are useful culture-independent species identification tools. The development of these has greatly increased knowledge of activated sludge populations by helping with species identification (Nielsen *et al.* 2009). FISH is able to visibly detect the presence of a particular organism, through the use of a fluorescent marker/probe. Probes can be a section of rRNA oligonucleotides specific to a particular organism attached to a fluorescent tag. If the organism is present in a sample, this will bind to the complementary section of rRNA, and indicates its presence when fluorescence is stimulated by UV light.

A combination of image analysis (and sometimes traditional light microscopy and confocal laser microscopy) has also been combined with the use of genetic probes for filament identification and insight into AS sludge structure (Wagner and Loy 2002, Schmid *et al.* 2003, Wilen *et al.* 2008, Yang *et al.* 2013). For example Yang *et al.* (2013) used a combination of identification handbooks, image analysis and FISH to monitor flocs under a LFB state while investigating nutrient removal performance.

The benefits of using FISH to identify species present in sludge samples, compared to traditional microscopic identification methods, is that it is genetically accurate and not subjective. However, a problem with FISH is that the markers have to be specific for each species and for some species markers have yet to be developed. For example Nielsen *et al.*

(2009) reports that there is no probe for types 0914 and 0803 as there is not a rRNA sequence data available for the specific probe design. Despite this disadvantage, genetic probes (along with image analysis) provide useful tools in the investigation of AS bulking and they have potential to detect changes in community structure which are not necessarily observable through SVI values and traditional microscopy alone. Therefore they can help with predicting bulking episodes. For example, Da Motta *et al.* (2002) used image analysis to detect bulking episodes. Predicting when bulking events will occur means there is more time to take appropriate remedial actions, potentially reducing cost of treatment.

2.6 Controlling methods

Although prevention is always the best cure, bulking is not always preventable, and such there are multiple methods employed to try and control bulking once it has happened.

2.6.1 Chlorination

The most common non-specific method for controlling filamentous bulking is through chlorination (Caravelli *et al.* 2003, Caravelli *et al.* 2006). Adding chlorine to bulking sludge in the right concentration specific to each bulking episode should result in the chlorine killing off the exposed outer filaments while mostly sparing the floc-forming bacteria (Richard 2003). The principle behind this is that the chlorine should affect the filaments more than the floc-formers as the filaments often branch out of the flocs during a bulking episode (Koivuranta *et al.* 2013). As such, the flocs are more protected meaning the filaments will be more affected by the chlorine due to their exposure.

Chlorine is a relatively cheap and easy way of responding to a bulking problem; however treating with chlorine does not solve the original cause of the bulking. That is, even though

chlorine addition during bulking should theoretically harm the filaments more than the floc-formers, it is still non-selective and therefore will also be harmful to floc-forming bacteria (Van Leeuwen 1992, inside Caravelli *et al.* 2006). In a pure culture study comparing the susceptibility of one typically-occurring filamentous bacteria *Sphaerotilus natans* with one typically-occurring floc former *Acinetobacter anitratus*, Caravelli *et al.* (2003) found the floc-forming species was more susceptible to chlorine than the filamentous species. However, some filamentous bacteria have been shown to be resistant to chlorine; for example, Guo *et al.* (2012a) encountered a chlorine resistant Type 021N filament which when chlorine was added as a control method for bulking was unaffected with the bacteria Type 021N maintaining cell integrity at a chlorine dose of up to 80 mg Cl/SS.

Another negative effect of chlorine addition is that it has the potential to form compounds which can harm human health such as carcinogenic halogenated organic carbons. However the formation of these compounds is unlikely in the doses generally used and the short time frame the chlorine stays present in the sludge (Richard 2003). Because chlorine is not a preventative measure and controls bulking after it has occurred, it is possible that bulking problems may respond positively to chlorine addition for a time and then reoccur more severely than before chlorine was added the first time.

2.6.2 Bacteriophages

A previously unexplored technology for the control of filamentous bulking is the use of lytic bacteriophages (Kotay *et al.* 2010). These are viruses which specifically infect bacteria resulting in lysis of the infected cell. Due to the fact that each type of bacteriophages is selective and only infects certain bacteria (Henry and Debarbieux 2012), they are a safe control method as they will not pose a threat to other organisms. Kotay *et al.* (2010) isolated

a bacteriophage specific to the filament *Haliscomenobacter hydrossis*, which was chosen as a representative filamentous species for bulking. The results were promising, showing a reduction in the SVI value from 150 to 105 mL/g (i.e. improved settling (see Section 2.4)). This new method shows promise for controlling specific filaments responsible for bulking and is a potential future avenue for research.

2.6.3 Selectors

The use of a selector to control filamentous bulking is a preventative measure as opposed to chlorination (Section 2.6.1) which is an after-the-fact control measure. The purpose of selectors is to try and create an environment which suppresses the overgrowth of filamentous bacteria while keeping a balance between the filamentous bacteria and floc forming bacteria. A selector, according to Chudoba *et al.* (1973), can be described as the initial part of the aeration system in a biological reactor, where a substantial substrate concentration gradient occurs. In selectors, the sludge is subject to periods with different concentrations of substrate (food); thereby subjecting the organisms to a ‘feast’ environment for a period, with high growth rates and conditions that allow for the microbes to store substrate. This period is then followed by a low growth rate ‘famine’ environment with less available substrate to consume, which should in turn re-establish the cells storage capacity. These conditions are thought to favour non-filamentous bacteria and as such should discourage filamentous overgrowth (Van den Eynde *et al.* 1983, Chiesa *et al.* 1984, Martins *et al.* 2004, Ferreria *et al.* 2014). However, much of the research on which substrate concentration conditions encourage the growth of non-filamentous bacteria over filaments are carried out in pure culture experiments (Van den Eynde *et al.* 1983, Chiesa *et al.* 1984) which may not necessarily represent the behaviour in full-scale plants.

There are multiple types of selectors used to control bulking; namely aerobic, anaerobic and anoxic selectors. For example, aerobic selectors were developed in response to many activated sludge plants being equipped for biological nitrification, which resulted in improved aeration systems to keep the nitrifying bacteria in the system. This led to conditions of bulking sludge (Martins *et al.* 2004) and although aerobic selectors have been shown to control filamentous bulking in some instances (Ferreria *et al.* 2014), there are still some questions about the effectiveness of selectors and whether other factors may be involved when the selector does not prevent bulking (Martins *et al.* 2004, Gray *et al.* 2010).

2.6.4 Other control methods

Other bulking control methods include hydrogen peroxide and ozone addition, which are not as widely used or effective as chlorine addition (Saayman *et al.* 1998). Chemical flocculating agents addition (ferrous sulphate and aluminium chloride) have also been used as to help with the settling properties of activated sludge (Agridiotis *et al.* 2007, Park *et al.* 2010). Agridiotis *et al.* (2007) observed an improvement in SSVI (stirred SVI) in the treatment of a paper mill wastewater in lab scale tests with ferrous sulphate and aluminium chloride which reduced the SSVI value from an initial value exceeding 300 down to 90 after 3 weeks of treatment.

Other agents added to pilot plant activated sludge and SBR systems include chlorite and calcium carbonate to help with settling (Piirtola *et al.* 1999a & Piirtola *et al.* 1999b). In a study by Eikleboom and Grovenstein (1988), a very severe bulking problem caused by the overgrowth of Type 021N experienced in a full scale plant was alleviated by the addition of talc (PE 8418). It was reported that after addition of the talc the SVI dropped from 850 mL/g to 100-125 mL/g over two weeks.

2.7 Why activated sludge bulking needs further investigation

Despite extensive research into the problem of filamentous bulking there is still no definitive answer as how to best to prevent and treat it. The activated sludge process is a complex process with many factors (ranging from WWTP design and the incorporation of selectors to environmental conditions and effluent characteristics) that affect overall sludge community structure and the occurrence of filamentous bulking. Since there is no simple cure, filamentous bulking is still a topic worthy of investigation particularly novel control method/remedial action.

Recently some unpublished preliminary tests have shown that the addition of clay may improve the settling of sludge in systems with excessive filamentous growth. These preliminary results may fit in with the findings of Eikleboom and Grovenstein (1988) where talc addition was used to control bulking. The reasons why clay may improve settling are unknown but it has been speculated that the addition of clay may somehow improve sludge settleability by acting as a starting point for an aggregate of floc forming bacteria to form around thereby inducing sinking. Another possibility is that the settling may only appear improved (with improvement detectable through the SVI measure), because the clay may be simply weighing-down the sludge by the clay particles. The exact mechanism is not known however warrants further investigation in the form of the following research.

3.0 OBJECTIVES

As mentioned, some preliminary unpublished investigations have shown that clay may be a possible remediation measure to control filamentous bulking in activated sludge systems. The aim of this research is to: (i) investigate whether the addition of clay is a feasible method for the control of filamentous bulking bacteria and (ii) shed light on the microbiological effect of clay on filamentous bacteria. In order to do this the following aspects were assessed experimentally, split into the sections shown below:

- i) Phase I: General running of SBRs in relation to characterising settling and microbiological parameters.
- ii) Phase II: Bench-scale clay test examining settling and microbiological characteristics.
- iii) Phase III: Clay addition into the SBR system and subsequent performance in relation to settling and microbiological characteristics.

4.0 MATERIALS AND METHODS

4.1 Set-up and operating conditions

4.1.1 Biomass and SWW

Two SBRs containing activated sludge biomass were fed synthetic wastewater (SWW) for the use of sludge generators. The activated sludge biomass seed was sourced from the WWTP located in the suburb of Bromley, Christchurch, New Zealand while a SWW recipe adapted from Wang *et al.* (2010) was used as feed at two different strengths and with two different main carbon sources, glucose and sucrose (Table 4.1). The feed strength was a function of different runs as shown in Table 4.2. A synthetic wastewater was used for ease of control of its constituent parameters and was specifically chosen to attempt to induce bulking (Table 4.1). Having a readily degradable substance such as glucose has been shown to induce bulking (Gulez and de los Reyes III 2009) and was coupled with a low nutrient waste, used in the initial Runs 1.1, 2.1 and 2.2 (Table 4.2). The wastewater was increased to double strength in Runs 1.2-1.3 and 2.3 (Table 4.2) because a high carbohydrate waste has also been shown to induce bulking (Gulez and de los Reyes III 2009). In the final runs (1.4 - 1.8, and 2.4 - 2.9), the substrate was switched from powdered glucose to sucrose (in the form of white sugar) due to sugar being more conveniently available than powdered glucose. The correct amount of sugar to make up the equivalent amount of synthetic wastewater was calculated in order to keep the amount of carbon being fed to the biomass the same (Table 4.1).

Table 4.1: Synthetic wastewater chemicals.

Glucose					Sucrose		
Normal Strength			Double Strength		Double Strength		
Chemicals	mg/L	x200 Concentrate (g/200L)	mg/L	x200 Concentrate (g/200L)	Chemicals	mg/L	x200 Concentrate (g/200L)
Glucose	450	90	900	180	Sucrose	825	165
NaHCO ₃	200	40	400	80	NaHCO ₃	400	80
NH ₄ Cl	15	3	30	6	NH ₄ Cl	30	6
KH ₂ PO ₄	5	1	10	2	KH ₂ PO ₄	10	2
MnSO ₄	5	1	10	2	MnSO ₄	10	2
MgSO ₄	5	1	10	2	MgSO ₄	10	2
FeCl ₃	5	1	10	2	FeCl ₃	10	2

Table 4.2: Duration (days) and feed of each run.

SBR 1			SBR 2		
Run	Duration	Feed	Run	Duration	Feed
1.1	71	G x 1	2.1	39	G x 1
1.2	23	G x 2	2.2	28	G x 1
1.3	27	G x 2	2.3	50	G x 2
1.4	31	S x 2	2.4	27	S x 2
1.5	29	S x 2	2.5	31	S x 2
1.6	12	S x 2	2.6	29	S x 2
1.7	30	S x 2	2.7	14	S x 2
1.8	18	S x 2	2.8	30	S x 2
			2.9	18	S x 2

Key for Table 4.2: *G*, glucose; *S*, sucrose; *x1*, normal strength; *x2*, double strength.

The synthetic wastewater concentrate was synthesized by dissolving the required amounts of chemicals (Table 4.1), in 2 L of water. This was then put on a shaker for 15 minutes at a mixing speed of 115 vibrations per second. It was then stored in its concentrated form and kept in a sealed bottle in the fridge for a maximum of 10 days. Each 2 L bottle of SWW concentrate made up 200 L of feed when mixed with water (Table 4.1).

4.1.2 SBR system configuration and operation

The SBR system consisted of;

- A wastewater feed tank with a 220 L capacity;
- A tank with the wastewater feed with a cooler;
- Two 20 L capacity SBRs;
- Solenoid valves;
- Float switches for each SBR;
- Aeration stones and metal mixers for each SBR;
- DO meters;
- Pumps for transfer of wastewater to SBRs and mixing pumps for wastewater; and
- A computer control box and lab view program for each SBR.

A schematic of the layout is shown in 4.1 below.

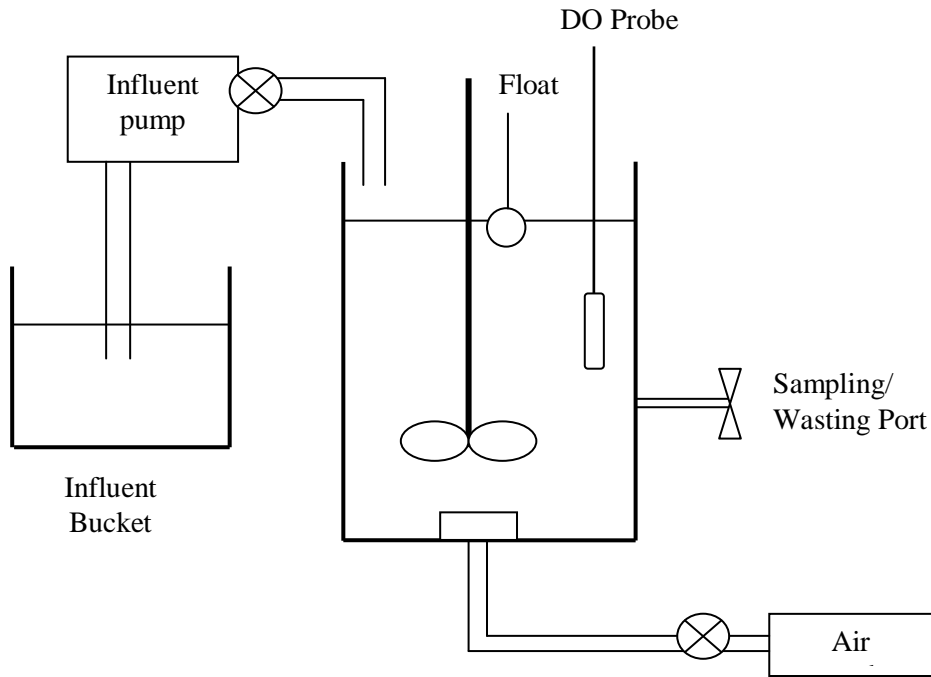

Figure 4.1: Sequencing batch reactor set-up.

The SBRs were constructed so that they modelled as closely as possible the actual process used for secondary wastewater treatment occurring in a WWTP. The cycles for each of the reactors were identical and controlled using a computer using the lab view program. Each cycle ran for a total of 8 hours and consisted of the following 4 stages:

- Feeding of synthetic wastewater into the reactor (3 minutes);
- Mixing and aerating (412 minutes);
- Settling/solids separation (60 minutes); and
- Decanting (5 minutes)

To initiate each SBR's operation, 10 L of biomass (Section 4.1) was added to each reactor along with 10 L of synthetic wastewater, according to each run (Table 4.2). The wastewater was pumped from the feed tank into the reactors until the float switch was triggered at a set volume of 20 L. The maximum filling time possible was programmed for three minutes to protect against overflow (that is, if the float switch failed, the reactors would not continue filling). To counteract the tendency of the feed to settle in the wastewater feed tank, a mixing pump was set to mix the feed for 5 minutes (while the SBR was in the decanting stage) before the feed was pumped into the reactors. Additionally another separate mixing pump was set to mix the tank for 5 minutes every hour.

Post-filling, the SBRs were mixed and aerated for 412 minutes. After the aeration stage they were allowed to settle for 60 minutes and once settled, 10 L of the supernatant was drained off from the decant port for a total of 5 minutes, thus completing the full cycle of 8 hours. During the decanting stage, the mixing pump in the wastewater feed tank also came on for 5 minutes, as mentioned above. To ensure 10 L was decanted, a tube cut to an appropriate length to reach to the volume of 10 L was extended down from the decanting port inside each SBR. After the decanting stage, the cycle was repeated continuously for the duration of each run (Table 4.2).

The two SBRs were run continuously until either they reached total suspended solids (TSS) of around 1500-2000 mg/L (deemed low enough to necessitate a re-start of operation) or until they were no longer needed. At that point, the SBRs were stopped, drained, cleaned and re-started with fresh sludge as necessary. Although both SBRs were operated under identical conditions, they behaved as separate biological entities, reaching the critical low TSS

concentration at different times. For this reason, each run was considered a separate run in each of the reactors. The cycle runs and duration are shown in Table 4.2.

4.1.3 Function of each reactor run

The SBRs were run multiple times for different purposes across each of the runs. Initially they were run to gage how the reactors functioned in response to the operating conditions and the synthetic feed, (Runs 1.1 & 2.1 -2.2) before any clay testing was done (Table 4.2 & 4.3). Runs 1.2-1.7 and 2.3-2.8 were used to generate and supply sludge for the bench-scale clay tests, whereas the final runs (1.8 and 2.9) were used to examine the effects of clay on the SBRs (Table 4.3).

Table 4.3: Reactor runs with their associated functions.

SBR 1		SBR 2	
Run	Function	Run	Function
1.1	Prelim. Data	2.1	Prelim. Data
1.2	SBR Parameters	2.2	Prelim. Data
1.3	Clay B.T	2.3	Clay B.T
1.4	SBR Parameters	2.4	SBR Parameters
1.5	Clay B.T	2.5	SBR Parameters
1.6	SBR Parameters	2.6	Clay B.T
1.7	Clay B.T	2.7	SBR Parameters
1.8	Clay SBR	2.8	Clay B.T
		2.9	Clay SBR

Key for Table 4.3: *Prelim.Data, preliminary data; SBR Parameters, sequencing batch reactor parameters; Clay B.T, clay batch test parameters; Clay SBR, clay sequencing batch reactor parameters.*

4.2 Analytical methods

pH and COD (chemical oxygen demand) were recorded on the SWW (Section 4.2.1). These along with TSS, volatile suspended solids (VSS), sludge volume index (SVI) and dissolved oxygen (DO) were recorded on the SBRs (Section 4.2.2).

4.2.1 SWW analysis

4.2.1.1 pH of the SWW

The pH was recorded across reactor runs fed with each of the strengths of wastewater (Table 4.1 & 4.2). Four observations across the runs were taken on the glucose-normal strength, 6 on the glucose-double strength and 10 on the sucrose-double strength. The pH meters were calibrated before use and the buffers refreshed regularly.

4.2.1.2 COD of the SWW

The COD was measured for all three different SWWs (Table 4.1). The samples used for COD analysis were taken when the concentrate was first added and made up in the feed tank (day 1), and after being in the feed tank for 3 and 5 days. This was to observe if there was a major deterioration in the COD over time to ascertain how often the SWW feed tank needed to be refreshed. The COD on the SWW was only tested on day 5 on the first feed trialled (glucose-normal strength, Table 4.1 & 4.2), as it was decided that the SWW feed tank would be replenished more frequently than once every 5 days (see Section 5.3.2). The sample for COD analysis was taken after the SWW feed tank had been thoroughly mixed. To filter the sample, approximately 10 mL was taken into a syringe and filtered with a nylon 0.5 μm filter screwed onto the syringe. Each sample was then preserved with one drop of concentrated sulfuric acid (H_2SO_4) and refrigerated for up to 10 days until the COD test was carried out.

4.2.2 SBR analytical methods

4.2.2.1 pH in the SBRs

pH was measured in the reactors every four to seven days until sufficient data was obtained. The pH meters were calibrated and buffers refreshed as above (Section 4.2.1.1).

4.2.2.2 COD in the SBRs

Analysis of the soluble COD present in the SBRs was performed to establish a profile over the mixing stage of each cycle. This was done for each run until sufficient data was obtained to establish a profile (note that samples were taken hourly after the systems had been fed). The initial sample was taken approximately 15 minutes after the reactors had been fed to give them time to thoroughly mix.

Each sample was taken from the reactor from the lowest port to ensure the sample was well mixed. Two 100 mL beakers full of sample was drawn and poured back into the reactor before the final sample used for analysis was taken. Filtering and preservation was carried out as above (Section 4.2.1.2).

4.2.2.3 DO

The computers were operated such that the DO was recorded continuously throughout each run. The probes were cleaned and calibrated weekly. The amount of DO going into the reactors was kept between 2.0 and 3.0 mg/L.

4.2.2.4 TSS and VSS

The TSS and VSS were calculated according to Standard Methods (2005). To measure the TSS, 10 mL of sample was taken from the reactor and mixed with 90 mL of deionised water

in a 100 mL measuring cylinder. To ensure the samples taken from the reactors were well mixed, the same method was used as for collection of samples for COD analyses from the SBRs (Section 4.2.2.2). The sample was slowly poured out and subsequently filtered through a dried and weighed glass fiber filter grade C (GFC) with a pore size of 1.2 μm . An extra 10 mL of deionised water was used to rinse the edges of the measuring cylinder to avoid any sample accumulating on the edges of the glassware. Each filter paper plus sample was then oven dried at 105 °C for 1.5 hours before being removed and weighed. Several blank samples were measured by filtering the same total volume used in the sludge samples, in the form of deionised water and then subjecting them to the exact same drying and weighing processes as the sludge samples. This was in order to account for the loss of any glass fibres being filtered through with each sample, reducing the weight of each glass fibre filter. The average of these blanks was calculated and then taken into account when calculating the TSS. The TSS taking into account the blank was calculated using the equation and below. The key is as follows:

Key for equation 1:

A	Mass of the filter (g)
B	Sample volume (mL)
C	Mass of sample plus filter post-evaporation (g)
D	Solids loss/gain (g)

Equation 1, TSS considering the blank:

$$\frac{[(C - A) - D] * 1,000,000}{B} = TSS_{mg/L}$$

After the filters had been weighed for the TSS calculation, the filtered samples were put in a furnace heated to 550 °C in order to determine the VSS. These were left in the furnace for between 1 to 1.5 hours before being removed and left to cool in desiccators for 30 minutes.

They were subsequently weighed and used to calculate the VSS. Both the TSS and VSS were calculated generally on a Monday to Friday basis for the duration of each run. The equation for VSS is as follows with a separate key below:

Key for equation 2:

A	Weight before ignition (g)
B	Sample volume (mL)
C	Weight post-ignition (g)

Equation 2, VSS:

$$\frac{(A - C) * 1000,000}{B} = VSSmg/L$$

4.2.2.5 SVI

To calculate SVI, 1 L of sludge was taken from each reactor during the mixing stage and settled for a total of 30 minutes in an Imhoff cone according to Standard Methods (2005). The sludge samples used for SVI and TSS and VSS were taken within half an hour of each other. To ensure the samples taken from the reactors were well mixed, the same method used for collecting samples for COD (in the SBRs), TSS and VSS was used (described in Section 4.2.2.2). After 20 minutes settling, a glass rod was run gently around the edges of the cone where the supernatant was clear, to loosen any material that settled around the edge. After 30 minutes elapsed, the volume of settled sludge was recorded and used along with the VSS to calculate the SVI (Equation 3). The SVI along with the TSS and VSS was also generally taken Monday to Friday of each run.

Equation 3, SVI:

$$\frac{\text{Settled sludge volume (mL/L)} * 1000}{\text{Suspended solids (mg/L)}} = \text{SVI (mL/g)}$$

4.3 Microbiological parameters

4.3.1 Calculation of filament length

A method for estimating total filament length in a sample was adapted from Nedoma *et al.* (2001). This involved using a microscope to count the number of times filamentous microorganisms intersected a cross hair of known length, in a known volume of sample through use of a pre-calibrated counting chamber. The number of filaments per sample could then be converted into meters per mL by inputting the number of intercepts observed into equation 4 shown below. The key for equation 4 is as follows:

Key for equation 4:

N	Number of intercepts
T	Test bar length (μm)
A	Area examined (μm^2)
V	Volume (mL)

Equation 4, filament length (m/mL):

$$(\pi/2) * (N/T) * A * 10^{-6} / V = \text{CLF(m/mL)}$$

The protocol for estimating total filament length was as follows:

- From the SBRs, a 10 mL sample was extracted for microscopic examination. To ensure the samples were well mixed, the same technique was used as in Section 4.2.2.2 for COD, TSS and VSS sample extraction. The samples were taken at the same time as samples for TSS and SVI were taken.

- 10 mL of water was added to each sample to dilute it to 50 % concentration in order to make microscopic examination easier. This was then thoroughly mixed before microscopic examination. Samples were taken within 20 minutes of each other and then kept refrigerated for up to 4 hours before being used.
- When the samples were unable to be processed in the same day, they were preserved with Lugol's Iodine solution, made up in the following way: 6 g Potassium Iodide and 3 g Iodine were dissolved in 10 mL distilled water and this was then made up to 900 mL with distilled water. The samples to be preserved were done so by adding 2 mL of Lugol's Iodine to 10 mL of sludge and 8 mL deionized water (diluting it by half as above). The sample was then well mixed and stored in a refrigerator at 4 °C for a maximum of two weeks before microscopic analysis.
- To prepare each slide for microscopic examination, one drop of sample was taken using a wide-mouthed pipette and used to fill the counting chamber. Thirteen randomly selected fields of view were examined at 400x magnification on each slide and the number of times the filaments intercepted the cross hairs were recorded.
- The filaments crossing the cross hairs at all depths were identified by zooming in and out in each field of view through the full depth of field of the counting chamber. The filaments were categorized as; fungi, protozoa and those that were readily apparent as different types of bacteria. Although this data was recorded, no statistical analysis was done investigating proportions of different filaments.
- From the sample taken for analysis, 6 sub-samples were taken and 13 fields of view examined from each of these, making a total of 78 fields of view examined across 6 sub-samples for each treatment.

- The number of filaments intersecting the cross hairs; the length of cross hairs and the volume of the counting chamber were used to calculate the total filament length (m/mL) (see Equation 4 above). In addition, the dilution of the initial sample was taken into consideration in this calculation.

4.3.2 Authentication of preservation method

In order to assess whether the Lugol's Iodine solution was effective at preserving the sludge samples for microscopic examination at a later date, a single sludge sample was examined according to the protocol outlined in Section 4.3.1 This was done before preservation and after having been preserved and refrigerated for two weeks. To statistically test the difference between the two samples, a one way repeated measured ANOVA was performed on total filament length.

4.3.3 The relationship of SVI to abundance of filamentous bacteria

Two SBRs were run for 2.5 weeks to investigate the link between SVI and total filament length. SVI was recorded daily while filament length was recorded on days 5, 8, 11, 13, 17 and 19 according to the protocol outlined in Section 4.3.1. Correlation of SVI and filament length was assessed using a Pearson's correlation test.

4.4 Clay settling batch tests

In order to assess the influence of clay on the activated sludge settling properties, a series of batch tests were carried out on sludge extracted from the bench-scale SBRs. A key aspect of these tests was to mimic as closely as possible the SBRs in terms of their operation. Runs were carried out over a five day testing period, consisting of either 2 or 4 different treatments depending on the stage of the batch test (Table 4.4). Preliminary batch tests examined only

the settling parameters (modified SVI) where the secondary tests examined both settling and filament length.

In the secondary section of batch tests, the relationship between filament length and SVI was assessed on the SBR supplying the sludge for the batch test. SVI was recorded daily and filament length was recorded on day 6, 8, 10, 12 and 15 and then correlated (as in Section 4.3.3). This was to assess whether the sludge used for the batch test was experiencing filamentous bulking.

4.4.1 Clay batch test system configuration and operation

The clay-settling system consisted of the following:

- Four to six 1 L beakers for the clay-sludge treatments;
- Aeration stone and magnetic mixers for each beaker; and
- Volumetric (graduated) cylinders for settling observations

For practical purposes, magnetic mixers with stirring fleas were used for the system and each of the treatments was kept at the same stirring speed (dial 4 on the stirrer). The amount of air supplied to each treatment was not monitored but judged to be adequate by a good degree of visual turbulence. The air supply was attenuated by clamps on the air tubing supplying each treatment.

The initial sludge for each run was sourced from the bench-scale SBR with the highest suspended solids concentration. The TSS, VSS and SVI were measured on the sludge from the SBR. To start each treatment, 800 mL of sludge was used and this was taken shortly after the SBR system had been fed with synthetic wastewater.

The clay used was sourced from the Port Hills (Loes clay), Christchurch, New Zealand. The name Loes refers to the type of clay. It was dried and ground with any large bits of stone and vegetation removed. A 10 % clay suspension was made by mixing 10 grams of clay in 100 mL water. For the first sections of settling tests, the treatment concentrations investigated were 0.4, 2.0 and 5.0 g/L. Before any of the 5 day batch tests were carried out, an assessment was done on the immediate effect of clay on settling, comparing the above treatments. The clay concentrations were added, mixed and left to stand for 30 minutes and their settling volume recorded.

To initiate the 5 day batch tests, the clay was added only once, on the very first day of each run. In the preliminary batch tests (Table 4.4), to treatment 1, 3.2 mL of clay suspension was added, to treatment 2, 16 mL of clay suspension was added and to treatment 3, 40 mL of clay solution was added. In order to keep the total volume in each of the treatments consistent, 40 mL of water was added to the blank, 36.8 mL of water to treatment one and 24 mL of water to treatment two. Thus the total volume of water and/or clay added to each treatment was 840 mL.

In the secondary batch tests, 3 replicates of the blank and 5.0 g/L clay suspension were compared to each other (Table 4.4). This was in order to see if there was a statistically significant difference between two treatments in both filament length and (Section 4.3.1 & 4.4.2.5) and setting in the form of modified SVI (Section 4.4.2.4). The treatments and replicates were limited to two and three respectively due to equipment availability and practicality of the set up. Two of these secondary batch tests were carried out however only one is reported on (Section 5.5.2) because the sludge health collapsed completely in the first trial and the results deemed irrelevant. Statistical analysis was carried out on the remaining

secondary clay batch test on both modified SVI as a measure of settling (Section 4.3.5) and on the filament length (Section 4.3.6).

Table 4.4: Primary and secondary 5 day clay batch tests.

	Preliminary	Secondary
Treatments	Blank, 0.4, 2.0 & 5.0 g/L	Blank & 5.0 g/L
Replicates of treatment	1	3
Parameters	Modified SVI	Modified SVI & filament length

The system was run for a total of six hours per day. The steps in each six hour cycle were as follows:

- I. The system was mixed and aerated for three hours followed by settling for one hour;
- II. During the first 30 minutes of settling, 500 mL of sludge was poured into a 500 mL measuring cylinder and the volume to which it settled was recorded after both 15 and 30 minutes;
- III. Two hundred mL of supernatant was removed and replaced by 200 mL of synthetic wastewater;
- IV. After the full hour of settling, the system was then mixed and aerated for a further two hours before being allowed to settle overnight; and
- V. The cycle was repeated for the designated number of days according to each run.

4.4.2 Batch test analytical methods

The parameters measured were COD, TSS, VSS, modified SVI and microbiological parameters (total filament length) and were all calculated following the same protocols above (Section 4.4.2.1, 4.2.2, 4.2.2.4 - 4.2.2.5 & 4.3.1), excluding modified SVI (Section 4.4.2.4).

4.4.2.1 pH

pH was taken on each of the trials across the different approximately 30 minutes into the mixing cycle.

4.4.2.2 COD sampling stages

The COD profile was monitored in each treatment to establish whether the bench-scale clay system was behaving similarly to the SBRs during the different stages within each cycle. During second sections of clay settling tests, samples were taken on day 1, and 5 from each of the treatments for COD analysis at the following stages:

- I. The beginning of each cycle, approximately 15-30 minutes after initial start-up;
- II. Before the systems were settled, approximately 5-15 minutes before they were stopped;
- III. After the treatments had been fed with synthetic wastewater, approximately 15-30 minutes after mixing and aerating; and
- IV. Before the systems were settled overnight, approximately 15-30 minutes before they were stopped.

4.4.2.3 TSS and VSS

The TSS and VSS were calculated daily for each treatment. To ensure each sample taken for each treatment was well mixed, the stirring speed was initially increased in each beaker, so that each mixer stirred at a higher speed for approximately 20 seconds before sampling.

4.4.2.4 Modified SVI

A modified SVI was calculated from the 30 minute settling data (Section 4.2.2.5) to monitor changes in settling over the course of each run. The calculation below is based on the equation from Standard Methods (2005). The settling volume of 1 L in an Imhoff cone was changed to a settling volume of 500 mL in a measuring cylinder. A mixed model repeated measures ANOVA using SPSS software was carried out on the modified SVI in the secondary clay batch tests to examine differences in settling over the 5 days and also between treatments.

Equation 5, Modified SVI:

$$\frac{30 \text{ minute settling volume} * 1000}{VSS(mg/L)}$$

4.4.2.5 Microbiological assessment

For the secondary run of clay batch tests, where multiple replicates of the blank were being compared to multiple replicates of the 5.0 g/L treatment (Section 4.4.1), a mixed model repeated measures ANOVA was performed using SPSS software as for modified SVI above (Section 4.4.2.4), to establish if there was a significant difference in filament length in blank samples compared to clay treated samples. Change in filament length over time was also investigated. The same method for estimating total filament length (Section 4.3.1) was used for each sample. Samples were taken for microbiological analysis from each of the treatments

on days 1, 3 and 5 of the batch tests. As outlined in Section 4.3.1, different types of filaments were recognised but statistical analysis was only performed on the total length of filaments.

4.5 SBR clay tests

The extent of experimental testing of the effects of clay on the sludge had been limited to observing the settling and microbiological parameters in the bench-scale batch tests (Section 4.4). It was therefore necessary to observe how the clay would affect the sludge in the SBR reactors. Due to space and equipment restrictions, the clay testing in the SBRs was limited to a single run in two SBRs.

Before any clay was added to the SBR, they were run till they reached a ratio of VSS:TSS of 0.82, which was comfortably away from its possible critical VSS:TSS ratio of 0.90, before reactor collapse, and above the reactor start up VSS:TSS ratio of around 0.75-0.80 (see Section 5.3.5). Once this ratio was reached (10 days running time) the SBRs were mixed together to ensure that there was no difference between the biomass in each SBR.

The clay was added to one SBR, while the other SBR was kept as a control, without clay. The amount of clay added was calculated on a case-by-case basis maintaining the ratio of VSS:TSS at around 0.80-0.82. On average the clay was added every 2-3 days to maintain the ratio.

The two SBRs were set up and run according to the protocol above (Section 4.1). The TSS, VSS and SVI were recorded every weekday along with a microbiological examination being carried out approximately every four days, according to protocols outlined in Section 4.2.2.4–4.2.2.5 and 4.3.1 respectively. A Pearson's correlation between filament length and SVI was

run, however the SBRs had to be stopped earlier than expected due to sludge deterioration. The correlation was not reported as it was deemed to have too few data points to be accurate. Because there was only one replicate of each treatment, it was decided that no statistical analysis comparing the blank and clay treatments could be done and therefore the results for this section are limited to visual observations and interpretation of trends.

5.0 RESULTS AND DISCUSSION

5.1 General observations and parameters

The SBRs were run twice in a series of preliminary test runs (Section 4.1) before any clay settling tests were carried out, to observe how they behaved on a day-to-day basis in response to the synthetic feed and reactor set-up (Section 5.2 & 5.3 respectively). Throughout these preliminary (and the following) runs, basic parameters were recorded for both the SWW and the SBRs. Parameters measured on the SWW included COD and pH. On the SBRs, the same parameters were measured along with DO. It is important to note that not all parameters were recorded on all the reactor runs, however sufficient data was collected over time to assess how the reactors functioned.

5.2 SWW characteristics

5.2.1 Use of different strengths of wastewaters

Over the course of the experiments, three different strengths of SWW were used; glucose-normal, glucose-double and sucrose-double strength (Section 4.1.1, Table 4.1 & 4.2). These strengths were all based around the original SWW recipe taken from Wang *et al.* (2010). The reason for switching from the glucose-normal to glucose-double strength wastewater in the experiments was because it was hypothesised that by increasing the amount of carbohydrate in the SWW dramatically, it may induce bulking at a faster rate than the low carbohydrate waste. Both a low carbohydrate waste (Runs 1.1, 2.1-2.2) and a high carbohydrate waste used in the remaining runs (1.2-1.1.8 and 2.3-2.9), have been shown to help induce bulking (Wang *et al.* 2010, Gulez and de los Reyes III 2009 respectively). The reason for switching from glucose to sucrose as the main carbon source in the later runs (Table 4.2), was because powdered sucrose was more easily obtainable than powdered glucose. This reduced the cost of the treatments.

5.2.2 pH of the SWWs

The mean recorded pH values for all three wastewaters were between 6.8 and 7.3 (Table 5.1), showing the feed entering the SBRs was prepared at a relatively neutral pH. The observed pH for the normal strength glucose feed was similar to the findings of Wang *et al.* (2010) who reported a pH for their wastewater ranging between pH 6.7 - 7.2. The mean pH value is slightly higher than their largest pH; however, the difference is small and assumed to be unimportant in the general operation of the SBRs.

Table 5.1 Mean pH of different synthetic wastewaters used.

Carbon source	Glucose		Sucrose
Concentration	Normal Strength	Double Strength	Double Strength
Mean pH	7.3	7.2	6.9
Sample size	4	6	10
Standard deviation	0.38	0.20	0.29

5.2.3 COD of the SWWs

The general trends observed in regards to SBR function and SBR measured parameters excluding COD, were similar across all reactor runs regardless of their main carbon source and strength of SWW feed. Table 5.2 shows the mean COD for each of the three freshly made synthetic wastewaters. Again, the normal-strength glucose feed, with an average value of 496 mg/L is similar to the COD value of between 432-480 mg/L reported by Wang *et al.* (2010).

Table 5.2: Average COD of different synthetic wastewaters used.

Carbon source	Glucose		Sucrose
Concentration	Normal Strength	Double Strength	Double Strength
Average COD (mg/L)	495	927	845

The SWW was monitored over 5 days to observe COD deterioration over time, with the goal of determining the frequency at which the SWW feed tank needed to be refreshed (Section 4.2.1.2). The decrease in COD was assessed to be insubstantial over three days but over 5 days was considered to be large, with a 30% reduction in the glucose normal-strength (Table 5.3). The feed tank was generally refilled every 3 days as the cooling mechanism in the feed tank seemed sufficient to keep the SWW at an appropriate temperature to prevent rapid loss of COD over 3 days. The COD was not recorded for glucose and sucrose double strength feeds after 5 days, since they were not left for that long in the feed tank before refilling for reasons previously mentioned.

Table 5.3: COD (mg/L) of the different strengths of wastewaters over time.

Carbon source	Glucose				Sucrose	
	Normal Strength		Double Strength		Double Strength	
Concentration	COD value	Overall % change	COD value	Overall % change	COD value	Overall % change
Day 1	510	-	931	-	842	-
Day 3	425	16.70%	825	11.4%	731	13.20%
Day 5	353	30.80%				

5.3 General SBR trends and parameters

Running the SBRs continuously produced trends in physical settling and solids concentrations which corresponded to observable reactor deterioration. The main trend observed was an increase in SVI and a decrease in TSS and VSS over the duration of each run (Section 5.3.5), ranging from 14-71 days (Section 4.1). In conjunction with this, the ratio of VSS to TSS approached 1.0 after typically starting from around 0.75-0.80 (Section 5.3.5). This meant that near the end of each reactor run all of the solids were volatile. These tendencies were observed across all reactor runs independent of the type of synthetic wastewater and will be discussed further using specific examples (Section 5.3.4-5.3.5).

5.3.1 pH of SBRs

The pH was recorded for runs 1.2-1.8 and 2.2-2.9 (Section 4.1). The mean pH of the sludge was 7.55 ± 0.16 . This shows that the SBRs were kept at a suitable, relatively neutral pH across these runs.

5.3.2 COD in the SBRs

The COD in the SBRs was monitored over time to gauge how the sludge performed over a complete mixing cycle and in response to the SWW used (Section 4.2.1.2). Figures 5.1-5.3 show the trends observed for each of the three wastewater strengths. Although not all data is shown, (as not all were taken on the full duration of a mixing cycle), this general trend was consistent across the runs for each of the different wastewaters.

Over the 6 hour mixing cycle, it was expected that the COD in the SBRs would fluctuate in response to feeding with the SWW. The trend observed for all of the three wastewaters was that the sludge demonstrated a peak COD value immediately after the systems had been fed with SWW, which then decreased over time as the microbes consumed the nutrients in the wastewater. There were slight differences between the three wastewater strengths in terms of this general trend. Glucose-normal strength used on Runs 1.1, 2.1 and 2.2 showed a very rapid decrease in COD approximately 15 minutes after feeding with SWW. In the specific examples below from Runs 1.1 and 2.1, this went from an input SWW COD of approximately 495 mg/L (Table 5.3) to 211-212 mg/L (Table 5.4 & Fig. 5.1). The COD became almost zero after 2-3 hours of mixing and then increased again towards the end of the cycle. It is clear that for this SWW strength that there were not enough organic nutrients for the microbes. The increase in COD towards the end of the cycle could possibly be due to

microbes becoming senescent and then being decomposed by other microbes as the food source from the SWW had already been depleted.

Table 5.4: Changes in COD (mg/L) over 5 hours with glucose-normal strength feed.

Time (hr) since SWW addition	COD SBR 1	COD SBR 2
0.25	211	212
1	16	116
2	2	30
3	8	0
4	10	1
5	61	20
Run number	1.1	2.1

In the runs with higher strength wastewaters (Fig. 5.2 & 5.3) the COD did not decrease fully at the end of the 6 hour mixing stage as it had done with the normal strength SWW (Table 5.4 and Fig. 5.1). This showed that there was an over-abundance of nutrients for the sludge microbes. This was a result of both a doubling of the ingredients used in the SWW recipe (Section 4.1), effectively doubling the nutrient supply for the sludge microbes, coupled with keeping the DO at a low enough level in the SBRs to achieve a DO profile as demonstrated below in Figure 5.4.

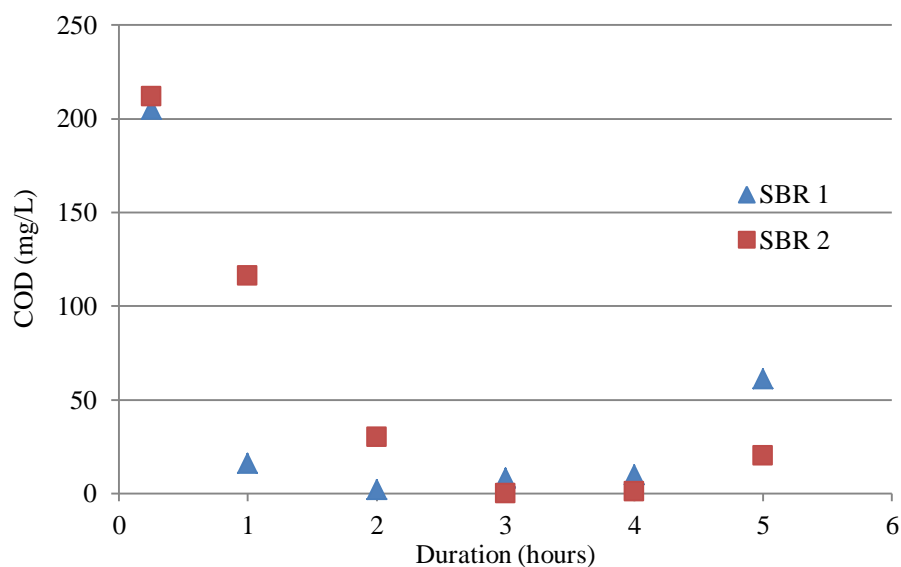

Figure 5.1: COD over time (5 hours) with glucose-normal strength feed on SBRs 1 & 2.

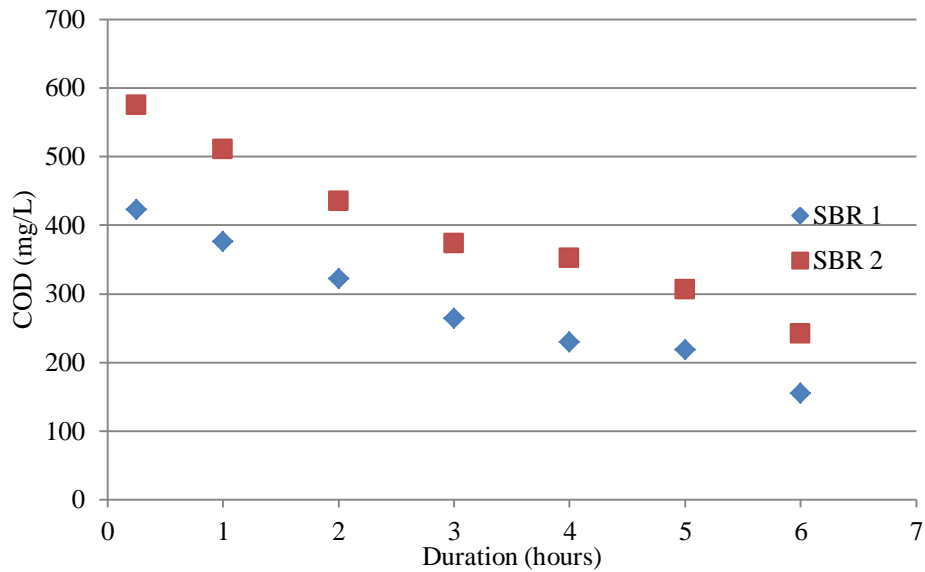

Figure 5.2: COD over time (6 hours) with glucose-double strength feed on SBRs 1 & 2.

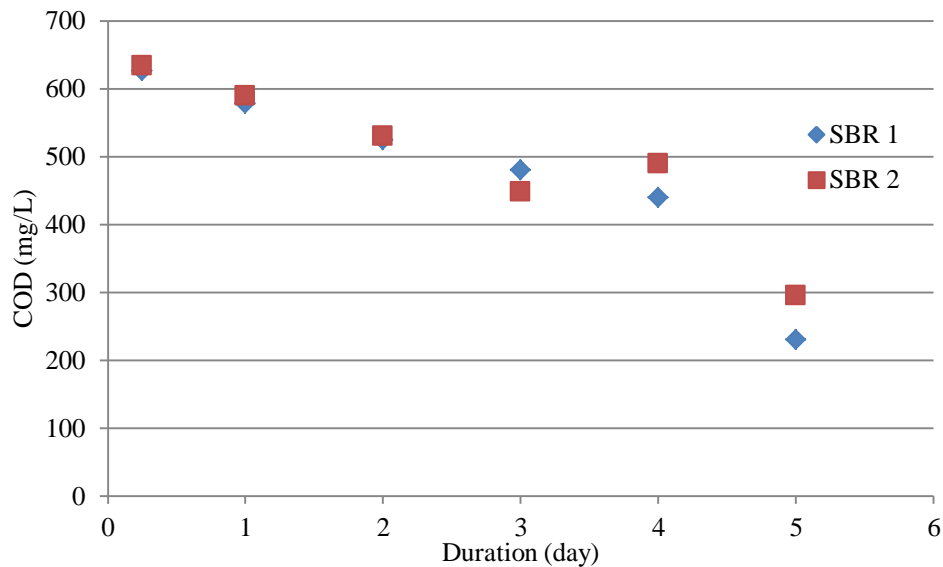

Figure 5.3: COD over time (5 hours) with sucrose-double strength feed on SBRs 1 & 2.

5.3.3 DO

The DO was recorded continuously for each run (Section 4.2.2.3). Towards the end of each run when the reactors were starting to deteriorate (indicated by lower solids concentrations and poorer settling), the DO started to increase closer to the end of the mixing cycle. This was probably due to the reduction of solids in the reactor over time (see Section 5.3.5), whilst a similar amount of oxygen was being added to the system. Once this was observed on the

SBR DO profile, the amount of oxygen entering the reactor was reduced to match the decrease in biomass. The increase of the DO tended to happen not long before the reactors would collapse and therefore became an indication of impending reactor failure. An example is given below of a DO profile showing a slight increase of the DO in the SBR over time, taken from a Run with double-strength glucose feed.

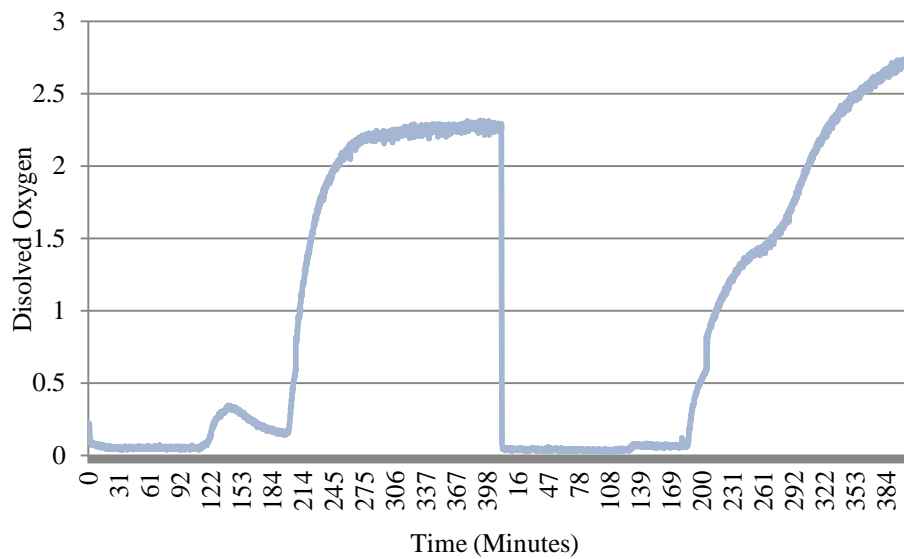

Figure 5.4: DO profile across two mixing cycles (412 minutes each).

5.3.4 SVI trends

During the preliminary reactor runs, one of the main trends was that the SVI eventually increased over time accompanied by a decrease in the TSS and VSS. This tendency is illustrated in Figures 5.5 and 5.6 for the preliminary Runs 1.1 and 2.2. The duration of these Runs was 70 and 28 days respectively, due to each reactor deteriorating at different rates. Although the length of these runs differed, there was a relationship between the point at which the SVI started to increase and the point where the VSS began to decrease. This trend was also observed over the other reactor runs (1.2-1.9 & 2.3-2.8).

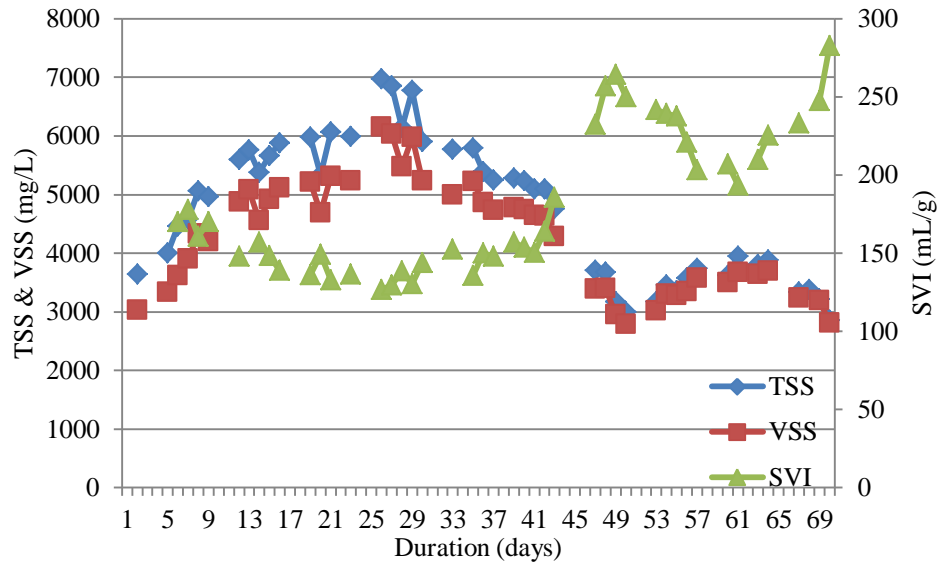

Figure 5.5: SVI and VSS on a preliminary run of SBR 1 (Run 1.1).

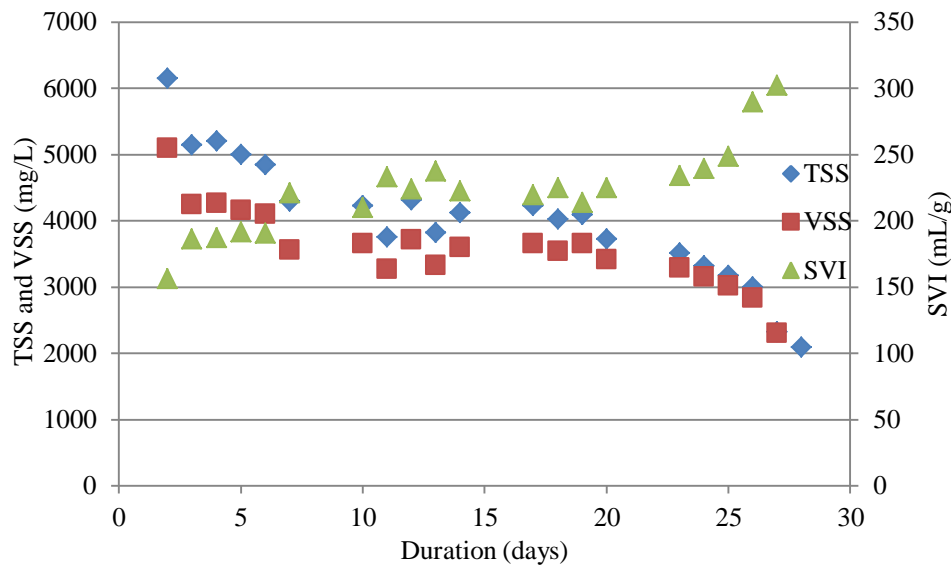

Figure 5.6: SVI and VSS on a preliminary run of SBR 2 (Run 2.2).

The SVI is a measure of activated-sludge settleability and can indicate a bulking sludge (Section 2.4). An SVI in the range of 50-150 mL/g indicates a good settling sludge (Clark *et al.* 1977) and as the SVI climbs outside this range it is possible that bulking is occurring. In this situation, the increase in SVI over time is thought to show that the systems started to experience bulking. Both runs had SVI values over 150 mL/g at some stage in their operation, with Run 1.1 deteriorating around day 37 when the SVI value consistently

exceeded 150 mL/g. In Run 2.2 the initial SVI value at reactor start up exceeded 150 mL/g, while appearing to stay stable in regards to SVI and solids concentration before deteriorating gradually and then more rapidly from day 18 onwards where the SVI rose further. It is possible that the sludge used for this reactor start-up was already experiencing bulking before being used in this experiment and this could account for the faster reactor deterioration in Run 2.2. Because no microbiological tests were made on these preliminary runs (Section 4.1.3), it cannot be confirmed that the increase in SVI was caused by an overgrowth of filamentous bacteria (Fig. 5.5 & 5.6).

The connection between solids decrease and SVI increase over time could be explained by a sludge with a higher SVI generally having poorer settling qualities than a sludge with a lower SVI. Because of this a smaller volume of sludge settles before the supernatant is decanted. This leads to solids being lost during decanting. Another possible reason for the decrease in TSS and VSS over time is that the conditions in the reactors may have been unfavourable for biomass growth which could have resulted in collapse of the activated sludge. This could be related to changes in the microbial community from an overgrowth of filamentous bacteria or be due to unfavourable conditions for sludge growth, resulting in solids loss through non-regeneration of the biomass. The synthetic feed was designed to induce bulking (Section 5.2.1), changing the microbiological composition of the sludge by encouraging filamentous micro-organisms to become abundant. Apart from causing settling to deteriorate, competition for resources from an over-abundance of filamentous micro-organisms could result in death of the beneficial microbes necessary for healthy sludge. It is possible that the loss of solids was a combination of these two processes, i.e. loss of solids through sampling and decanting, and loss of solids due to death of beneficial micro-organisms, most likely as a result of bulking caused by filamentous microbes.

5.3.5 VSS and TSS vs. SVI

Along with the SVI increase and the solids decrease over time, the ratio of VSS to TSS also changed over time (Fig. 5.7 & 5.8). This went from around 0.75-0.80 at the reactor start up (i.e. around 80% of the solids were volatile (VSS) and 20% were non-volatile), to a ratio of 1.00 (mentioned above in Section 5.3). It appeared that when the ratio reached a critical level, (around 0.90 - 0.92), a sharp increase in SVI occurred (Fig. 5.7 and 5.8).

The change in the ratio can be related to the use of synthetic wastewater. The initial sludge used to seed the reactors was sourced from the Christchurch WWTP (Section 4.1) which contained inorganic matter such as grit. In an activated sludge WWTP, a portion of non-volatile solids would constantly be introduced. Feeding the SBRs with a SWW containing no grit meant that no non-volatile solids were being re-introduced to the system throughout their entire operation. Over time, non-VSS inevitably decreased through sampling and decanting, resulting in the trend observed (Fig. 5.5-5.8).

It is possible that the increase in SVI occurred when the VSS:TSS ratio reached a critical level (before reactor deterioration) and it could contribute to bulking. Thus, there may be merit in having a certain amount of grit in the system to help prevent bulking. This supports the hypothesis that adding clay solution to activated sludge may help with healthy floc formation since clay and grit may act in a similar way (Section 2.7).

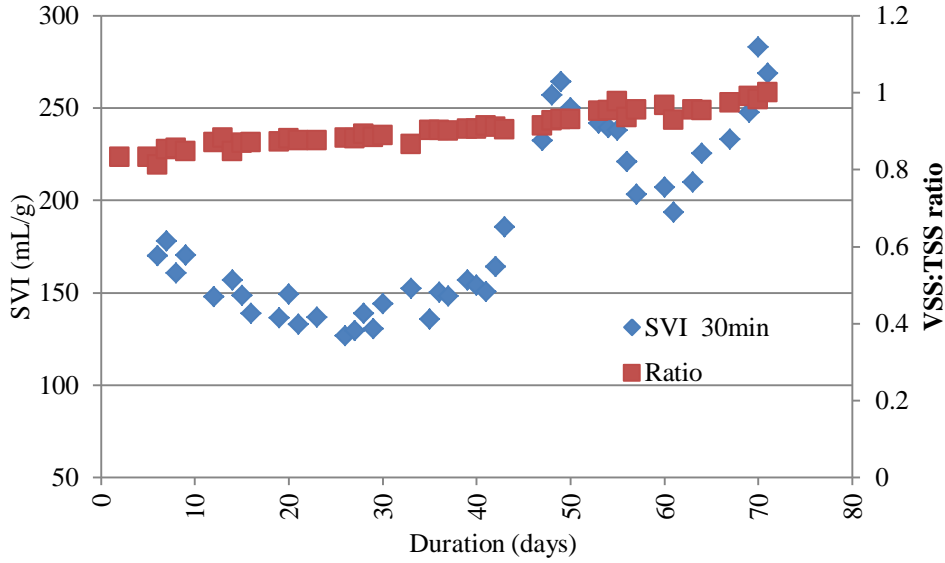

Figure 5.7: SVI and ratio of VSS: TSS on a preliminary run of SBR 1.

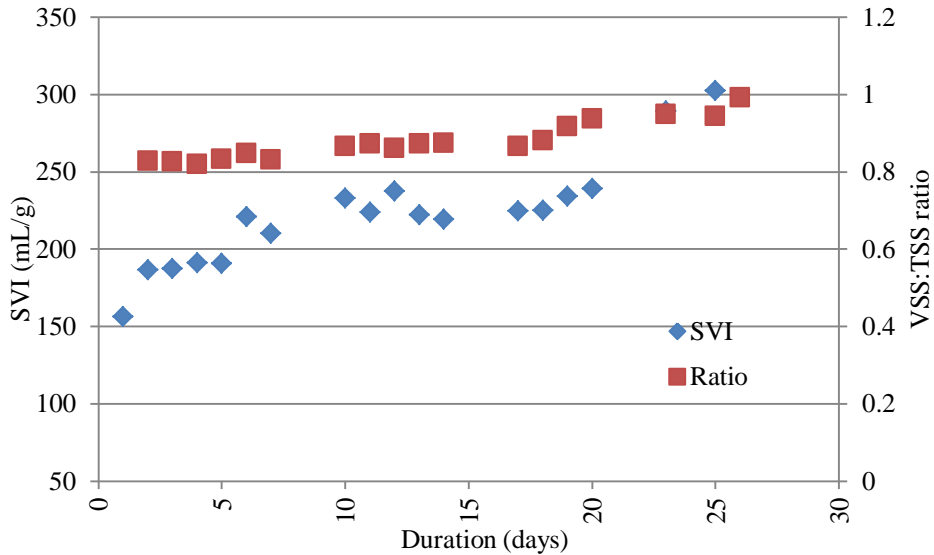

Figure 5.8: SVI and ratio of VSS: TSS on a preliminary run of SBR 2.

5.4 Microbiological data with SBRs

5.4.1 Authentication of the microbiological preservation method

In order to assess whether Lugol's Iodine solution was effective at preserving the sludge samples for microscopic examination at a later date, a sludge sample was examined according to the protocol outlined in section 4.3.1. The sample was examined on the day of preservation and then after refrigeration for 14 days.

A one way repeated measure ANOVA showed that there was no significant difference ($P=0.613$) between the total filament length of all species of filamentous micro-organisms in the sample before and after preservation (Table 5.5). The standard deviation is large because the fields of view examined to record intercepts from which filament length was calculated (Section 4.3.1), contained from one to as many as 30 filaments. It is concluded therefore that Lugol's Iodine solution was a reliable preservative for all wastewater samples in this study.

Table 5.5: Sample size, mean and standard deviation of total length of filamentous micro-organism (m/mL) in samples treated with Lugol's Iodine solution at 1 and 14 days

	N	Mean	S.D.
Day 1	78	134.9	82.3
Day 14	78	141.4	85.8

5.4.2 SVI Related to Filamentous Bacteria Abundance

In order to assess whether an increase in SVI (as seen in Fig. 5.5 - 5.8) was caused by filamentous bulking, additional runs of 2.5 weeks duration were made with both SBRs. Filament length and SVI were measured from day 5 to day 19 (Section 4.3.3). The hypothesis was that an increase in filament length caused an increase in SVI.

The result was that the SVI increased as total filament length increased (Fig. 5.9 & 5.10). A Pearson's correlation analysis on average filament length (m/mL) and SVI resulted in a correlation coefficient of 0.85 in SBR 1 and 0.84 in SBR 2. This positive correlation supports the hypothesis of a link between filament length and SVI and explains the poorer settling qualities associated with an increase in SVI. The increase in filamentous micro-organisms is therefore not a result of increased solids concentration (as they tend to decrease over time (as

happened in this run but is not displayed)) but is more likely explained by an increase in filamentous bacteria.

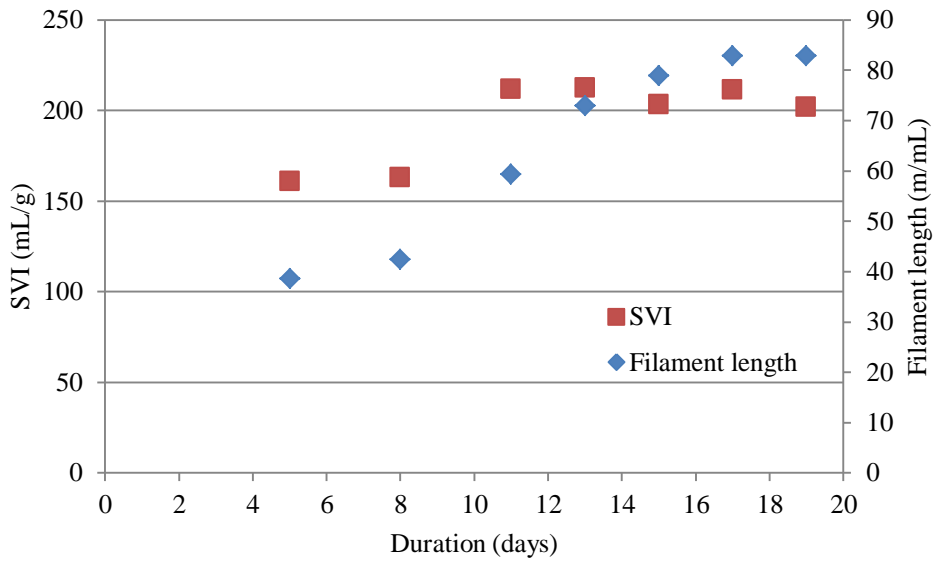

Figure 5.9: Relationship between filament length (m/mL) and SVI over time in SBR 1.

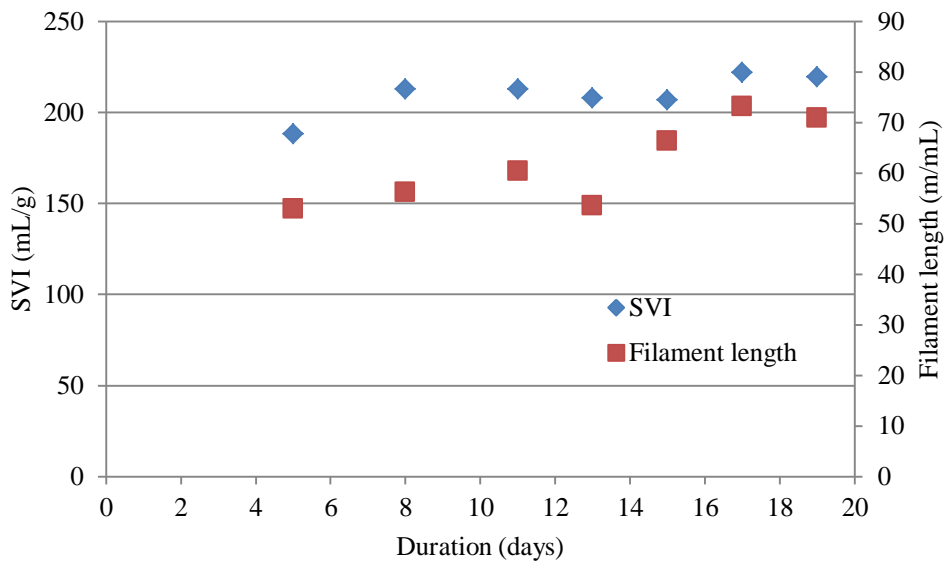

Figure 5.10: Relationship between filament length (m/mL) and SVI over time in SBR 2.

5.5 Clay settling batch tests

After collection of data on the SBR trends and parameters (Section 5.1-5.4), clay settling batch tests were carried out (Section 4.4). These smaller scale tests outside the SBRs were

run in order to have more replicates for statistical analysis. There were two stages of batch tests; preliminary (Section 5.5.1) and secondary (Section 5.5.2).

5.5.1 Preliminary clay batch tests

The purpose of the preliminary batch tests was to see what effect (if any), the clay had on the physical settling properties of the sludge. Three different concentrations of clay suspensions were investigated; 0.4, 2.0 and 5.0 g/L and these were compared to a blank treatment with no clay (Section 4.4.1). After adding the clay to 800 mL of sludge, mixing and settling for 30 minutes, it was clear it produced an immediate visual effect on settling (Fig. 5.11). The most noticeable effect was seen at the highest concentration (5.0 g/L) which settled to 220 mL compared to the blank which settled to 420 mL.

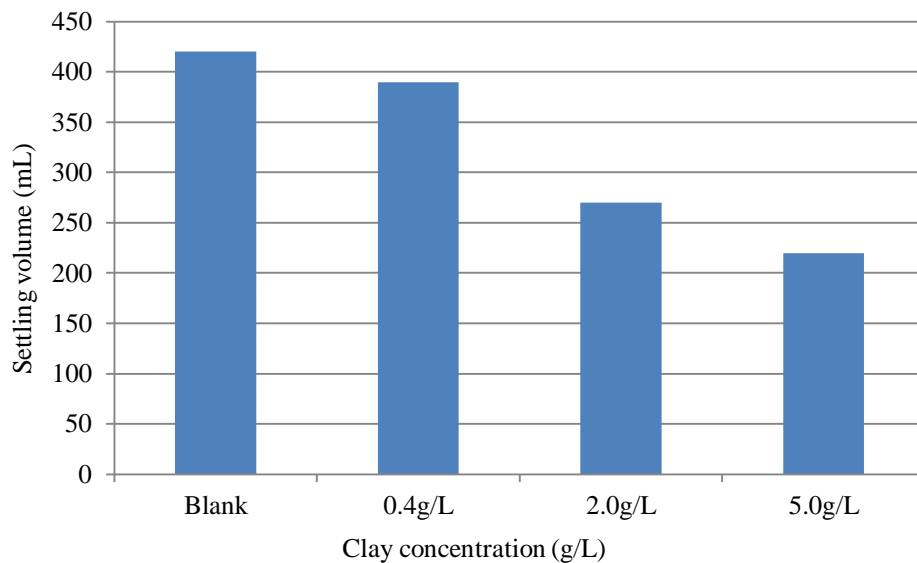

Figure 5.11: Settling volumes of different clay concentrations after 30 minutes.

Once it was established that the clay had an immediate positive effect on settling, 5 day batch tests were run using the same clay concentrations to observe settling over time (Section 4.4.1). Figure 5.12 demonstrates this effect in the form of a modified SVI (Section 4.4.2.4).

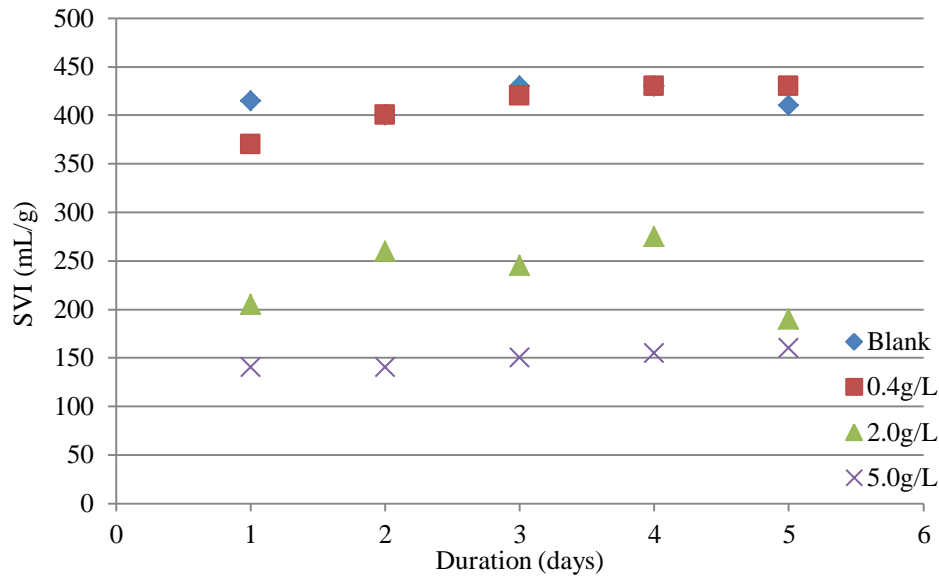

Figure 5.12: Effect of different concentrations of clay suspension on sludge over 5 days expressed in the form of modified SVI.

There seemed to be little difference between the 0.4g/L treatment and the blank; therefore it was ruled out as a clay concentration to investigate further. The 2.0g/L treatment produced good settling results almost equalling the 5.0g/L treatment by day 5 (Fig. 5.12). However, only the 5.0g/L concentration was chosen for further investigation as it had the most obvious impact on improving settling. This is consistent with what was seen in the preliminary test (Fig. 5.11).

5.5.2 Secondary clay settling batch tests

The final stage of clay tests consisted of 3 replicates each of the 5.0 g/L treatment and the blank over 5 days. Filament length was investigated along with the physical settling properties (Section 4.4.1). It was hypothesised that if the clay affected filament length, then it would be most obvious at 5.0g/L.

5.5.2.1 pH and COD of batch test

The mean pH for the blank treatments across the testing period was 7.2 ± 0.12 and 6.9 ± 0.19 across the clay treatment. The COD over different stages in the batch tests is presented below for days 1 & 5 (Section 4.4.2.2). It appears to be similar to the COD in the SBRs (Section 5.3.2).

Table 5.6: COD (mg/L) on day 1 of the batch tests in each treatment at 0.25 hours, before feeding with SWW, after feeding with SWW and at 5.5 hours in the mixing cycle.

Day 1	Blank	0.25 hr	Before feed	After feed	5.5 hr
Blank	B (1)	515	176	598	105
	B (2)	557	443	529	377
	B (3)	598	416	491	290
Clay	C (1)	252	90	232	66
	C (2)	594	210	412	84
	C (3)	501	360	501	289

Table 5.7: COD (mg/L) on day 5 of the batch tests in each treatment at 0.25 hours, before feeding with SWW, after feeding with SWW and at 5.5 hours in the mixing cycle.

Day 5	Blank	0.25 hr	Before feed	After feed	5.5 hr
Blank	B (1)	412	190	337	137
	B (2)	559	337	488	401
	B (3)	373	230	419	249
Clay	C (1)	328	100	264	136
	C (2)	242	104	283	147
	C (3)	416	204	398	171

5.5.2.2 Microbiology and settling in the clay batch test

A comparison of filament length (recorded on day 6, 8, 10, 12 and 15), and SVI on the SBR run sourcing the batch tests (as in Section 5.4.2), was done to see if the sludge was bulking before being used for the batch tests (Section 4.4.2.5). The sludge was taken for the batch test

on day 18, when the ratio of VSS:TSS was 0.94. A Pearson's correlation on filament length and SVI showed they increased together (correlation coefficient of 0.85) (Fig. 5.13). This combined with high SVI values (>150), across the entire run (Fig. 5.14), indicates the sludge used for the batch tests was likely bulking.

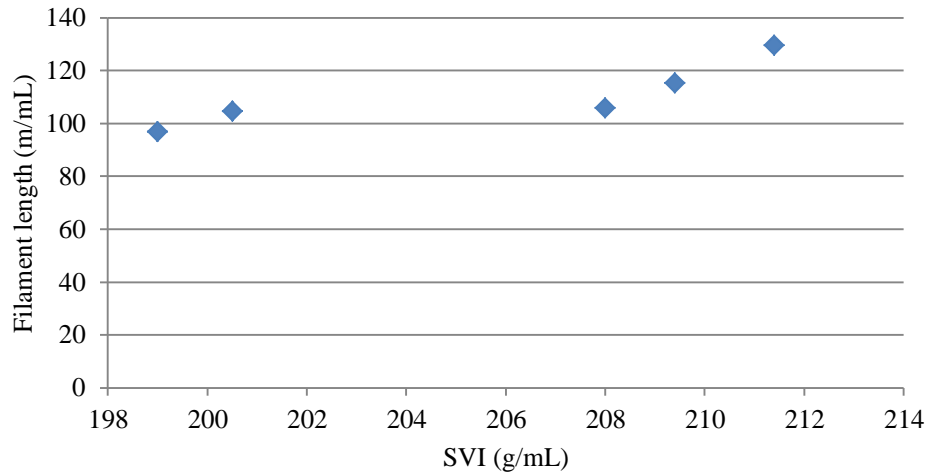

Figure 5.13: Relationship between filament length (m/mL) and SVI on the SBR run before being used for batch tests.

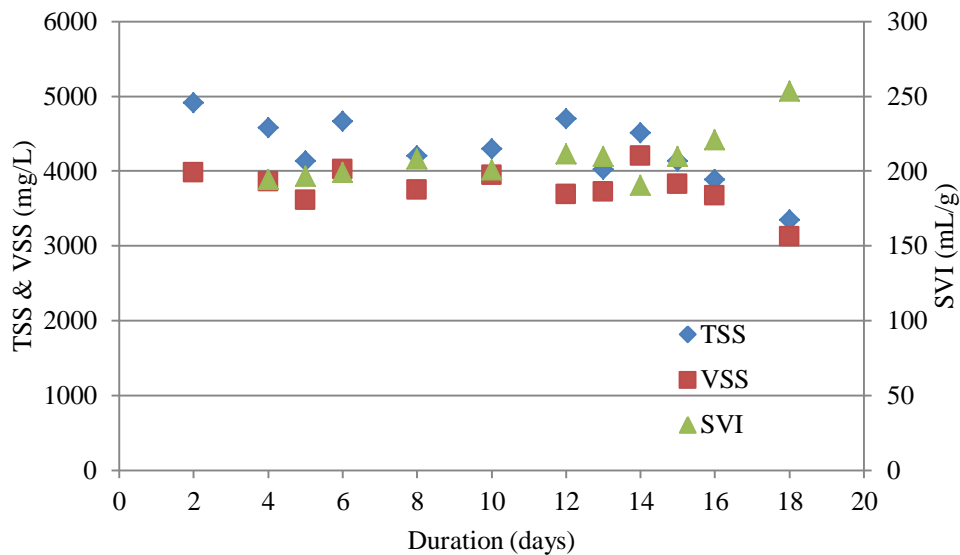

Figure 5.14: TSS, VSS and SVI on the SBR before the clay was sourced on day 18 for batch test.

The clay naturally had a pronounced effect on the ratio of VSS:TSS, ranging between 0.44-0.51 on the clay treatment and between 0.91-0.99 on the blank treatment. The variation in

amongst replicates is likely from a sampling error when taking samples for TSS and VSS (Table 5.8).

Table 5.8: Ratio of VSS:TSS in blank and clay treatments over the 5 day batch test.

	Blank			Clay		
	B (1)	B (2)	B (3)	C (1)	C (2)	C (3)
Day 1	0.93	0.97	0.94	0.5	0.48	0.44
Day 2	0.99	0.95	0.94	0.45	0.47	0.45
Day 3	0.99	0.96	0.94	0.47	0.48	0.47
Day 4	0.96	0.91	0.94	0.48	0.48	0.47
Day 5	0.96	0.95	0.95	0.51	0.48	0.51

Setting data (in the form of modified SVI), and filament length were analysed separately using a repeated measures mixed model ANOVA, in order to detect if there was a difference between the blank and the clay treatment and also if there was a change in parameters over 5 days (Section 4.4.2.5).

Changes in the modified SVI were insignificant across days 1, 3 and 5 ($P=0.335$ in a Pillai's Trace Multivariate test). Therefore there was no effect of either treatment on modified SVI over time (Fig. 5.15).

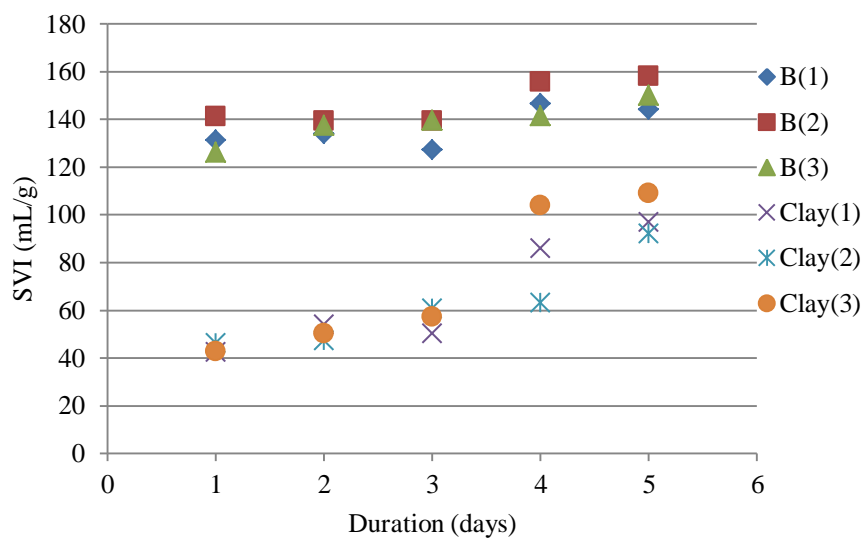

Figure 5.15: SVI over the 5 day batch test with blank and clay (5.0 g/L) treatments.

There was however a significant difference between the modified SVI in the two treatments (type III sum of squares effect ; $P < 0.001$). From Figure 5.15 it is clear that the clay produced lower modified SVI values from the blank settling values. It can be concluded that in this situation clay has a increases physical settling.

Like the modified SVI, there was no significant change in filament length over time (Pillai's Trace Multivariate test $P = 0.260$), indicating the treatment (blank or clay), did not have an effect over time. However there was a significant difference between the two treatments (Type III Sum of squares value of 0.028). From Table 5.8, it appears that overall the clay test had a higher filament length than the blank treatment and the hypothesis was rejected.

This clay settling test exhibited an increase results in physical settling but also an increase in filament length. The results will be discussed further below.

Table 5.9: Average filament length (m/mL) on each of the three replicates in each treatment on day 1, 3 and 5.

	Day1	Day3	Day5
Blank	98.5	102.8	103.2
	88.6	112.4	88
	90.1	129.6	92.2
Clay	100	92	128.8
	111.1	114.6	110.1
	87.7	108.3	145.9

5.5.3 Discussion of batch test results

The positive effect clay had on settling in the secondary batch test is complementary to the findings in the preliminary batch tests (Section 5.5.1, Fig. 5.11 & 5.12). Despite this, no positive effect on filament length was observed. This indicates that adding clay to a system

after it is bulking may mask the bulking problem by improving settling, while not fixing the problem microbiologically.

The non-significant change in modified SVI and filament length over time shows that both treatments were kept relatively stable across the testing period. From Figure 5.13, there appears to be a slight increase in modified SVI over time and especially in the clay treatment. This was statistically insignificant, but it is possible that with a larger sample size and/or longer duration a significant difference may develop over time.

There are several other factors that may affect the results. One major factor is the biomass used. It is possible the quality of the sludge was too poor to produce a significant microbiological result. Bulking or other sludge biomass imbalances may be too severe to be reversed. That is, there may be a critical point where clay addition (or other intervention) is ineffective at controlling bulking. This potential critical point may be related to the ratio of VSS:TSS, (Section 5.3.5), which on the sludge which was used for these tests was 0.94 (ranging from 0.91-0.99 on the batch tests). Ratio of VSS:TSS may be related to reactor deterioration as a certain amount of grit or other material may be required to help healthy floc formation. It is possible the sludge can tolerate a decrease in non-VSS up to a certain level and once it passes that level will start to deteriorate.

Another possibility is the high clay concentration of 5.0 g/L may have swamped the system with too many clay particles, resulting in enhanced physical settling but not significantly decreasing filament length. The SWW used to feed the batch tests was designed to induce bulking, and a potential significant effect of clay on reducing filament length may have been counteracted by the SWW.

In addition, the operational parameters may not have been accurate enough at mimicking a full scale WWTP. In the batch tests there was only 800 mL of sludge in each treatment (Section 4.6.1). Despite having reasonable pH and COD levels when compared to the SBRs (Table 5.6-5.7, Section 5.5.2.1), the conditions would still not be the same as those in a full scale WWTP. The stirring fleas used may have been too vigorous and even caused floc-shearing. The magnetic stirrers also produced a small amount of heat during operation and slightly warmed the sludge samples. The temperature was not recorded, but should have been investigated as it may have had an effect on sludge health. Any one of these factors or any combination could have affected the results. Another difference in operation is that batch tests were left settling over night (Section 4.4.1), which would not be representative of what happens in a WWTP. It is unknown what effect this may have on the sludge health but it is possible this may have created favourable conditions for filamentous bacterial growth.

5.6 Clay tests in the SBRs

A final run consisted of clay being added to one SBR while the other was left as a control. The clay was added when the SBRs reached a ratio of VSS:TSS of 0.84 (with an initial start-up ratio of 0.74), on day 11 of operation, and was maintained at this ratio by regular addition of clay (Section 4.5). This ratio of VSS:TSS was maintained because if it had risen higher there might have been reactor failure as indicated in previous runs when it approached 1.0 (Section 5.3.5). The ratio of 0.84 allowed some change from the starting ratio while still being a comfortable distance from 1.00.

Mixing together of the biomass in the SBRs, on day 10 (Section 4.5), along with the identical operating conditions in each SBR, aimed to keep all other conditions (excluding clay addition), as similar as possible. The results from this run need to be interpreted with caution as there is only one replicate of each treatment so statistical analysis cannot be performed.

Both SBRs appeared to follow the same trend observed across all reactor runs (Fig. 5.16 & 5.17); where the solids decreased over time while the SVI increased over time (Section 5.3.5). However there appears to be slight differences between the two SBRs. From visual observation, it appears the reactor with clay added had a more gradual increase in SVI as opposed to the reactor without clay, where the SVI seemed to increase more rapidly.

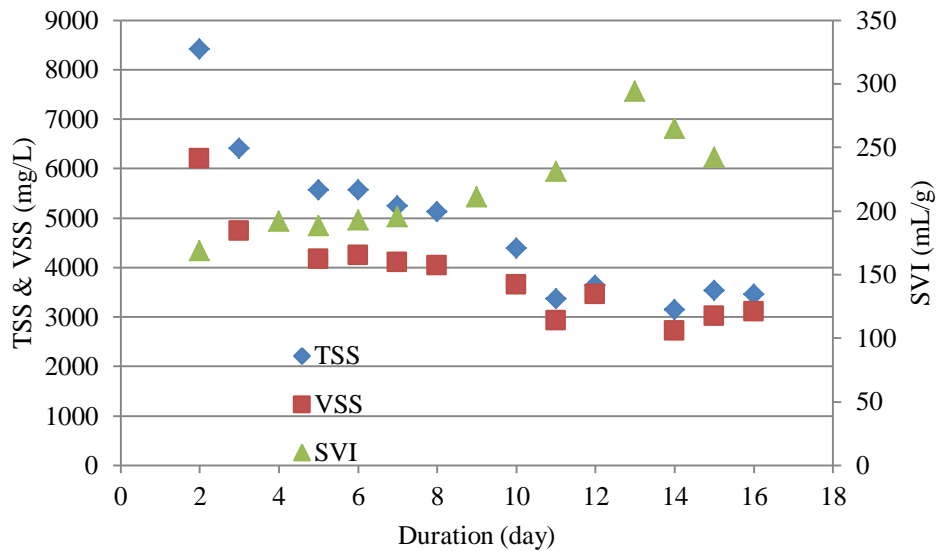

Figure 5.16: TSS, VSS and SVI over time on SBR 1, no clay added.

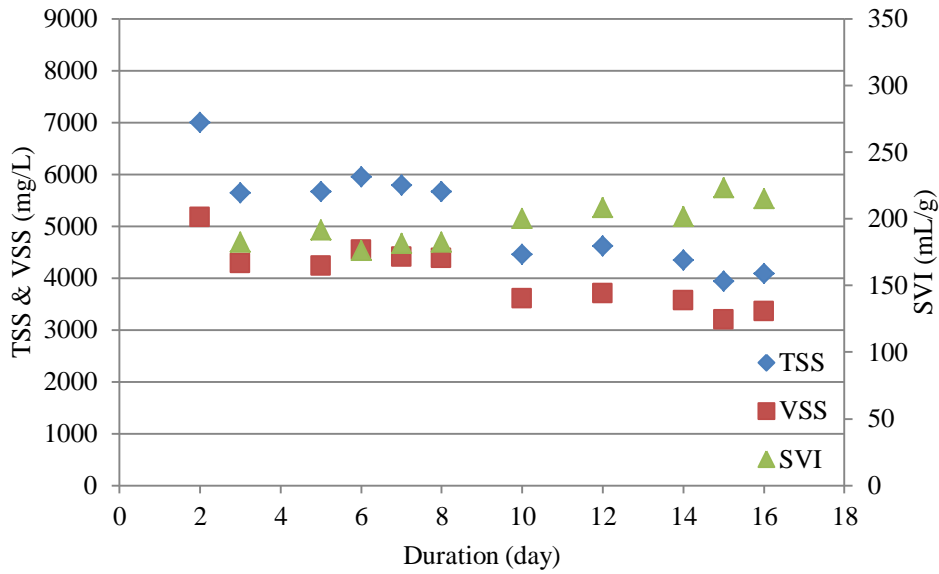

Figure 5.17: TSS, VSS and SVI over time on SBR 2, clay added.

Because the SBRs were mixed together on day 10, a correlation between filament length and SVI yielded no strong result since mixing changed the composition of the sludge. There were only three other points where the SVI and filament length were measured together after clay was added to the mixed reactors (in SBR 2). As such, there are too few data points to produce an accurate correlation. Figures 5.18 & 5.19 show SVI and filament length over the duration of each run. The SBRs were not run for longer as the sludge in SBR 1 appeared to be watery and was starting to deteriorate.

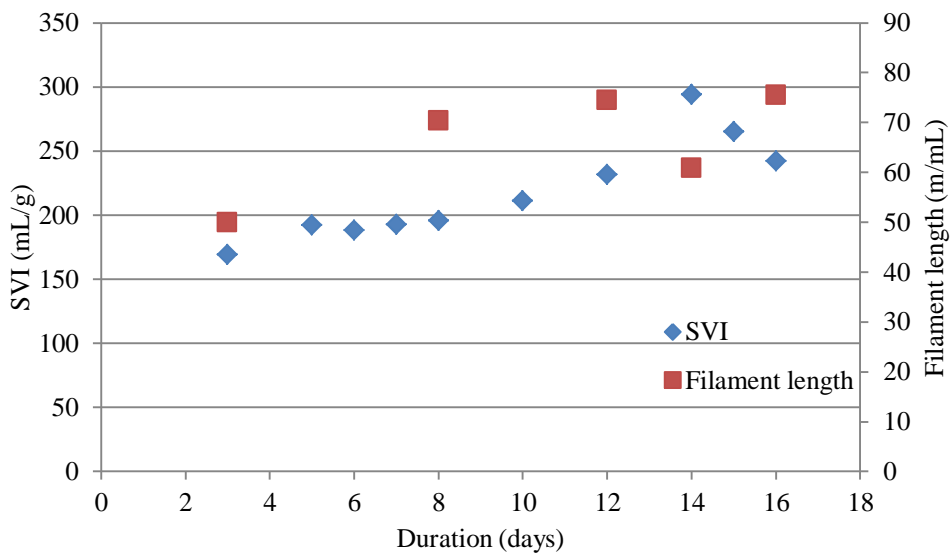

Figure 5.18: SVI and filament length over time. SBR 1, no clay added.

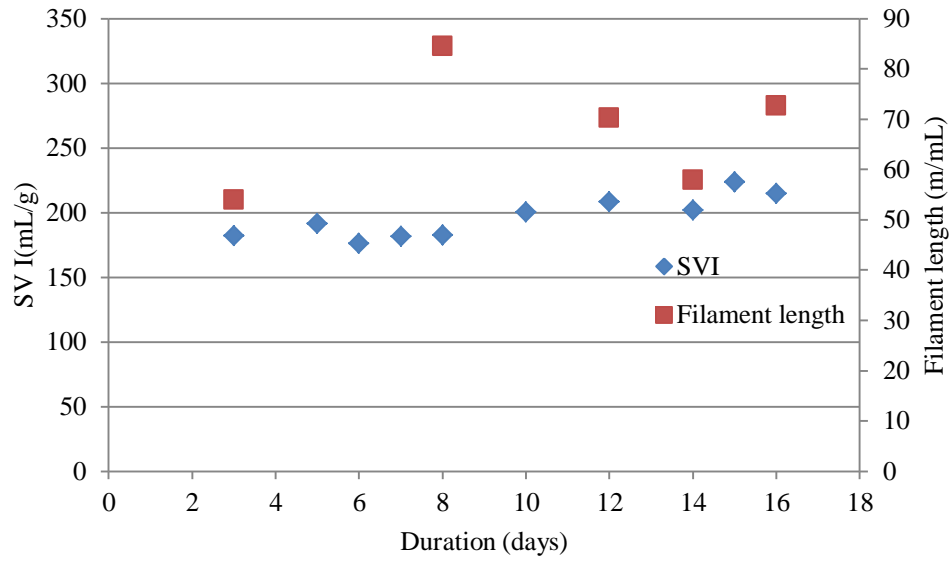

Figure 5.19: SVI and filament length over time. SBR 2, clay added.

6.0 Conclusions and recommendations

This preliminary investigation into clay as an agent to remediate filamentous bulking has resulted in the following conclusions:

- At high concentrations (5.0 g/L), the clay produces a positive effect on settling (Section 5.5.1 & 5.5.2), while not reducing filament length (Section 5.5.2). Thus it is suggested that the clay improves settling purely by physically weighting down the sludge
- A 5.0 g/L clay concentration was chosen to detect an effect on filament length. However, it would not be feasible to add 5.0 g/L of clay suspension to a full-scale WWTP that was experiencing bulking. Despite clay addition enhancing settling in batch tests (Section 5.5) it may be a short lived improvement, as the tests were run for only 5 days. Because there is no reduction in filament length from the clay, it is likely only a matter of time until settling would deteriorate.
- Over an extended period of time, clay loss would occur through sampling and decanting, and the physical settling from clay would be reduced. Therefore if clay is to be used as a settling enhancer in bulking episodes, other methods may need to be employed to correct what is happening to microbial constituents of the sludge.
- The investigation of general SBR functioning yielded interesting trends in regards to the SWW, ratio of VSS:TSS and sludge deterioration (elevated SVI and decrease in solids). This indicates that the use of SWW could be a major influence on SBR function (Section 5.3.5). Maintaining the ratio of VSS:TSS at a certain level (such as the ratio of the original sludge sample) may help prevent bulking in SWW treatments.

- The introduction of clay in the SBRs yielded disappointing results due to rapid sludge deterioration (Section 5.6). Also due to time constraints, the run was not of sufficient duration to obtain conclusive data.
- In summary, in relation to the VSS:TSS ratio theory, there may not be a place for clay addition as a bulking preventative agent in large scale WWTPs as there is a constant introduction of non-VSS entering the system daily.

The following recommendations arise from this research:

- Only filament length was investigated as a microbiological parameter, using bright field light microscopy (Section 4.3.1). Much current research into filamentous bulking is now however using fluorescent genetic probes and optical monitoring techniques which have the ability to look at other sludge microbes as well as species causing bulking (Section 2.5.1.2). Further research into the effect of clay addition on filamentous (and other types of bulking) as well as overall sludge community structure should use these techniques.
- Despite no decrease in filament length with the clay treatment (Section 5.5.2), there should be more investigation into a range of clay additions that would be feasible in full scale WWTPs. Only one trial was completed at 5.0 g/L and many other factors could have affected total length of microbial filaments (Section 5.5.3).
- The impact of clay on settling and microbiology should be investigated in SBR SWW trials and related back to the ratio of VSS:TSS to see if there is a link between reactor deterioration and VSS:TSS ratio. Different ratios should also be investigated. In adding clay to one SBR (Section 5.6), the ratio was maintained at around 0.82-0.84 when the starting ratio was 0.74. It would be interesting to investigate SBRs fed with SWW at their initial sludge start up ratio without allowing the ratio to drop at all,

while comparing them to SBRs with no clay. This may have applications in the use of grit traps in full scale WWTPs as it may be beneficial to have a certain amount of non-volatile suspended solids in the wastewater for sludge health.

7.0 REFERENCES

- Agridiotis, V., Forster, C. F., & Carliell-Marquet, C. (2007). Addition of Al and Fe salts during treatment of paper mill effluents to improve activated sludge settlement characteristics. *Bioresource Technology* , 98, 2926-2934.
- Amaral, A. L., & Ferreira, E. C. (2005). Activated sludge monitoring of a wastewater treatment plant using image analysis and partial least squares regression. *Analytica Chimica Acta* , 544, 246-253.
- Amaral, A. L., Mesquita, D. P., & Ferreira, E. C. (2013). Automatic identification of activated sludge disturbances and assessment of operational parameters. *Chemosphere* , 91, 705-710.
- Andreasen, K., & Nielsen, P. H. (2000). Growth of *Microthrix parvicella* in nutrient removal activated sludge plants: studies of in situ physiology. *Water Research* , 34:5, 1559-1569.
- Caravelli, A., Giannuzzi, L., & Zaritzky, N. (2006). Effect of ozone on filamentous bulking in a laboratory scale sludge reactor using respirometry and INT-dehydrogenase activity. *Journal of Environmental Engineering* , 132:9, 1001-1010.
- Caravelli, A.; Contreras, E. M.; et al. (2003). Modeling of chlorine effect on floc forming and filamentous micro-organisms of activated sludges. *Water Research* , 37, 2097-2105.
- Clark, J. V. (1977). *Water supply and pollution control, 3rd edition*. Harper and Row.
- Chiesa, S. C., Irvine, R. L., & Manning Jr, J. F. (1985). Feast/famine growth environments and activated sludge population selection. *Biotechnology and Bioengineering* , 27:5, 562-568.
- Chudoba, J., Grau, P., & Ottova, V. (1973). Control of activated-sludge filamentous bulking-II. Selections of microorganisms by means of a selector. *Water Research* , 7, 1389-1406.
- Chudoba, J.; Cech, J. S.; et al. (1985). Control of activated sludge filamentous bulking Experimental verification of a kinetic selection theory. *Water Research* , 19:2, 191-196.
- Costa, J. C.; Mesquita, D. P.; et al. (2013). Quantitative image analysis for the characterization of microbial aggregates in biological wastewater treatment: a review. *Environmental Science and Pollution Research* , 20, 5887-5912.
- da Motta, M., Pons, M. N., & Roche, N. (2002). Study of filamentous bacteria by image analysis and relation with settleability. *Water Science and Technology* , 46:1-2, 363-369.
- Dick, R. I., & Vesilind, P. A. (1969). The sludge volume index: what is it? *Water Pollution and Control Federation* , 41:7, 1285-1291.
- Eaton, A., & G. A; et al. (2005). *Standard methods for the examination of water & wastewater*. American Public Health Association Publications.

Eikelboom, D. H. (1977). Identification of filamentous organisms in bulking activated sludge. *Progress in Water Technology* , 8, 153-162.

Eikelboom, D. H., & Groovestien, J. (1988). Control of bulking in a full scale plant by addition of talc (PE8418). *Water Science and Technology* , 37, 297-301.

Englert, D.; Zubrod, J. P.; et al. (2013). Effects of municipal wastewater on aquatic ecosystem structure and function in the receiving stream. *Science of the Total Environment* , 454-455, 401-410.

Ferreira, V.; Martins, C.; et al. (2014). Use of an aerobic selector to overcome filamentous bulking in an activated sludge wastewater treatment plant. *Environmental Technology* , 35:12, 1525-1531.

Gray, D. M. D.; De Lange, V. P.; et al. (2010). Investigating the fundamental basis for selectors to improve activated sludge setting. *Water Environment Research* , 82:6, 541-555.

Gulez, G., & de los Reyes III, F. L. (2009). Multiple approaches to assess filamentous growth in activated sludge under different carbon source conditions. *Journal of Applied Microbiology* , 106, 682-691.

Guo, J., Peng, Y.; et al. (2012a). Control filamentous bulking caused by chlorine-resistant Type 021N bacteria through adding a biocide CTAB. *Water Research* , 46(19) 6531-6542.

Guo, J.; Peng, Y.; et al. (2012b). Stable limited filamentous bulking through keeping the competition between floc-formers and filaments in balance. *Bioresource Technology* , 103, 7-15.

Gupta, V. K.; Ali, I.; et al. (2012). Chemical treatment technologies for waste-water recycling. *RCS Advances* , 2, 6380-6388.

Henry, M., & Debarbieux, L. (2012). Tools from viruses: bacteriophage success and beyond. *Virology* , 434, 151-161.

Hu, B.; Qi, R.; et al. (2013). Dynamics of the microfauna community in a full-scale municipal wastewater treatment plant experiencing sludge bulking. *European Journal of Protistology* , 49, 491-499.

Jassby, D., Xiao, Y., & Schuler, A. (2014). Biomass density and filament length synergistically affect activated sludge settling: Systematic quantification and modelling. *Water Research* , 48, 457-465.

Jenkins, D., Richard, M. G., & Daigger, G. (2003). *Manual of the causes and control of activated sludge bulking, foaming and other solids separation problems*. Boca Raton, FL: Lewis Publishing.

Jenkins, D., Richard, M. G., & Daigger, G. T. (1984). *Manual on the causes and control of activated sludge bulking and foaming*. Pretoria: Water Research Commission.

- Jenne, R.; Banadda, E. N.; et al. (2007). Detection of filamentous bulking problems: developing an image analysis system for sludge composition monitoring. *Microscopy and Microanalysis* , 13, 36-41.
- Jin, B., Wilen, B., & Lant, P. (2003). A comprehensive insight into floc characteristics and their impact on compressibility and settleability of activated sludge. *Chemical Engineering Journal* , 95, 221-234.
- Koivuranta, E.; Keskitalo, J.; et al. (2014). A comparison between floc morphology and the effluent clarity at a full-scale activated sludge plant using optical monitoring. *Environmental Technology* , 35:13, 1605-1610.
- Koivuranta, E.; Keskitalo, J.; et al. (2013). Optical monitoring of activated sludge flocs in bulking and non-bulking conditions. *Environmental Technology* , 34:5, 679-686.
- Kotay, S. M.; Datta, T.; et al. (2011). Biocontrol of biomass bulking caused by *Haliscomenobacter hydrosis* using a newly isolated lytic bacteriophage. *Water Research* , 45, 694-704.
- Lau, A. O., Strom, P. F., & Jenkins, D. (1984). Growth kinetics of *Sphaerotilus natans* and a floc former in pure and dual continuous culture. *Water Pollution Control Federation* , 56:1, 41-51.
- Lou, I. C.; de los Reyes III, F. L.;. (2005). Integrating decay, storage, kinetic selection, and filamentous backbone factors in a bacterial competition model. *Water Environment Research* , 77:3, 287-296.
- Madoni, P. (1994). A sludge biotic index (SBI) for the evaluation of the biological performance of activated sludge plants based on microfauna analysis. *Water Research* , 28:1, 67-75.
- Martins, A. M. P.; Pagilla, K.; et al. (2004). Filamentous bulking sludge - a critical review. *Water Research* , 38, 793-817.
- Martins, A. M., Heijnen, J. J., & van Loosdrecht, M. C. (2003). Effect of dissolved oxygen concentration of sludge settleability. *Applied Microbiology and Biotechnology* , 62, 586-593.
- Martins, A. M., Karahan, O., & van Loosdrecht, M. C. (2011). Effect of polymeric substrate on sludge settleability. *Water Research* , 45, 263-273.
- Mesquita, D. P., Amaral, A. L., & Ferreira, E. C. (2011). Identifying different types of bulking in an activated sludge system through quantitative image analysis. *Chemosphere* , 85, 643-652.
- Mesquita, D. P.; Dias, O.; et al. (2009). Correlation between sludge settling ability and image analysis information using partial least squares. *Analytica Chimica Acta* , 642, 94-100.
- Mohlman, F. W. (1934). The sludge index. *Sewage Works Journal* , 6:1, 119-121.

- Nedoma, J.; Vrba, J.; et al. (2001). Quantification of pelagic filamentous microorganisms in aquatic environments using the line-intercept method. *FEMS Microbiology Ecology*, 38, 81-85.
- Nielsen, P. H.; Kragelund, C.; et al. (2009). Identity and ecophysiology of filamentous bacteria in activated sludge. *FEMS Microbiology Reviews*, 33, 969-998.
- Novak, L.; Larrea, L.; et al. (1993). Non-filamentous activated sludge bulking in a laboratory scale system. *Water Research*, 27:8, 1339-1346.
- Park, C.; Fang, Y.; et al. (2010). Effects of floc aluminum on activated sludge characteristics and removal of 17- α -ethinylestradiol in wastewater systems. *Water Research*, 44, 1335-1340.
- Piirtola, L., Hultman, B., & Lowen, M. (1999). Activated sludge ballasting in pilot plant operation. *Water Research*, 33:13, 3026-3032.
- Piirtola, L.; Hultman, B.; et al. (1999). Activated sludge ballasting in batch tests. *Water Research*, 33:8, 1799-1804.
- Pipes, W. O. (1967). Bulking of activated sludge. *Advances in Applied Microbiology*, 9, 185-234.
- Richard, M. (2003). Activated sludge microbiology problems and their control. *USEPA National Operator Trainers Conference*, (pp. 1-21). Buffalo, NY.
- Saayman, G. B., Schutte, C. F., & van Leeuwen, J. (1998). Chemical control of filamentous sludge bulking in a full-scale biological removal activated sludge plant. *Ozone: Science and Engineering: The Journal of the International Ozone Association*, 20:1, 1-15.
- Schmid, M.; Thill, A.; et al. (2003). Characterization of activated sludge flocs by confocal laser scanning microscopy and image analysis. *Water Research*, 37, 2043-2052.
- Schuler, A. J., & Jassby, D. (2007). Filament content threshold for activated sludge bulking: artifact or reality? *Water Research*, 41, 4349-4356.
- Sezgin, M., Jenkins, D., & Parker, D. S. (1978). A unified theory of filamentous activated sludge bulking. *Water Pollution Control Federation*, 50:2, 362-381.
- Smets, I. Y.; Banadda, E. N.; et al. (2006). Dynamic modeling of filamentous bulking in lab-scale activated sludge processes. *Journal of Process Control*, 16, 313-319.
- Soddell, J. A., & Seviour, R. J. (1990). Microbiology of foaming in activated sludge plants. *Journal of Applied Bacteriology*, 69, 145-176.
- Strakova, L.; Kopp, R.; et al. (2013). Dynamics of the cyanobacterial water bloom with focus to *Microcystis* and its relationship with environmental factors in Brno Reservoir. *Acta Universitatis Agriculturae et Silviculturae Mendelianae Brunensis*, 154:5, 1383-1390.

- Tian, W-D.; Li, W-G.; et al. (2011). Limited filamentous bulking in order to enhance integrated nutrient removal and effluent quality. *Water Research* , 45, 4877-4884.
- Van den Eynde, E.; Geerts, J.; et al. (1983). Influence of the feeding pattern on the glucose metabolism of *Arthrobacter* sp. and *Sphaerotilus natans*, growing in chemostat culture, simulating activated sludge bulking. *European Journal of Applied Microbiology and Biotechnology* , 17, 35-43.
- Varela, A. R., & Manaia, C. M. (2013). Human health implications of clinically relevant bacteria in wastewater habitats. *Environmental Science and Pollution Research* , 20, 3550-3569.
- Wagner, M., & Loy, A. (2002). Bacterial community composition and function in sewage treatment systems. *Current Opinion in Biotechnology* , 13:3, 218-227.
- Wagner, M.; Amann, R.; et al. (1993). Probing activated sludge with oligonucleotides specific for proteobacteria: inadequacy of culture-dependent methods for describing microbial community structure. *Applied and Environmental Microbiology* , 59:5, 1520-1525.
- Wagner, M.; Loy, A.; et al. (2002). Microbial community composition and function in wastewater treatment plants. *Applied and Environmental Microbiology* , 81:1-4, 665-680.
- Wang, Z.; Wang, P.; et al. (2010). Effective control of membrane fouling by filamentous bacteria in a submerged membrane bioreactor. *Chemical Engineering Journal* , 158, 608-615.
- Wei, D., Tan, Z., & Du, Y. (2012). Toxicity-based assessment of the treatment performance of wastewater treatment and reclamation processes. *Journal of Environmental Sciences* , 24:6, 969-978.
- Wilen, B., Jin, B., & Lant, P. (2003). Impacts of structural characteristics on activated sludge floc stability. *Water Research* , 37, 3632-3645.
- Wilen, B.; Onuki, M.; et al. (2008). Microbial community structure in activated sludge floc analysed by fluorescence in situ hybridization and its relation to floc stability. *Water Research* , 42, 2300-2308.
- Yang, X.; Peng, Y.; et al. (2013). Nutrient removal performance and microbial community structure in an EBPR system under the limited filamentous bulking state. *Bioresource Technology* , 144, 86-93.
- Ziegler, M., Lange, M., & Dott, W. (1990). Isolation and morphological and cytological characterization of filamentous bacteria from bulking sludge. *Water Research* , 24, 1437-1451.