

UNIVERSITY OF CANTERBURY

Tongan Schools go Solar;

8 kW Photovoltaic System Design & Installation by University of Canterbury Students in Five Tongan Schools

EEA Conference & Exhibition 2013, 19 - 21 June, Auckland

Shreejan Pandey*¹, Pat Bodger², Vladimir Abelentsev³, Andrew Laphorn²

¹ Electric Power Engineering Centre, University of Canterbury

² Electrical and Computer Engineering, University of Canterbury

³ Meridian Energy Limited

* Presenting

19/04/2013

1 INTRODUCTION

Electricity is a fundamental source of social well-being and economic activity in modern society. In the case of Pacific Island nations like Tonga, energy plays a noticeable role and affects all businesses and every household by either enhancing or degrading the livelihood of its people.

The commissioning of Meridian Energy Ltd.'s 1 MW Mamma Mai photovoltaic (PV) solar farm in 2012 has reduced the grid make up of diesel fuelled generation capacity from 100% to approximately 93 %. The cost of electricity in Tonga is in part, reliant on diesel price that tracks the cost of crude oil. In late 2008, the cost of electricity exceeded TOP 1.00 /kWh (approximately NZ \$0.70/kWh). Determined to reduce Tonga's vulnerability to oil price shocks, the Tongan Government, in 2009, approved a policy to supply 50% of Tonga's energy through renewable resources.

The drive towards renewable electricity in the Pacific Island countries is welcomed and supported by donor agencies including New Zealand's Ministry of Foreign Affairs and Trade Aid Programme. Renewable energy was first identified as a key support focus for the Pacific in 2010 in an effort to reduce Pacific Island nations' vulnerability to high and fluctuating price of diesel, used as the main source of fuel for generation [1]. New Zealand and the European Union, co-hosts of the Pacific Energy Summit 2013, in March 2013 announced a \$255 million grant funding and \$380 million in concessional loans to support over 40 proposed projects. The support comes from several donor partners including \$65 million in funding from New Zealand to advance and realize renewable energy projects across the Pacific [2].

During June and July 2012, a group of volunteers from New Zealand worked in partnership with the Kingdom of Tonga Ministry of Education and Training (MET), Tonga Power Ltd. (TPL) and JH Electrical Contractor and Supplies (JH), to install solar PV power systems of 8 kWp in five Tongan high schools. The installations were a part of the Solar PV and ICT Pilot Programme for Tongan schools coordinated by EcoCARE Pacific Trust (EcoCARE) in partnership with MET [3]. EcoCARE engaged University of Canterbury (UC) staff, student and alumni volunteers for the design, procurement and installation purposes. Engaging volunteers via UC provided capable and interested individuals to partially satisfy their academic, practical and personal interests while carrying out the works required for the project. The project was initially conceptualised in 2009 by EcoCARE with the intention of installing solar power systems in all Tongan high schools to reduce the burden of electricity related costs in schools and to enable greater use of information and communication technologies (ICTs). The project was funded by the New Zealand Ministry of Foreign Affairs and Trade and administrated by Rotary New Zealand World Community Services Ltd. (Rotary).

2 PROJECT BACKGROUND

2.1 NEEDS ASSESSMENT

The project proposal submitted by Rotary and EcoCARE to MFAT highlights that Tongan schools are often closed numerous times each year because they don't have the required funds to pay for the electricity needed to pump water for drinking and sanitation purposes. The proposal states that the cheap reliable electricity provided by the pilot project would enable the five schools and their communities to benefit from the use of Information and Communication

Technologies (ICTs). The proposal promises a significant educational component as part of the pilot project to test the effectiveness of enabling students to use technology as an educational resource. The proposal also states that savings in energy cost, estimated to be “between TOP\$11.25 million and TOP\$15million” over the lifetime of the solar panels, could be spent in other areas of education, allowing some flexibility to the annual power budget of TOP\$750,000.

No formal needs assessments in the form of recipient community surveys or other methods were carried out to determine the worth for the proposed activity. The actual estimated energy cost savings in the proposal is also questionable given that there was no agreement on metering and pricing methodology for the generated electricity between any of the multi-party stakeholders.

2.2 SELECTION OF FIVE SCHOOLS

EcoCARE advise that the five schools which ended up receiving the 8kWp PV systems were selected by the MET as part of a proposed national roll-out project in Tonga. The selection of schools were based on a criteria from EcoCARE to select as diverse a group of schools as possible whilst being able to prove the capacity of EcoCARE to deliver the project as described in the project proposal. The donor, MFAT, recommended the pilot project of 5 schools to be carried out in schools located on the main island of Tongatapu. Concentrating on the comparatively well-resourced island of Tongatapu with easy access to infrastructure during the pilot stage of the project had advantages. Project partners would familiarize themselves with challenges and lessons that could be applied for works in the more remote and challenging islands at a later stage. The geographic locations of the five schools in Tongatapu are shown in Figure 1.

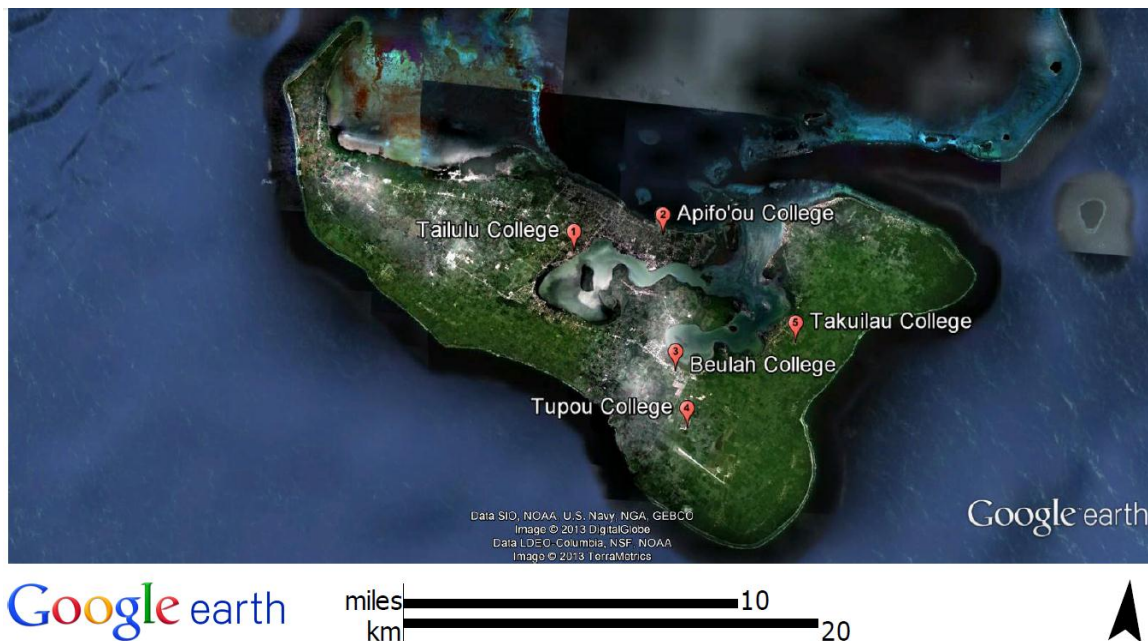

FIGURE 1: ISLAND OF TONGATAPU AND LOCATION OF FIVE MET SELECTED HIGH SCHOOLS TO RECEIVE SOLAR PV ENERGY SYSTEM INSTALLATIONS

2.3 STANDARD DESIGN OF INSTALLATIONS & FOCUS ON PV SYSTEMS

EcoCARE advised at all times that each installation needed to meet the 8kWp criteria. From a design and installation point of view, a standard design could be replicated and installed in suitable schools. The poor condition of existing wiring in some schools was identified in the feasibility assessment carried out in October 2011 [4]. However, the project budget was granted for the purposes of capital purchase and installation of the PV systems and did not allow for refurbishments of existing infrastructure in schools.

3 PROJECT DESIGN

3.1 ENVIRONMENTAL REQUIREMENTS

The harsh coastal salt-mist corrosion and cyclone prone environmental conditions of Tongatapu were considered during the design and selection process of procured equipment and materials. In particular, PV panels and mounting rails were required to withstand salt sprays, and high wind speeds of approximately up to 164 km /hr [5].

3.2 APPLICABLE TECHNICAL STANDARDS

The grid connected PV power generation system was designed to meet applicable New Zealand standards for similar systems. International quality management, environmental management and technical standard certification determined the specification of PV modules and inverters.

3.3 SYSTEM DESIGNS

This “pilot project” was anticipated for future expansion with the possibility of all Tongan high schools receiving solar PV energy systems. Two separate “one size fits all type” systems were designed and implemented in parallel, in order to “test out” a more successful design from the perspective of user friendly maintenance and manufacturer/supplier service support. A third inverter, SMA STP 8000TL was also considered for implementation in one of the schools due to SMA’s high quality and user friendly reputation in the industry. However, due to the high global demand for SMA inverters in 2012, the supplier was unable to deliver the order and Enasolar single phase inverters were air freighted just in time for installation.

Suntech STP 250 mono crystalline PV modules were selected for all designs over a number of alternative options presented in Table I. Five shortlisted suppliers from New Zealand and Australia were invited to submit their quotes. Suntech Australia was selected due to the quality of their service,

TABLE I: PV MODULE SELECTION CRITERIA

PV Module	Mature Technology & Brand	Least No of Panels/School	Cost Efficiency / Wp	Relevant Standards & Tests	Recognized by Experts
BP solar: BP4190T	✓				
Suntech: STP250	✓	✓	✓	✓	✓
Suntech: STP 190	✓				✓
Kyocera: KD215GH-2PU	✓			✓	✓
CNPV: 240P			✓	✓	

product and negotiated competitive pricing.

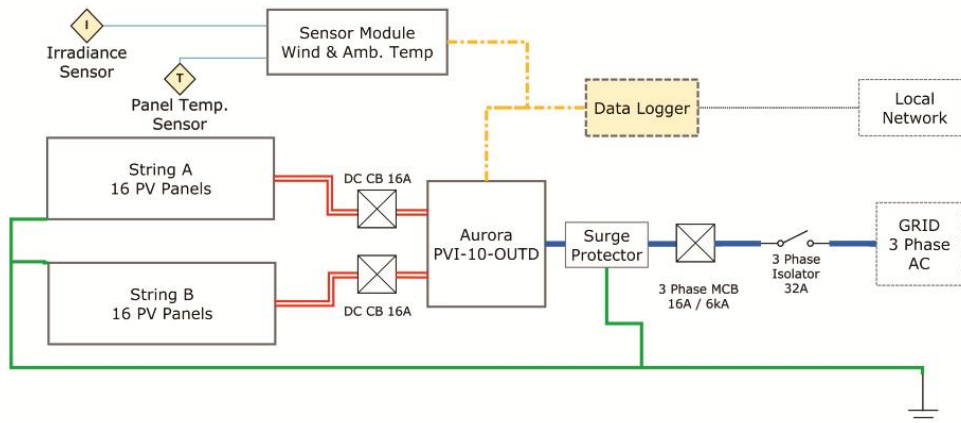

FIGURE 2: DESIGN A SCHEMATIC INSTALLED IN TAKUILAU COLLEGE & BEULAH COLLEGE.

System Design A; Suntech PV modules with Power One Aurora inverter

Solar cells have a complex relationship between solar irradiation, temperature and total resistance that produces non-linear output efficiency. Inverters use a maximum power point tracking (MPPT) system to get the maximum possible power from the PV panels. The MPPT samples the output of cells and applies the required resistance (load) to obtain maximum power for any given environmental condition. Aurora provides two independent MPPT systems.

An array of 16 Suntech STP 250 panels were connected in series and terminated to each MPPT PV input with a standard test condition (STC) of 491.2 V DC and a short circuit current of 8.63 A. The PV array's electrical parameters were matched as best as possible to the optimum inverter efficiency requirement. The Aurora inverter is expected to perform at an efficiency of approximately 97.5% and provide a maximum PV power generation of 7.8 kW under the STC. The 3 phase AC output from the Aurora inverter was connected to a 3 phase protection system and terminated to the 3 phase 415 V, AC mains supplied by TPL. The PV array frames were earthed to provide equipotential bonding and terminated to the existing switchboard's earth link in each case.

Compared to the Enasolar inverters, Power One's 10 kW 3 phase Aurora inverter offered a very competitive rate with up to \$239 / kWp in savings with data logging & remote retrieval systems and up to \$462/kWp in savings without data loggers and sensors. Compared to the Enasolar systems, additional nominal cost savings can be made as the Aurora requires fewer components in the number of PV arrays and AC protection equipment. Such price differences are worth considering if all Tongan high schools are to receive PV systems. The Aurora inverter is armed with relevant AS/NZS, IEC, ISO and a range of international certifications and Power One does not attempt to reduce quality over cost. The data logger / communication system is not very user friendly and there are some concerns over the availability of reliable and on-going supplier/manufacture service to the operator.

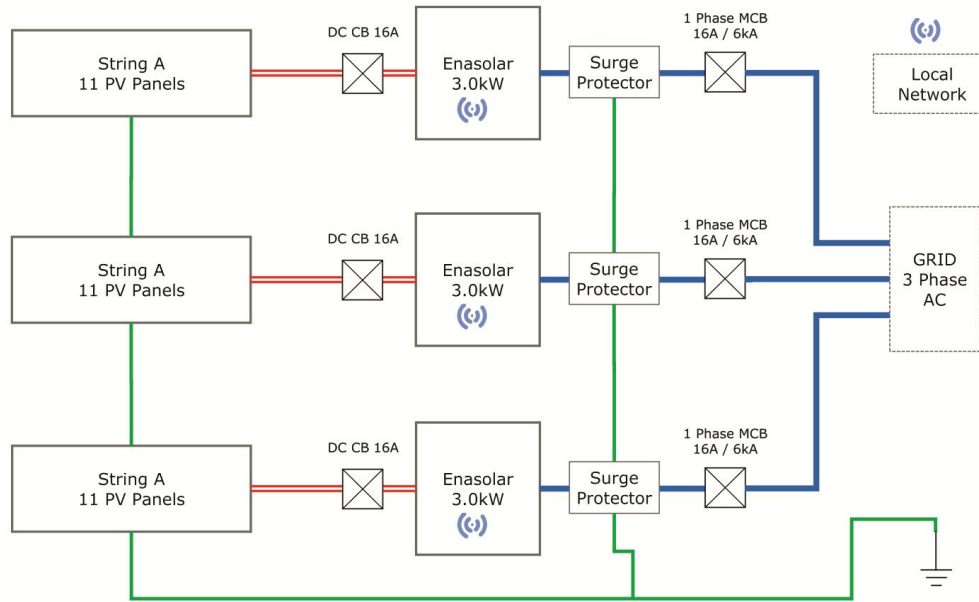

FIGURE 3 DESIGN B SCHEMATIC INSTALLED IN TUPOU COLLEGE, ‘APIFO’OU COLLEGE & TAILULU COLLEGE

Takuilau College and Beulah College received installations of this system. The Design A schematic is shown in Figure 2.

System Design B; Suntech PV modules with Enasolar inverter

A PV array of 11 Suntech STP 250 panels were connected in series and terminated to the MPPT input of a single phase 3 kW Enasolar inverter. The array would reach a maximum of 337.7 V with a short circuit current of 8.63 A under the STC. The PV array’s electrical parameters were within the inverter’s requirement. The Enasolar inverter is expected to perform at an efficiency greater than 96.5% and provide a maximum PV power generation of 2.65 kW under the STC. The single phase AC output from the Enasolar inverter was connected to a single phase protection system and terminated to one of the three phases of the 415 V AC mains supplied by TPL. Two more identical single phase Enasolar systems were terminated to the remaining two phases of the 415 V AC mains, supplying a combined maximum total power of 7.95 kW. All three PV array frames were earthed to provide equipotential bonding and terminated to the existing switchboard’s earth link. Tupou College, ‘Apifo’ou College and Tailulu College received installations of this system. The Design B schematic is shown in Figure 3

Compared to the Aurora inverters, Enasolar inverters are easy to install and come with a user friendly remote connection and data monitoring system. Excellent on-going support has been received to date. The New Zealand based design team and in country partner JH were trained in Christchurch by the manufacturer at no additional cost to install and configure the inverter to ensure user proficiency. The inverter meets relevant AS/NZS and a range of relevant international standards. The importance of user friendly design, on-going support and training directly from the manufacturer may add to the long term sustainability of the equipment. Such design and services are worth considering over price if all Tongan high schools, including those in remote islands, are to receive PV systems.

3.4 METERING

EDMI, a smart metering company operating in New Zealand, provided MK10A meters with Class 1 accuracy, capable of measuring bidirectional 3 element 4 quadrant energy values with an accuracy better than 1%. The MK10A meters logged salient information such as power quality indicators and events based on configured intervals, and allowed remote data retrieval via General Packet Radio Services (GPRS) radio transmission of small packets of data via cellular phone Subscriber Identification Module (SIM) cards. The in-kind sponsorship allowed EDM I an opportunity to enter the Pacific Islands' metering market.

TPL's existing meters were only capable of logging unidirectional energy flow and required a meter reader to manually read and log data on a monthly basis. In 2012, TPL had commenced investigating their smart metering option, and the opportunity to trial MK10A meters was timely.

The installed metering system for revenue and check purposes in schools was comprised of three meters. The existing TPL meters in schools (Meter A) measures TPL network export Wh values, the consumption of energy by the school. Meter A is read on a monthly basis and schools are charged the amount of consumption as per the normal TPL billing procedure.

A new meter (Meter B) measures the TPL network import Wh values, the generation from solar PV system injected into the TPL network. Meter B is read on a monthly basis and the agreed amount for generation is credited to schools. Neither of these two meters have smart metering or remote data retrieval capabilities.

Finally, the EDM I MK10A meters (Meter C) were installed as check meters to measure the net flow of power exported to and imported from the TPL network. The present TPL distributed generation (DG) metering policy was established during the installation of this project and TPL decided to test smart MK10A meters in parallel with TPL familiar meters before utilising them for trading purposes, a standard industry practice. TPL are presently investigating a greater utilisation of smart meters for the purposes of revenue metering, prepaid crediting and remote data collection for on-going monitoring and billing purposes.

3.5 TARIFF STRUCTURE

The signed Memorandum of Understanding (MoU) between EcoCARE, MET and TPL included an agreement on the tariff benefits to schools.

- i. TPL has agreed to pay a daily roof rental fee to each school for housing TPL assets.
- ii. TPL has agreed to pay each school a per unit tariff rate for the generation of electricity.

Energy yield of the PV plant:	10306.40 kWh
Grid feed-in:	5689.33 kWh
Consumption:	1587.93 kWh
Self-consumption:	4617.07 kWh
Self-consumption quota (in % of PV energy):	44.8 %

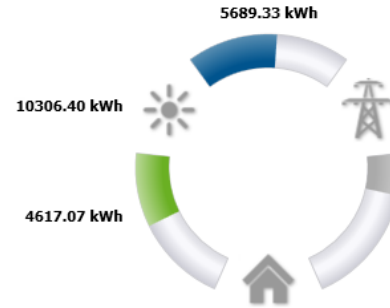

FIGURE 4 SUNNY DESIGN MODEL RESULTS FOR TAKUILAU COLLEGE GENERATION, CONSUMPTION AND FEED IN ESTIMATES

3.6 POWER PRODUCTION ESTIMATES & SIMULATIONS

The maximum total power rating each solar panel can produce is with sunlight orthogonal to the panel. At sunrise and sunset, there is no power output from the panels and the maximum power is available during zenith. Historic weather data, PV system design parameters, schools’ annual energy consumption and estimated school opening hours were used to model an annual electricity generation of 10,306 kWh, an average daily output of 28 kWh for an array of 32 x 250 W panels. Sunny Design, a PV system modelling software programme by SMA was used for this calculation. It assumes that an 8 kW SMA inverter is being used. The results of the modelling are shown in Figure 4.

4 INSTALLATION RESULTS

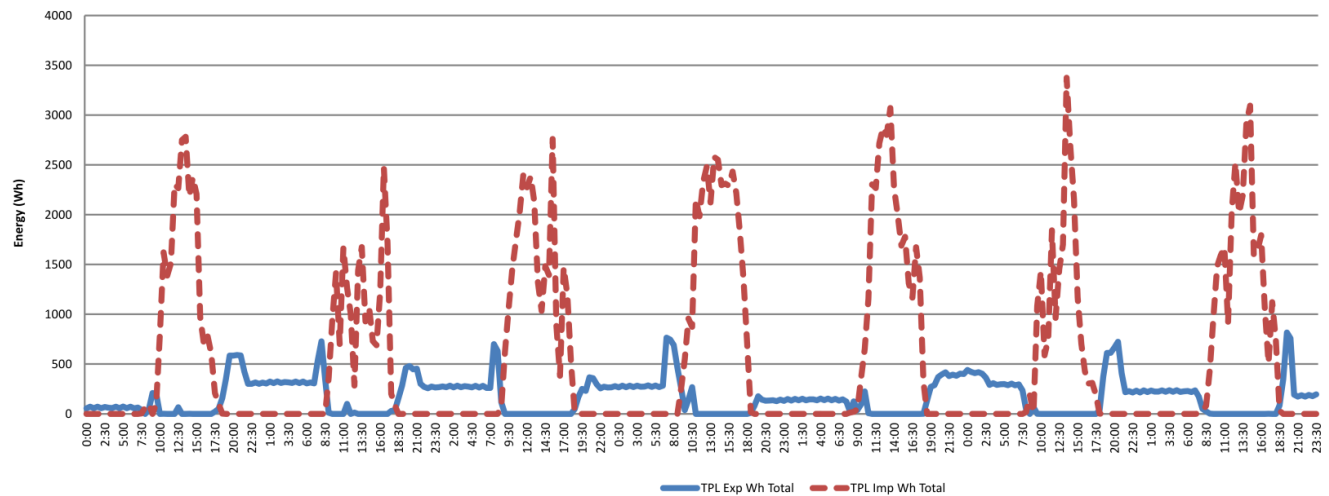

FIGURE 5 TAKUILAU COLLEGE HALF HOURLY REAL ENERGY INJECTION & CONSUMPTION, 20 AUGUST - 26 AUGUST 2012

The PV installations at all five schools are in operation. Takuilau College was the first of the five schools to be installed and commissioned. Half hourly logs of TPL network energy export to and energy import from Takuilau College over a period of one week during the normal school term are presented in Figure 5. During the day when the sun is shining, the PV system generates electricity. The difference between this and the school’s energy use is imported to the TPL

network (red line). During the night there is no PV generation and hence the export from TPL (blue line) is the school's load.

The EDM I installed MK10A 'check meter' was used to log half hourly energy import / export and absolute data. Half hourly minimum, maximum and average phase voltages, maximum phase currents, average phase angles, maximum Phase voltage THDs and system frequency were also logged. Minimum and maximum half hourly logs between 15 August and 26 August 2012 are presented in Table II. Variations in logged values show the system's power quality is not adequate to meet the standards a New Zealand based

TABLE II: TAKUILAU COLLEGE HALF HOURLY LOGS
(15-26 AUGUST 2012)

Half Hourly Logs	Min Value	Max Value
Ph A Voltage average (V)	234.77	258.8
Ph B Voltage average (V)	201.75	244.56
Ph C Voltage average (V)	221.97	251.02
System Frequency average (Hz)	49.97	50.02
Ph A Current max (A)	0.14	21.28
Ph B Current max (A)	0.71	29.32
Ph C Current max (A)	0.16	50.4
Ph A Voltage THD max	2.43	12.14
Ph B Voltage THD max	2.79	18.61
Ph C Voltage THD max	2.16	18.33

electricity distributor would need to comply with. TPL is presently working towards an upgrade of the existing distribution system. Following the upgrade, a detailed monitoring of network's power quality would determine key areas that need attention.

5 FINANCIALS

A total remaining balance of \$118,900 was in surplus and returned to MFAT by Rotary in April 2013, in completion of the project. The remaining balance was partially due to successfully negotiated equipment and materials purchase by project volunteers. The global wholesale cost of PV panels reduced over the course of the project, reducing overall equipment costs.

The cost of the project comes to a total of \$209,430 resulting in a cost of \$5.14 per watt of capacity.

An industry equivalent commercial value of time provided by volunteers towards design, procurement, management, installation and documentation has not been factored into this per unit cost.

Figure 7 details categorised project budget, expenditure and balance.

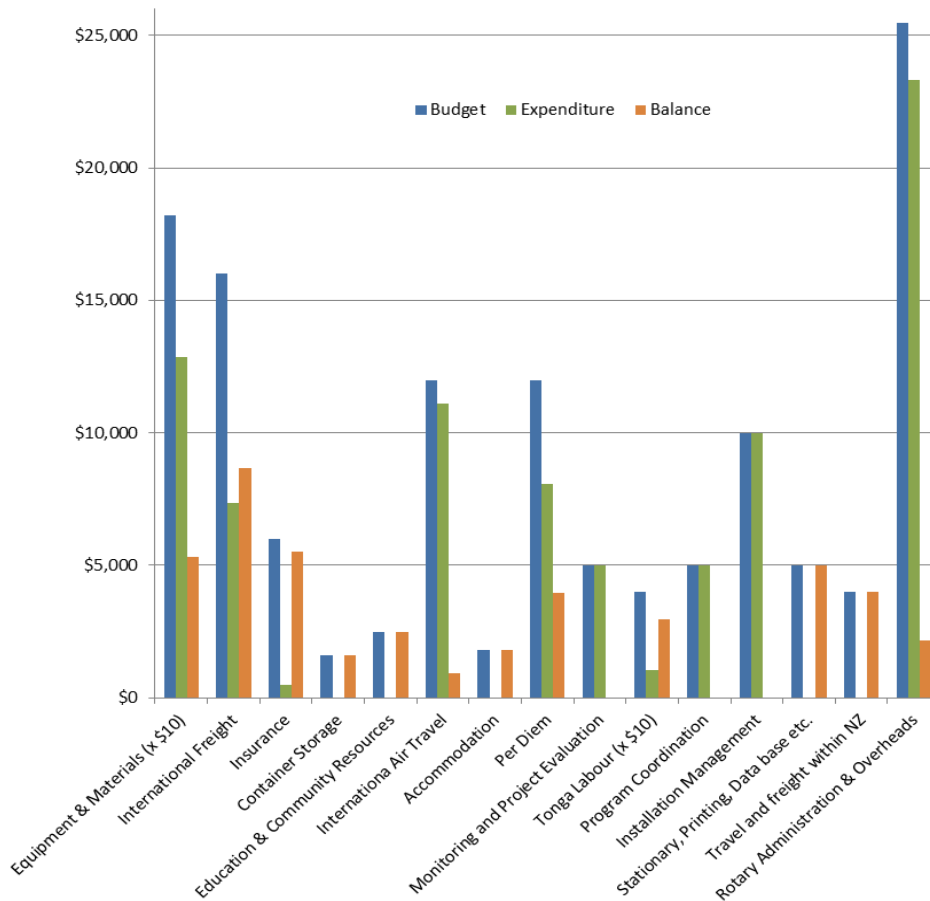

FIGURE 7 TOTAL PROJECT BUDGET, EXPENDITURE & REMAINING BALANCE

6 CONCLUSION

In 2012 a group of volunteers from New Zealand worked in partnership with MET, TPL and JH to install solar power systems of approximately 8 kWp in five Tongan High Schools. Installed assets were handed over to TPL at the request of MET because of TPL’s capacity to maintain and sustain electrical assets. Each installation is connected to TPL’s distribution network and is operating. In January 2013, generated energy ranged from an average of 25 kWh per day at Tupou College to 34.6 kWh per day at Tailulu College. Schools are receiving financial credit from TPL for the use of school grounds to house TPL assets and for the produced energy. The project was funded by MFAT and comes to a total cost of \$209,430 for a combined 40.75 kWp capacity or \$5.14 per Wp.

7 ACKNOWLEDGEMENT

This project would not have been possible without the dedication and enthusiasm of volunteers who were involved through the process. Hamish Lee, Vladimir Abelentsev, Nick Hawke, Alex Finau, Parash Acharya, Andrew Mulligan, Emily Laing, Kate Mang, Blair Marett, and Suzanne Furkert.

The project would not have moved to completion in Tonga without the commitment and support from John Van Brink, Nikolasi Fonua, Lano Fonua and Lani ‘Ahokava from TPL, Josh Helu from JH and ‘Emeli Pouvalu from MET.

A special thanks to Professor Pat Bodger and James Palmer for mentoring the team from project conception to completion and thank you to Russell Taylor for initiating this project.

The crew from Splashroom Media were fantastic to be around. Last but not least, thank you to Mote, Nana and Diana from NOA guest house in Tongatapu for making our stay an enjoyable one, despite our hectic schedule and ever changing catering demands.

8 REFERENCES

- [1] The New Zealand Aid Programme , “Committed to Effective Aid,” New Zealand Ministry of Foreign Affairs and Trade 2011, Wellington, 2011.
- [2] New Zealand Government, “The official website of the New Zealand Government,” 26 March 2013. [Online]. Available: <http://www.beehive.govt.nz/release/635-million-energy-efficient-pacific>. [Accessed 7 April 2013].
- [3] Rotary New Zealand World Community Service, “EcoCARE Pacific Trust in collaboration with Ministry of Education (Tonga) Solar PV and ICT National Programme for Tongan Schools Criteria,” Rotary New Zealand World Community Service, Christchurch, 2012.
- [4] Pat Bodger, “Tonga High Schools PV System Design: Visits to selected schools made from 19-21 October 2011,” Pat Bodger , Christchurch, 2011.
- [5] Tonga Meteorological Service, “Climate Summary of Tonga,” Ministry of Civil Aviation, Nuku'alofa.