



14th Symposium on Earthquake Engineering
Indian Institute of Technology, Roorkee
December 17-19, 2010

Paper No. A0017

DEVELOPMENT OF SEISMIC RETROFIT TECHNIQUE OF RC FRAME USING FULLY FASTENED HAUNCH ELEMENTS: STATIC TO DYNAMIC TESTING

G. Genesio¹, Akanshu Sharma^{1,2}, R. Eligehausen¹, S. Pampanin³, G.R. Reddy²

¹Institut für Werkstoffe im Bauwesen, Universität Stuttgart, Germany, giovacchino.genesio@iwb.uni-stuttgart.de

²Reactor Safety Division, BARC, Mumbai, India, akanshu@barc.gov.in, akanshu.sharma@iwb.uni-stuttgart.de

³Department of Civil Engineering, University of Canterbury, New Zealand, stefano.pampanin@canterbury.ac.nz

ABSTRACT

In this paper an innovative method for seismic retrofitting of poorly detailed reinforced concrete beam-column joints and structures using haunch type elements connected with post-installed anchors is discussed. During an earthquake, the global behaviour of the structure significantly depends on behaviour of the beam-column connections, but no special emphasis was given to that till the eighty's. Therefore, it is recognized that the joints of old and non-seismically detailed structures are more vulnerable and behave poorly under the earthquakes compared to the joints of new and seismically detailed structures. Thus, often the joints of such old structures require retrofitting in order to deliver better response during earthquakes. A relatively new technique for retrofitting the beam-column connections using steel diagonal elements to prevent a brittle failure of the joint core was investigated by mean of experiments on beam-column joints under quasi-cyclic loads and numerical simulations. Highly encouraging results were obtained that proved the efficacy of the system in improving the seismic behaviour of poorly detailed joints. In order to prove their usefulness at the structural level under dynamic loads, shake table tests on 2-D frames are planned. This paper presents the main results of the quasi-static cyclic tests carried out for seismic retrofitting of RC beam-column joints using haunch elements and the further research planned at the structural level. The strengths, limitations and the open issues of the proposed method are discussed in brief.

Keywords: Beam-column joints, frame structures, seismic retrofitting, haunch elements, static and dynamic testing

INTRODUCTION

In seismic-prone countries worldwide there are many buildings, often of high importance (e.g. schools or hospitals), that were built before the introduction of modern seismic oriented design codes. Earthquakes during the last decades have shown that these structures designed with substandard detailing need urgent retrofit and strengthening measures, either to withstand future seismic events with moderate damage, or at least without any collapse. The retrofitting may target the upgrading of the seismic performance in terms of strength and/or ductility (Fig. 1, (a)). Global strategies may be adopted to enhance the resistance of structures to lateral loads (e.g. insertion of shear walls or of steel bracing) or to reduce the effect of the seismic action (e.g. damping systems or base isolation). Local strategies are usually chosen to prevent the brittle failure of structural elements, such as wall and column under shear and to assure a ductile behavior of the structure. The main deficiencies of seismic

Deleted: Figure 1

performance that may be found in RC frames designed for gravity loads only, according to design codes in use before the early 1970s, are generally more related to lack of ductility rather than to inadequate lateral strength. This is usually due to poor detailing of reinforcement and lack of a capacity design philosophy (Priestley, 1997). Typical deficiencies in the detailing of reinforcement are related to the amount and distribution of transverse reinforcement and poor anchorage of longitudinal bars (e.g. use of plain round bars with 180° hooks). As a consequence of the lack of capacity design considerations in the design process, there is no assurance that a suitable hierarchy of strength exists in order to avoid brittle mechanisms. Typical collapse of RC frames may be due to shear failure or occurrence of a plastic hinge in the column which may result in a limited-ductile mechanism such as “strong beam - weak column” (Fig. 1 (b), Priestley, 1997). Furthermore, poor detailing of the reinforcement in frame joints (not sufficient anchorage of longitudinal reinforcement, total lack of or inadequate shear reinforcement in the core) may lead to a premature failure of the joint. The concept of shear hinge was introduced by Pampanin et al. (2003) (Fig. 1 (c)). A ductile beam sway mechanism is shown in Fig. 1 (d).

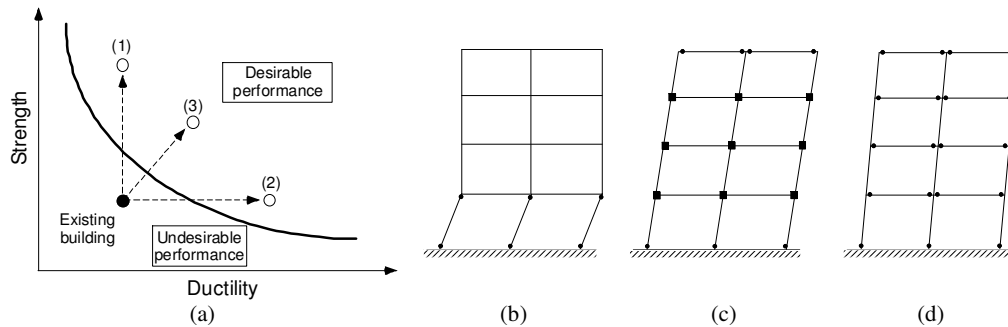

Fig. 1. a) Basic concept for seismic retrofitting; b), c) and d) plastic collapse mechanisms: b) column sway; c) shear hinge sway d) beam sway

In the framework of a research cooperation between University of Stuttgart, University of Canterbury (UC) and Bhabha Atomic Research Centre (BARC), the application of post-installed anchors for the retrofit of exterior beam-column joints is investigated. In Fig. 2 the “Haunch Retrofit Solution” proposed by Pampanin et al. (2006) (Fig. 2 (a)) and further developed by Genesio and Akgüzel (2009) including the use of post-installed anchors in order to reduce the invasiveness of this retrofit scheme (Fig. 2 (c), (d)) is briefly shown. The aim of this retrofit strategy is to modify the internal hierarchy of strength of the beam-column connection and to induce the formation of a ductile flexural hinge in the beam (Fig. 2 (b)) rather than a brittle shear failure in the joint panel (Fig. 2 (b)).

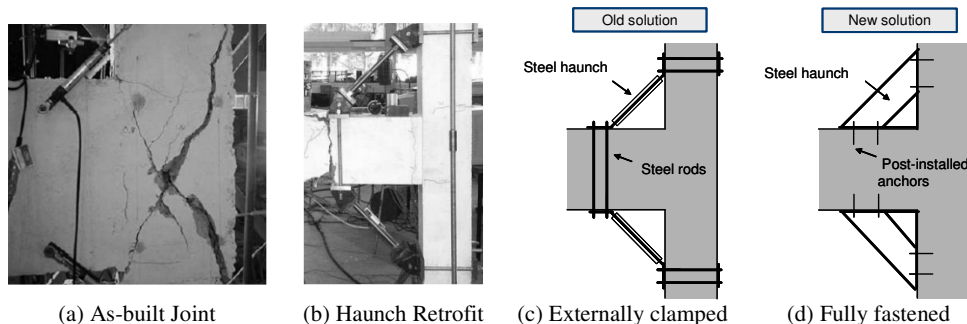

Fig. 2. Haunch Retrofit Solution for exterior beam column joints (Pampanin et al., 2006; (Genesio and Akgüzel, 2009)

In this contribution the results of an extensive experimental campaign on as-built and retrofitted specimen carried out in BARC are briefly shown. After the verification of the positive effect of this retrofit solution at sub-assembly level (beam-column connection), the investigation are planned to

be extended to the structural level by testing as-built and retrofitted 2D-frames on shake table. The motivations as well as the first numerical investigation of the upcoming part of this research project are presented in the following sections.

SUMMARY OF RESULTS OF STATIC TESTS

In the past few years an extensive testing campaign on substandard beam-column connections before and after retrofit has been carried out. The part of the test program on as-built beam-column joints is shown in [Table 1](#). The geometry of the specimens and the test setup are shown in Fig. 3. The specimens were tested under quasi-static cyclic loading. The joints had the same geometry and different reinforcement detailing. The specimens JT1-1 to JT4-1 were designed to fail in shear in the core before yielding of the beam and/or column longitudinal bars occurred. The joint JT5-1 was designed to assure the beam flexural yielding after the first diagonal cracking of the core but before the ultimate joint shear strength is attained. Particular emphasis was given to the definition of the limit states, i.e. 1st diagonal cracking and joint shear strength (peak load) and to the joint shear distortion. The results of the tests are summarised in [Table 1](#), and the different cracking patterns obtained are shown in Fig. 4.

Deleted: Table 1

Deleted: Table 1

Deleted: Table 1

Deleted: Table 1

Table 1. Summary of tests on as-built joints

Specimen ¹	f_c^2 [MPa]	f_{ct}^3 [MPa]	f_y^4 [MPa]	Failure mode ⁵	1 st cracking ⁶			Peak load		
					Drift [%]	V_b^7 [kN]	γ^8 [rad]	Drift [%]	V_b [kN]	γ [rad]
JT1-1	25.4	n.a.	580	JS	2.33 /	67.6 /	0.002 /	3.20 /	79.9 /	0.005 /
					1.11*	39.3	0.001	2.13	61.5	0.004
JT2-1	24.4	3.5	350	JS	0.90 /	28.8 /	0.002 /	3.20 /	41.5 /	0.008 /
					0.84	28.6	0.001	2.13	39.1	0.009
JT3-1	27.5	n.a.	580	JS	0.92 /	25.5 /	0.001 /	3.05 /	38.0 /	0.009 /
					1.13	40.9	0.001	2.28	53.5	0.004
JT4-1	28.2	3.0	580	JS	0.68 /	26.1 /	0.001 /	3.20 /	40.5 /	0.014 /
					1.45	46.6	0.003	2.13	56.8	0.007
JT5-1	24.6	3.4	540	BJ	1.60 /	50.2 /	0.001 /	2.13 /	51.0 /	0.003 /
					1.19	35.7	0.001	2.13	39.5	0.009

¹ For JT1-1, JT3-1, JT4-1 and JT5-1 deformed bars were used; for JT2-1 plain round bars were used;

² Cylindrical compressive strength; ³ Tension strength by splitting test; ⁴ Rein. steel yielding strength;

⁵ JS = Joint shear failure prior beam bars yielding, BJ = Beam bars yielding after joint diagonal cracking;

⁶ Diagonal cracking in the joint panel; ⁷ Beam end load; ⁸ Joint shear distortion;

* Values recorded at the positive / negative loading directions, respectively

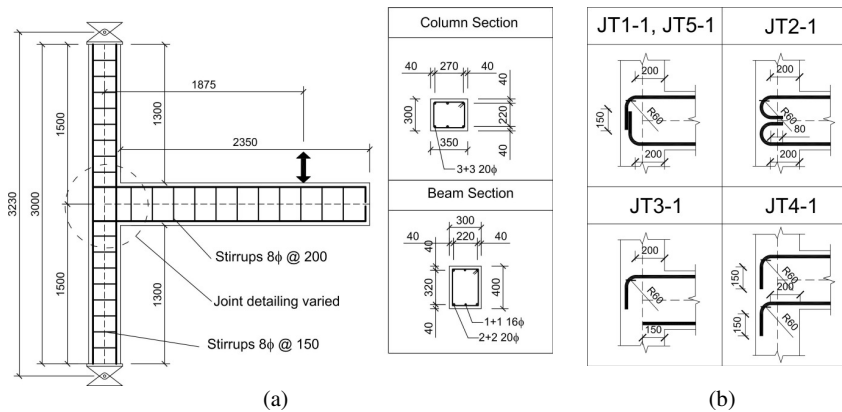

Fig. 3. a) Test setup and geometry of the specimens; b) detail of the anchorage of the beam bars in the joint panel (all dimensions in mm)

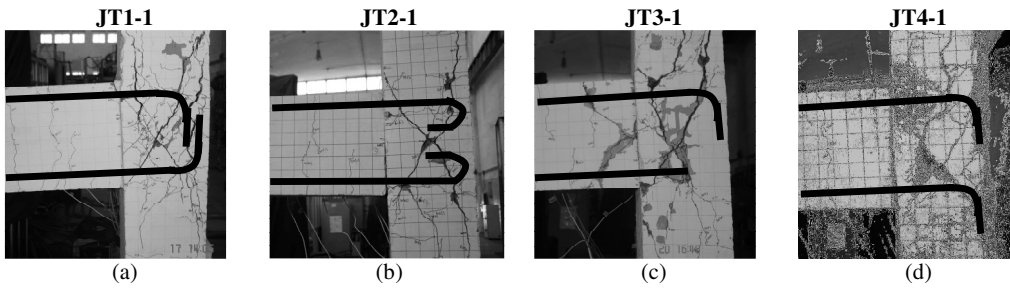

Fig. 4. Influence of anchorage of beam bars in the core on the cracking pattern: a) bars bent into the joint; b) plain round bars with 180°-hooks; c) top bars bent in and bottom bars with straight anchorage; d) top bars bent in and bottom bars bent away from the joint

In the second part of the test program 5 exterior beam-column joints having the same geometry and similar material properties like the benchmark specimen JT1-1 were tested after retrofitting according to the scheme shown in Fig. 2 (d). The geometry of the diagonal steel haunches (Fig. 5 (a)) was kept constant in all the tests and different fastening solutions with post-installed anchors were investigated. In the tests JT1-2 and JT1-3 bonded anchors were used (Fig. 5 (b)) and the anchorage was designed to reach the limit of its capacity (Fig. 6 (a)) to investigate the effect of a partial failure of the haunch on the effectiveness of the retrofit solution. In the test JT1-4 the same anchorage configuration was used, but the beam flexural capacity was reduced by cutting one of the three longitudinal bars in the section, where the hinging was expected. This modification led to a marginal reduction in the capacity of the retrofitted specimen, but also a lower strength demand for the anchorage. The ductility of the retrofitted specimen was very satisfactory (Fig. 6 (b)). For the retrofit scheme of the specimens JT1-5 and JT1-6 concrete screws (Fig. 5 (c)) and expansion anchors (Fig. 5 (d)) were respectively used. Concrete screws seem not to be suitable for this retrofit solution as shown in (Fig. 6 (c)), since no enhancement of the joint behaviour was obtained. The application of expansion anchors seems to be a feasible alternative to the use of bonded anchors (Fig. 6(d)). Their performance was almost comparable to the one of the bonded anchors (higher pinching of the specimen occurred), but they are much cheaper and easier to be installed. Table 2 shows the summary of the parameters of the tests on retrofitted joints.

Table 2. Summary of experimental tests on retrofitted joints

Specimen	f_c^1 [MPa]	f_{ct}^2 [MPa]	f_y^3 [MPa]	Col. rein.	Beam rein.	L^4 [mm]	α^5	Anchorage ⁶	Anchor Type
JT1-2	26.5	2.1							Epoxy
JT1-3	30.2	2.7		3+3	2 D20				Epoxy
JT1-4	33.6	3.1	490	D20	+ 1D16	580	45°	90°-bent in	Epoxy
JT1-5	27.7	3.7							Screw
JT1-6	23.3	3.3							Expansion

¹ Cylindrical compressive strength; ² Tension strength by splitting test; ³ Rein. steel yielding strength;

⁴ Distance between the beam-column interface and the end of the haunch;

⁵ Inclination's angle of the haunch; ⁶ Anchorage of top and bottom beam bars in the joint panel

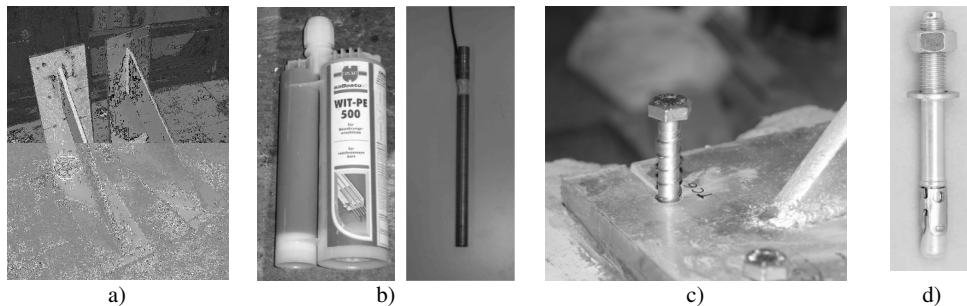

Fig. 5. Haunch installation: a) fully fastened haunch configuration b) epoxy mortar and threaded rod;

Deleted: Fig. 5

Deleted: Fig. 5

Deleted: Fig. 5

Deleted: Fig. 5

Deleted: Fig. 6

Deleted: Fig. 6

Deleted: Fig. 6

Deleted: Fig. 6

Deleted: Fig. 5

Deleted: Fig. 5

Deleted: Fig. 5

Deleted: Fig. 5

Deleted: Fig. 5

Deleted: Fig. 6

Deleted: Fig. 6

Deleted: Fig. 6

Deleted: Table 2

Deleted: Table 2

c) concrete screw; d) expansion anchor

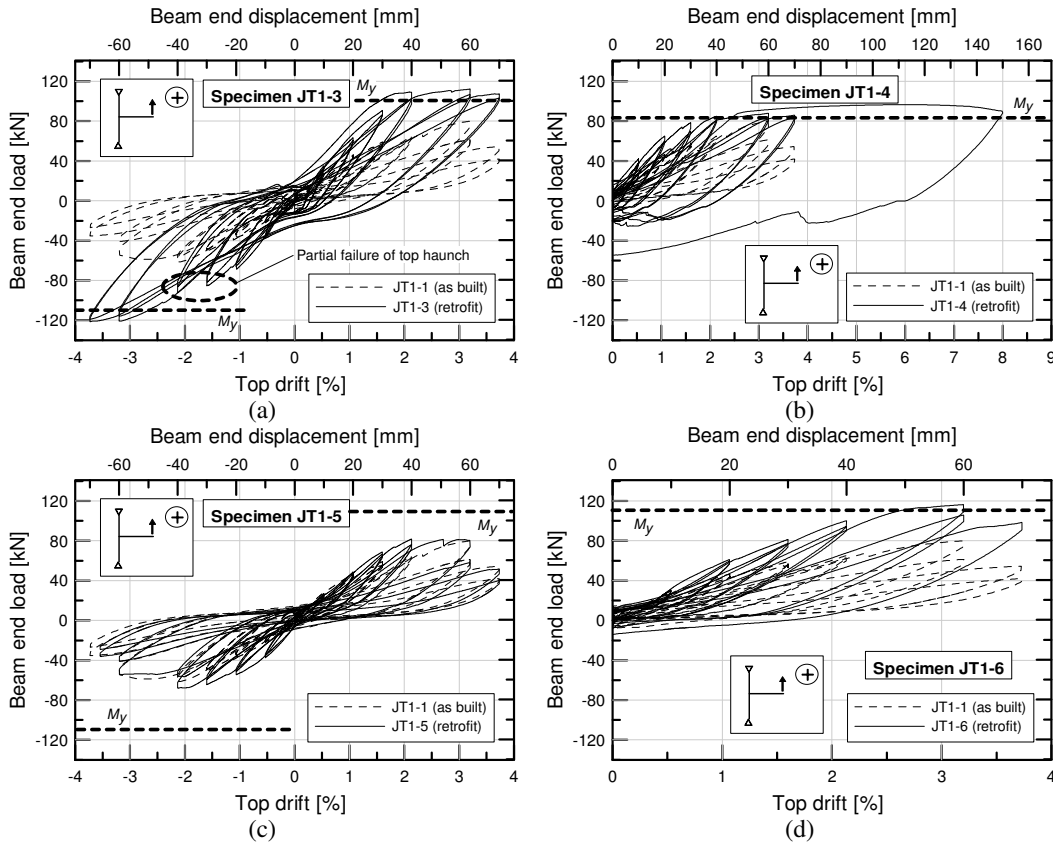

Fig. 6. Investigation of effect of different fasteners configurations on the behaviour of the retrofit: a) tests JT1-3: anchorage with bonded anchors b) test JT1-4: weakening of beam flexural strength (bonded anchors); c) test JT1-5: failure of the anchorage (concrete screws); d) JT1-6: test with expansion anchors

The tests results provided valid data to modify the design model of this retrofit strategies proposed by Pampanin et al. (2006) to include the application of post-installed anchors for the connection of the steel diagonal to the existing structure (Genesio et al. 2010-2). More detailed information concerning the testing of the as-built and retrofitted specimens are available in Genesio, Sharma (2010-1) and Genesio, Sharma (2010-2), respectively.

SHAKE TABLE EXPERIMENTAL PROGRAM

After obtaining quite encouraging results at the sub-assembly level for the fully fastened Haunch Retrofit Solution, it is planned to carry out further investigations at the structural level under dynamic loading testing a 2D frame on the shake table. The basic design of the frames was performed so that the exterior joints of the frames are 2/3rd scale replica of the joints tested in BARC (Fig. 3). The basics of geometry and detailing of a typical specimen is shown in Fig. 7. Additional masses of approximately 1.5 ton will be added on each floor to simulate the self, imposed and live loads and mass of the slab tributary area.

One as-built and three retrofitted specimens are planned to be tested in this experimental program. Same haunch design will be used for all the retrofitted specimens and the difference will be restricted

Deleted: Fig. 7

Deleted: Fig. 7

to the different fastenings used to connect the haunch with the structure. Three different anchors types will be used representing, stiff connection, flexible connection and connections within the two extremities. Each of the structures will be first subjected to a low acceleration level sine sweep test to determine the dynamic characteristics of the structure. This will also serve as a means of comparison for the dynamic characteristics such as time period and damping of as-built and retrofitted structures.

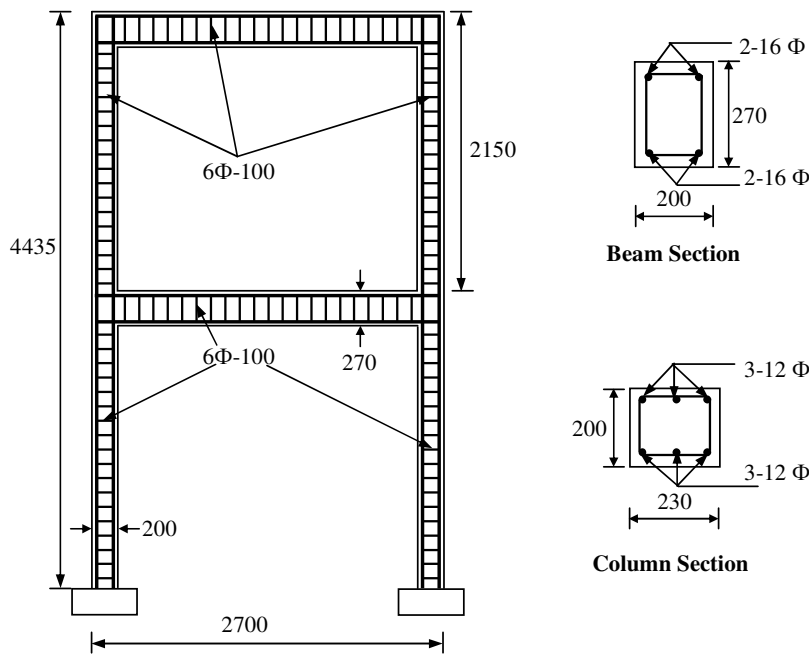

Fig. 7. Schematic of the structure to be tested on shake table

The structures will be subjected to simulated seismic shaking till significant damage is induced. The seismic response of the structures at different levels will be measured using accelerometers. Strain gauges and LVDTs will be used to measure the strains in the reinforcement and on concrete surface at critical locations such as beam and column ends and to measure the joint distortions due to seismic loading, respectively. After the seismic tests have induced damage in the structures, they will again be subjected to sine sweep tests to evaluate the change in dynamic characteristics of the structure due to the damage. Elongation in time period and change in damping of the structure due to damage will be studied. The complete test matrix for the experimental program is shown in Table 3.

Deleted: Table 3

Deleted: Table 3

Table 3. Test matrix for experimental program on dynamic tests

As-built Structure	Retrofitted Structure		
	Retrofit 1	Retrofit 2	Retrofit 3
Pre-Seismic Sine Sweep	Pre-Seismic Sine Sweep	Pre-Seismic Sine Sweep	Pre-Seismic Sine Sweep
Simulated Seismic	Simulated Seismic	Simulated Seismic	Simulated Seismic
Post-Damage Sine Sweep	Post-Damage Sine Sweep	Post-Damage Sine Sweep	Post-Damage Sine Sweep

PRELIMINARY ANALYTICAL RESULTS

In order to ensure that the experimental program will be able to deliver the desired objectives, pre-test pushover type analysis of the structural model for as-built structure was performed to evaluate the failure modes and to obtain an idea about the structural response. Two different types of approaches were followed to perform the analysis. The first analysis was performed using the 3D finite element

approach where the concrete is modelled with solid elements and reinforcement using bar elements. Macroscopic Space Analysis program (MASA) developed at Institute of Construction Materials of the University of Stuttgart based on Microplane model with relaxed kinematic constraint (Ozbolt et al, 2001) was used to perform the analysis. The bond between reinforcement and concrete was considered using the 1D bond elements available in MASA, where the bond-slip relationship is modelled as per model proposed by Eligehausen et al (1983), which was further improved by Lettow (2007). The approach has been earlier successfully utilized to perform nonlinear analysis of poorly detailed reinforced concrete beam-column connections (Sharma et al., 2009 and Genesio et al., 2010-1). Fig. 8 (a) shows the finite element model of the frame structure and the reinforcement and Fig. 8 (b) shows the failure mode of the structure obtained by the analysis. It can be seen that the analysis confirms the prediction of the design of the 2D frame. Most of the damage in the structure shall be concentrated in the joint panel with some damage in the column ends. The beams are suggested to be subjected to minor damage. It should be noted that similar results were obtained from the static tests on the beam-column joints. The predicted results show that haunch elements can offer a good retrofit solution for the structure by re-distributing the forces around the joint so that the joints are safeguarded.

Deleted: Fig. 8
 Deleted: Fig. 8
 Deleted: also showing
 Deleted: Fig. 8
 Deleted: Fig. 8

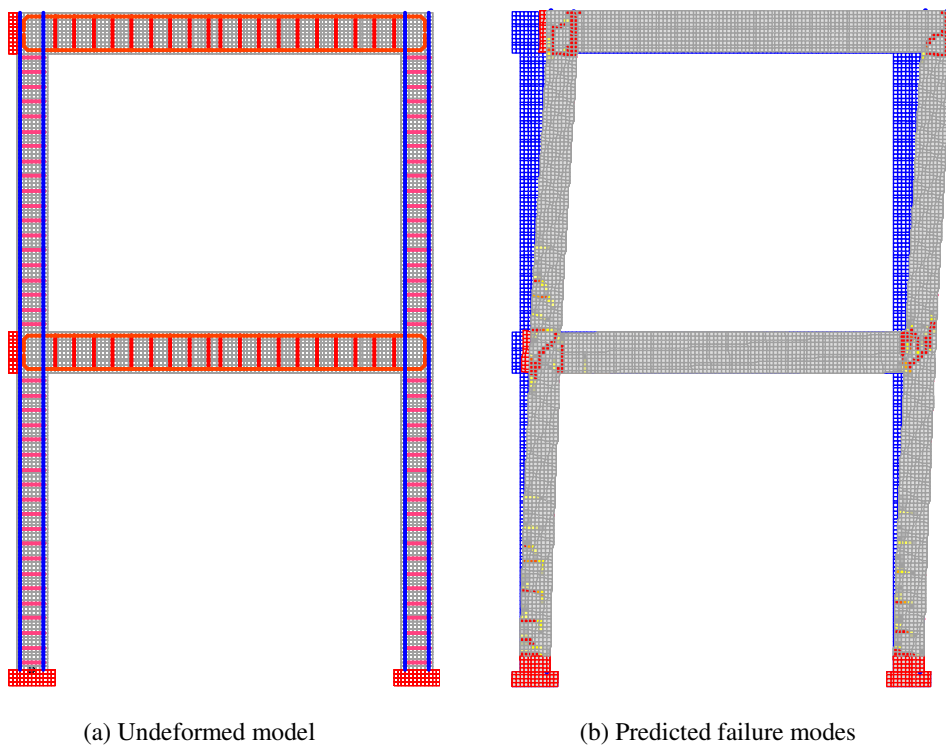

Fig. 8. Results of analysis performed following 3D FE analysis approach using MASA

To confirm the results further and to have higher confidence on the predictions, another analysis of the structure was performed using the frame analysis approach. In this case, the beam and columns were modelled using the frame elements having 6 degrees of freedom at each end. Since, here a planar analysis is performed, therefore; only two translations and one rotation were activated. The moment-rotation hinges were derived for the beams and columns following the Modified Kent and Park model for concrete (Park et al, 1982) and considering strain hardening of reinforcement. However, in such analysis, normally, the joints are considered as rigid and therefore the contribution due to their inelastic behaviour is not considered. Such behaviour is quite unrealistic for such structures having poorly detailed joints. In order to solve this problem, a new joint model proposed by Sharma et al (2009, 2010) was used, which can consider the joint nonlinearity and its contribution to global behaviour of the structure. The model is based on the principal tensile stress in the joint as failure

criteria to determine the joint hinge characteristics following the displacement based assessment of beam-column joints proposed by Priestley (1997). Fig. 9 (a) shows the deflected shape of the as-built structure obtained from frame analysis with joint model. The formation of plastic hinges at critical locations is also shown in the same. The red coloured hinges depict a total hinge formation and pink coloured hinges depict just crossing of yield, whereas yellow coloured hinges depict a situation somewhere between the two extremes. Comparing Fig. 9 (a) and Fig. 8 (b), it can be said that both the analyses predict similar failure modes, where the joint panel suffers the maximum damage. In Fig. 10 (a) the comparison of base shear v/s roof displacement plots obtained for the as-built structure using the 3D FE approach using MASA and using frame analysis approach is shown. The plots obtained by frame analysis while considering joint nonlinearity and while considering joint as rigid are also shown. It can be seen that the plots obtained by MASA and by frame analysis considering joint model compare quite well, whereas the plot obtained by frame analysis considering joint as rigid predicts much higher base shear and a much more ductile behaviour of the frame.

- Deleted: Fig. 9
- Deleted: Fig. 9
- Deleted: Fig. 9
- Deleted: Fig. 9
- Field Code Changed
- Field Code Changed
- Deleted: Fig. 8
- Deleted: Fig. 8
- Deleted: Fig. 10
- Deleted: Fig. 10

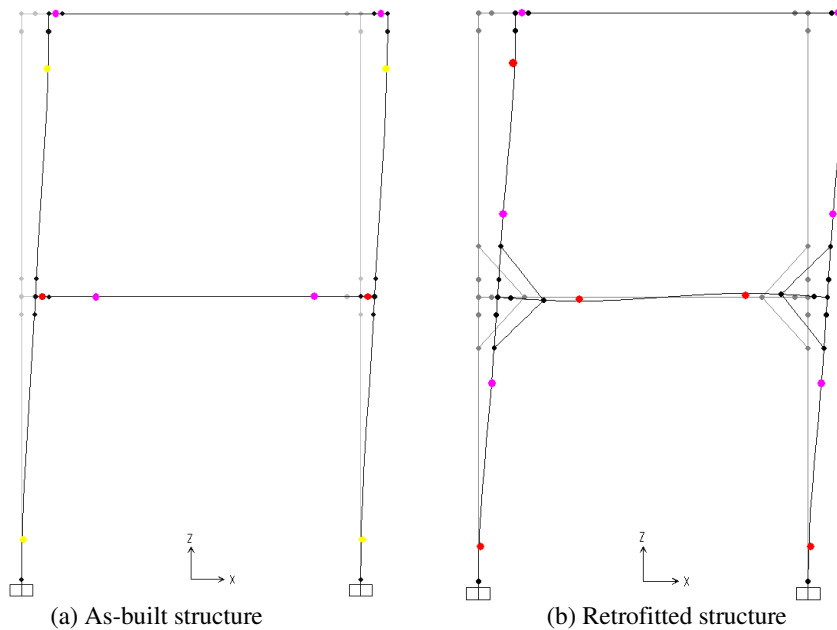

Fig. 9. Deflected shapes and failure modes obtained by frame analysis

Once the failure modes for the as-built structure were ascertained by the analysis, another analysis was performed using the frame analysis approach to predict the behaviour of the retrofitted structure. The hinge properties for the beams, column and joint panel were the same as used for the analysis of as-built structure. The haunch was modelled using frame element and the connection of haunch to the beam and column was considered rigid. Although in the tests conducted on beam-column joints, this connection using anchors were essentially not rigid, but for this preliminary analysis, a perfected rigidity of the connections of the haunches with the existing structures was assumed. However, a detailed analysis considering the nonlinear behaviour of anchors is planned to be performed later. In Fig. 9 (b) the deflected shape and failure modes of the retrofitted specimen is shown. Fig. 10 (b) shows the comparison of base shear v/s roof displacement curves for the as-built and retrofitted structures using the frame analysis approach. It can be seen that the analysis predicts an improved response of the retrofitted structure with much higher peak base shear and better ductility for the same as compared to as-built structure. It can be seen that the major failures have been shifted from the joint panel as observed in as-built structure to failures in beams and columns, which are much more desirable due to ductile response in such case. Thus, it can be said that the pre-test analysis show that

- Deleted: Fig. 9
- Deleted: Fig. 9
- Deleted: Fig. 10
- Deleted: Fig. 10

the as-built structure shall have joint panel as the weakest link and the haunch retrofit solution should be able to safeguard the joint and to transfer the failure modes to the beams and columns.

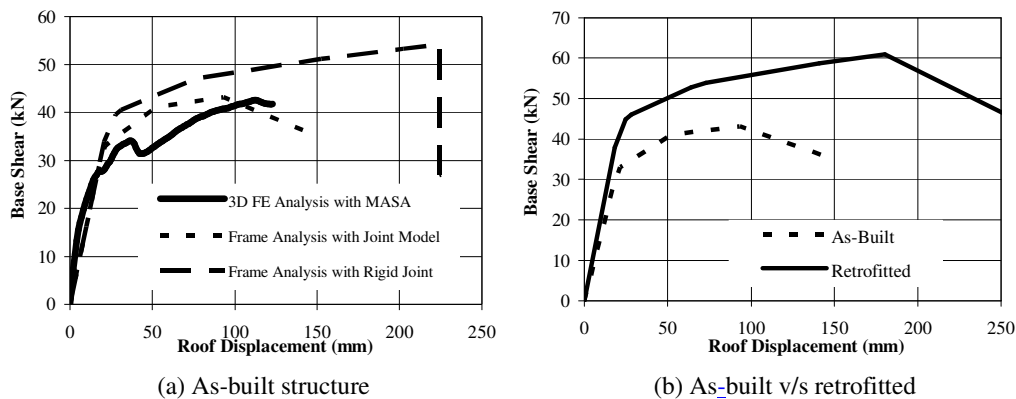

Fig. 10. Comparison of analytical results

CONCLUSIONS AND FUTURE WORK

Reinforced concrete beam-column connections are known to be the critical elements for buildings under seismic excitations, especially if the structure does not fulfill the modern seismic design and detailing requirements. An innovative solution for retrofitting of joints of such structures using two fully fastened steel diagonals was developed and validated with quasi-static experiments on full-scale joints. The results of the experiments, as discussed in this paper, proved that this low invasive and practical solution can be very effective in safeguarding the joints of poorly detailed structure, thereby improving their performance. In order to prove the efficacy of the system at structural level under realistic dynamic loads, an experimental program is designed in which 2D RC frames with poor detailing will be tested on the shake table. One as-built and three retrofitted structures are planned to be tested. Preliminary analyses of the structures showed that the joints of as-built structure will serve as the weak link and the seismic performance of the structure will be poor. Also, it was shown that the haunch retrofit solution should provide an effective retrofit scheme for the structure. The test program will throw light on the following major issues:

- Evaluation of retrofit solution under real dynamic loads;
- Response of anchors under high rate dynamic loads;
- Suitability of different anchor types (stiff / flexible); and
- Suitability and if necessary further refinement of the design method.

References

1. Eligehausen, R., Popov, E.P. and Bertero, V.V., Local Bond Stress-slip Relationships of Deformed Bars under Generalized Excitations, Report UCB/EERC-83/19, Earthquake Engineering Research Center, University of California, Berkeley, 1983, 178p
2. Genesio, G., Akgüzel, U. (2009). Seismic retrofit for reinforced concrete exterior beam-column joints using a fully fastened metallic haunch solution, Part 1: Feasibility study - Test report, No. WS 212/23 - 09/02. University of Stuttgart, Germany.
3. Genesio, G., Sharma, A. (2010-1). Seismic retrofit solution for reinforced concrete exterior beam-column joints using a fully fastened haunch - Part 2-1: As-built joints - Test report, No. WS 221/07 - 10/01. University of Stuttgart, Germany.
4. Genesio, G., Sharma, A. (2010-2). Seismic retrofit solution for reinforced concrete exterior beam-column joints using a fully fastened haunch - Part 2-2: Retrofitted joints - Test report, No. WS 221/08 - 10/02, University of Stuttgart, Germany.

5. Genesio, G., Eligehausen, R., Sharma, A., Pampanin, S. (2010-1). Experimental and Numerical Study towards a Deformation-Based Seismic Assessment of Substandard Exterior R.C. Beam-Column Joints. FraMCoS-7, Jeju, Korea.
6. Genesio, G., Eligehausen, R., Akgüzel, U., Pampanin, S. (2010-2). Application of post-installed anchors for seismic retrofit of RC frames. 14th European Conf on Earthquake Engineering, Ohrid, Macedonia.
7. Ožbolt, J., Li, Y.J., and Kožar, I., "Microplane Model for Concrete with Relaxed Kinematic Constraint", Int. JI. of Solids and Structs. 38, 2001, pp 2683-2711.
8. Lettow, S., 2007, "Ein Verbundelement für nichtlineare Finite Elemente Analysen – Anwendung auf Übergreifungsstöße" Dissertation, IWB Universität Stuttgart, Germany (in German).
9. Pampanin, S., Magenes, G., Carr, A. (2003). Modelling of Shear Hinge Mechanism in Poorly Detailed rc Beam-Column Joints. fib Athens 2003, Paper no. 171.
10. Pampanin, S., Christopoulos, C., Chen, T.-H. (2006). Development and validation of a metallic haunch seismic retrofit system for existing under-designed RC frame buildings. Earthquake Engineering and Structural Dynamics 35:1739-1766.
11. Priestley, N.J.N. (1997). Displacement-Based Seismic Assessment of Reinforced Concrete Buildings. JEE 1:1, 157-192.
12. Park, R., Priestley, M.J.N. and Gill, W.D. (1982), "Ductility of square-confined concrete columns", J. Struct. Eng-ASCE, 108(4), 929-950.
13. Sharma, A., Genesio, G., Reddy, G.R. and Eligehausen, R., "Nonlinear dynamic analysis using microplane model for concrete and bond slip model for prediction of behavior of nonseismically detailed RCC beam-column joints". Journal of Structural Engineering No. 36-29, Vol. 36, No. 4, October-November 2009 pp. 250-257.
14. Sharma, A., Reddy, G.R., Vaze, K.K., Ghosh, A.K., Kushwaha, H.S. and Eligehausen, R., "Joint model to simulate inelastic shear behavior of poorly detailed exterior and interior beam-column connections reinforced with deformed bars under seismic excitations". BARC External Report No. BARC/2009/E/026, December 2009.
15. Sharma, A., Eligehausen, R. and Reddy, G.R., "A New Model to Simulate Joint Shear Behavior of Poorly Detailed Beam-Column Connections in RC Structures under Seismic Loads - Part I - Exterior Joints", submitted to Int Jr of Engineering Structures, Elsevier.