

# In-plane stiffness of wooden floor

A. Brignola & S. Podestà

*Department of Civil, Environmental and Architectural Engineering,  
University of Genoa, Italy.*

S. Pampanin

*Department of Civil Engineering, University of Canterbury, Christchurch.*



2008 NZSEE  
Conference

**ABSTRACT:** The seismic response of existing un-reinforced masonry (URM) buildings is strongly dependent on the characteristics of wooden floors and in particular on their in-plane stiffness and on the quality of the connections between the floors and the URM elements. It is generally well-recognized that adequate in plane-stiffness and proper connections improves the three-dimensional response of the whole system and provides better distribution and transfer of forces to the lateral load resisting walls. Extensive damage observed during past earthquakes on URM buildings of different type have however highlighted serious shortcomings of typical retrofit interventions adopted in the past with the intention to stiffen the diaphragm. Recent numerical investigations have also confirmed that stiffening the diaphragm is not necessarily going to lead to an improved response, sometimes actually having detrimental effects on the response.

The evaluation of the in-plane stiffness of timber floors in their as-built and retrofitted configuration is still an open question and delicate issue, with design guidelines and previous research results providing incomplete, when not controversial, suggestions to the practitioner engineers involved in the assessment and/or retrofit of these types of structures.

In this contribution, a summary of the state-of-the-art related to the role of the in-plane stiffness of timber floors in the seismic response of un-reinforced masonry buildings is presented and critically discussed based on the limited available experimental and numerical evidences. A framework for a performance-based assessment and retrofit strategy, capable of accounting for the effects of flexible diaphragm on the response prior and after the retrofit intervention, is then proposed. By controlling the in-plane stiffness of the diaphragm, adopting a specific strengthening (or weakening) intervention, the displacements, accelerations and internal forces demand can be maintained within targeted levels, in order to protect undesired local mechanisms and aim for a more appropriate hierarchy of strength within the whole system.

## 1 INTRODUCTION

The experience of past earthquakes has shown that the seismic response of existing masonry buildings is strongly dependent on the characteristics of wooden floors and in particular on their in-plane stiffness and on the connections quality between the floors and masonry elements. The horizontal diaphragms play a key role in the transmission of the seismic actions and the quality of the connections allows the structure to activate its 3-dimensional resources. On the other hand, damage and failure observed during past earthquake demonstrate that an inappropriate use of retrofit techniques can lead to dramatic consequences. Figure 1 shows typical undesired out-of-plane collapse mechanisms observed in the Umbria-Marche earthquake (1997), due to excessively stiff diaphragms with inadequate connection to the walls.

International guidelines on seismic rehabilitation of buildings (FEMA 356 2000, NZSEE guidelines 2006, OPCM 3274 2005) and international literatures (Tena-Colunga & Abrams 1992, 1995, 1996)

underline that it is very important to correctly include in the analytical model the diaphragm flexibility and account for the out-of-plane loading of the walls. However, it is neither specified nor clear from the literature, how to account for these effects in a simple manner. Similarly, the importance of the connections between the vertical walls and the diaphragms is recognized to play an important role in the overall response of the masonry buildings. Yet there is inadequate information on how to evaluate such effects.



Figure 1. Damages on masonry buildings observed during the Umbria-Marche (Italy) earthquake in 1997. a) b) c) Buildings in Sellano's (PG) historical centre. d) St. Stefano Church in Nocera Umbra (PG).

The diaphragm action clearly depends on the type of floor. Focusing herein the attention on timber floors it is of interest to properly evaluate the in-plane-stiffness of existing (as-built) and retrofitted configurations. Some codes (FEMA 356 2000) provide reference stiffness values for different type of timber floors, others (NZSEE Assessment guidelines 2006) propose analytical simplified procedure to determine the in-plane stiffness starting from the geometrical and technical characteristics of the floor.

It is worth noting, however, that very few experimental results are available to support such empirical values or evaluation procedures (Corradi et al. 2006, Piazza et al. 2008, Peralta et al. 2003, 2004). Furthermore, when looking at the available experimental results, different test set-up have been adopted with significant discrepancies in the boundary conditions, aspect ratio, type of floors and measured parameters. A further controversy is evident when discussing which in-plane "stiffness" to adopt from the experimental test results. Given the high non-linearity of the response at earlier stages of the response, due to the nails behaviour, major differences can in fact derive from the different evaluation of an initial stiffness, secant stiffness or tangent stiffness. Benchmark values and testing protocol are not available.

The effects of timber diaphragms and the crucial need to evaluate and control the stiffness (maybe within acceptable ranges) are further emphasised when developing an adequate retrofit strategy: some international guidelines on the rehabilitation of the URM building (OPCM 3274 2005) suggest few option for the strengthening of the horizontal diaphragms. Although the general trend consists of proposing to increase the in-plane stiffness, it is clearly reminded that an increase of the floor in-plane stiffness per-say is not necessary going to improve the global response of the building.

In this contribution, a retrofit strategy aiming at improving the global behaviour of the building, changing the hierarchy of strength of local mechanisms by modifying the in-plane stiffness of the

diaphragms is proposed. According to a performance-based retrofit approach, the efficiency of alternative retrofit techniques (i.e. concrete topping, FRP, cross board, steel plates) in controlling the stiffness of the diaphragm and thus obtaining the aforementioned desired global mechanism can be assessed.

After providing a summary of the state-of-the-art regarding the role of the in-plane stiffness of timber floors in the seismic response of the masonry buildings, considerations on local and global mechanisms and hierarchy of strength, as affected by the diaphragm stiffness, are given. An overview on alternative retrofit techniques for existing timber floors is presented along with a critical discussion on the theoretical and experimental evaluations of the diaphragm stiffness.

## 2 AS-BUILT TIMBER FLOORS AND STRENGTHENING TECHNIQUES

Timber floors typically adopted in URM buildings are very simple structures consisting on beams (joists) and cross boards nailed to the main elements. Either one-way or, when larger span are required, two-way (cross bonded) floors are used (Fig. 2).

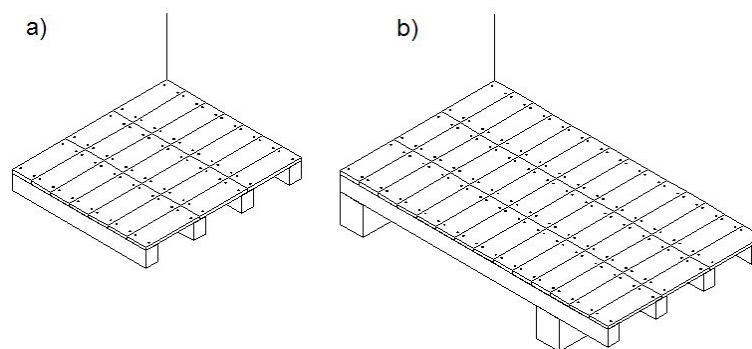

Figure 2. Traditional layout of timber floors (a) one-way and (b) two-way (cross bonded).

### 2.1 Strengthening of the floor unit

Alternative seismic retrofit techniques for timber floor diaphragms are available and adopted as viable solution in recent guidelines for seismic assessment and retrofit (OPCM 3274, 2005):

- Cross laminated plywood sheet: consisting of the superposition of a new layer of wood planks or plywood panels over the existing sheathing: usually the planks and the panels are crossly arranged to the existing ones and fixed with screws or nails (Fig. 3a).
- Fiber reinforced Polymers (FRP) or steel plates: consisting of the application of diagonal bracing on the existing wood planks and can be done using wide sheets of composite materials (FRP) glued to wood by means of epoxy-based resin (Fig. 3c), or adopting light steel plates, nailed to the planks.
- Concrete Topping for composite action: a very common and traditional retrofit method, consisting of the use of a lightweight concrete topping (40-50 mm thick) with or without steel connectors. The slab reinforcement is usually composed of welded wire-mesh (5-6 mm diameter) (Fig. 3b). The connection between the wood rafters and the concrete slab can be obtained through different types of connectors (e.g., nails, L-shaped elements made of steel bars, axial connectors).

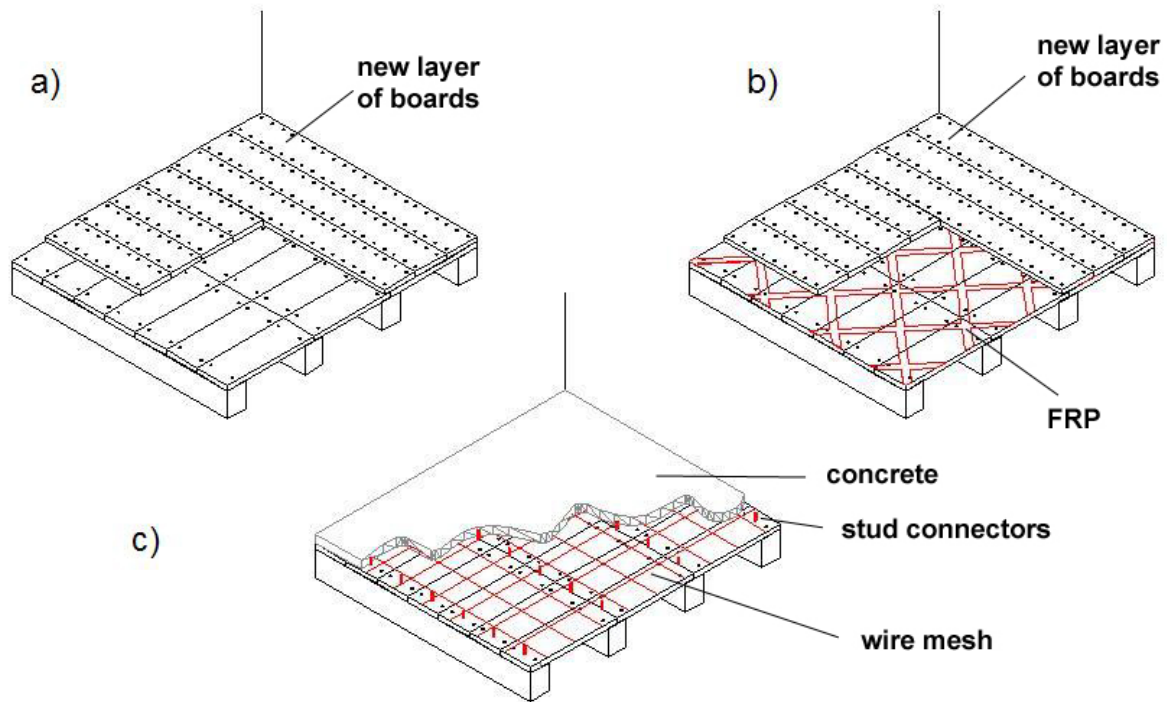

Figure 3. Typical retrofit techniques for existing timber floors: a) new layer of wood planks; b) diagonal bracing of composite materials (FRP); c) additional concrete topping.

## 2.2 Strengthening of the floor-to wall connection

Existing timber floors are usually connected to the lateral walls only by interlocking between timber beams and masonry and in some cases by means of steel ties to improve the local link between masonry and beams (Fig. 4a, 4b). In the past, in order to obtain a substantially rigid connection between timber floors and masonry unit, the insertion of concrete curbs “within” the depth of the masonry walls has been a widely adopted technique. The extensive damage observed during past earthquake have highlighted that an inappropriate use of this standard technique can lead to dramatic consequences due to the excessive weakening of the existing masonry walls. Reversible and not invasive techniques are in general preferred and suggested by guidelines (Fig. 4): an efficient connection between the wood diaphragm and the masonry walls can be obtained by using a system shown in Figure 4e (Doglioni, 2000). L-shaped steel elements are connected to the floor by means of screws; both ends of the profile are connected to the lateral masonry unit through threaded steel bars (20-30 mm diameter), chemically or mechanically connected to the masonry walls.

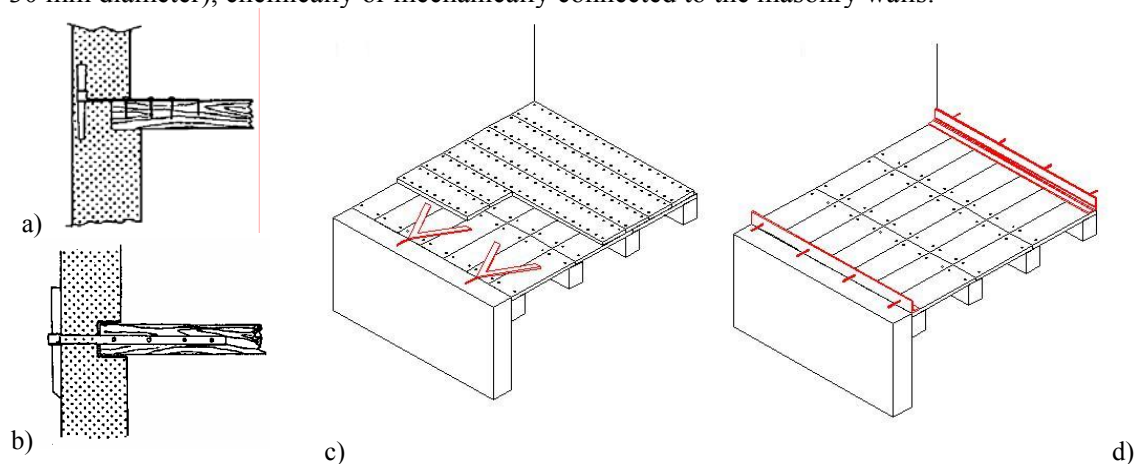

Figure 4. Typical retrofit techniques adopted to improve the connection between timber floor and masonry walls: a) b) steel ties; c) steel ties perpendicular to beams way; d) L-shape perimeter steel element (Doglioni, 2000).



### 3 SEISMIC RESPONSE OF MASONRY BUILDINGS WITH FLEXIBLE TIMBER DIAPHRAGM

According to international guidelines on seismic rehabilitation of buildings (e.g. NZSEE guidelines 2006, OPCM 3274 2005), both the global and local behaviour of URM buildings have to be assessed, accounting for partial/local collapse mechanisms, either in plane or out-of-plane. As mentioned, the damage observation from past earthquakes has confirmed the key role of diaphragms flexibility in affecting the collapse mechanism and, in general, the overall response.

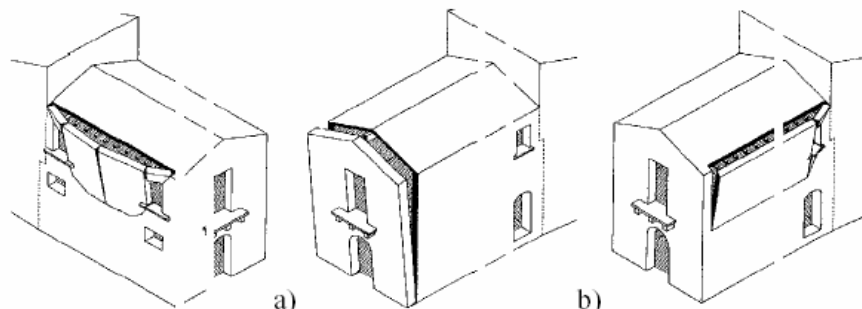

Figure 5. First-mode collapse mechanisms: out-of-plane wall overturning (De Benedictis et al.,1993).

An excessively flexible diaphragm and inadequate tie-in connection between walls and floor can lead to excessive displacement at the floor level, possibly causing overturning of the perimeter out-plane-walls (typically referred to as first-mode of failure and considered the least desirable (Fig. 5). Stiffening the diaphragm by substituting or retrofitting the existing timber floors can limit such out-of-plane behaviour, while increasing the distribution of shear forces to the lateral resisting walls (in-plane). Poor quality of the masonry or the presence of significant opening can lead to shear, sliding-shear or rocking mechanism (typically referred to as second modes).

Furthermore, damages and failures occurred during the Umbria-Marche (Italy) earthquake in 1997 have shown that in-plane stiff diaphragms, yet badly connected to the walls, can still generate undesirable collapse mechanisms as the expulsion of the corners (Fig. 6b, 6c), hard to predict mechanism. Torsion mechanisms can in fact be activated by the stiff floor (depending on the eccentricity between centre-of-mass and centre-of-stiffness) without the possibility to rely upon a restraint action due to the poor wall-to-floor connection detailing. The presence of a rigid diaphragm can limit the out-of-plane rotation of the masonry units while causing a concentration of outwards forces in the corners (Fig. 6a).



Figure 6. Angular deformation of the masonry unit and expulsion of the building corners.

International literature confirms the critical role of flexible diaphragms in the overall seismic response of the masonry buildings. Tena-Colunga & Abrams (1992, 1995, 1996) developed analytical dynamic models to study the behaviour of some masonry buildings which were subjected to the 1989 Loma Prieta Earthquake. They showed that a rigid diaphragm assumption is not necessarily conservative for the assessment of many existing buildings, since it underestimates the acceleration of diaphragm and

shear walls as well as out-of-plane displacement of walls. For the purpose of this paper, thus, a retrofit solution targeting an increase in stiffness would, as a general benefit, lead to a reduction of out-of-plane displacement and, possibly, accelerations. On the other hand, as the diaphragm flexibility increases, torsional effects were demonstrated to be reduced. Again for the scope of this paper, this would suggest that, when torsion is a concern due to the layout of the building, a no-intervention, if not even a reduction in diaphragm stiffness, would be suggested.

Few shaking table tests have been carried out on full-scale or half-scale masonry buildings (Paquette & Bruneau 2006, Cohen et al. 2002). In contrast to what is usually assumed in design, URM buildings with flexible floor diaphragms do not behave as SDOF systems (associated to the in-plane response of the shear walls). Rather, they tend to behave as at least a 2DOF, with the second degree of freedom associated with the in-plane response of the timber diaphragm.

Numerical studies on the seismic response of historical URM building with timber diaphragms have been carried out at the University of Trieste, Italy (Gattesco et al. 2007), in order to evaluate the effectiveness of a strengthening technique for timber floor aimed to increase the in-plane stiffness. The numerical analysis on floors loaded in their plane showed a significant increase in the in-plane stiffness when strengthened steel plates, connected to the timber beams through steel dowels were placed parallel to the beams diagonally above the existing boards. The resultant floor in-plane stiffness, derived using the numerical model, was up to 50 times larger than that associated to the as-built configuration. As mentioned, a predefined change to the failure mechanism can be controlled by modifying the in-plane stiffness of the diaphragm by a retrofit intervention. In the as-built configuration, overturning of the out-of plane walls was observed, due to the excessive in-plane displacement of the floor. By increasing the stiffness of the diaphragms, according to the proposed technique (which included a typical tie-back action with the out-of plane walls) the overturning mechanism could be protected, while engaging the parallel walls. Failure of the shear walls would eventually occur, though after a substantial increase in the overall lateral load capacity (50% increases in the base shear) (Fig. 7).

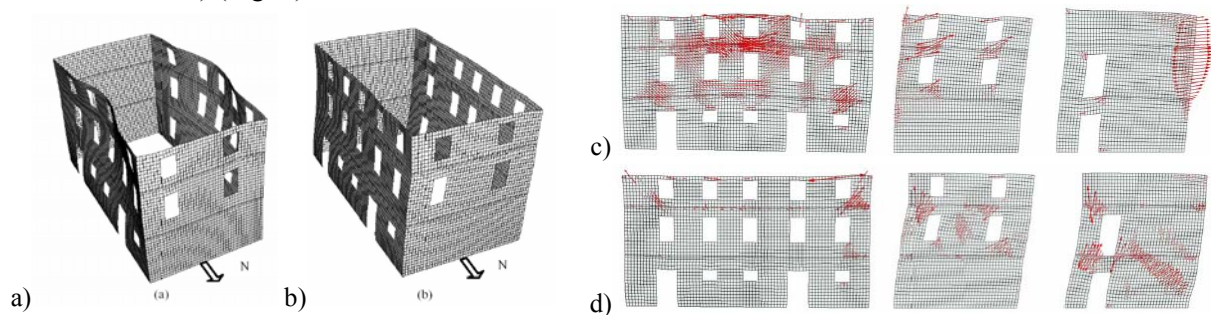

Figure 7. Numerical of simulated response of an un-reinforced masonry building: deformed shape for (a) flexible diaphragm or (b) rigid diaphragm; maximum principal deformation (tensile stresses) for (c) flexible diaphragm and (d) rigid diaphragm. (Gattesco et al. 2007)

### 3.1 Parametrical analyses on a 2:3 scale UMR building

In order to gain a better understanding of the effects of flexible diaphragms in the behaviour of masonry buildings under seismic actions extensive numerical investigation are under going on a series of prototype buildings. As an example, the results of pushover analyses on a simple two storeys UMR building (Fig. 8a) are shown. The building, 2:3 scale, represents a test-building for shake-table tests at the Enea Laboratory, Rome, Italy (TREMA Project, Technologies for the Reduction of seismic Effects on Architectural Manufactures 2006). The analyses has been carried out using the program Tremuri, developed by the University of Genoa (Galasco et al. 2001) specifically for the daily use of practitioner engineers. The walls are modelled as equivalent frame (Fig. 8c) and the out-of-plane modes are not taken into account. The masonry elements, piers and spandrels, are modelled by non linear beam elements (6 DOF) characterized by a bilinear behaviour. The floor system are modelled by means of elastic elements with a user-defined in-plane stiffness ( $E_{xeq}$ ,  $E_{yeq}$ ,  $G_{eq}$ ). As described in the following paragraph, the latter should take into account either the diaphragm-only stiffness as well as the connectors contribution. Four different in-plane stiffness were considered: the first case is

representative of the as-built floor configuration ( $G_{eq} = 7.5$  MPa), the second and the third one represent stiffer floors as a result of two retrofit intervention on the diaphragm ( $G_{eq} = 15$  MPa;  $G_{eq} = 75$  MPa), the last one represent, ideally, an infinitely rigid diaphragm, often used in the analyses ( $G_{eq} = 750$  MPa).

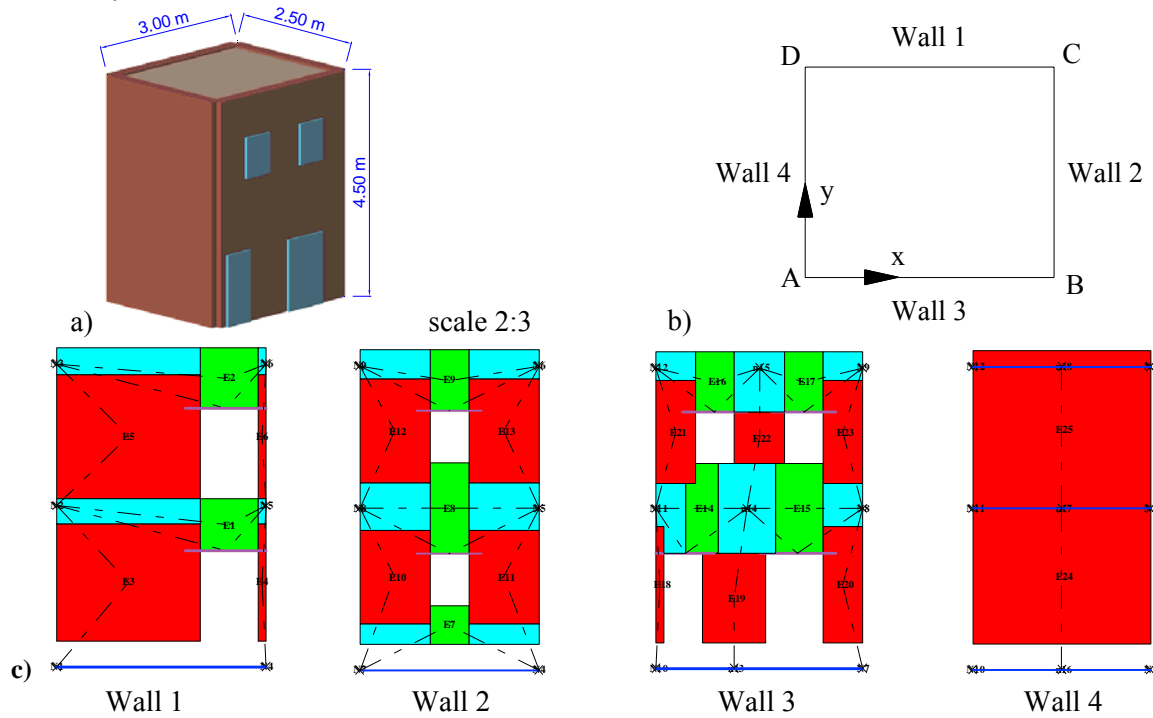

Figure 8. Equivalent frame model for a two-storey, 2:3 scaled test UMR building (TREMA 2006).  
 a) Three-dimensional view; b) Plan draft; c) Equivalent frame model for the different walls.

In Figure 9 the results of push-over analyses (in x-direction) are shown. For each diaphragm stiffness, the capacity curves representative of the equivalent SDOF oscillator are plotted within an acceleration-displacement diagram and compared with the (NZS1170 2004) Design Response Spectra, (500 yrs and 2500 yrs return period,  $PGA=0.13g$ , different soil classes). In particular for the soil class A and the 500 yrs return period, the building performance point was determined in order to compare the results related to the performance point of each model.

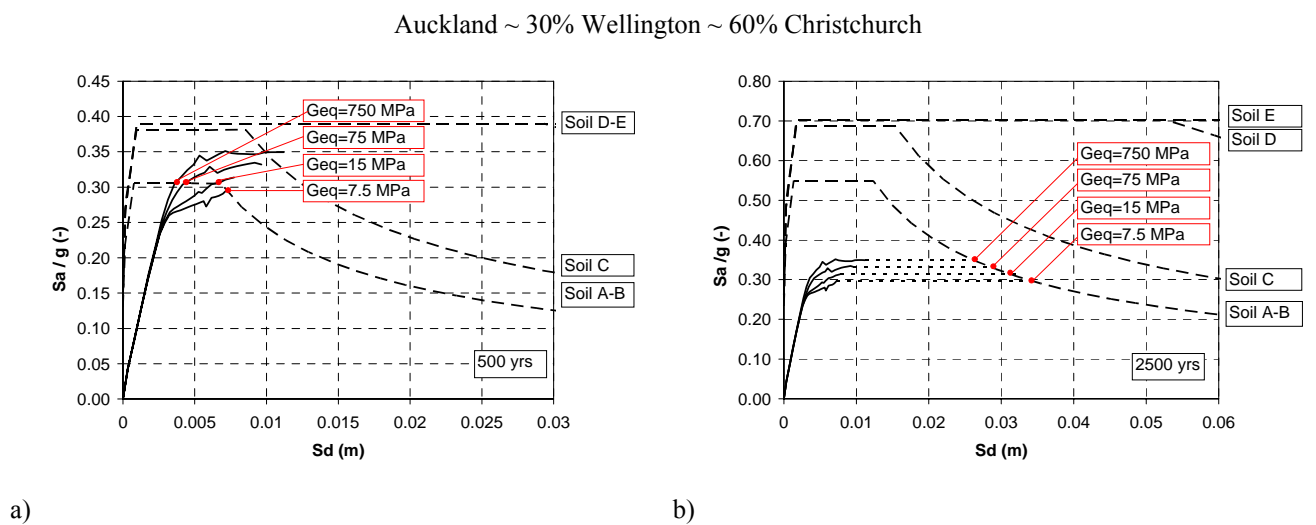

Figure 9. Results of push-over analyses for different diaphragm's equivalent shear modulus.  
 Comparison with Response Spectra and identification of performance point.  
 a) 500 yrs return period; b) 2500 yrs return period.

Figure 10 represent the snap-shot of the deformed shape (plan view, wall 1 and wall 3 elevation views) achieved at the performance point, while Figure 11a and Figure 11b show the inter-storey drift values for each walls as well as the floor torsional rotation for each level. It can be noted that, when increasing the diaphragm stiffness as a result of the retrofit intervention, the inter-storey drift demand on the weakest wall decreases significantly: for the as-built configuration wall 3 presents a very high inter-storey drift on the second level, and this is considerably reduced at diaphragm increasing and for the infinitely rigid diaphragm is almost equal to the inter-storey drift of wall 1; consequently the torsional rotation of the floors is reduced at diaphragm increasing.

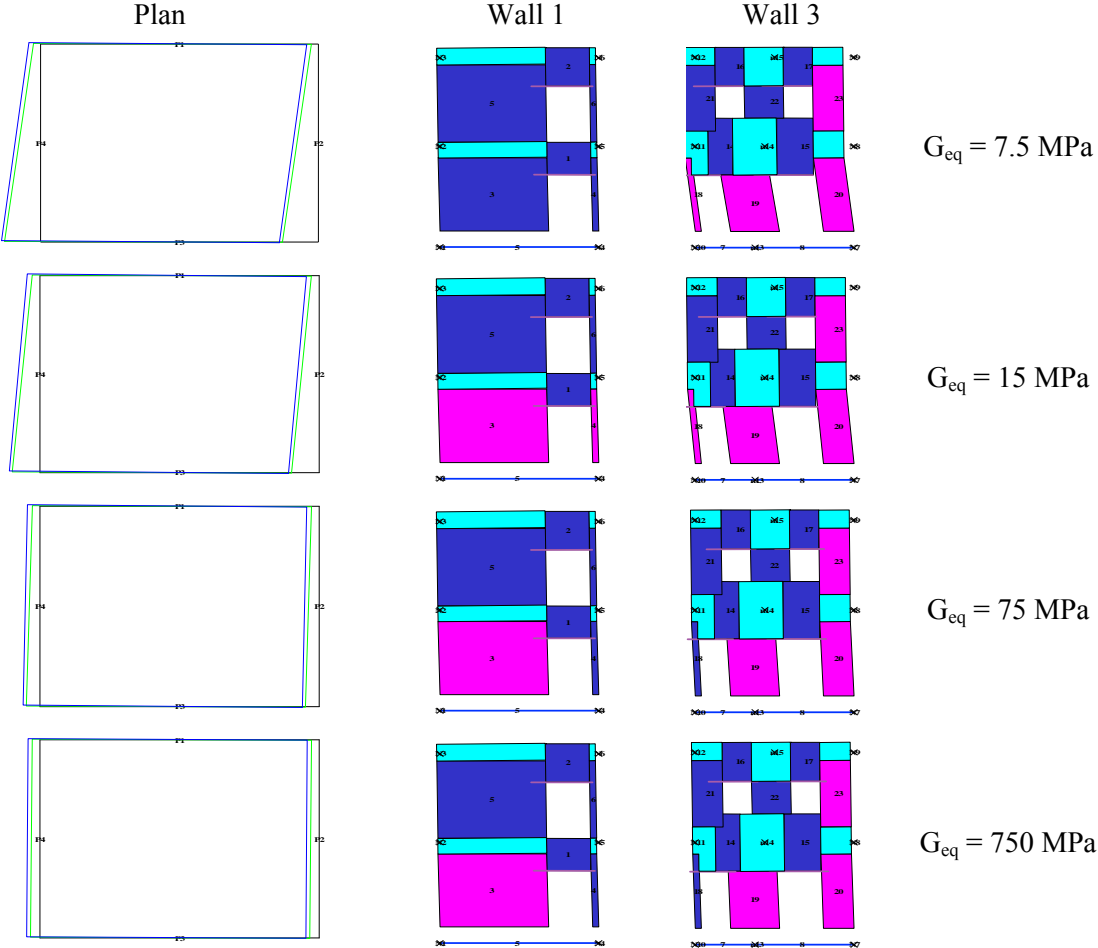

Figure 10. Deformed shape for different diaphragm stiffness.

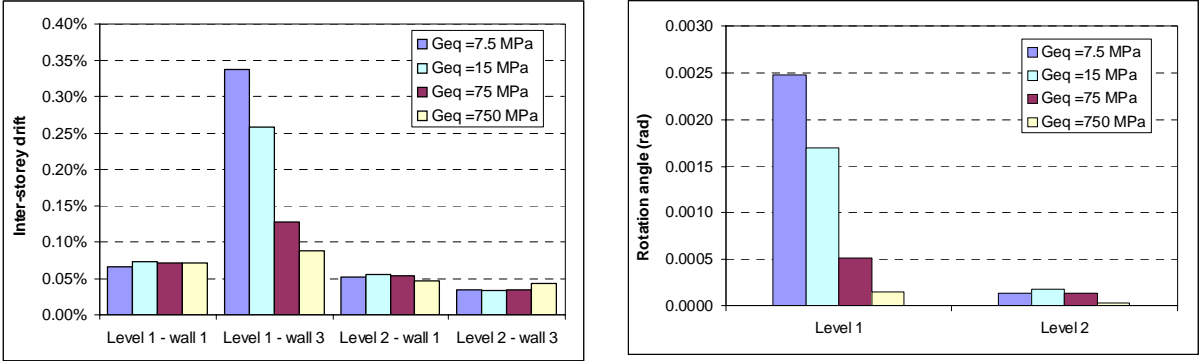

Figure 11. a) Inter-storey drift for each level and each wall; b) Torsional rotation for each level.



**Table 1. Inter-storey drift and torsional rotation.**

		$G_{eq} = 7.5 \text{ MPa}$	$G_{eq} = 15 \text{ MPa}$	$G_{eq} = 75 \text{ MPa}$	$G_{eq} = 750 \text{ MPa}$
Inter-storey drift (%)	Level 1 - wall 1	0.07%	0.07%	0.07%	0.07%
	Level 1 - wall 3	0.34%	0.26%	0.13%	0.09%
	Level 2 - wall 1	0.05%	0.06%	0.05%	0.05%
	Level 2 - wall 3	0.03%	0.03%	0.03%	0.04%
Torsional rotation angle (rad)	Level 1	0.00247	0.00169	0.00051	0.00015
	Level 2	0.00014	0.00017	0.00014	0.00003

#### 4 RETROFIT STRATEGY

According to the aforementioned considerations, which summarize information available in literature, code guidelines provisions as well as observations during the past earthquakes, it appears evident that a proper retrofit strategy for URM buildings aiming to control both global and local behaviour can actually target the modification of the in-plane stiffness of the diaphragm as a means to achieve a more desirable hierarchy of strength.

In general and well known terms, when considering the global behaviour and, in particular, for a given analysis method (e.g., linear static, non linear static, dynamic) and model assumption (e.g., three-dimensional, two-dimensional, equivalent frame, ...) the building capacity can be evaluated and compared with the required demand depending on the earthquake intensity. Such a performance point can be compared with the targeted Limit States or performance objective associated to alternative failure mechanism.

Following capacity design principles, the hierarchy of strength of alternative local collapse mechanisms can in fact be evaluated during the assessment phase, by for example evaluating their collapse factors (Lagomarsino et al. 1999) and relating them to the equivalent base shear and, from there, to the peak ground acceleration (of a spectrum compatible record) which would cause that collapse. Each mode can also be triggered by either excessive displacement, or excessive acceleration or a combination of the above. Limit states (damage level) associated to each mode could and should thus be developed.

It is worth reminding that international guidelines define both strain and stress Limit States in order to ensure, respectively, usability of building (Damage Limit State) and collapse (Ultimate Limit State) both for the in-plane and the out-of-plane behaviour of URM buildings. Referring to the Italian document (OPCM 3274 2005), for each local collapse mechanism the Damage Limit State correspond to the activation of the mechanism and the Ultimate Limit State correspond to the collapse of that mechanism: in the first case the spectral acceleration has to be checked, in the second one the maximum displacement (Fig. 12). The NZSSE Guidelines (2006) suggests a comparison between the displacement response (demand) for the wall panel subject to an earthquake of the intensity specified and the deflection that would caused instability.

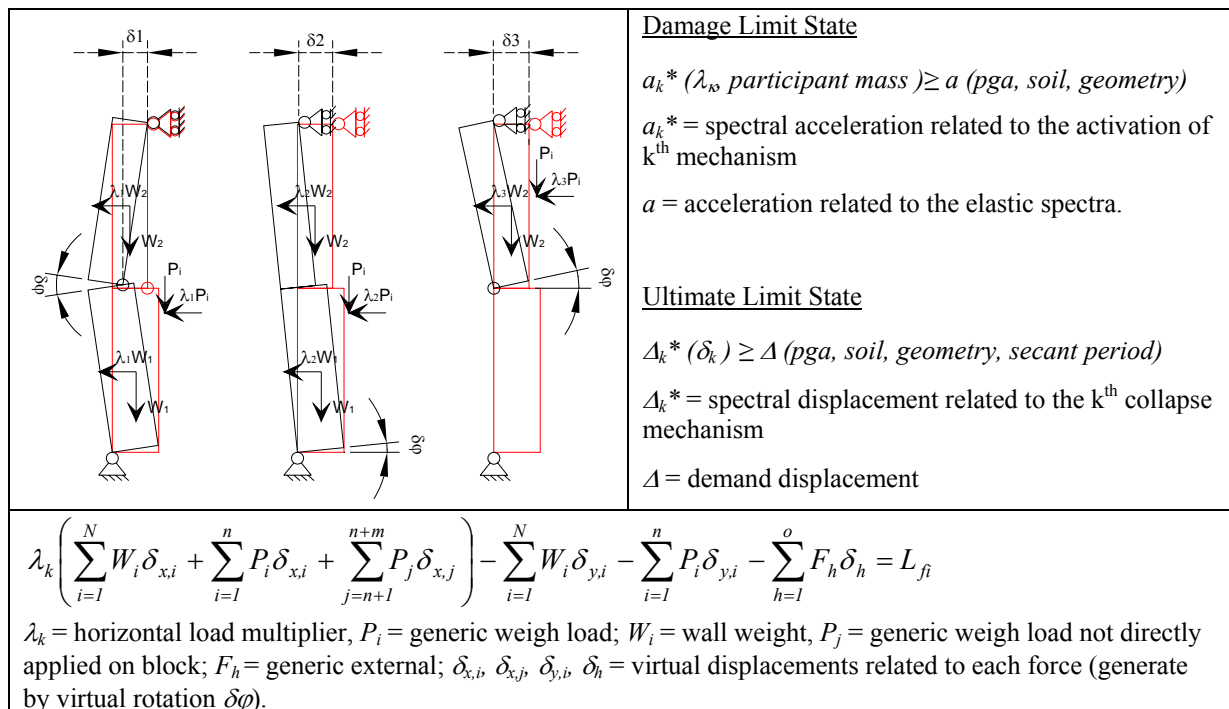

Figure 12. Evaluation of local collapse mechanism out-of-plane and related limit states according to OPCM (2006).

If the building, in its as-built configuration, does not satisfy the targeted or required performance objectives it is herein suggested that the retrofit strategy for the building shall comprise of an evaluation of the required variation of the equivalent stiffness of the floor, capable of changing the overall performance. A strengthening technique to achieve such a Delta-stiffness can then be defined.

In other terms, a performance-based retrofit strategy would thus consist of targeting a set of performance objectives (performance level or limit states for a given earthquake intensity or return period) and modify accordingly the hierarchy of collapse mechanism to achieve the targeted capacity and behaviour.

Brittle modes, as for example out-of-plane overturning walls (typically referred to as first mode of failures and caused by either excessive floor and displacement acceleration) can be thus protected by modifying the hierarchy of failure and intervening on the global stiffness of the diaphragms including the connection between floors and walls.

In principle, following the aforementioned procedure and considering the controversial effects that an increase in diaphragm stiffness can lead to, an increase in diaphragm stiffness might not necessarily be the appropriate strategy. The selection of the specific technique and detailing of the intervention, referring to that ones previously presented, should thus follow a clear evaluation of the required diaphragm stiffness, which can be achieved by modifying either the sole diaphragm or the floor-walls connectors, as described in the following paragraphs.

In Figure 13 a flowchart summarizing the retrofit strategy is presented: equivalent stiffness of both diaphragm and connectors ( $k_{eq,c+d}$ ) can be evaluated in the building assessment phase as will be show in the next paragraph. Than considering the seismic behaviour of the building it is possible to determine the target variation of equivalent stiffness ( $\Delta k_{eq,c+d}$ ) in order to have a good global behaviour (referring to the limit States defined by the guidelines) and the desired hierarchy of strength. This way, the choice of the retrofit technique, between that ones previously presented, follows on the knowledge of the target stiffness of the diaphragm, that can be achieved working on the floor or on the connections with the walls.

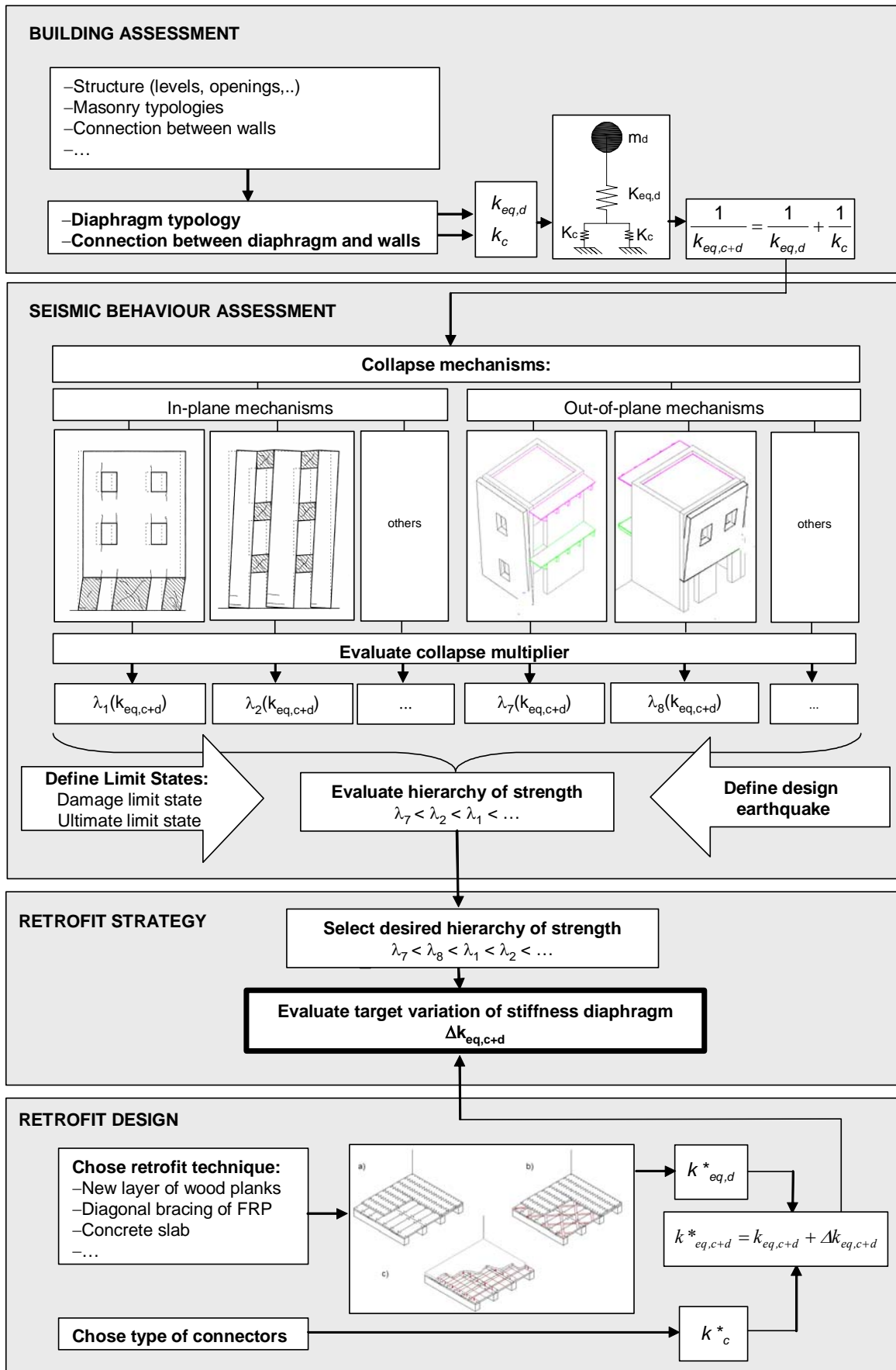

Figure 13. Flowchart on retrofit strategy for timber floor diaphragm.

## 5 EVALUATION OF DIAPHRAGM STIFFNESS

As illustrated in Figure 14 the overall stiffness of the floor unit, which controls the out-of-plane displacement of the wall units, is given by the contribution of the in-plane stiffness of the sole diaphragm ( $k_{eq,d}$ ) and the stiffness of floor-wall shear connectors ( $k_c$ ). The two systems (diaphragm and connectors) are thus in series, the total deformation ( $\delta_{TOT}$ ) of the diaphragm being given by the sum of the two contributions:

$$\delta_{TOT} = \delta_c + \delta_d \quad (1)$$

where  $\delta_c$  = displacement due to stiffness of shear connectors;  $\delta_d$  = displacement due to diaphragm stiffness. In the ideal case of rigid connectors ( $k_c \rightarrow \infty$ ) the overall deformation is only due to the internal diaphragm stiffness. Similarly, when assuming a rigid diaphragm ( $k_{eq,d} \rightarrow \infty$ ), only the connectors stiffness counts. The equivalent stiffness of the floor system ( $k_{eq,c+d}$ ), which ultimately should be used in the assessment, design and retrofit analysis, is thus given by the combination of both contribution as follows:

$$\frac{1}{k_{eq,c+d}} = \frac{1}{k_{eq,d}} + \frac{1}{k_c} \quad (2)$$

Focusing on the diaphragm-only (from here on simply referred to as diaphragm), it is fundamental to be able to evaluate an equivalent stiffness depending on the different typologies available in construction practice before and after the retrofit intervention. In particular for the as-built configurations, analytical procedures are available in literature and are adopted by the international guidelines on the seismic rehabilitation of buildings. In the next paragraph a comparison between some guidelines underline the differences achievable using different approaches.

The prediction of the expected stiffness associated to alternative retrofit solutions is however a more complex task, which requires further information based on both numerical and experimental investigation.

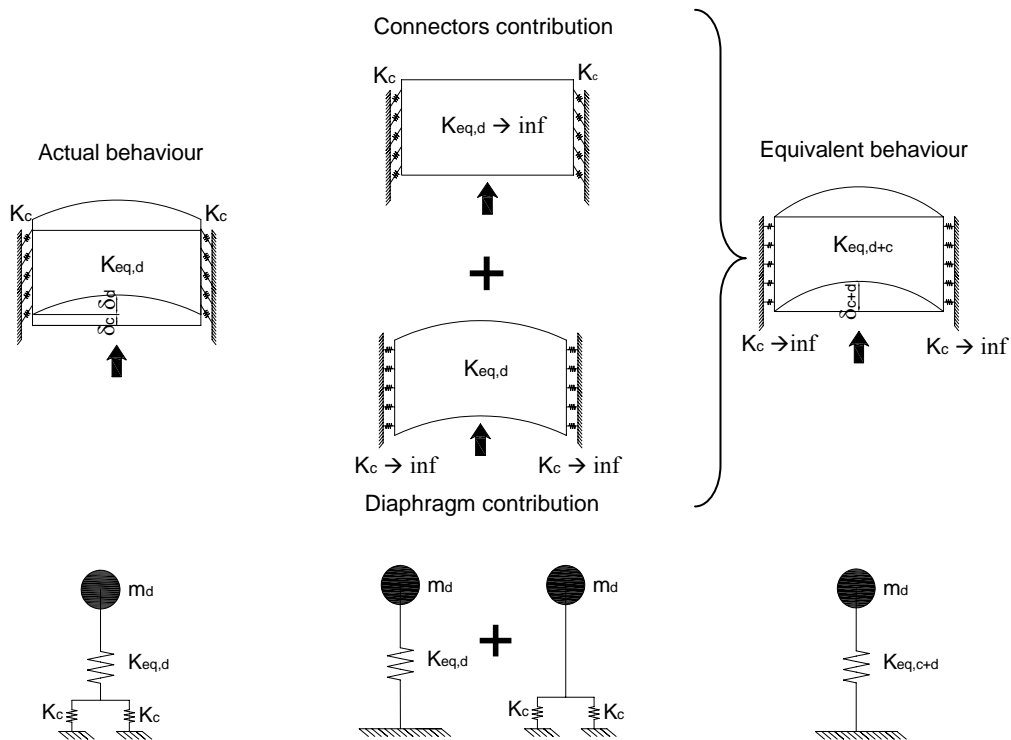

Figure 14. Schematic contributions of connectors and diaphragm stiffness to the overall floor system stiffness.



## 5.1 Analytical evaluation of diaphragm-only stiffness

The diaphragm flexibility can be evaluated by analysing the contribution to the in-plane deformation of the timber floor under simple loading conditions (Fig. 15a). Referring to a single straight sheathing, (typically consisting of 20-50 mm thick and 100-200 mm wide boards) nailed in a single layer at right angles to the cross beams, the overall flexibility can be evaluated by assuming three different contributions (Eq. 3): the flexural deformation of the single board (Fig. 15d), shear deformation of the single board (Fig. 15c) and the rigid rotation of the board due to nails slip (Fig. 15b).

$$\delta = \delta' + \delta'' + \delta''' = \left( \frac{F'}{k_{ser}} \cdot \frac{2}{s_n} + \frac{\chi}{GA} \cdot F + \frac{l^2}{12EI} \cdot F \right) \cdot l \quad (3)$$

where  $F'/k_{ser}$  = nail slip resulting from the shear force  $F$  ( $F \cdot i = 2 \cdot F' \cdot s_n$ );  $k_{ser}$  = nail deformability that can be determined with experimental tests or with some experimental formula provided by some codes (ENV 1995-1-1 2004);  $\chi$  = shear factor;  $G$  = shear modulus of timber planks;  $E$  = flexural modulus parallel to the grain of timber planks;  $A$  = area of plank section;  $I$  = moment of inertia of plank section;  $l$  = wheelbase between beams;  $s_n$  = nails spacing.

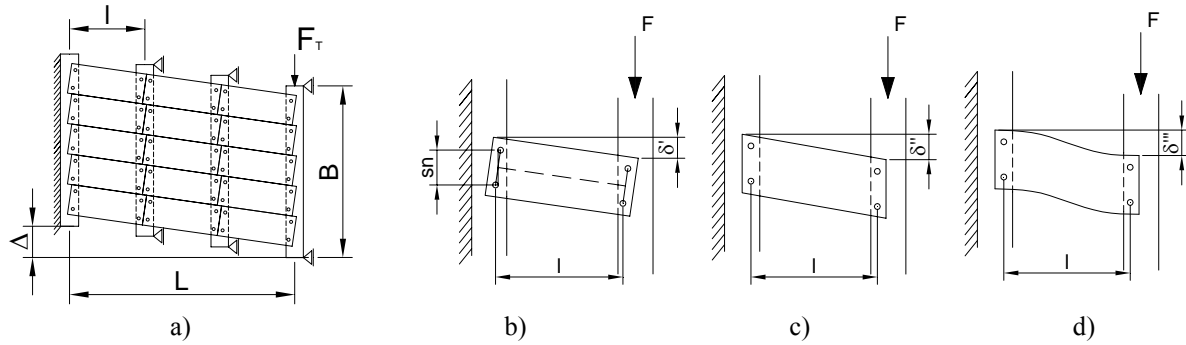

Figure 15. a) In-plane deformation of a single straight sheathing timber floor. Contributions of deformability: b) Rigid rotation of the board due to nails slip; c) board shear deformation; d) board flexural deformation.

Starting from Equation 3 it is possible to define an equivalent shear modulus that combine the three contributions of flexibility. This result obtained for one board can be extended to the whole diaphragm when the wood planks are interrupted at each beam:

$$G_{eq} = \frac{\chi \cdot F_T}{Bt} \cdot \frac{L}{\Delta} = \frac{\chi}{A} \cdot \left( \frac{l}{k_{ser} \cdot s_n^2} + \frac{\chi}{GA} + \frac{l^2}{12EI} \right)^{-1} \quad (4)$$

where  $B$  = total width of the diaphragm;  $t$  = thickness of the boards;  $F_T$  = total shear force on the diaphragm,  $\Delta$  = total displacement of the diaphragm.

This procedure is in general adopted by either FEMA 356 and the NZSEE Guidelines for Assessment of existing buildings (2006) with some differences (Tab. 2): in the NZSEE Guidelines for this type of one-way timber diaphragm, an analytical formula is provided to evaluate the deflection in the mid-span due to the nail slip only (flexural and shear deformation of the board are neglected). In the FEMA 356 guidelines the mid-span deflection is evaluated by directly using an equivalent stiffness provided in a table as a function of the type of floor ( $G_d = 0.35$  KN/mm for a single straight sheathing).

**Table 2. Stiffness and deflection evaluation in NZSEE2006 and FEMA356**

	Deflection in the middle span of diaphragm	Equivalent shear modulus
NZSEE Guidelines	$\Delta_h = \frac{Le_n}{2s} \rightarrow \frac{\Delta}{2} = \frac{LF'}{s_n k_{ser}}$	$\rightarrow G_{eq} = \frac{\chi}{A} \left( \frac{l}{k_{ser} s_n^2} \right)^{-1}$
FEMA 356	$\Delta_y = \frac{v_y \cdot (L/2)}{G_d} \rightarrow \frac{\Delta}{2} = \frac{(F_T / B) \cdot (L/2)}{G_d}$	$\rightarrow G_{eq} = \frac{\chi \cdot G_d}{t}$

where  $\Delta_h = \Delta_y = \Delta/2$  = deflection in the middle of the diaphragm span;  $e_n = F'/(2k_{ser})$  = nail slip;  $s = s_n$  = nails spacing;  $v_y = F_T/B$  = shear for unit width;  $G_d$  = equivalent stiffness.

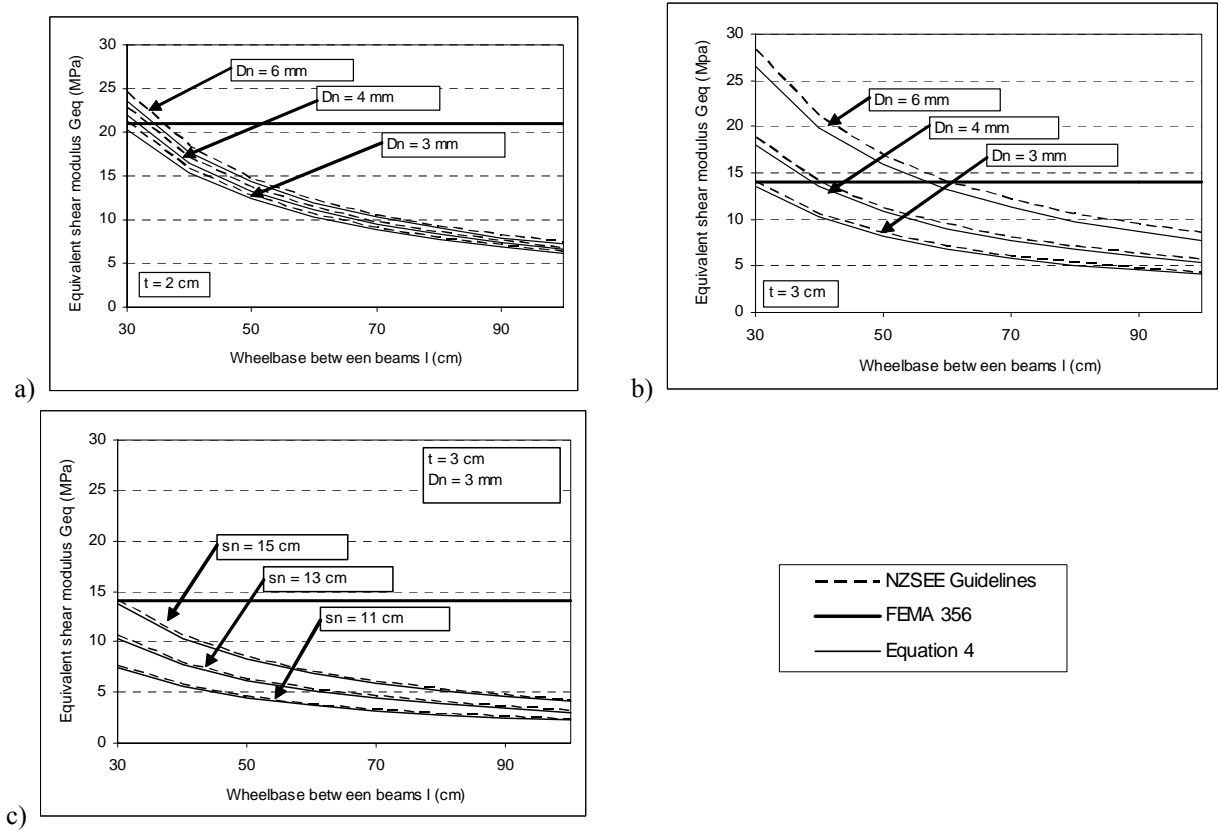

Figure 16. Comparison between equivalent shear modulus  $G_{eq}$  provided by the NZSEE Guidelines, that one given by the FEMA 356 and values obtained using the Equation 4.

a) b) Influence of nails diameter ( $D_n$ ); c) Influence of distance between nails ( $s_n$ ).

In existing timber floors, the disposition of wood planks can have different configurations as shown in Figure 17. In order to prove the validity of the analytical method also if the planks are continuous on the beams joints some numerical analyses using the finite element code ANSYS rel. 8.0 (ANSYS 2003) were performed. The behaviour of a timber diaphragm (3m  $\times$  3m) consisting of 7 wood beams (section 12 cm  $\times$  16 cm, wheelbase 50 cm, span 3 m) and timber planks (section 3 cm  $\times$  20 cm) is modelled using plane elements for the timber planks, beam elements in two dimensions for the wood beams. Link elements, parallel to the planks, are introduced between beam and plank nodes for each nail, together with internal bonds in the orthogonal direction, in order to reproduce the nail slip and to allow for a rigid rotation of the planks. The stiffness related to these elements is calibrated from the force-slip behaviour of the nail ( $k_{ser} = F'/d'$ ) and the design strength of the connector ( $F' = F'_{rd}$ ) (Fig. 18).

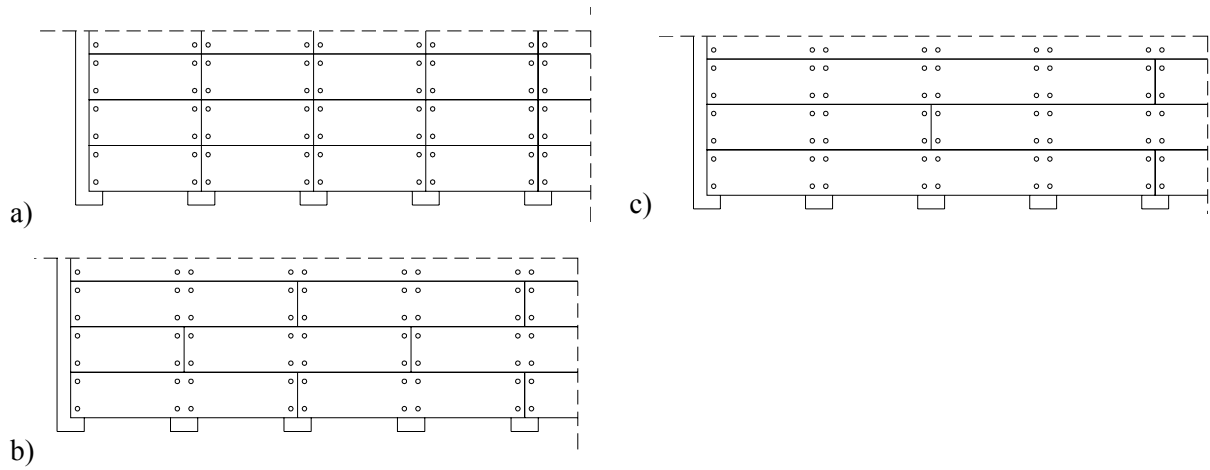

Figure 17. Different dispositions of wood planks: a) Configuration 1; b) Configuration 2; c) Configuration 3.

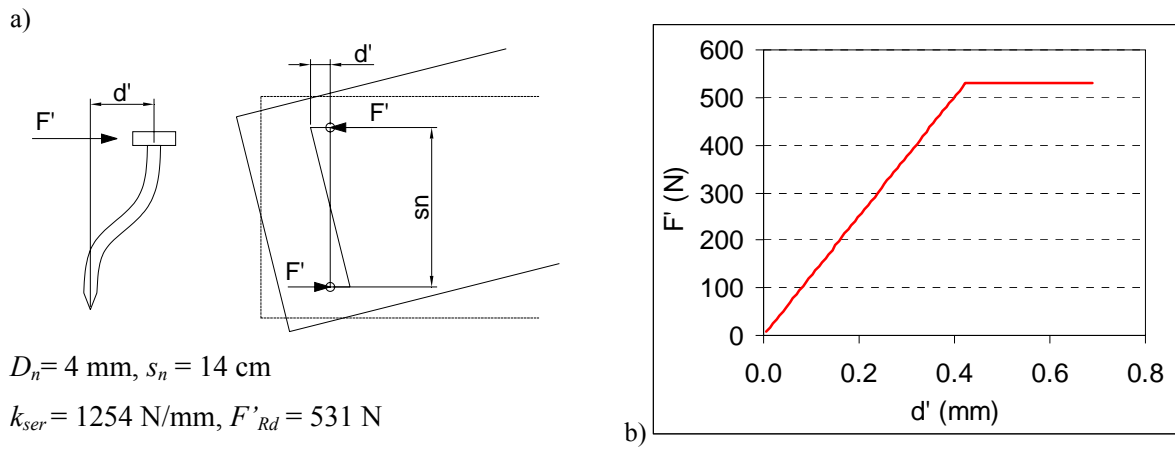

Figure 18. a) Rigid rotation of board due to nails slip; b) force-slip behaviour of nail

The numerical results (Tab. 3) show that the layout configuration does not affect the overall shear modulus (diaphragm stiffness) of the floor. Equation 4 is also well capturing the overall behaviour and, in the absence of more detailed experimental results, can be used to evaluate equivalent shear modulus of this typology of one-way, straight sheathing timber floor.

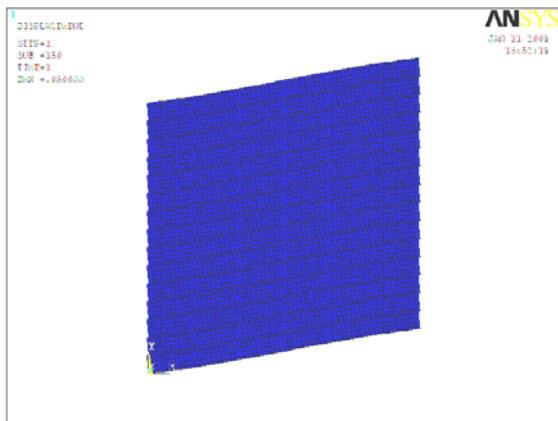

Figure 19. Deformed shape for Configuration 1

Table 3. Comparison between equivalent shear modulus

	$G_{eq}$ (MPa)	$\Delta G_{eq}$ (%)
Equation 4	9.63	0
NZSEE Guidelines	9.83	2.07
FEMA 356	14	45.38
Configuration 1	9.59	-0.40
Configuration 2	9.57	-0.62
Configuration 3	9.55	-0.83

## 5.2 Experimental evaluation of diaphragm stiffness

As mentioned, experimental tests would be critical to validate the in-plane stiffness values obtained by the analytical or numerical models described in the previous paragraphs.

Only few and very recent tests are available in literature on the in-plane behaviour of as-built unreinforced or retrofitted timber floors: some tests were carried out in USA (Peralta et al. 2003) and in the last years some others were performed in Italy, as part of a triennial project of The University Network of Seismic Engineering Laboratories (ReLUIIS-DPC 2005-2008) promoted by the Italian Civil Defence experimental and numerical researcher (Piazza et al. 2008, Corradi et al. 2006). Different test set-up, diaphragm typologies and retrofit techniques were adopted, which complicates the possibilities to compare the experimental results.

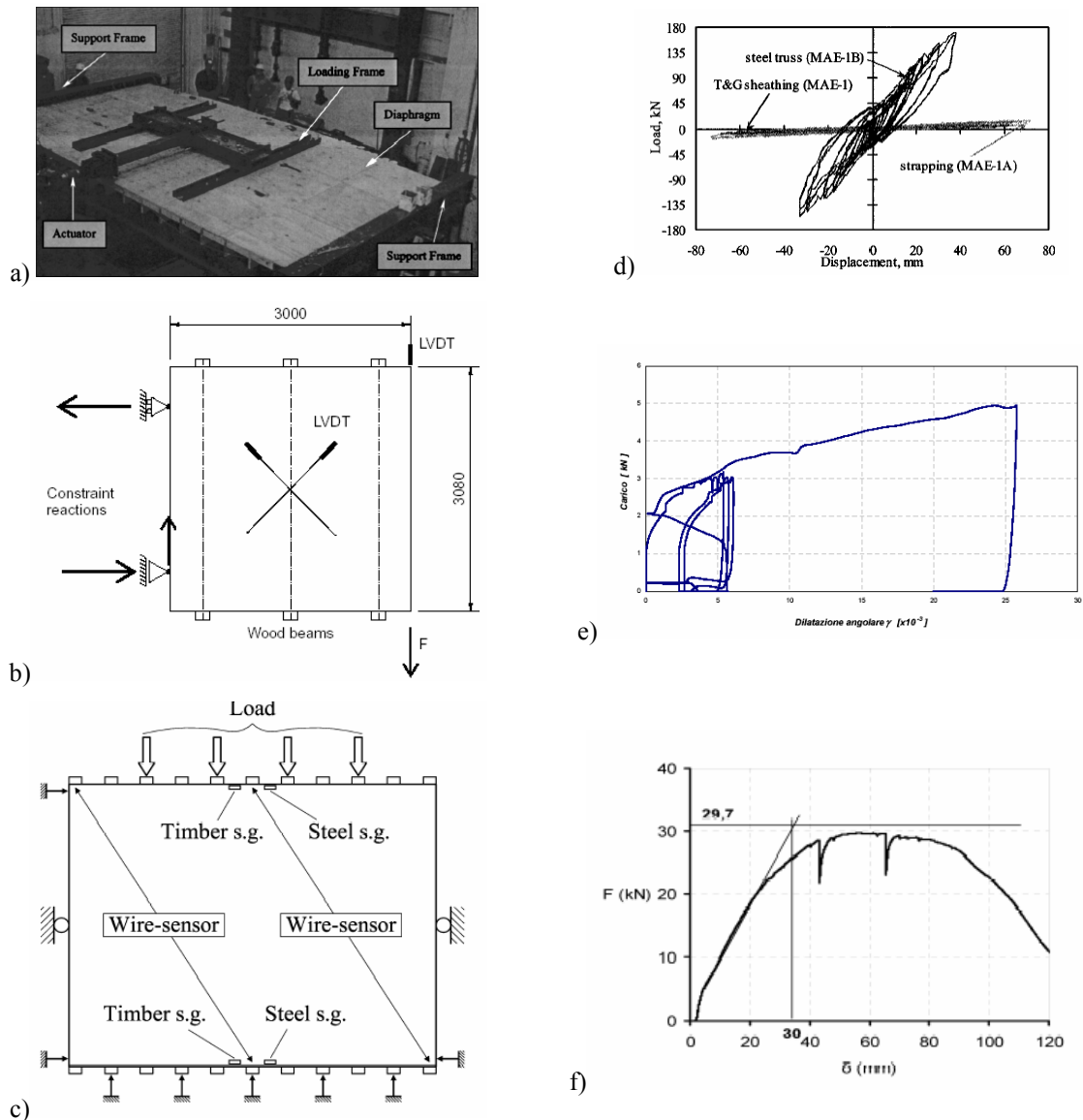

Figure 20. Experimental tests on as-built and retrofit timber floor.

a) Peralta et al. 2003; b) Corradi et al. 2006; c) Piazza et al. 2008; Test results for single straight sheathing diaphragm: d) Peralta et al. 2003; e) Corradi et al. 2006; f) Piazza et al. 2008.

In the tests carried out in Texas (Peralta et al. 2003) the diaphragm specimens were composed of wood elements (one-way) and were 7.32m x 3.66 m in plan (aspect ratio equal to 2). Two steel frames provided gravity and lateral support along the short edges of the specimens parallel to loading direction (Fig 20a). Lateral displacements were applied using one actuator connected to a H-shaped steel loading frame attached at the third points along the diaphragm width. The response of the



specimen was monitored during the test with 12 displacement transducers (LVDTs) and four strain gauges. Most of the instruments were located along the long side of the diaphragm opposite to the actuator location. Specimens were tested under quasi-static reversed cyclic loading.

In Perugia (Corradi et al. 2006) two-way (cross bonded) floors (3m x 3m, aspect ratio equal to 1) were tested. The specimens were anchored to a perimetral steel structure made of L-shaped steel profiles connected to one another by means of four cylindrical hinges (Fig 20b). In the horizontal plane, the frame was constrained using metal anchorages connected to the laboratory walls and floor. The load system was composed of a hydraulic jack placed so that it applied a force acting on the steel structure in the plane of the floor in two different directions: parallel and perpendicular to the wood beams. Three inductive traducers (LVDTs) were applied to each floor sample: two laid along the two diagonals and the third in the direction of the applied shear force. Cyclic test were carried out.

In Trento monotonic tests on small size floor specimen (1 m x 2 m) and cyclic tests on real size floor specimens (one-way, 4m x 5m, aspect ratio equal to 1.25) were performed (Piazza et al. 2008). The floor specimen was linked to the laboratory reaction floor by means of two external hinges (Fig. 20c ). The hinges are positioned centrally, at the neutral axis level in order to allow free in-plane deformation of the diaphragm. A uniformly distributed horizontal action should be applied to the floor under experimentation in order to reproduce the transmission of seismic forces through the floor.

Observing the experimental results (Fig. 20d, 20e, 20f) it is worth noting that, due to the non-linear response of the diaphragm shear force vs displacement (or diagonal deformation), the value of in-plane-stiffness derived by each test is strongly affected by the definition of the floor stiffness adopted. A proper evaluation of the stiffness to be adopted in the analysis of the overall building is of critical importance for both as-built and retrofitted configuration. Alternative approaches have so far being adopted, as summarized in Figure 21, where a generic experimental curve is used. Initial elastic stiffness related to the first part of the curve or a secant stiffness at 1/3 of the maximum load (Corradi et al. 2006) or secant stiffness obtained by equivalent areas (OPCM 2006). Referring to a generic experimental curve it is possible to note that depending on different definitions of stiffness we can find very different values.

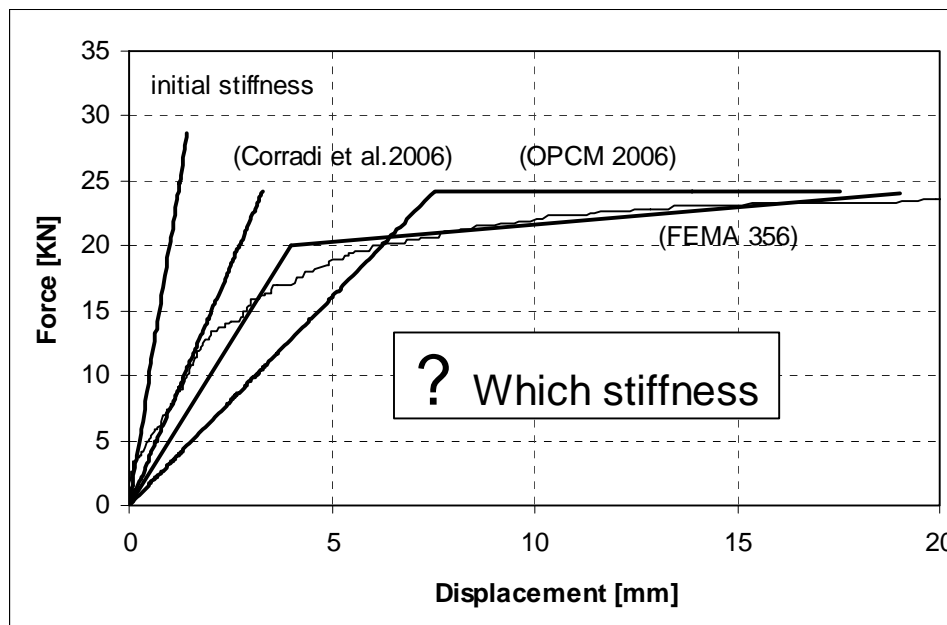

Figure 21. Alternative definition of in-plane timber floor stiffness from experimental tests.

## 6 CONCLUSIONS

In this contribution, a summary of the state-of-the-art related to the role of the in-plane stiffness of timber floors in the seismic response of un-reinforced masonry buildings is presented and critically

discussed based on limited available experimental and numerical evidence.

A framework for a performance-based assessment and retrofit strategy, capable of accounting for the effects of flexible diaphragm on the response prior and after the retrofit intervention, is then proposed: by controlling the in-plane stiffness of the diaphragm, adopting a specific strengthening (or weakening) intervention, displacements, accelerations and internal forces demand can be maintained within targeted levels, in order to protect undesired local mechanisms and aim for a more appropriate hierarchy of strength within the whole system.

The need to define and adopt an adequate testing set-up and loading protocol to be used as a benchmark for the evaluation of the stiffness of timber floors before and after alternative retrofit interventions has been highlighted. As a part of a joined project between the University of Canterbury and the University of Genoa, comprising of experimental and numerical investigations, quasi-static cyclic tests are being prepared for different diaphragm configuration and typologies.

It is worth noting that the proposed procedure to evaluate the in-plane stiffness of timber diaphragms and the effects of an overall seismic response can be adopted for the design of new buildings systems e.g. seismic resisting timber system construction.

#### REFERENCES:

- ABK, A Joint Venture, 1981. Methodology for the mitigation of seismic hazard in existing un-reinforced masonry buildings: diaphragm testing. ABK Tech. Rep. 03, El Segundo, California.
- ABK, A Joint Venture, 1984. Methodology for the mitigation of seismic hazard in existing un-reinforced masonry buildings: the methodology. ABK Tech. Rep. 08, El Segundo, California.
- American Society of Civil Engineers (ASCE), 2000. Pre-standard and commentary for the seismic rehabilitation of buildings. *FEMA Publication 356, Federal Emergency Management Agency, Washington, D.C.*
- American Society of Civil Engineers (ASCE), 1998. Handbook for the Seismic Evaluation of Buildings-A Pre-standard. *FEMA Publication 310, Federal Emergency Management Agency, Washington, D.C.*
- ANSYS User's Manual for Revision 8.0, 2003. ANSYS Inc., Houston, USA.
- Cohen, G.L., Klingner, R.E., Hayes, Jr.J.R. & Sweeney, S.C. 2004a. Seismic evaluation of low-rise reinforced masonry buildings with flexible roof diaphragms: I. Seismic and quasi-static testing. *Earthquake Spectra*. 20 (3): 779-801.
- Cohen, G.L., Klingner, R.E., Hayes, Jr.J.R. & Sweeney, S.C. 2004b. Seismic evaluation of low-rise reinforced masonry buildings with flexible roof diaphragms: II. Analytical modelling. *Earthquake Spectra*. 20 (3): 803-824.
- Cohen, G.L., Klingner, R.E., Hayes, Jr.J.R. & Sweeney, S.C. 2006. Seismic Evaluation of Low-Rise Reinforced Masonry Buildings with Flexible Diaphragms: III. Synthesis and Application. *Earthquake Spectra*. 22 (2): 329-347.
- Corradi, M., Speranzini, E., Borri, A., Vignoli, A., 2006. In-plane shear reinforcement of wood beam floors with FRP. *Composites Part B*, 37: 310-319.
- CNR, 2005. CNR-DT 201/2005, Preliminary studies for the editing of Instructions for Design, Execution and Control of Static Retrofit of Timber Structures using cFRP, Rome. (in Italian)
- CNR, 2006. CNR-DT 206/2007, Instructions for Design, Execution and Control of Timber Structures, Rome. (in Italian)
- De Benedictis, R., De Felice, G., Giuffrè, A., 1993. Anti-Seismic renewal of a building. In Giuffrè (ed), *Safety and Preservation of historical city centre*. Editrice Laterza, Bari. (In Italian).
- Dogliani F., 2000. Handbook (guidelines) for the design of adjustment interventions, seismic strengthening and renewal of architectural treasures damaged during the Umbria-Marche earthquake in 1997. Official Bulletin of Marche Region, Ancona. (in Italian).
- ENV 1995-1-1, 2004. Eurocode 5. Design of Timber Structures. Part 1-1: General Rules and Rules for Buildings, CEN European Committee for Standardization, Bruxelles.
- Galasco, A., Lagomarsino, S., Penna, A.. 2001, TREMURI Program: Seismic Analyser of 3D masonry buildings.

- Gattesco, N., Macorini, L., 2006. Strengthening and Stiffening Ancient Wooden Floors with Flat Steel Profiles, in Lourenco, P.B., Roca P., Modena C., Agrawal S. (ed.), *Structural Analysis of Historical Constructions*; Proc. Int. Conf., New Delhi, 6-8 November 2006, New Delhi: Macmillan.
- Gattesco, N., Macorini, L., Benussi, F. 2007. Retrofit of wooden floors for the seismic adjustment of historical buildings with high reversible techniques. *Seismic Engineering in Italy*; Proc. Of the XII National Conference, Pisa, 10-14 June 2007, full paper on CD (in Italian).
- Giuriani, E., Marini, A. & Plizzari, G. 2002. Shear behaviour of wooden floors strengthened by stud connected wooden planks, Technical Report n. 7, Department of Civil Engineering, University of Brescia.
- Lagomarsino, S. & Podestà, S. 1999. Methodologies for the vulnerability analyses of churches. *Seismic Engineering in Italy*; Proc. Of the IX National Conference, Turin, 20-23 September 1999, Turin (Medi@SOFT), (in Italian).
- OPCM 3274, 2005. Code for the seismic design, assessment and retrofitting of buildings (Appendix 2). Ordinance of the Prime Minister, n. 3274 (20 March 2003) modified by n. 3431 (3 May 2005). (in Italian).
- NZS 1170.5:2004 - Structural Design Actions - Part 5 : Earthquake actions – New Zealand.
- Paquette, J. & Bruneau, M. 2006. Pseudo-dynamic testing of un-reinforced masonry building with flexible diaphragm and comparison with existing procedures. *Constructions and Building Materials* 20: 220-228.
- Peralta, D. F., Bracci, J. M. & Hueste, M. D. 2003. Seismic performance of rehabilitated wood diaphragms, Mid-America Earthquake Centre, University of Illinois at Urbana-Champaign, CD Release 03-01.
- Peralta, D. F., Bracci, J. M., & Hueste, M. B. D. 2004. Seismic behaviour of wood diaphragms in pre-1950s un-reinforced masonry buildings. *Journal of Structural Engineering*, 130(12): 2040-2050. Retrieved January 31, 2008, from Earthquake Engineering Abstracts database.
- Piazza M., Baldessari C., Tomasi R., Acler E., 2008. Behaviour of refurbished timber floors characterized by different in-plane stiffness. Private communication.
- Recommendations of a NZSEE Study Group, 2006. Assessment and Improvement of the Structural Performance of Buildings in Earthquake.
- Tena-Colunga, A. 1992. Seismic evaluation of un-reinforced masonry structures with flexible diaphragms, *Earthquake Spectra*, 8(2): 305-318.
- Tena-Colunga, A., Abrams, D.P. 1995. Simplified 3-D Dynamic Analysis of Structures with Flexible Diaphragms, *Earthquake Engineering and Structural Dynamics*, 24(2): 221-232.
- Tena-Colunga, A., Abrams, D.P. 1996. Seismic Behaviour of Structures with Flexible Diaphragms, *ASCE Journal of Structural Engineering*, 122(4): 439-445.
- TREMA Project, Technologies for the Reduction of seismic Effects on Architectural Manufactures 2006, [www.unibas.it/trerem/index.htm](http://www.unibas.it/trerem/index.htm)