

How mosquito-eating jumping spiders communicate:
complex display sequences, selective attention
and cross-modality priming

A thesis
submitted in partial fulfilment
of the requirements for the Degree
of
Master of Science in Zoology
in the
University of Canterbury
by
Fiona Ruth Cross

University of Canterbury

2003

CONTENTS

Abstract	1
Chapter 1: Introduction	2
Chapter 2: Display and mating behaviour of <i>Evarcha culicivora</i>, a jumping spider (Araneae: Salticidae) from East Africa	21
Chapter 3: The influence of body size in the mate-choice decisions of <i>Evarcha culicivora</i>, a mosquito-eating jumping spider (Araneae: Salticidae) from East Africa	76
Chapter 4: Odour-mediated decisions by <i>Evarcha culicivora</i>, a mosquito-eating jumping spider (Araneae: Salticidae) from East Africa	89
Chapter 5: Cross-modality priming effects of conspecific, prey and plant odour on the mate-choice behaviour of <i>Evarcha culicivora</i>, a mosquito-eating jumping spider (Araneae: Salticidae)	122
Chapter 6: Discussion	137
Acknowledgements	154

ABSTRACT

Evarcha culicivora is a salticid with an unusual preferred diet (vertebrate blood obtained indirectly by preying on female mosquitoes that have themselves had recent blood meals) and an unusual affinity for particular plant species (*Lantana camara* and *Ricinus communis*). This thesis is a study of how individuals of this species interact with each other, with a general objective being to clarify the role of visual attention and cross-modality priming in the mate-choice behaviour of this species. *E. culicivora*'s courtship and display behaviour was shown to be especially complex and highly variable. Experiments on vision-based mate-choice showed that mutual mate-choice behaviour is pronounced in *E. culicivora* and that both sexes prefer large mates over small mates. Olfactometer experiments showed that *E. culicivora* is attracted to the odours of blood-fed female mosquitoes, *Lantana camara* and *Ricinus communis* and opposite-sex conspecifics. A prior diet of blood-fed female mosquitoes enhances attractiveness to the opposite sex. Opposite-sex conspecifics paired with the odour of blood-fed female mosquitoes are also more attractive. Cross-modality priming effects were investigated in other experiments that showed individuals of *E. culicivora* responded more to visual cues of opposite-sex conspecifics when in the presence of certain odours (of opposite-sex conspecifics, blood-fed female mosquitoes and *L. camara*).

CHAPTER 1

INTRODUCTION

This thesis is a study of the courtship and mate-choice behaviour of *Evarcha culicivora*, an East African jumping spider (Araneae, Salticidae) from the Lake Victoria region of Kenya and Uganda (Wesolowska & Jackson, 2003). In a family known for garish display of colour, *E. culicivora* may at first glance not look especially interesting. Although adult males of *E. culicivora* have distinctive blood-red faces, adult females and juveniles of both sexes have grey-brown bodies and faces. Nor is it unusual in size. Adults are about 6 mm in body length, and spiderlings are about 1.5 mm in body length after hatching, which is more or less typical for salticids.

However, appearance can be deceiving. It is *E. culicivora*'s behaviour that sets it apart. As its name acknowledges, *E. culicivora* eats mosquitoes. In particular, by choosing as preferred prey blood-fed female mosquitoes, this spider uses the mosquito as an indirect way to feed on vertebrate blood. This makes it unique not only among salticids but also among all known predators. That is, this is the first predator of any kind to be shown to seek out mosquitoes as preferred prey (Pain, 2002). However, there may be other links between *E. culicivora* and mosquitoes, and some of these are especially surprising. For example, preliminary research has suggested that odours from *E. culicivora*'s preferred prey, blood-fed mosquitoes, influence this spider's courtship and mate-choice behaviour (Pain, 2002), and nothing like this has ever been reported before. This became the initial rationale for my thesis, with an important first step being to get

detailed information about *E. culicivora*'s courtship and mate-choice behaviour before moving on to experimental work.

In surprising ways, a study of this spider's courtship and mate-choice behaviour converges with a broader interest of mine, animal cognition. Animal cognition has been a long neglected field in biology and psychology, but it has been steadily gaining standing (Yoerg, 1991; Kamil, 1998). In the 20th century, two traditions dominated the study of animal behaviour, ethology and comparative psychology, with ethology placing more emphasis on ultimate causation (Morgan, 1896) and comparative psychology placing more emphasis on proximate causation (Watson, 1919). Early on, both of these traditions more or less explicitly excluded cognition from their theoretical frameworks (Boakes, 1984; Richards, 1987; Mazur, 1998). However, research on animal cognition appears to be generating a new framework that adds a perspective that was missing in these two dominant frameworks of the 20th Century (Shettleworth, 2001).

Discussing spider cognition may appear especially unusual since birds and mammals are the animals typically considered to be appropriate subjects for research on cognitive processes. Yet there is already considerable precedence for using insects as subjects in cognitive studies (e.g. Dukas & Visscher, 1994), and spiders from the family Salticidae appear to be especially suitable for research on cognition because of their complex, flexible behaviour (Jackson & Wilcox, 1998; Wilcox & Jackson, 2002). What is more, salticids seem to be especially suitable arthropod subjects for research on vision-based cognition because they have unique, complex eyes and visual acuity that is greater than that of any other animal in their size range (Harland & Jackson, 2000; Land & Nilsson, 2002). Being able to see so well, jumping spiders readily perform feats of fine-

grained discrimination between different kinds of prey (Jackson & Pollard, 1996; Harland & Jackson, 2001).

Fine-grained visual discrimination might also be expected in salticid mate-choice behaviour, but relatively little experimental work has been undertaken to look specifically at the visual-discrimination processes, much less the cognitive processes, underlying salticid courtship. One of the most distinctive things about salticid courtship is its complex, highly variable character (Jackson & Pollard, 1997). The male and the female both adopt a number of different behaviour patterns, combine these into a bewildering variety of sequences and generally defy attempts to reduce what happens to any simple description. The complexity of salticid courtship sequences, along with the details of some of the individual displays used by salticids, suggests the way I decided to combine my interest in salticid courtship display with studying cognition. I wanted to investigate whether studying salticid courtship might be instructive for understanding selective visual attention and attentional priming, including cross-modality priming.

Visual attention is an important topic in human cognitive psychology, but not a routine topic in the study of animal cognition (Dukas, 2002). One problem is how difficult it is to define or explain visual attention (Pashler, 1998), but the principal idea may be appreciating that, for an animal, all sensory input is not equal. That is, the animal can be thought of as picking out important information from the environment, and more or less ignoring the unimportant information (Palmer, 1999). Perhaps the simplest example from salticid courtship is something many spider researchers have probably seen, but never studied in detail. When a salticid female is watching a male's courtship display, she is highly responsive to the movements of the male, and much less responsive

to other features of her surrounding environment, including passing insects. When a person stages salticid male-female encounters, great care is usually needed to avoid making hand and body movement to which the salticids might respond, but careless movement seems almost irrelevant once courtship has begun. My working hypothesis is that evidence of selective attention will be especially pronounced in salticid courtship. The rationale for this hypothesis is appreciating that attention seems to be computationally demanding even for much larger animals such as humans and other vertebrates (Dukas & Kamil, 2000). Scaling factors might make attention dramatically more demanding for an animal with a much smaller brain, namely a salticid.

Priming can also be difficult to explain, but the idea behind what is happening is that exposure to some particular stimulus causes an expectation of encountering some other particular stimulus (Anderson, 2000). Most priming studies have been with human subjects (e.g. Meyer & Schvaneveldt, 1971) and, to a lesser extent, other vertebrates (e.g. Blough, 1989). What has typically been examined is priming by one vision-based stimulus of selective attention to some other vision-based stimulus. Evidence of priming might be faster response to the second stimulus when exposure to this stimulus has been preceded by some particular other stimulus. For example, Meyer and Schvaneveldt (1971) found that participants were faster to respond to related pairs of words (e.g., faster to respond to “nurse” when seeing the word “doctor”) than to unrelated pairs of words (e.g., “bread” preceded by “doctor”). Priming experiments are important because they demonstrate that the associative strength between two stimuli affect the way an organism responds. This requires an understanding that goes beyond the stimulus-response chains

that seemed to be the expectation in much of the history of both ethology and operant psychology.

Preliminary work has suggested that priming may be relevant to *E. culicivora*'s courtship, and probably to salticid courtship generally. However, I decided that *E. culicivora*'s courtship might be useful for investigating not only *attentional priming* but also *cross-modality priming* effects in particular. One way of interpreting attentional priming is that it occurs when a specific cue activates in an animal a mental representation of a target (e.g., a potential mate) and this representation then helps the animal to prepare for detecting the target before actually encountering it (Blough & Blough, 1997). Cross-modality priming is where a cue in one modality (e.g., olfaction) causes attentional changes in another modality (e.g., vision). For example, cross-modality priming might occur when detecting a particular odour cue prepares an animal for detecting a particular visual cue. There have been only a few studies of cross-modality priming effects in humans (Pauli et al., 1999; Driver & Spence, 1999; Stein et al., 2001) or other animals (Martin-Malivel & Fagot, 2001). However, the relevance of cross-modality priming to salticids has been shown in the context of prey detection. *Portia fimbriata* is a salticid that preys by preference on other spiders. Olfactory and contact-chemical cues from a particular prey-spider species, *Jacksonoides queenslandicus*, prepare *P. fimbriata* for encounters with this particular prey species (Jackson et al., 2002): *P. fimbriata* responds faster to optical cues from *J. queenslandicus*, but not other prey, when the odour of *J. queenslandicus* (but not the odour of other prey) is also present. Similar cross-modality effects have been shown in salticids that specialise at feeding on ants (Clark et al., 2000). This evidence from salticid predatory behaviour is

encouraging because it shows at least that the computational ability required for cross-modality priming is achievable by a small salticid brain.

My interest is in whether cross-modality priming is important in a different context, mate-choice behaviour rather than predatory behaviour. However, my interest differs from that in the earlier studies on spider-eating and ant-eating salticids in another way. In the earlier studies, the odour and the visual cues both came from the same source (particular prey species) and both were readily understood in the same context (prey detection). My research objective is different because, in addition to investigating cross-modality priming in what may appear clearly to be the same context (i.e., odour of potential mates priming attention to optical cues from potential mates), I examine something less straightforward: whether response to visual cues that come from potential mates is primed by olfactory cues that come not from potential mates but instead from sources that seem to make sense (to us) in a different context.

One of the bigger practical advantages that comes from using salticids in research on visual cues is that the extraordinary eyesight of these spiders means we can do experiments in which the *potential mate* presented to a living test spider is a mount instead of another living spider. When using living spiders, the way the two spiders interact quickly complicates data interpretation, but this complication is eliminated when using motionless mounts (i.e., dead individuals of *E. culicivora* of specified size positioned in specified posture on a cork disc). Odour cues from the mount itself can be eliminated by prior washing in ethanol. This means that I can decide what odour cues to make available during experiments. I use three sources of these odour cues. One of these (odour of another conspecific salticid) may have obvious relevance to mate-choice, but

the relevance of the other two is not immediately obvious (odour from the preferred prey and odour from particular plant species). Many salticids are known to feed on nectar (Jackson et al., 2001), but nothing is known about how any salticid species responds to plant odours. However, my interest is not simply in how *E. culicivora* responds to plant odours and not specifically plant-odour response in the context of feeding. What I investigate is something less obvious (i.e., how plant odour affects mate-choice decisions). Two plant species from *E. culicivora*'s habitat, *Ricinus communis* and *Lantana camara*, are of particular interest.

Ricinus communis is native to East Africa where it can grow to a height of 3 m (Parsons & Cuthbertson, 2001). This attractive plant with reddish-green flowers is commonly known as the castor-oil plant. *Lantana camara*, which may also grow to 3 m in height (Parsons & Cuthbertson, 2001), is common in *E. culicivora*'s habitat, but this species is probably of West Indian origin (Schemske, 1983). Although *L. camara* might most appropriately be envisaged as a weed in *E. culicivora*'s habitat, there are other species of *Lantana* that are native to East Africa. *L. camara* seems to be displacing the native species, and my working hypothesis is that adaptations *E. culicivora* might have evolved with native *Lantana* are now being expressed with *L. camara*.

There is another reason why *E. culicivora* is of special interest. As the first predator ever to be shown to single out female mosquitoes as preferred prey, *E. culicivora* is a potentially beneficial species. For my thesis, this interest lies in the background, but it is something that makes almost anything we might learn about this species unusually interesting.

Female mosquitoes matter to people because they are vectors of some important disease organisms. Malaria is the most notorious mosquito-carried disease, and malaria is especially serious in East Africa, the very area that *E. culicivora* makes its home. Malaria is caused by *Plasmodium*, a genus of single-cell parasites that feed on haemoglobin from vertebrate red-blood cells. Many reptiles, birds, and mammals have their own versions of malaria (Spielman & D'Antonio, 2001). Four species of *Plasmodium* cause human malaria, but *P. falciparum* is by far the most dangerous. *P. falciparum* is especially prevalent in sub-Saharan Africa. Female mosquitoes are the vectors that carry *Plasmodium* from one person to the next. All human malaria vectors belong to one mosquito genus, *Anopheles*. The world's most efficient vector of human malaria is *Anopheles gambiae* (Spielman & D'Antonio, 2001) and this species is native to equatorial Africa. Two things in particular explain *A. gambiae*'s effectiveness as a vector for *P. falciparum*: it has an especially long lifespan for a mosquito, and it is anthropophilic (i.e., it feeds almost exclusively on people).

Anopheles gambiae is often referred to as the most dangerous insect on Earth (Miller & Greenwood, 2002), and the brain-numbing statistics on malaria show why. Every year something like 400 million people fall ill with malaria, and 1–3 million of these people die, mainly children aged under 5 years, and mainly in Africa (Marshall, 2000). A number of large-scale measures have been taken to reduce the impact of malaria, including subsidising availability of pesticide-treated mosquito nets (e.g. Vogel, 2002), development of antimalarial drugs in a race to keep ahead of *Plasmodium*'s ability to evolve resistance (e.g. Miller & Greenwood, 2002), attempting to develop a malaria vaccine (Taubes, 2000), and even attempts to engineer a malaria-resistant mosquito to

replace natural populations (Enserink, 2000). In 1998, the World Health Organisation (WHO) announced its Roll Back Malaria (RBM) scheme, the stated goal being to halve the rate of mortalities caused by malaria by 2010 (Balter, 2000), but it is widely recognised that no one measure will be a magic bullet with which we will win the fight against malaria.

It will be welcome news if *E. culicivora* has even a modest role in malaria control, and recent discoveries are encouraging. The newly-hatched juveniles of *E. culicivora*, only 1.5 mm in body length, apparently hunt *Anopheles* mosquitoes as preferred prey (Jackson, unpublished data). That these minute juveniles can take down an *Anopheles* at all is remarkable, but *Anopheles*' posture makes a difference. Unlike other mosquitoes, *Anopheles* mosquitoes rest with their abdomens tilted up. The small *E. culicivora* juvenile sees well enough to discern the mosquito's posture and then moves behind the mosquito and attacks it from underneath (Pain, 2002). Adults of *E. culicivora* feed on many kinds of mosquitoes, including *Anopheles* mosquitoes, and they may kill up to 20 blood-fed mosquitoes in rapid succession when they smell blood (Pain, 2002). This suggests that the smell of blood primes *E. culicivora* to become selectively attentive to the visual cues from its mosquito prey.

In *E. culicivora*'s habitat, finding mosquitoes may challenge *E. culicivora*'s perceptual abilities because of the prevalence of other similar-sized insects known by Kenya locals as 'lake flies.' Lake flies form in huge swarms (numbering in the millions) above Lake Victoria (Okedi, 1992) and rain down on the shoreline vegetation and human dwellings. Lake flies are mainly dipterans from the families Chironomidae and Chaoboridae, along with mayflies, especially *Povilla adusta* (Ephemeroptera).

Mosquitoes form a small minority in these masses of other small insects, yet *E. culicivora* is remarkably good at picking a mosquito out of a crowd (Pain, 2002).

Priming of selective attention may be an important factor behind *E. culicivora*'s success as a mosquito predator. However, my objective is to consider something less straightforward: that odours from preferred prey influence *E. culicivora*'s courtship and mate-choice behaviour. The types of influences I consider lead stepwise to priming, but I begin by investigating influences that are not so clearly cognitive. First, I consider whether odour from mosquito-derived blood and odour from particular plants (*R. communis* and *L. camara*) make *E. culicivora* males more attractive to *E. culicivora* females and *E. culicivora* females more attractive to *E. culicivora* males. I also investigate whether *E. culicivora* uses *R. communis* and *L. camara* as mating sites (i.e., as places to gather for courtship and mating).

The rationale for experiments on priming by plant odour is derived from this more basic work on how the plants are integral to *E. culicivora*'s mating system. However, something more basic is needed as a preliminary to the various experimental studies, and this is the largest, most demanding part of the thesis. It sounds so simple. Before experimentally studying the factors that influence *E. culicivora*'s courtship and mate-choice decisions, it would be good to know how individuals of this species interact with each other. This is the objective of Chapter 2. I know it is not quite as simple as it sounds because all salticids have exceptionally complex display repertoires (e.g. Jackson & Pollard, 1997). However, I also appreciate that *E. culicivora* is extreme even for a salticid. Chapter 2, the background information needed for developing the subsequent chapters, is a challenge because *E. culicivora* apparently has the most complex and

variable display repertoire ever described for a spider, and one of the most complex known for any animal species other than our own.

Chapter 3 is an experimental study of some basic questions about *E. culicivora*'s mate-choice decisions. There appear to be many animals that base mate-choice decisions on comparing body sizes of potential mates (e.g. Bonduriansky & Brooks, 1998), generally with the preferred mates being larger (Andersson, 1994). In *E. culicivora*, body size is influenced by diet (Jackson, unpublished data), with feeding on blood derived from mosquitoes enabling males and females to reach larger body size. I investigate whether larger individuals are preferred as mates because this might be a step toward explaining *E. culicivora*'s unusual feeding behaviour and prey choice. I also want to determine whether *E. culicivora* can make size-related mate-choice decisions by using visual cues alone and whether mate-choice behaviour is strongly expressed in females alone, in males alone, or in both sexes. Trivers (1972) argued that differences between the sexes in the degree of parental investment has shaped the prevalent sex roles seen in nature, and Trivers (1972) explained why it is often the case that females benefit more than males by being selective of mates and why males often benefit more than females by being less discriminating. Subsequent to Trivers (1972), the mate-choice literature often appeared to argue something more simplistic than in Trivers' (1972) original formulation: that the prevalent pattern is for one sex (usually the female) to be selective, and the other sex to be indiscriminate in mate-choice situations (see Wagner, 1998). Recent studies (Altmann, 1997; Bonduriansky, 2001; Gowaty et al., 2003; Drickamer et al., 2003) are suggesting that it may often be the case that male mate-choice and female mate-choice

are both pronounced in the same species. I will be examining mutual mate-choice in *E. culicivora*.

Chapter 4 is an experimental study of some basic questions about *E. culicivora*'s responses to olfactory cues from blood-fed females of *Anopheles* mosquitoes and from particular plant species. The first step is to ascertain whether, in tests during which *E. culicivora* can approach an odour source, *E. culicivora* distinguishes between mosquitoes that have and have not fed on blood and between different plant species, my hypotheses being that *E. culicivora* has a preference for the odour of blood-fed mosquitoes and the odour of *L. camara* and *R. communis*. The second step is to consider how these basic odour preferences might influence mate-choice decisions. For this, I chose only one of the two plant species (*L. camara*) because there was insufficient time to use both. My hypothesis is that the odour of mosquito-derived blood and the odour of *L. camara* make individuals of *E. culicivora* more attractive as potential mates, independent of size preference.

Chapter 5 is an experimental study where implications about selective attention and cross-modality priming are considered more directly in the context of male-female interaction. First, I consider something more or less straightforward on cross-modality priming. I examine whether *E. culicivora*'s ability to locate a potential mate is enhanced by olfactory cues from potential mates. In these experiments I test *E. culicivora*'s ability to locate by sight a potential mate in the presence of competing cues from seeing prey. Next, I investigate whether preferred olfactory cues from blood-fed female *Anopheles* and from *L. camara* enhance *E. culicivora*'s ability to find potential mates by sight in the presence of competing cues from preferred prey.

Chapter 6 is a synthetic review of my own work and the literature, especially the mate-choice literature, the literature on the psychology of attention and the literature on animal cognition. I consider my own findings from this thesis in this review.

References

- Altmann, J. (1997). Mate choice and intrasexual reproductive competition: contributions that go beyond acquiring more mates. In P. A. Gowaty (Ed.), *Feminism and evolutionary biology* (pp. 320-333). New York: Chapman & Hall.
- Anderson, J. R. (2000). *Cognitive psychology and its implications* (5th ed.). New York: Worth Publishers Inc.
- Andersson, M. (1994). *Sexual Selection*. Princeton: Princeton University Press.
- Balter, M. (2000). Can WHO roll back malaria? *Science*, 290(5491), 430.
- Blough, D. S., & Blough, P. M. (1997). Form perception and attention in pigeons. *Animal Learning and Behavior*, 25(1), 1-20.
- Blough, P. M. (1989). Attentional priming and visual search in pigeons. *Journal of Experimental Psychology: Animal Behavior Processes*, 15(4), 358-365.
- Boakes, R. (1984). *From Darwin to behaviourism: psychology and the mind of animals*. Cambridge: Cambridge University Press.
- Bonduriansky, R. (2001). The evolution of male mate choice in insects: a synthesis of ideas and evidence. *Biological Reviews*, 76(3), 305-339.
- Bonduriansky, R., & Brooks, R. J. (1998). Male antler flies (*Protophila litigata*; Diptera: Piophilidae) are more selective than females in mate choice. *Canadian Journal of Zoology*, 76(7), 1277-1285.

- Clark, R. J., Jackson, R. R., & Cutler, B. (2000). Chemical cues from ants influence predatory behavior in *Habrocestum pulex*, an ant-eating jumping spider (Araneae, Salticidae). *Journal of Arachnology*, 28(3), 309-318.
- Drickamer, L. C., Gowaty, P. A., & Wagner, D. M. (2003). Free mutual mate preferences in house mice affect reproductive success and offspring performance. *Animal Behaviour*, 65(1), 105-114.
- Driver, J., & Spence, C. (1999). Cross-modal links in spatial attention. In G. W. Humphreys & J. Duncan (Eds.), *Attention, space, and action: Studies in cognitive neuroscience* (pp. 130-149). London: Oxford University Press.
- Dukas, R. (2002). Behavioural and ecological consequences of limited attention. *Philosophical Transactions of the Royal Society of London B*, 357(1427), 1539-1547.
- Dukas, R., & Kamil, A. C. (2000). The cost of limited attention in blue jays. *Behavioral Ecology*, 11(5), 502-506.
- Dukas, R., & Visscher, P. K. (1994). Lifetime learning by foraging honeybees. *Animal Behaviour*, 48, 1007-1012.
- Enserink, M. (2000). Building a disease-fighting mosquito. *Science*, 290(5491), 440-441.
- Gowaty, P. A., Drickamer, L. C., & Schmid-Holmes, S. (2003). Male house mice produce fewer offspring with lower viability and poorer performance when mated with females they do not prefer. *Animal Behaviour*, 65(1), 95-103.
- Harland, D. P., & Jackson, R. R. (2000). 'Eight-legged cats' and how they see - a review of recent research on jumping spiders (Araneae: Salticidae). *Cimbebasia*, 16, 231-240.

- Harland, D. P., & Jackson, R. R. (2001). Prey classification by *Portia fimbriata*, a salticid spider that specializes at preying on other salticids: Species that elicit cryptic stalking. *Journal of Zoology*, 255(4), 445-460.
- Jackson, R. R., Clark, R. J., & Harland, D. P. (2002). Behavioural and cognitive influences of kairomones on an araneophagic jumping spider. *Behaviour*, 139, 749-775.
- Jackson, R. R., & Pollard, S. D. (1996). Predatory behavior of jumping spiders. *Annual Review of Entomology*, 41, 287-308.
- Jackson, R. R., & Pollard, S. D. (1997). Jumping spider mating strategies: sex among cannibals in and out of webs. In J. C. Choe & B. J. Crespi (Eds.), *The evolution of mating systems in insects and arachnids*. (pp. 340-351). Cambridge: Cambridge University Press.
- Jackson, R. R., Pollard, S. D., Nelson, X. J., Edwards, G. B., & Barrion, A. T. (2001). Jumping spiders (Araneae: Salticidae) that feed on nectar. *Journal of Zoology*, 255(1), 25-29.
- Jackson, R. R., & Wilcox, R. S. (1998). Spider-eating spiders. *American Scientist*, 86(4), 350-357.
- Kamil, A. C. (1998). On the proper definition of cognitive ethology. In R. P. Balda, I. M. Pepperberg & A. C. Kamil (Eds.), *Animal cognition in nature* (pp. 1-28). San Diego: Academic Press.
- Land, M. F., & Nilsson, D.-E. (2002). *Animal eyes*. Oxford & New York: Oxford University Press.

- Marshall, E. (2000). A renewed assault on an old and deadly foe. *Science*, 290(5491), 428-430.
- Martin-Malivel, J., & Fagot, J. (2001). Cross-modal integration and conceptual categorization in baboons. *Behavioural Brain Research*, 122(2), 209-213.
- Mazur, J. E. (1998). *Learning and behavior* (4th ed.). New Jersey: Prentice Hall.
- Meyer, D. E., & Schvaneveldt, R. W. (1971). Facilitation in recognizing pairs of words: Evidence of a dependence between retrieval operations. *Journal of Experimental Psychology*, 90(2), 227-234.
- Miller, L. H., & Greenwood, B. (2002). Malaria – a shadow over Africa. *Science*, 298(5591), 121-122.
- Morgan, C. L. (1896). *Habit and instinct*. London: E. Arnold.
- Okedi, J. (1992). Lake flies in Lake Victoria: their biomass and potential for use in animal feeds. *Insect Science and its Application*, 13(1), 137-144.
- Pain, S. (2002). Bloodlust. *New Scientist*, 176(2373), 44-47.
- Palmer, S. E. (1999). *Vision science: photons to phenomenology*. Cambridge, Massachusetts: MIT Press.
- Parsons, W. T., & Cuthbertson, E. G. (2001). *Noxious weeds of Australia* (2nd ed.). Collingwood: CSIRO Publishing.
- Pashler, H. E. (1998). *The psychology of attention*. Cambridge, Massachusetts: MIT Press.
- Pauli, P., Bourne, L. E., Jr., Diekmann, H., & Birbaumer, N. (1999). Cross-modality priming between odors and odor-congruent words. *American Journal of Psychology*, 112(2), 175-186.

- Richards, R. J. (1987). *Darwin and the emergence of evolutionary theories of mind and behavior*. Chicago: University of Chicago Press.
- Schemske, D. W. (1983). *Lantana camara*. In D. H. Janzen (Ed.), *Costa Rican natural history* (pp. 266-268). Chicago: University of Chicago Press.
- Shettleworth, S. J. (2001). Animal cognition and animal behaviour. *Animal Behaviour*, *61*, 277-286.
- Spielman, A., & D'Antonio, M. (2001). *Mosquito: a natural history of our most persistent and deadly foe*. New York: Hyperion.
- Stein, B. E., Wallace, M. T., & Stanford, T. R. (2001). Brain mechanisms for synthesizing information from different sensory modalities. In E. B. Goldstein (Ed.), *Blackwell handbook of perception. Handbook of experimental psychology series* (pp. 709-736). Malden, Massachusetts: Blackwell Publishers.
- Taubes, G. (2000). Searching for a parasite's weak spot. *Science*, *290*(5491), 434-437.
- Trivers, R. L. (1972). Parental investment and sexual selection. In B. Campbell (Ed.), *Sexual selection and the descent of man* (pp. 136-179). Chicago: Aldine.
- Vogel, G. (2002). An elegant but imperfect tool. *Science*, *298*(5591), 94-95.
- Wagner, W. E., Jr. (1998). Measuring female mating preferences. *Animal Behaviour*, *55*(4), 1029-1042.
- Watson, J. B. (1919). *Psychology from the standpoint of a behaviorist*. Philadelphia: Lippincott.
- Wesolowska, W., & Jackson, R. R. (2003). *Evarcha culicivora* sp. nov., a mosquito-eating jumping spider from East Africa (Araneae: Salticidae). *Annales Zoologici*, *53*(2), 335-338.

Wilcox, S., & Jackson, R. (2002). Jumping spider tricksters: deceit, predation, and cognition. In M. Bekoff, C. Allen & G. M. Burghardt (Eds.), *The cognitive animal: empirical and theoretical perspectives on animal cognition* (pp. 27-33).

Yoerg, S. I. (1991). Ecological frames of mind: the role of cognition in behavioral ecology. *Quarterly Review of Biology*, 66(3), 287-301.

CHAPTER 2

DISPLAY AND MATING BEHAVIOUR OF *EVARCHA CULICIVORA*, A JUMPING SPIDER (ARANEAE: SALTICIDAE) FROM EAST AFRICA

Evarcha culicivora, a jumping spider from the Lake Victoria region of Kenya and Uganda, uses an exceptionally complex and variable repertoire of behaviour patterns during interactions between conspecific individuals. Although male-male and female-female interactions are distinctive and complex, it is in male-female interactions (courtship and mating) that *E. culicivora*'s complex repertoire is most evident. As has been documented for other salticids, males use different tactics depending on the female's location and state of maturity (i.e., courtship versatility): visual displays if the female is mature and away from her nest, tactile displays if the female is mature and in her nest, cohabitation if the female is a subadult in her nest. However, male-female displays are particularly complex and variable even for a salticid and uniquely in *E. culicivora*. In male-female interactions in particular, plant species, *Ricinus communis* and *Lantana camara*, appear to have an important role. Another special feature of *E. culicivora* male-female interactions is kicking behaviour by males when mating with females, a behaviour pattern that may function as copulatory courtship. Another seemingly unique feature of *E. culicivora*'s courtship is that both the male and the female is an active participant, suggesting that this is a species for which mutual mate-choice is unusually important.

Much of the early research on salticid display (Heil, 1936; Crane, 1949; Drees, 1952) was cast in the framework of classical ethology (Tinbergen, 1963) and suggested highly stereotypical behaviour organised as releaser chains, with each individual's display eliciting in a reflex-like manner the next display in the sequence from the other individual. This portrayal of salticid interactions has been largely replaced by an appreciation of complex, highly variable sequences more suggestive of a drawn-out

negotiation rather than a stereotypical chain of reflexes (Jackson & Pollard, 1997). Much, but far from all, of salticid courtship makes use of visual cues, with elaborate movement patterns, including stepping patterns that are traditionally called ‘dances.’ Many salticids have garishly colourful markings that become especially conspicuous during courtship. The high spatial acuity of salticid eyes is unrivalled by any other animals of their size (Harland & Jackson, 2000), and the salticids’ exceptionally good eyesight makes exceptionally elaborate vision-based display possible for these spiders. However, appreciating that salticids see well does not alone explain why salticid interactions are so variable. Recent studies have combined consideration of sexual selection (Andersson, 1994) with sensory exploitation (Lunau, 1992; Proctor, 1992) and receiver psychology (Guilford & Dawkins, 1991), and suggested parallels between the intricate strategies that have evolved in araneophagic (spider eating) salticids (Jackson & Wilcox, 1998) that communicate with their prey (aggressive mimics) and the intricate negotiations that appear to transpire between potentially cannibalistic individuals during intraspecific male-female, male-male and female-female interactions (Jackson & Pollard, 1997).

Here I consider the interactions between conspecific individuals of *Evarcha culicivora*. The feeding preference of this East African salticid is unique, not only for salticids but evidently for the animal kingdom. *E. culicivora* feeds indirectly on vertebrate blood by seeking out blood-fed female mosquitoes (Pain, 2002).

There is yet another unusual feature of *E. culicivora*’s biology, an affinity for particular plant species (*Lantana* spp. and *Ricinus communis*). These plants grow wild in the Lake Victoria region of Kenya and Uganda. *E. culicivora* lives in these same habitats and feeds on nectar from the flowers of *Lantana* and the extra-floral nectaries of *R.*

communis. Preliminary research has also shown that *E. culicivora* has an especially complex display repertoire even for a salticid. In spite of this, the display repertoire of this spider has not been documented until now.

In this chapter, my objective is a first step toward understanding how individuals of this unique salticid species interact. By defining and describing the different behaviour patterns used by individuals of this salticid species during male-male, male-female and female-female interactions, with and without nests present, I establish baseline information that will be followed up in later chapters with experimental studies focussed on questions raised in this chapter.

Materials and Methods

Cultures of *Evarcha culicivora* were established from spiders collected in Kenya. Information on the rearing of the spiders (cage design, maintenance), and basic testing procedures, are detailed in Jackson and Hallas (1986). The goal in this study was to establish the spiders' basic modes of behaviour during interactions. Precise estimates of how frequently different specific patterns of behaviour occurred in different situations was not a goal. However, by following an earlier convention (Jackson and Hallas, 1986), a rough indication of frequency is provided (“usually” or “often”, “sometimes” or “occasionally”, and “infrequently” or “rarely” were used to indicate frequencies of occurrence of c. 80% or more, 20–80%, and 20% or less, respectively).

Some additional terms are important for descriptive detail. A *bout* is a period of continuous performance of a particular behaviour pattern (e.g., a bout of palp waving is a

period of continuous up-and-down motion of a palp, which may include numerous complete cycles from maximally dorsal to maximally ventral and back, with the bout ending when the palp stopped making these up-and-down cycles). *Amplitude* is the distance between the extreme positions in a movement sequence (e.g., for palp waving, the distance between the maximally dorsal and the maximally ventral position). The first major segment distal to the point of articulation was referred to in specifying the site of movement of an appendage (e.g., femoral movement: coxa-trochanter joint).

How the terms *matching phase*, *alternating phase* and *irregular phase* are used is illustrated by the following example. When two palps were waving dorso-ventrally at the same time, they were referred to as being in *matching phase* if both were at their maximally dorsal positions simultaneously. If one palp was maximally dorsal when the other was maximally ventral (phase difference 180°), they were *alternating*. *Irregular phasing* was anything between matching and alternating.

Six types of pairings of two spiders were considered: male-female, male-male, and female-female, each with and without a nest present. Encounters between spiders were staged by putting one spider in the presence of another. Encounters away from nests were defined by when one spider fixated the gaze of its principal eyes on the other spider. Encounters at nests were defined by when one spider walked onto the nest of another spider. When an encounter failed to occur within 40 min, the test was terminated. Interactions were defined by when the spiders began to adopt display behaviour (see below). An interaction ended when one spider decamped and the other spider failed to watch and follow it for the next 60 s.

There were three basic environmental conditions for staging encounters: (1) with one spider already inside a bare cage, another spider is introduced through a hole (diameter 10 mm) in the top of the cage (hole plugged with a cork before and after); (2) with one spider already inside a cage with leaves and flowers of *Lantana camara* present, another spider is introduced; (3) with one spider already on a plant (*L. camara* or *Ricinus communis*), in the open (no cage), another spider is put on the same plant at a location 15–20 mm from the first spider. For male-female encounters, either the male or the female might be the individual put in the other spider's presence.

Two broad categories of behaviour need to be addressed: (1) behaviour that was prevalent during encounters between individuals of *E. culicivora* but also prevalent in other circumstances ('general behaviour'); (2) behaviour that was seen largely if not exclusively during encounters. Besides mating behaviour, the second category includes behaviour with an apparent communication function ('displays').

GENERAL BEHAVIOUR

Normal posture

The spider's body was parallel to and only 0.5–1 mm above the substrate. Legs were loosely flexed at various joints, and the abdomen was usually aligned with the cephalothorax.

Normal palp posture

The palps hung loosely down in front of the spider's chelicerae, with femur-patella joints flexed so that the tarsi were about parallel to each other and perpendicular to the substrate.

Normal locomotion

E. culicivora tended to walk in a rapid stop-and-go fashion (e.g., step for 0.5 s, pause for 0.5 s, etc), as is typical of salticids. If severely provoked (e.g., by a researcher attempting to catch it), *E. culicivora* usually moved away rapidly, sometimes making repeated leaps combined with running. However, compared with most salticids, *E. culicivora* seemed to have an unusually calm temperament.

Predatory posture

The spider pulled all of its legs in close to its body, and also lowered its body (often it appeared to be touching the substrate). Its legs I, II and III were especially highly flexed. This posture normally preceded leaping on prey.

Palp waving

From the normal palp posture, a spider waved its two palps by moving them up and down in matching phase (amplitude 1–2 mm, 1–4/s). Bouts were often long, ranging from a few seconds to many minutes (c. 10 s was typical). Movement was femoral and tibial: femora moved forward and up, and at the same time the femora-patella joint was continuously adjusted so that the palp distal to the femur stayed oriented straight down. While waving,

the tip of the tarsus often moved from below to above the fangs, although periods of waving were also seen with tarsi tips staying below or above the fangs.

Palp stepping

The spider moved its two palps up and down in alternating phase (amplitude 0.5–3 mm, 1–5/s). Palp femora were moved up and forward, while the rest of the palp remained flexed straight, as when waving palps. As when waving palps, tarsi tips usually went from below to above the fangs in each cycle, but there were also periods when they remained above or below the fangs. When the spider was viewed head-on, a slight side-to-side wobble of the palps was often seen simultaneous with the palps moving up and down. Only adult males performed palp stepping (Fig. 2.1).

BEHAVIOURAL CATEGORIES TYPICAL OF INTERACTIONS AWAY FROM NESTS

1. Cephalothorax posture

When the spider's cephalothorax was raised, it was higher than normal above the substrate, with its anterior end sometimes tilting up 10–45°. When the spider's cephalothorax was lowered, it was more or less parallel with the substrate and positioned less than 1 mm from, if not touching, the substrate. Lowered abdomens were flexed down 45–60° from the cephalothorax such that the spinnerets nearly or actually contacted the substrate (angle between the abdomen and substrate, 45–90°). Usually, the spider's

cephalothorax was raised when its abdomen was lowered. Raised abdomens were held flexed up $10\text{--}45^\circ$ from the cephalothorax. The spider's cephalothorax was held normally (parallel to the substrate) or was lowered when its abdomen was raised.

When the spider's body was raised or lowered, its cephalothorax was held raised or lowered, with its abdomen aligned with its cephalothorax (i.e., the abdomen was neither raised nor lowered; Fig. 2.1; Fig. 2.7).

Bent abdomens were tilted $20\text{--}45^\circ$ to either side of the cephalothorax. Sometimes the abdomen was also lowered when bent. When the abdomen was bent, the spider's body was sometimes lowered but only rarely raised.

When the spider tilted its body up, its cephalothorax and abdomen were aligned (cephalothorax higher and abdomen lower) (body-to-substrate angle c. 45°). The tip of the spider's abdomen often touched the substrate.

When the spider tilted its body to the side, its legs on one side of the body were extended, raising the body on that side, and its legs on the other side of the body were flexed in so that the raised side of the body (left or right) angled up from the substrate 45° (Fig. 2.1).

2. Twitch abdomen

A spider moved its abdomen rapidly up and down from the pedicel (amplitude $0.5\text{--}1$ mm; rate $10\text{--}20/s$). Bouts of abdomen twitching were highly variable in duration, lasting from less than a second to many minutes.

3. Erect and semi-erect legs

These postures were adopted only by legs I. Joints distal to the femur-patella (and sometimes the femur-patella joints as well) were fully extended ('erect'), giving the legs a stiff appearance, or not quite fully extended ('semi-erect'). A wide variety of positioning of legs I was adopted, each variant being seen with legs either erect or semi-erect. Semi-erect was rare for each variant. Usually both legs I were held erect or semi-erect in the same position. Infrequently (1) only one leg I was erect or semi-erect, with the other leg I on substrate in the normal posture, (2) the two legs I were erect or semi-erect, but in a different erect position or (3) one leg I was erect and the other was semi-erect (same or different position).

Although positionings of erect and semi-erect legs occurred on a continuum, some modal positions were discernible (see below). However, for each position, there were additional features that varied. Except where stated otherwise, for each posture the tarsi might angle over a continuum from down by as much as 20° , sometimes with the tarsi touching the substrate, to parallel with the substrate, to up by as much as 20° .

In all erect postures, the tarsi and metatarsi of the legs I sometimes angled up by $10\text{--}20^\circ$ from the rest of the tibia ('bowed') (i.e., bowing might or might not be superimposed on the erect posture).

Position 1: legs extended straight forward, the two legs parallel with each other (femur-patella joints fully extended). Usually legs in Position 1 were parallel with the substrate.

Position 2: similar to Position 1, except for $20^\circ\text{--}45^\circ$ downward flexion of the femur-patella joints (from the patella forward, leg parallel to the substrate; Fig. 2.2).

Position 3: legs held 20° to the side, with tarsi $20\text{--}45^\circ$ up (45° flexion of the femur-patella joints (Fig. 2.3; Fig. 2.4).

Position 4: legs angled 45° to the side, with femora angled up 20° and the femur-patella joints flexed down so that the leg from the patella forward was somewhere on a continuum from parallel to the substrate to up as much as 20° (Fig. 2.1; Fig. 2.5).

Position 5: like Position 4 except that all leg joints were fully extended.

Position 6: legs held 20° out to the side, femur-patella joints straight, and tarsi angled up 20° .

Position 7: legs I held as in Position 1 except that tarsi angled 20° to the side and 20° up.

Position 8: legs held 45° to the side (femur angles up, femur-patella joint angles down 45° so that from patella to tarsus leg about parallel with the substrate).

Position 9: legs held 90° to the side (i.e., perpendicular to the sagittal plane of spider's body) (femur-patella joint straight; tarsi angle up c. 45°).

4. Palp posture

As with erect and semi-erect legs, palp posture was highly variable along a continuum but some modal postures were discerned.

Frontal: palps were held in front of the face; femur angled nearly vertically upward, with the rest of the palp angling straight down, almost pressed against the palp femur. Tips of palps were about even with the bottom of the chelicerae. The distance between the two palps in front of the spider's face was variable (almost touching to 2 mm apart; Fig. 2.2).

Retracted: like frontal palps except that palps were pulled back to side of face instead of in front of face. In the *low-retracted* posture, the palps' tarsi tips were even with the bottom of the chelicerae (Fig. 2.5). In the *high retracted* posture, palps were raised higher so that the tarsi tips were above the bottom of the chelicerae. Held in the high-retracted posture, the palps were hardly visible when the male was viewed front on (Fig. 2.6).

Forward: two palps held forward, and about parallel with each other (femur angled up c. 20° ; rest of palp, down c. 20° because of c. 20° flexion at the femur-patella joint).

Splayed: palps about perpendicular to the sagittal plane of the body (femur angled up and to the side and rest of the palp angled down and to the side by about 45°).

Forward erect and *semi-erect*: extended forward about parallel to each other and the substrate, with all joints fully or almost fully extended (i.e., like legs in erect Position 1).

Downward erect and *semi-erect*: posture extended down at 20° and to the side by 20° .

Arched in: femora extended ventro-laterally alongside the chelicerae, with the rest of the palp angling ventro-medially (palp tips converged under the chelicerae).

5. Extend palps

Whether away from or in nests, the male sometimes extended his palps (erect or semi-erect) toward the female before mounting. Typically this was when he was 2–3 mm away

from the female. Sometimes the male touched the female's face with his erect or semi-erect palps.

5. Side-to-side palp waving

From the downward-erect posture, the spider repeatedly moved its two palps inward and then outward (c. 1/s, 2–3 mm). There were two variations. In-and-out: the two palps moved in together and both out together. Left-right: the spider moved both of the palps together to the left and then both palps together to the right.

6. Opened chelicerae

Basal segments were spread apart, and fangs were usually extended. Degree of fang extension was highly variable (maximum: fangs pointed almost straight down; Fig. 2.6).

7. Leg Flicking

From erect Positions 3 or 4, one leg or both legs I moved at the same time suddenly and rapidly up and then, after a momentary pause, moved slowly down.

8. Hunched posture

Legs I–III were held more or less perpendicular to the sides of the cephalothorax. These legs were highly flexed at the femur-patella and tibia-metatarsus joints so that their tarsi pointed down and inward by as much as 45°. Tarsi I were either on or only slightly (1 mm or less) above the substrate. Tarsi II and III were on the substrate (Fig. 2.6).

The spider's cephalothorax was sometimes raised, with the abdomen lowered, and palps in the low-retracted posture.

Infrequently, the spider's body was normal or lowered, and palps were in the high-retracted posture.

9. Wags

From the hunched posture, a spider wagged by rapidly raising the hunched legs, primarily by extension of the femur-patella, then more slowly returning the legs to the hunched posture. When maximally raised during a wagging cycle, legs were usually erect or semi-erect. Usually both legs wagged, and phasing was matching. Infrequently, phasing was irregular, and infrequently only one leg wagged.

10. Arched legs

Legs I were held between 45° and 90° to the side of the body, angled up 45° at the femur, and flexed down at the femur-patella joint, so that the rest of the leg angled down 45° . Tarsi were on or close to the substrate.

11. Zigzag dance

Only males danced, and only in male-female interactions. While facing the female, the male zigzag danced by stepping to one side, pausing briefly, and then stepping to the other side, and so forth.

12. Linear dance

When linear dancing, a male stepped forward, then stepped backward either immediately or after a brief pause, and then forward again and so forth.

13. Spurt forward

A male spurted forward by stepping rapidly toward a female in a rapid stop-and-go manner. Each burst of moving forward lasted about $\frac{1}{4}$ s and each pause was of similar length.

14. Stepping to side

The spider stepped 5–10 mm in one direction, paused for c. $\frac{1}{2}$ s, and then stepped 5–10 mm in the other direction. Legs were usually held erect in Position 4. Males sometimes flicked one or both legs while stepping to the side. Sometimes, the male also changed his speed of stepping before he changed direction. Two modes of stepping to the side were discerned: smooth and jerky. When stepping to the side smoothly, onset and stopping were not abrupt. Jerky stepping to the side was sudden, and individual steps appeared to be shorter and to cause more up-and-down movement than was the case for smooth stepping to the side.

15. Sway

By flexing legs on one side and simultaneously extending legs on the other side, the spider moved its cephalothorax from side to side without stepping. The flexed legs (legs I, II and III) were hunched (i.e., when swaying, the spider alternately hunched its legs on

the left and right side). Usually, the posterior tip of the spider's abdomen stayed in place (i.e., the abdomen-cephalothorax angle changed during swaying). The swaying cycle (left, right, and back, or right, left, and back) took $\frac{1}{2}$ –1 s and the spider swayed up to four times in a row before pausing. The spider's body moved 2–4 mm.

When swaying, the spider sometimes tilted its body simultaneously 45° down to the side toward which it moved. The sagittal plane of the cephalothorax remained perpendicular to the direction of movement.

16. Embrace

Two spiders approached each other with legs hunched, moved their legs into erect Position 4 when they got close (e.g., c. 5 mm apart), continued to advance, and brought their faces, erect legs, and open chelicerae into contact. When embracing, the spiders stood face-to-face with cephalothoraces raised, and held legs I out to the side in erect Position 9, usually erect and touching, and either parallel to the substrate or down as much as 45° so that tarsi were often on the substrate. Chelicerae were usually open, with fangs extended.

17. Flee

The spider left the vicinity of another individual by running, and sometimes leaping quickly away.

18. Depart

When a spider departed, it stepped more slowly than when fleeing (i.e., it walked at more or less the normal walking speed) and rarely leapt.

19. Chase

One spider sometimes followed close behind another spider that was fleeing (usually by running, but sometimes by zigzag dancing).

20. Lunge

By suddenly and rapidly extending legs III and IV, a spider moved its body forcefully forward 1–2 mm. Tarsi of these legs did not leave the substrate.

21. Charge

A spider charged by suddenly running forward 10–40 mm, and then suddenly stopping (usually about one body length in front of the other spider).

22. Ram

When charging, instead of stopping, a spider kept going and contacted the other spider, usually head-on.

23. Strike

One spider sometimes struck another spider by bringing erect legs I (Positions 2–6) rapidly and forcefully down and forward onto the other spider. At the end of the strike, legs I were extended forward but no longer erect.

24. Truncated leaping

One spider suddenly jumped 5–10 mm toward, but did not make contact with, another spider.

25. Long leap

A spider jumped 50–70 mm towards, and sometimes made contact with, another spider. The contacted spider sometimes landed on its back, then after c. 30 s, stood back on its feet and fled.

26. Propulsive displays

A collective term, “propulsive displays,” is used for spurting forward, charging, lunging, ramming, striking, truncated leaping and long leaping (i.e., displays that entail sudden and rapid movements toward another spider).

27. Headstand

When headstanding, the spider’s cephalothorax was angled down to the front by c. 45°. Its abdomen was often flexed up 45° from the cephalothorax so that the abdomen angled up 90° to the substrate. Legs were held out to the side (flexed c. 90° at the femur-patella joints), with tarsi on the substrate. Legs I and II were close together, with legs I sometimes in the erect Position 4. One erect leg I was sometimes raised higher than the other. For example, one leg I was sometimes held erect and up 45°, while the other was erect and parallel with the substrate. Headstands were of variable duration (1–30 s).

28. Rocking

By extending and flexing its legs III and IV, but not stepping (i.e., tarsi remained on the substratum) the spider repeatedly moved its body forward and backward (amplitude 2–4 mm, 2–3/s, bout duration usually 1 s).

29. Shaking

As when rocking, the spider extended and flexed its legs without stepping, but faster and at smaller amplitude (5–10/s, <1 mm, 5–10 cycles per bout).

30. Ease forward

By stepping forward 1–3 mm, then pausing, then stepping forward 1–3 mm again, and so forth, a spider moved gradually towards another spider. While easing forward, the spider's body was lowered, and usually legs I were in erect Position 1. Typically spiders were only about five body lengths apart when easing forward was seen.

BEHAVIOUR PATTERNS REQUIRING PRESENCE OF A NEST**31. Probe**

A spider moved legs I forward and backward (1–2 mm, c. 2/s, alternating phase) so that the tarsi jerkily pushed and pulled on the silk.

32. Palpate on silk

Palps moved up and down similarly to how they moved when waving, but tarsi were usually extended more forward than during waving. The palps repeatedly contacted the silk on the downstrokes.

33. Chew on silk

With fangs in the nest silk, a spider chewed by opening and closing the basal segments of its chelicerae. Rate, amplitude and bout length varied greatly.

34. Holding nest door down

A spider inside a nest moved legs I up and contacted the silk with its tarsi. Next, by lowering its legs, a spider moved the upper layer of silk down against the lower layer. Spiders held the silk down in this fashion for a few seconds to many minutes at a time.

POST-CONTACT BEHAVIOUR**35. Premount tap with legs**

With legs in the erect Position 1 and positioned over the female, the male tapped by moving these legs up and down (movement femoral, c. 2/s, 1–2 mm, matching phase), so that tarsi I repeatedly contacted the female. The male initially tapped the female's carapace and her legs I and then, as he stepped forward and began to mount, he tapped her abdomen.

36. Quiver

A spider quivered its erect legs I (in Position 1) by moving them very rapidly (c. 10/s) and at low amplitude (0.5 mm). Bout length was usually short ($\frac{1}{2}$ –1 s).

37. Palpate on female

With his palps either forward erect (or semi-erect), a male touched a female's face much the same as when palpating on silk. Usually this was preliminary to mounting and engaging palps.

37. Mount

Males mounted by walking over females, and there were a variety of ways in which this was achieved. Sometimes, as the male zigzag danced in the female's direction, he continued advancing and moved over her without pausing or after only a momentary pause. Sometimes he first walked toward a facing female with legs erect and, after getting his erect legs I (usually in Position 1 by this stage) over her, quivered these legs over her for variable, sometimes long, periods. He moved continuously over her until mounted. Another way the male mounted the female was by stepping towards her with his legs I erect (usually in Position 1) and, when he got his legs 1 over the female, he moved in short spurts of 0.5–1 mm at a time until he gradually moved completely over the female (Fig. 2.7).

38. Postmount tap with legs

Once mounted, the male began postmount tapping by moving his legs I up and down, usually with tarsi hitting the female's abdomen. As during premount tapping, the spider's legs moved in matching phase during postmount tapping, but his legs were considerably more flexed at the femur-patella and tibia-metatarsus joints (Fig. 2.7).

39. Stroke

A male leaned to his left (or right), brought his right (or left) leg I over, and stroked by moving tarsus I repeatedly across a female's ventral abdomen (1–2/s, 1–2 mm, bout length c. 1 s).

40. Rotate abdomen

The female's abdomen rolled over c. 90° to the left or right so that its ventral surface moved closer to the male.

41. Scrape with palp

After the female's abdomen rotated, but before the male engaged his palp and started to copulate, the male scraped by moving his palps back and forth (2–4/s, c. 0.5 mm) across the ventral surface of the female's abdomen in the vicinity of her epigynum. Bout length was highly variable (up to 2 min) but usually short (c. 2 s).

42. Scrape with legs

Males scraped with legs while the female's abdomen was rotated. Legs I moved up and down (2–3 mm; c. 2/s; matching phase), with tarsi remaining in contact with the female's abdomen for all or most of the time.

43. Kicking

The male kicked by moving his two legs IV (frequently only one) up and down in matching phase. Before kicking, the male held legs IV elevated so that tarsi were in the air. There was conspicuous flexion at the femur-patella (c. 90°) and tibia-metatarsus (c. 45°) joints. If he kicked with only one leg IV, the other leg IV was left quiescent on the substrate. Often legs IV were slowly elevated higher just before kicking. A kick was achieved by suddenly and forcefully flexing the femur-patella joint and at the same time moving the whole leg in and down. On down-stroke, the male hit the female's legs IV forcefully with one or both of his legs IV, or he hit the substrate forcefully on down-stroke. Infrequently he hit the female's cephalothorax. Sometimes, legs IV made no contact with the substrate or the female. On down-stroke, there was often a superimposed quivering movement of legs IV (up and down, >10/s, <1 mm).

Infrequently the male kicked continuously for several seconds to many minutes at a time, but intermittent kicking was usual (kicked once and then paused, or kicked 2–6× in a bout then paused). The rate of kicking often started out fast, and then it slowed down. For example, sometimes a male kicked at a rate of c. 1/s at first, but soon slowed down to one kick every 2–3 s. The amplitude of kicks was usually 2–3 mm. As the male kicked, the leg IV went down fast, but then moved up more slowly. There was a momentary (1/4–

½ s) pause between the leg reaching the lower position at the end of the down-stroke and going back up again. In the interval between kicking bouts, the male sometimes held his legs IV up. This interval was typically 2–3 s at first, but then it became irregular and longer (Fig. 2.8).

44. Rubbing

After mounting, the male used his legs I to rub the female (movement femoral, <1 mm, tarsi stayed in contact with the female).

BEHAVIOUR SEQUENCES

The majority of behaviour categories that were defined above occurred across male-female, male-male, and female-female interactions. A combination of these behaviour patterns within an interaction is referred to as a *sequence*. Sequences of behaviour were complex and highly variable.

How interactions began

Patterns were hard to discern. For example, in the male-female interactions of most salticids, it is the male that usually displays first, but this role did not so strictly apply to *E. culicivora*. Either males or females might display first. Outside nests, either might display and move closer to the other and come to within a few body lengths of a facing opposite-sex individual before mutual display began. The initial display of a male or a

female, regardless of the type of interaction, varied considerably. For example, a male might initiate an interaction with a female away from nests by adopting a hunched or an erect posture, and the same applies to the female initiating a male-female interaction, and the same applies in male-male and female-female interactions.

How the hunched posture, wagging and swaying were integrated into sequences

The hunched posture was adopted by both the male and the female and it was seen in both same-sex and opposite-sex interactions. However, there were differences in how this posture was used by the two sexes. For example, when females adopted the hunched posture, their palps tended not to be especially active, and they tended to keep their palps in the normal posture. Males, however, often waved and, especially, stepped with their palps. When the male's palps were inactive, they were usually held in low retracted, splayed or downward erect posture. Females in the hunched posture tended to keep their bodies raised, but males did not. All of the female's leg tarsi usually remained on the substrate, and by keeping their legs extended females held their bodies high. Males, however, tended to remain with bodies in more or less the normal posture.

Males adopted hunched postures for highly variable lengths of time, but females adopted this posture rarely for more than 30 s. Males sometimes, but females rarely, switched between adopting the hunched posture and moving legs to a normal position and walking, then stopping, adopting the hunched posture again, or adopting an erect posture (especially Position 4).

The hunched posture was common in male-male interactions, but the two males were often seen to adopt these postures in different ways. For example, one male might

posture for a long time with one leg hunched and the other leg held erect (in Position 4), while the other male might stand with both legs in the hunched posture. When one male hunched, the other male usually backed away and wagged.

Hunching and swaying were often integrated into the same sequence. Females sometimes alternated repeatedly between hunching and swaying when interacting with males or other females, and males sometimes alternated repeatedly between hunching and swaying when interacting with females or other males. Usually the other individual in these sequences did not display in kind (i.e., the other individual did not hunch and sway at the same time).

When males hunched and swayed while interacting with females, they often stepped with their palps while hunching and held their palps stationary in the low retracted posture while swaying. After a bout of hunching and swaying, a common sequence in male-female interactions was for the male to leap towards the female. The female either stood her ground (even if she was contacted by the male), or she leapt away and fled. The male either ran after the fleeing female, or he leapt *and* ran after her.

During male-male interactions, males often stepped to the side with their legs hunched, and often they swayed immediately after doing this. Sometimes two males faced each other and swayed at the same time. Usually, when this happened, each male swayed to its own right side at the same time and then each male swayed to its own left side at the same time.

Males often combined hunching and wagging within a single sequence (during male-female or male-male interactions). Females, however, rarely combined hunching and wagging. Males sometimes wagged intermittently and seemingly unpredictably while

posturing with their legs hunched. Males that were hunching and wagging tilted their cephalothoraces up 45° and lowered their abdomens by 20° from the cephalothorax.

How propulsive displays were integrated into sequences

Propulsive displays were performed intermittently and seemingly unpredictably. One or both spiders usually turned and fled immediately after the performance of a propulsive display. Propulsive displays were routine in male-female, male-male and female-female interactions, and were combined in highly variable ways with other behaviour patterns. Females, for example, often made a single long leap or several truncated leaps in rapid succession toward another female or a male. Sometimes, these leaps ended in contact with the other spider. In male-female interactions, females sometimes made truncated leaps when males were less than 30 mm away from them, and then fled with the male usually remaining in place. Males that were in some other posture when the female made a truncated or long leap often adopted the hunched posture soon afterwards. However, sometimes a female made a series of truncated leaps, and then stopped immediately in front of the male, with the male immediately extending his legs I in the erect Position 1 over the female and quickly mounting her.

Females sometimes charged repeatedly at the male either in rapid succession or after a lag of 10 s or so between each charge. This sometimes occurred, for example as the initial display in a male-female interaction (i.e., before a male had initiated a courtship display). Usually, the male fled after being charged at, and the female usually chased after him. When the female stopped chasing the male, the male usually turned

around and displayed (erect or hunched posture). Females also rammed males, and the male was sometimes dancing when that happened.

Males sometimes approached other males or females by making truncated leaps. When a female was quiescent, for example, a male sometimes zigzag danced and then suddenly made a truncated leap towards her, after which he usually resumed his zigzag dance. A male sometimes made long leaps repeatedly toward fleeing females, and in doing so the male occasionally contacted the female once or repeatedly. After leaping at a female, the male sometimes immediately started to zigzag dance, or he might immediately adopt the hunched posture (or he might hunch and sway).

Males also chased females, usually by running, but sometimes by zigzag dancing. Charging was common in male-male interactions, but males sometimes charged or even rammed into females. Females were especially prone to fleeing during interactions with males, and this was especially common after they performed propulsive displays toward males or after the male made a propulsive display toward her. When the female fled, the male sometimes remained in place in the hunched posture, but usually he stayed in place while adopting erect Position 4. Only females performed headstanding, and they did so mostly in interactions with males. Usually the female performed a headstand for a few seconds and then immediately fled. Infrequently, females performed headstands for several minutes at a time.

How waving and stepping with palps were integrated into sequences

Although palp waving was routine for females, and both palp stepping and palp waving for males when they were stalking prey and generally whenever actively walking about or

seemingly looking at objects of interest in the environment, both of these types of palp behaviour were distinctive during interactions. Bouts of stepping with palps were nearly a universal occurrence in all interactions involving *E. culicivora* males. Often a bout of palp stepping was a male's first response in an encounter with another *E. culicivora* individual of either sex. Frequently a male switched repeatedly between palp stepping and palp waving, but with palp stepping being dominant. Switchover from waving to stepping or vice-versa sometimes happened, without a pause, one or more times in a row. Males sometimes spent long periods (lasting many minutes) with active palps alternating between waving and stepping.

How zigzag dancing, linear dancing and spurting forward were integrated into sequences

These were behaviour patterns performed only by males, and only when they were interacting with females. Sometimes these three behaviour categories occurred together in complex, variable sequences. Zigzag dancing was an especially elaborate and highly variable behaviour pattern. The distance between a male and a female when the male zigzag danced for the first time in an interaction with a female varied from 10 mm to 100 mm or more. It was common for the male to alternate between erect posturing (in Positions 1 and 5) and zigzag dancing, and sometimes the male stood inactive in an erect legs posture for 20 min or longer between switching to zigzag dancing. Zigzag dancing was sometimes a male's first display in an interaction with a female. When zigzag dancing, successive movement to the side was typically on an arc that brought the male closer to the female. The dancing male's legs were usually in erect Position 1 or 6 during

pauses between changes of direction. Often the male stepped with his palps especially fast (4/s), during the pauses. While stepping to the side, the male either kept his legs I erect and stepped with legs II–IV or he lowered legs I and used them for stepping as well. The male usually lowered his body while stepping during a zigzag dance, but sometimes he had his body raised. It was also common for the male to tilt his body to the side he was moving toward. When the male paused between steps in a dance, his body was usually raised. The male usually zigzagged back and forth 3–5 times before pausing each time, but the number of arcs might be much more (>30). Overall, the most common pattern was for the male to raise (or lower) his body and step to the side, pause and lower (or raise) his body, then step to the side again.

The speed of the zigzag dance was highly variable, between bouts and within single bouts. Sometimes, the male would slow down and speed up even while stepping in one direction on a single arc. Stepping tended to be faster when the male was closer to the female and slower when further away. There was also a trend for dances to be faster when the arcs were wide. Arcs varied most often from 20 to 50 mm, but they could be up to 80 mm. The amplitude of the arcs were wide or narrow when the male was near the female, or when distant. However, when the male danced in narrow arcs, the female sometimes stepped toward the male. She next either fled or remained inactive. When she remained inactive, the male usually next brought his legs I over her and began to mount.

Sometimes, the male also zigzag danced when chasing after a fleeing female.

Zigzag dancing was much more common than linear dancing. Linear dancing, when it occurred, was usually combined in complex sequences with zigzag dances, appearing as a brief episode interspersed within periods of zigzag dancing combined with erect and

hunched posturing. When linear dancing, with or without pausing first, a male might step forward and back several more times (amplitude usually 20 mm, but sometimes 40–50 mm).

Spurting forward was common, either combined or not combined with zigzag dancing. When spurting forward, males sometimes kept their legs in the normal posture both while stepping and during the pause between steps. More often, legs were erect in Position 3 or 4 during the pause. Usually, the male lowered his erect legs I and placed the tarsi on the ground to step forward, and moved them back to the erect posture when he stopped.

How abdomen twitching was integrated into sequences

Males and females both performed abdomen twitching in a variety of contexts, but it was especially the male's use of this behaviour that was common and conspicuous. Males interacting with females (at nests and away from nests) twitched their abdomens for especially lengthy periods. When spiders interacted away from nests, for example, the males often twitched their abdomens when in an erect or hunched legs posture, with each individual bout of abdomen twitching lasting for several seconds at a time and numerous bouts following one after the other. When spiders interacted at nests, the duration of abdomen twitching was especially variable. For example, when a male walked on the female's nest, he sometimes twitched his abdomen intermittently for a few seconds at a time or he might twitch his abdomen almost continually, with each bout being for many minutes at a time. He was also prone to twitch his abdomen as he probed the female's nest, and even after the female left the nest.

Abdomen twitching was a routine part of a male's post-contact behaviour in interactions with females, and it also accompanied copulation. For example, when mounting a female, and after he engaged a palp, the male twitched his abdomen almost continuously (amplitude of 1 mm or less). It was also especially common for males to twitch their abdomens between palp insertions, and during this time, abdomen twitching was very forceful.

Males twitched their abdomens in interactions with other males, but not so persistently. Females sometimes twitched their abdomens during interactions with males but only infrequently in interactions with other females at nests. When interacting with males, abdomen-twitching bouts of females usually lasted c. $\frac{1}{2}$ s, but sometimes the female twitched her abdomen for several seconds at a time, or even for a few minutes at a time.

Male-male interactions away from nests

Behaviour patterns of male-male interactions away from nests were highly variable, but apparently less variable than male-female interactions. Males displayed actively, but usually only briefly (1–2 min being typical) when interacting with each other, whereas male-female interactions were typically 2–5 min long and sometimes lasted for hours. When approaching each other, typically one or both of the males stepped toward the other, while at the same time hunching, swaying or wagging (or performing a combination of these).

Males often tilted up their bodies, and sometimes they flicked both legs I up while in this posture. Also while in this posture males often stepped with and waved their palps.

Palp stepping in general was very frequent in male-male interactions. However, palps were sometimes held in a retracted posture, this palp posture appearing to be more common in male-male than in male-female interactions. The retracted palps posture was especially common when the male hunched and swayed, and when he wagged. When the male adopted the hunched posture, he often waved his palps side-to-side. Males often extended their fangs (for example, when they embraced). Although the magnitude of fang extension was highly variable, full extension appeared to be more common than in male-female interactions.

Female-female interactions away from nests

When females interacted with each other, they often postured with their legs held in erect Position 4, and they also often raised their cephalothoraces. Their palps were often arched in, and often held in the normal palp posture during these interactions.

Either one or both of the two females usually adopted the prey-stalking posture when approaching the other female. When stalking brought them close to each other (e.g., to within 10 mm from each other), one or both of the females usually fled. When one female fled, the other usually did not follow. Female-female interactions were usually less than 1 min in duration.

Female-female and male-male interactions at nests

When one female or male (intruder) encountered another (resident) at a nest, the intruder usually first probed the silk and then, after pushing her or his face energetically into the

silk, chewed and tugged. The resident female or male often pulled on the silk, with their palps held downward erect.

These interactions usually began when the intruder walked on the nest and, after the resident became active inside, the intruder sometimes briefly chewed. Males occasionally palpated and probed briefly on nests of other males. When an intruder female was on the outside of a nest, the resident female sometimes pulled and held down the silk from inside. Occasionally, spiders embraced and lunged while at the door of the nest. Intruder males sometimes twitched their abdomens briefly.

Male-female interactions away from nests

These interactions were the most variable, with many different behaviour categories being combined in many varied ways. Males often began interactions by palp stepping, and soon switching to erect posturing in Position 4. Often the male alternated this posture with erect posture Position 3. When displaying in Position 4, males were especially inclined to hold only one leg I out erect, while the other leg I remained on the substrate. The male's palps were sometimes retracted and inactive while in Position 4, and sometimes the male stepped with his palps or he waved them or he did both. In the erect Position 4, the male was especially inclined to posture for many minutes at a time. Females, on the other hand, were more inclined to flick their legs I up from a hunched posture to Position 4.

Sometimes, the male alternated between zigzag dancing and hunching. For example, he sometimes hunched and swayed, then suddenly zigzag danced when he was 40 mm away from the female. Males also alternated between hunched and erect (Position

4) postures when approaching females. When this happened, the female sometimes approached, and the male wagged. Sometimes, he then mated with her. Females were especially inclined to flee or depart from a displaying male, then stop, face the male and display. Males usually followed the female, either displaying as they followed or soon after the female stopped.

Sometimes the male ended up on substrate c. 100 mm or more above the female. When this happened, to get nearer the female, the male sometimes attached a line of silk to the substrate and moved down this dragline toward the female. Once he was nearer the female, the male often started to erect posture while still on the silk line. Once on a solid substrate again, he sometimes immediately began to zigzag dance.

Sometimes, the female initiated an interaction with the male. For example, she was sometimes 90 mm away from him, and approached him in a normal posture. When she came closer to him, the male often erected his legs (but sometimes she erect postured before the male did). Females also initiated interactions by displaying first.

Sometimes there were prolonged periods during which the male stood facing a female and posturing with legs erect (most often) or hunched (less often). These periods were typically 10–60 s, but infrequently they lasted several hours if the female remained quiescent. The stationary posturing period might end when the female walked away and the male followed or it might suddenly end when the male approached, usually dancing, toward a female that was still quiescent.

Just before mounting, the male usually had his legs I in erect Position 1 and extended them over the female. The female was usually facing the male. There were, however, exceptions. For example, a male might zigzag dance toward an active female

and when close, move his legs (in erect Position 1) over her while she faced 90° away from him. Sometimes when this happened, the male mounted the female while she faced away from him.

With legs I erect (Position 1) and over a facing female, the male often tapped the female with his legs I and then began quivering his legs I over the female. Infrequently the male skipped one or the other: only quivered (i.e., did not tap) or only tapped (i.e., did not quiver). Males occasionally tapped and quivered at the same time in ½ s bouts. Sometimes, while standing with erect legs I over the female and quivering, the male had his palps in the forward posture. The female sometimes backed away repeatedly from quivering males, stopped, and then let the male move forward and quiver again. Alternatively, she turned and walked away, then turned to face the male again, allowing him to quiver. Or she might turn and display toward the male (typically in erect Position 4), then let him quiver again later.

Females sometimes made lunges or truncated leaps when the male was only a few millimetres in front of them, and sometimes even when the male quivered with his legs over the female. When the male was close, sometimes even while he had his legs over her, the female sometimes suddenly leapt backwards, and when she landed, she tended to stay in place, allowing the male to resume his display and to approach her again. Infrequently, the female leapt over the male or leapt straight up, and then fled.

Nests and cohabitation

The nests of *E. culicivora* resembled the nests of typical salticids (Richman & Jackson, 1992): a silk tube, usually with an elastic opening ('door') at each end, with length and

width only about twice to $3 \times$ the body length and width of the resident spider. Adult and subadult (i.e., a spider at the final stage of becoming an adult) females sometimes built their nests on dead leaves and other detritus suspended in spider webs (especially the webs of *Nephilengys* and *Cyrtophora*). Otherwise nests were most often seen on the sides of stones or buildings near the ground, usually hidden by grass.

Males were often found cohabiting with subadult females: each spider in a separate chamber of a dual nest (two tubes woven together, each with its doors aligned with the doors of the other). Cohabitation duration tended to be 7–10 days, as is typical of salticids (Jackson, 1986).

When a male encountered a subadult female in a nest, the two spiders interacted much the same as in male-female interactions between adult *E. culicivora*, except without mounting (see below). If the subadult female remained in her nest, the male gradually spent more and more time spinning silk on and near the subadult female's nest, usually completing an enclosing chamber within a few hours.

After the subadult female moulted and became a mature female, the male entered the female's chamber where the pair mated.

Male-female interactions at nests

As with male-female interactions away from nests, male-female interactions at nests were especially complex and highly variable. It was also difficult to differentiate these interactions from male-female away-from-nest interactions. This was because females often left and re-entered their nests during the interactions.

When a female was encountered in her nest, she sometimes turned and moved to the other door of the nest. However, she was highly inclined to come out of the nest, interact with the male outside, and then go back inside her nest again. Sometimes, when she emerged from the nest, the female immediately began headstanding. At other times, the female often had half her body outside the nest when the male approached her. When the male reached a nest, he walked onto it (often stepping with his palps at a rate of 2–4/s) and started to probe when he found the nest door. Sometimes he probed elsewhere on the nest rather than at the door. Males also routinely twitched their abdomens. When the male was at or near the door, the female usually held the door down. Sometimes she held it down also when the male was elsewhere on the nest or near but not on the nest.

Periods during which the male and female were active were sometimes followed by long periods of inactivity by both the male and female. Typically, these periods were 5–10 min long, but infrequently they lasted over an hour. Instead of complete quiescence during these periods, sometimes the male remained standing in the same place, but repositioned his legs (i.e., moved his leg tarsi a few millimetres to other place on the silk).

While probing, the male sometimes moved his legs to the erect Position 1, with his palps also being held sometimes erect or semi-erect and extended through the door. Afterward, the male walked away or he eased himself into the nest door in successive ½-s bouts.

Males usually alternated, at highly variable intervals, between being at and being away from the nest. When away from the nest, the male's behaviour varied considerably. Sometimes he remained quiescent, sometimes he remained stationary but actively waved

or stepped with his palps, and sometimes he stepped about in a localised area. The male rarely went more than 10 mm from the nest, and he generally faced the nest while away. The time away from the nest varied from a few seconds to as long as an hour.

Usually the nest had two doors and sometimes the male made repeated moves back and forth between the two nest doors. When the male moved to the other door, it was usually while the female pulled on the original door. The male walked over the nest to the opposite door and began to probe, with the female usually quickly moving from inside the nest to this door and pulling on it. Infrequently the female left the door at which the male was probing and went, from inside the nest, to the opposite door and the male then walked across the nest to the opposite door and probed. Bouts of chewing by the male were usually intermittent, and they might be at any location on the nest. Between chewing bouts, the male sometimes pressed his face against the silk and stood like that for several seconds or minutes.

As the male entered the nest door, with his body either partly or fully in the nest, he tapped and probed with his palps and advanced toward the female, extending his legs I (erect Position 1) over her when close. Sometimes, there were long periods when both the male and female stood inactive, with the male's legs (erect Position 1) in the door and over the female.

Mounting and post-mount behaviour

Just before mounting, the male and female were usually facing, and the male had his legs erect in Position 1 positioned over the female's carapace. The male mounted by walking over her. Usually, when the male began to mount, the female lowered her body and

moved her legs into the normal posture. If she was in the hunched posture, she occasionally raised her cephalothorax as the male began to mount, raised her legs I into erect posture Position 4, or both. When this happened, the male usually backed away.

When mounting the female, the male's palps were usually inactive and held in the frontal position, but the male began postmount tapping with his legs and palps immediately after he mounted the female. Then he leaned to one side and stroked. When the female rotated her abdomen, the male scraped his palp on her abdomen, then began copulating. While copulating, the male was dorsal to the female and the male and female faced in opposite directions (Posture 2 in the classification of Gerhardt & Kaestner, 1938). This is the copulatory posture adopted by most studied salticids (see Jackson, 1988). While mounting, when mounted but before engaging his palp, and while his palp was engaged, the male often twitched his abdomen.

Copulation

There were usually two initial palp engagements of more or less fixed duration per copulation. Typically the male engaged one palp (left or right) than switched to the other palp about 2 min later. After another 2 min, the male disengaged and switched palps again. Duration and sequence of palp engagements became more variable after the second. If the female remained more or less quiescent, the male usually continued to alternate palps, but with successive palp-engagement durations getting longer. If the female became active, males sometimes disengaged and then engaged the same palp again.

During the interval between palp engagements, the male usually moved to the centre of the female, and then he tapped her again. The female's abdomen usually rotated back to normal, and she sometimes raised her legs I. When the female became active between palp engagements, the male usually continued to tap, but infrequently he backed off the female displayed and then mounted again.

Kicking

Kicking was performed only by males, only during interactions with females and only while mounting and copulating. Males often kicked after they had mounted but before they engaged a palp. Kicking while mounting was rare. Males always kicked during periods when palps were engaged. Males also kicked sometimes while mounted between successive palp engagements. If the female became active while he was mounted (whether he had engaged a palp or not), the male often started to kick if he had not yet done so, or he kicked faster and more forcefully if he had already started to kick. For example, the female sometimes dragged the male along (while still mounted) for many millimetres, and his palp either did or did not stay engaged while this happened. During this time, the male usually kicked forcefully. When the female became quiescent again, copulation usually resumed.

Sometimes males adopted a routine of briefly twitching their abdomens and kicking at the same time: the male's abdomen moved down simultaneous with his legs going down; after the kicking legs IV reached the maximally down position, the male's abdomen twitching continued for c. 1 s longer. At other times, kicking and abdomen twitching were performed simultaneously more or less continuously in lengthy bouts.

Characteristically, kicking and abdomen twitching were both performed especially forcefully whenever they were performed at the same time.

Interactions on *Lantana camara* and *Ricinus communis*

When on *L. camara* and *R. communis*, male-male, female-female and male-female interactions were in basic respects similar to these same types of interactions when the spiders were in bare cages. The same behaviour categories were seen in similar sequences. However, variability appeared to be much greater when on plants. The spiders readily went on to these plants. Once on *L. camara* plants in particular, they appeared reluctant to leave. They tended to spend their time especially on the flowers of *L. camara*.

The two spiders moved actively through the dense flower clusters. Routinely, the spider's path to and view of the other spider would be occluded by vegetation and flowers. Yet, on this complex 3-D space, males zigzag danced, females charged and performed headstands, and so forth.

DISCUSSION

Many salticid males practise courtship versatility (i.e., they perform different behaviour patterns in their courtship display depending on the female's location and maturity; Jackson, 1992; Jackson & Pollard, 1997). Type 1 courtship, which relies primarily on vision-based communication, is used when the female is outside her nest. Especially elaborate vision-based courtship sets salticids apart from other spiders (Jackson, 1982;

Foelix, 1996). No other spiders have the salticid's ability for acute eyesight, and it is the salticid's high visual acuity (Harland & Jackson, 2000) that underlies the salticid's capacity for such pronounced reliance on vision-based communication. Yet the salticid is not restricted to vision-based communication. When a female is encountered inside her nest, vision-based communication may not be especially effective, and sometimes it is not feasible at all. Salticid nests are usually densely woven and often they are built in dark places such as in rolled-up leaves and under stones where ambient light levels are very low (Jackson, 1992). Under these circumstances, males perform Type 2 courtship, which does not depend on vision but instead relies on sending vibratory or tension signals through the silk to the female (Jackson, 1992).

The salticid male's courtship is also adjusted to the female's state of maturity. When a subadult female is encountered inside her nest, the male typically begins by performing Type 2 courtship. Following this, the male builds a chamber on the subadult female's nest and cohabits there until she moults and matures (Jackson, 1992). Before copulation begins, there is a phase of salticid courtship, 'postmount courtship,' that is common to both Type 1 and Type 2 and relies on tactile signals.

By practising courtship versatility, *Evarcha culicivora* resembles numerous other salticids that have been studied. Many of the particular behaviour categories adopted by *E. culicivora* also have close parallels in other salticid species. Erect legs, hunched legs, wagging, propulsive displays, embracing, linear dancing and zigzag dancing are, for example, displays during Type 1 courtship that *E. culicivora* shares with other salticids. Probing, holding silk down, and chewing are all examples of behaviour shared by *E. culicivora* and other salticid species during Type 2 courtship. Tapping, scraping and

stroking are examples of behaviour during postmount courtship shared by *E. culicivora* with other salticid species.

However, interactions of *E. culicivora* were distinctive. All salticids have exceptionally complex display repertoires (Jackson & Pollard, 1997), but *E. culicivora*'s display repertoire is extreme even for a salticid. The display repertoire of *E. culicivora* includes exceptionally many behaviour categories, and these are combined in the most complex and variable sequences ever reported for a spider.

Extravagant signalling by males as a preliminary to mating (i.e., extravagant courtship) is traditionally examined in the context of intersexual selection. Important questions remain regarding the relative importance of runaway selection (Fisher, 1930), truth-in advertising (Dawkins & Krebs, 1978), the handicap principle (Zahavi, 1975, 1977) and sensory exploitation (Endler, 1992; Endler & Basolo, 1998) as explanations for display elaboration. The peacock's (*Pavo cristatus*) tail is often envisaged as a classic example of an extravagant male secondary sexual characteristic in the literature on the evolution of mate-choice behaviour (e.g., Andersson, 1994). The large display repertoires and complex display sequences of salticids might be envisaged as a spider parallel to the peacock's tail. As with how peahen preference for elaborate plumage may have driven the evolution of the peacock's tail, the female salticid preference for elaborate display sequences might have driven the evolution of male salticid behaviour.

However, for the peahen and for the female salticid, the challenge is to explain how individuals that execute choice for elaborate signals tend to benefit by their choices. Hamilton and Zuk (1982), considering especially bird plumage, developed a particular variation on the handicap principle and truth-in-advertising hypothesis. Their hypothesis

has been especially influential. They linked a hypothesis about benefits to females choosing elaborate male traits to the theory of host-parasite coevolution, and something that is sometimes called the 'Red Queen Hypothesis.' The basic idea is that host species evolution is driven by parasites and parasite evolution is driven by the host in something like an arms race. Hosts are continually selected for better defence against parasites and parasites are continually selected for better ability to overcome host defences. Hamilton and Zuk's (1982) hypothesis was that female genotypes for selecting as mates particular males that signal reliably their success at defeating parasites spread over evolutionary time because genotypes are more successful at combining with male genotypes for defeating parasites. In short, the male is more successful at getting chosen by females when he can reliably demonstrate his parasite-resistance ability.

Other fitness-related characteristics besides parasite resistance may also be relevant, and even if selection of parasite resistance or other fitness-related traits drives mate-choice behaviour, runaway selection might also be important because, once a preference for a male trait is established in a population, it will benefit females all else being equal, and assuming the traits in question are heritable, to choose the preferred type of male simply because her sons will tend to also be the preferred type of male.

That *E. culicivora* males might reliably advertise resistance to parasites or some other fitness-related heritable attributes is unknown, but could probably be investigated experimentally. However, the manner in which elaborate display and fitness are linked for *E. culicivora* might differ in an interesting way for how this is envisaged working for peacocks, for instance. The hypothesis Hamilton and Zuk (1982) proposed works only if cheating is difficult, if not impossible. For example, the idea is that a male bird carrying a

large parasite load simply is not healthy enough to produce the plumage females prefer. Something similar has been proposed before for another salticid, *Phidippus johnsoni* (Jackson, 1981), where females are more likely to mate with a male if he dances. It was suggested, but not shown, that only especially healthy males have the motor skills required for dancing.

However, *E. culicivora*'s behaviour suggests a different, more cognitive, hypothesis. Complex sequences and extreme variability suggest this hypothesis. Rather than demonstrating health or fitness with plumage or motor skill, the *E. culicivora* male may be honestly advertising fitness by showing his cognitive abilities required for generating complex, variable displays.

However, there are additional complicating factors when considering the courtship of *E. culicivora*. One of these factors is that in *E. culicivora*, males and females both appear to be active in display and both the male and the female appear to exercise mate-choice behaviour (seeming to prefer larger mates). Pronounced mutual mate-choice is suggested by this study of *E. culicivora*, which has not been documented before in spiders. I will examine this in more depth in Chapter 3. If the evolution of elaborate display in *E. culicivora* has been driven by mate choice for cognitive-related reliable advertisement of fitness, then these observations suggest this has been a two-way process (males both selecting and advertising, and females both selecting and advertising). Another complication is that, although this study suggests that male-female interactions may be more complex than male-male and female-female interactions, there is, nonetheless, a high level of complexity in the intrasexual interactions. Sexual selection theory may be relevant for explaining an extra level of complexity in male-female

interactions, but the complexity of male-male and female-female interactions suggest that something more applies to male-female interactions as well.

E. culicivora's post-mount behaviour suggests that this is a spider species in which copulatory courtship is pronounced. The tradition has been until recently to envisage courtship as exclusively a preliminary to copulation. Courtship has been envisaged as communication that facilitates copulation, with communication no longer being relevant once copulation begins. Success at achieving copulation, however, may often not correspond simply with success at reproducing. Females may exercise cryptic choice, this being a prerequisite for the evolution of copulatory courtship (Eberhard, 1991). A female may, for example, make decisions about whether or not to use a male's sperm on the basis of signalling during copulation. For example, with insects, *Drosophila birchii* and *Drosophila serrata* females discriminate against the sperm of males that do not sing during mounting and copulation (Hoikkala et al., 2000). The male *E. culicivora*'s kicking behaviour may be comparable to the *Drosophila* male's song. This hypothesis can probably be tested experimentally.

REFERENCES

- Andersson, M. (1994). *Sexual Selection*. Princeton: Princeton University Press.
- Crane, J. (1949). Comparative biology of salticid spiders at Rancho Grande, Venezuela. Part IV. An analysis of display. *Zoologica: contributions of the New York Zoological Society*, 34, 159-215.
- Dawkins, R., & Krebs, J. R. (1978). Animal signals: information or manipulation. In J. R. Krebs & N. B. Davies (Eds.), *Behavioural ecology: an evolutionary approach* (pp. 282-309). Oxford: Blackwell Scientific Publications.
- Drees, O. (1952). Untersuchungen über die angeborenen Verhaltensweisen bei Springspinnen (Salticidae). *Zeitschrift für Tierpsychologie*, 9, 169-207.
- Eberhard, W. G. (1991). Copulatory courtship and cryptic female choice in insects. *Biological Reviews*, 66(1), 1-31.
- Endler, J. A. (1992). Signals, signal conditions, and the direction of evolution. *The American Naturalist*, 139 (Suppl.), S125-S153.
- Endler, J. A., & Basolo, A. L. (1998). Sensory ecology, receiver biases and sexual selection. *Trends in Ecology & Evolution*, 13(10), 415-420.
- Fisher, R. A. (1930). *The genetical theory of natural selection*. Oxford: Clarendon Press.
- Foelix, R. F. (1996). *Biology of spiders* (2nd ed.). Oxford: Oxford University Press.
- Gerhardt, U., & Kaestner, A. (1938). Araneae. In W. G. Kukenthal & T. Krumbach (Eds.), *Handbuch der Zoologie* (Vol. 3, pp. 394-656). Berlin: De Gruyter.
- Guilford, T., & Dawkins, M. S. (1991). Receiver psychology and the evolution of animal signals. *Animal Behaviour*, 42, 1-14.

- Hamilton, W. D., & Zuk, M. (1982). Heritable true fitness and bright birds: a role for parasites? *Science*, *218*, 384-387.
- Harland, D. P., & Jackson, R. R. (2000). 'Eight-legged cats' and how they see - a review of recent research on jumping spiders (Araneae: Salticidae). *Cimbebasia*, *16*, 231-240.
- Heil, K. H. (1936). Contributions to the physiology and psychology of the jumping spiders/Beitraege zur Physiologie und Psychologie der Springspinnen. *Zeitschrift fuer Vergleichende Physiologie*, *23*, 1-25.
- Hoikkala, A., Crossley, S., & Castillo-Melendez, C. (2000). Copulatory courtship in *Drosophila birchii* and *D. serrata*, species recognition and sexual selection. *Journal of Insect Behavior*, *13*(3), 361-373.
- Jackson, R. R. (1981). Relationship between reproductive security and intersexual selection in a jumping spider *Phidippus johnsoni* (Araneae: Salticidae). *Evolution*, *35*(3), 601-604.
- Jackson, R. R. (1982). The behavior of communication in jumping spiders (Salticidae). In P. N. Witt & R. J. S (Eds.), *Spider communication. Mechanisms and ecological significance* (pp. 213-247). Princeton: Princeton University Press.
- Jackson, R. R. (1986). Cohabitation of males and juvenile females: a prevalent mating tactic of spiders. *Journal of Natural History*, *20*(5), 1193-1210.
- Jackson, R. R. (1988). The biology of *Tauala lepidus*, a jumping spider (Araneae: Salticidae) from Queensland: display and predatory behaviour. *New Zealand Journal of Zoology*, *15*, 347-364.

- Jackson, R. R. (1992). Conditional strategies and interpopulation variation in the behaviour of jumping spiders. *New Zealand Journal of Zoology*, 19(3-4), 99-111.
- Jackson, R. R., & Hallas, S. E. A. (1986). Comparative biology of *Portia africana*, *P. albimana*, *P. fimbriata*, *P. labiata* and *P. shultzi[schultzi]*, araneophagic, web-building jumping spiders (Araneae: Salticidae): utilisation of webs, predatory versatility, and intraspecific interactions. *New Zealand Journal of Zoology*, 13(4), 423-489.
- Jackson, R. R., & Pollard, S. D. (1997). Jumping spider mating strategies: sex among cannibals in and out of webs. In J. C. Choe & B. J. Crespi (Eds.), *The evolution of mating systems in insects and arachnids*. (pp. 340-351). Cambridge: Cambridge University Press.
- Jackson, R. R., & Wilcox, R. S. (1998). Spider-eating spiders. *American Scientist*, 86(4), 350-357.
- Lunau, K. (1992). Evolutionary aspects of perfume collection in male euglossine bees (Hymenoptera) and of nest deception in bee-pollinated flowers. *Chemoecology*, 3(2), 65-73.
- Pain, S. (2002). Bloodlust. *New Scientist*, 176(2373), 44-47.
- Proctor, H. C. (1992). Sensory exploitation and the evolution of male mating behaviour: A cladistic test using water mites (Acari: Parasitengona). *Animal Behaviour*, 44(4), 745-752.
- Richman, D. B., & Jackson, R. R. (1992). A review of the ethology of jumping spiders (Araneae, Salticidae). *Bulletin of the British Arachnological Society*, 9(2), 33-37.

Tinbergen, N. (1963). On aims and methods of ethology. *Zeitschrift fur Tierpsychologie*, 20, 410-433.

Zahavi, A. (1975). Mate selection, a selection for a handicap. *Journal of theoretical biology*, 53, 205-214.

Zahavi, A. (1977). Reliability in communication systems and the evolution of altruism. In B. Stonehouse & C. M. Perrins (Eds.), *Evolutionary ecology* (pp. 253-259). London: Macmillan.



Figure 2.1. *E. culicivora* male displaying in erect Position 4. Stepping with palps. Body raised and slightly tilted to the side. On *L. camara* plant.



Figure 2.2. *E. culicivora* male displaying in erect Position 2 (female out of focus in photograph). Male's palps in frontal posture.

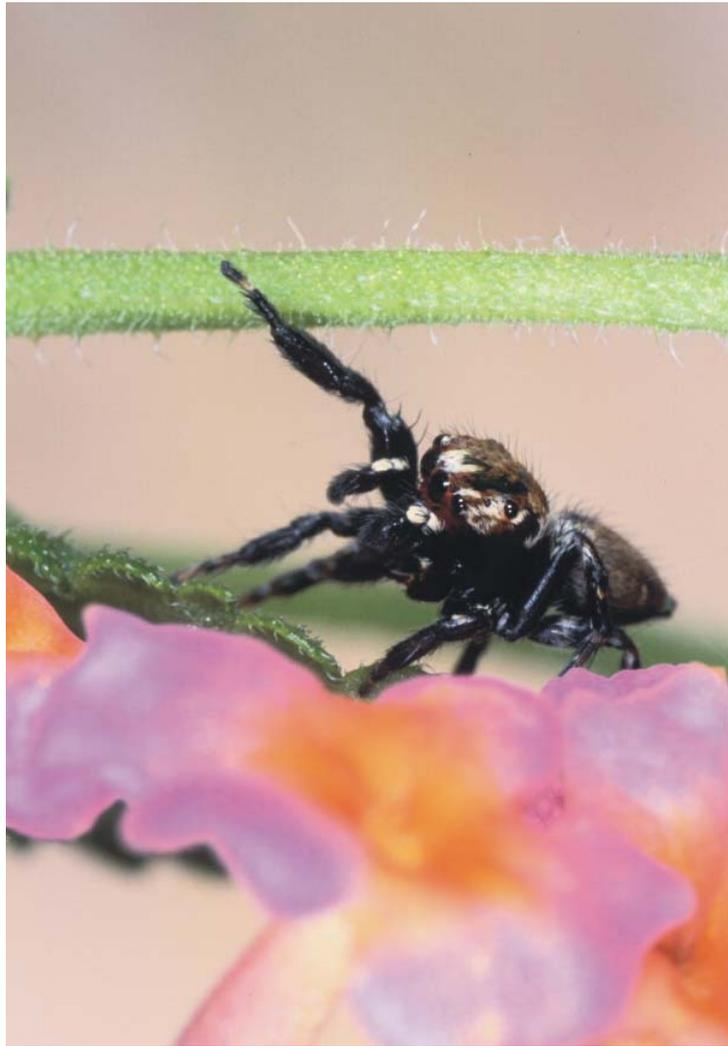

Figure 2.3. *E. culicivora* male displaying erect Position 3. On *L. camara* plant.



Figure 2.4. *E. culicivora* male displaying in erect Position 3. On *L. camara* plant.



Figure 2.5. *E. culicivora* male displaying in erect Position 4. Erect leg I bowed. Palps held in low retracted posture. On *L. camara* flower.



Figure 2.6. *E. culicivora* male displaying in high-retracted palps posture. Legs I hunched. Fangs spread apart.



Figure 2.7. *E. culicivora* male mounting and performing postmount tapping on the female. Male's body raised. Female's body lowered.



Figure 2.8. *E. culicivora* male copulating with female. Male kicking (legs IV raised). On *L. camara* leaf.

CHAPTER 3

THE INFLUENCE OF BODY SIZE IN THE MATE-CHOICE DECISIONS OF *EVARCHA CULICIVORA*, A MOSQUITO-EATING JUMPING SPIDER (ARANEAE: SALTICIDAE) FROM EAST AFRICA

Adult males and adult females of *Evarcha culicivora* vary from 3 mm to 9 mm in body length. Experimental evidence supports three hypotheses: (1) *E. culicivora* is a species in which mutual mate-choice is pronounced (i.e., the male and the female both exercise pronounced mate-choice behaviour); (2) each sex prefers larger opposite-sex individuals as potential mates; (3) mate-choice decisions can be made on the basis of optical cues alone. The potential links between *E. culicivora*'s unusual feeding habits and the success of adults of this species at attracting mates are discussed.

Body size may often influence the outcome of the male-male contests of jumping spiders (Salticidae), with larger individuals having an advantage (Wells, 1988; Jackson & Cooper, 1991; Faber & Baylis, 1993; Taylor et al., 2001), but there have been no experimental studies of whether body size influences salticid mate-choice behaviour. Here, I investigate the mate-choice behaviour of *Evarcha culicivora*, a salticid from East Africa. This salticid is of unusual interest because its preferred prey are blood-fed female mosquitoes (Pain, 2002). Findings from Chapter 2 suggested another way in which *E. culicivora* appears to be an unusual salticid: mate-choice behaviour may be pronounced in both sexes of *E. culicivora*. The earlier work (Chapter 2) also suggested that both the males and the females of this species prefer larger individuals of the opposite sex as mates. Furthermore, because salticids have exceptionally good eyesight (Harland & Jackson, 2000, 2001;

Land & Nilsson, 2002), the mate-choice decisions of *E. culicivora* might rely strongly on optical cues.

The prevalent pattern in salticids (Jackson & Pollard, 1997) appears to match what Trivers (1972) described as conventional sex roles in the animal kingdom: because females tend to be a limiting resource for males, it is common for males to attempt to mate especially often, to engage readily in male-male contests for access to females and generally to take a more active role in courtship; females, instead of taking an especially active role in courtship, tend to concentrate on discriminating between different males and making precise mate-choice decisions. Trivers' (1972) argument for why the level of choosiness exhibited by males and females follows this pattern was based on inherent intersexual differences of parental investment which can usually be traced back to differences in gamete size. Trivers' (1972) theory immediately generated considerable interest in a sizeable minority of animals where 'sex-role reversal' has evolved. These species, where females are more active in courtship and males exercise more pronounced mate-choice behaviour (e.g., Verrell, 1994; Bonduriansky, 2001), appear to be tests of Trivers' (1972) theory and numerous studies have clarified factors other than gamete size that may reverse the typical male-female disparity in parental investment. However, what Trivers (1972) articulated was an argument about differences in degree of choosiness, not an argument implying qualitative differences in sex roles. Much of the subsequent literature may have lost sight of this. However, the recent literature has shown a growing interest in mutual mate-choice (Altmann, 1997; Kokko & Johnstone, 2002; Gowaty et al., 2003; Drickamer et al., 2003). Pronounced mutual mate-choice, however, has not been documented before in spiders.

My hypotheses for this chapter are that *E. culicivora* females prefer larger males and *E. culicivora* males prefer larger females, and that *E. culicivora* discerns the body size of opposite-sex individuals by use of vision alone and in the absence of movement-pattern cues.

Materials and Methods

Interpreting findings from interactions between living spiders as mate choice is problematical. When two spiders interact with one another, the outcome usually cannot be attributed in any straightforward way to the decisions of one rather than the other interacting individual. Here, I avoided these complications by having only one living individual in each mate-choice test. Test spiders were given an opportunity to choose between four vials (Fig. 3.1), one vial positioned on each side of a square box. On each side of each vial there was a mount (i.e., a dead opposite-sex individual of *E. culicivora* glued in lifelike posture to a cork). Each mount faced directly toward the side of the box. Defined by body length, there were two types of mounts (giants, 9 mm; midgets, 3 mm) in each test (same size type on opposite sides of the box, different size type on adjacent sides of the box).

Testing began by introducing a test spider (an adult male or an adult female of *E. culicivora*) through the hole in the centre of the top of the box. Once inside, the test spider was free to move around and enter any of the four vials. Tests lasted 60 min or until the test spider made a choice. When the spider entered, and then stayed inside, any one of the four vials for 30 s, this was recorded as its choice. The rationale for the 30-s criterion was that, in preliminary trials, although *E. culicivora* often entered a vial for a

few seconds and then left, any *E. culicivora* that stayed in a vial for 30 s remained in this vial for at least 5 min longer.

None of the test spiders had mated and all were 6 mm in body length (6 mm was about mid-way in the range of body lengths known for this species). All test spiders were maintained before testing on a mixed diet (i.e., lake flies and blood-fed *Anopheles* females). Altogether, 72 males and 67 females were tested and were tested only once. All data were analysed using chi-square tests for goodness of fit (see Howell, 2002).

Results

E. culicivora males chose giant females significantly more often than they chose midget females ($\chi^2 = 7.896$, $p < 0.01$; Fig. 3.2) and *E. culicivora* females chose giant males significantly more often than they chose midget males ($\chi^2 = 6.897$, $p < 0.01$; Fig. 3.3).

Discussion

In another salticid, *Maevia inclemens*, females make vision-based mate-choice decisions where the male's initial movement determines female response (Clark & Uetz, 1992, 1993). However, movement pattern was not a variable in the experiments with *E. culicivora* because I used motionless mounts. What I show instead is that, independent of movement-pattern cues, males and females of *E. culicivora* make vision-based discriminations between two sizes of opposite-sex conspecifics and consistently choose the larger of the two. This is the first experimental demonstration of size-related mate-choice by a salticid. Vision-based size discrimination might be expected from an appreciation of the unique, complex eyes of salticids (Harland & Jackson, 2001). Most

spiders have simple eyes and poor eyesight (Land, 1985), but salticids have visual acuity exceeding that of any other animals of comparable size (Harland & Jackson, 2000; Land & Nilsson, 2002).

Vision-based size discrimination by a salticid has been shown experimentally before by using motionless mounts, but in the context of predation instead of in the context of mate-choice. *Portia fimbriata*, an araneophagic salticid, chooses larger prey spiders more often than smaller prey spiders (Li & Jackson, 1996). Using mounts, the criteria for prey-choice (Li & Jackson, 1996) and mate-choice (this study) were short of actual predation or mating, as is common in choice experiments on animals in general, not just salticids (Clark & Uetz, 1992, 1993; Swaddle & Cuthill, 1994; Wiernasz, 1995). It would be difficult to design an experiment in which actual predation or mating might occur without introducing the other variables involved when using live spiders. The advantage of using mounts is that test outcomes can be readily interpreted as showing the decisions of the test spider and readily interpreted as response specifically to optical cues and as independent of movement cues.

Further investigation is needed for clarifying the adaptive advantage males and females of *E. culicivora* might gain by choosing as mates individuals of larger body size, but mate-choice preference for larger individuals of the opposite sex may be common in a wide range of animals, including garter snakes (*Thamnophis sirtalis parietalis*; Shine & Mason, 2001), cichlid fish (*Cichlasoma nigrofasciatum*; Noonan, 1983) and antler flies (*Protophihila litigata*; Bonduriansky & Brooks, 1998).

The experimental results in this chapter support the tentative conclusion from Chapter 2. Evidently, *E. culicivora* is a salticid species in which mutual mate choice is

pronounced. This finding leaves numerous questions unanswered, including whether pronounced mutual mate-choice, an apparently exceptional feature of *E. culicivora*'s mating strategy, is related in some way to this species' unusual prey preference, its affiliation with plants or both.

One question that could be addressed in further research is whether *E. culicivora*'s success at hunting blood-fed mosquitoes is linked with its success at attracting mates. *E. culicivora*'s dietary preferences are unusual, and difficult to satisfy. Earlier work (Jackson, unpublished data) has shown that juveniles of *E. culicivora* attain larger adult size after feeding on mosquito-derived blood and attain smaller adult size when blood is absent from their diet. Body-size variation in the population of *E. culicivora* suggests that some *E. culicivora* individuals are more successful than others at hunting blood-fed female mosquitoes. Large body size appears to be a reliable indicator that an individual has been especially successful as a hunter when a juvenile. Females that choose larger *E. culicivora* males rather than smaller *E. culicivora* males, and males that choose larger *E. culicivora* females instead of smaller *E. culicivora* females, may tend to produce more successful offspring. A step toward testing this hypothesis would be to determine the heritability of hunting proficiency.

References

- Altmann, J. (1997). Mate choice and intrasexual reproductive competition: contributions that go beyond acquiring more mates. In P. A. Gowaty (Ed.), *Feminism and evolutionary biology* (pp. 320-333). New York: Chapman & Hall.
- Bonduriansky, R. (2001). The evolution of male mate choice in insects: a synthesis of ideas and evidence. *Biological Reviews*, *76*(3), 305-339.
- Bonduriansky, R., & Brooks, R. J. (1998). Male antler flies (*Protophihila litigata*; Diptera: Piophilidae) are more selective than females in mate choice. *Canadian Journal of Zoology*, *76*(7), 1277-1285.
- Clark, D. L., & Uetz, G. W. (1992). Morph-independent mate selection in a dimorphic jumping spider: demonstration of movement bias in female choice using video-controlled courtship behaviour. *Animal Behaviour*, *43*(2), 247-254.
- Clark, D. L., & Uetz, G. W. (1993). Signal efficacy and the evolution of male dimorphism in the jumping spider, *Maevia inclemens*. *Proceedings of the National Academy of Sciences of the United States of America*, *90*(24), 11954-11957.
- Drickamer, L. C., Gowaty, P. A., & Wagner, D. M. (2003). Free mutual mate preferences in house mice affect reproductive success and offspring performance. *Animal Behaviour*, *65*(1), 105-114.
- Faber, D. B., & Baylis, J. R. (1993). Effects of body size on agonistic encounters between male jumping spiders (Araneae: Salticidae). *Animal Behaviour*, *45*(2), 289-299.

- Gowaty, P. A., Drickamer, L. C., & Schmid-Holmes, S. (2003). Male house mice produce fewer offspring with lower viability and poorer performance when mated with females they do not prefer. *Animal Behaviour*, *65*(1), 95-103.
- Harland, D. P., & Jackson, R. R. (2000). 'Eight-legged cats' and how they see - a review of recent research on jumping spiders (Araneae: Salticidae). *Cimbebasia*, *16*, 231-240.
- Harland, D. P., & Jackson, R. R. (2001). Prey classification by *Portia fimbriata*, a salticid spider that specializes at preying on other salticids: Species that elicit cryptic stalking. *Journal of Zoology*, *255*(4), 445-460.
- Howell, D. C. (2002). *Statistical methods for psychology* (5th ed.). Belmont, California: Wadsworth.
- Jackson, R. R., & Cooper, K. J. (1991). The influence of body size and prior residency on the outcome of male-male interactions of *Marpissa marina*, a New Zealand jumping spider (Araneae Salticidae). *Ethology, Ecology & Evolution*, *3*(1), 79-82.
- Jackson, R. R., & Pollard, S. D. (1997). Jumping spider mating strategies: sex among cannibals in and out of webs. In J. C. Choe & B. J. Crespi (Eds.), *The evolution of mating systems in insects and arachnids*. (pp. 340-351). Cambridge: Cambridge University Press.
- Kokko, H., & Johnstone, R. A. (2002). Why is mutual mate choice not the norm? Operational sex ratios, sex roles and the evolution of sexually dimorphic and monomorphic signalling. *Philosophical Transactions of the Royal Society of London B*, *357*(1419), 319-330.

- Land, M. F. (1985). The morphology and optics of spider eyes. In F. G. Barth (Ed.), *Neurobiology of arachnids* (pp. 53-78). Berlin: Springer-Verlag.
- Land, M. F., & Nilsson, D.-E. (2002). *Animal eyes*. Oxford & New York: Oxford University Press.
- Li, D., & Jackson, R. R. (1996). Prey preferences of *Portia fimbriata*, an araneophagic, web-building jumping spider (Araneae: Salticidae) from Queensland. *Journal of Insect Behavior*, *9*(4), 613-642.
- Noonan, K. C. (1983). Female mate choice in the cichlid fish *Cichlasoma nigrofasciatum*. *Animal Behaviour*, *31*(4), 1005-1010.
- Pain, S. (2002). Bloodlust. *New Scientist*, *176*(2373), 44-47.
- Shine, R., & Mason, R. T. (2001). Courting male garter snakes (*Thamnophis sirtalis parietalis*) use multiple cues to identify potential mates. *Behavioral Ecology and Sociobiology*, *49*(6), 465-473.
- Swaddle, J. P., & Cuthill, I. C. (1994). Preference for symmetric males by female zebra finches. *Nature*, *367*(6459), 165-166.
- Taylor, P. W., Hasson, O., & Clark, D. L. (2001). Initiation and resolution of jumping spider contests: roles for size, proximity, and early detection of rivals. *Behavioral Ecology and Sociobiology*, *50*(5), 403-413.
- Trivers, R. L. (1972). Parental investment and sexual selection. In B. Campbell (Ed.), *Sexual selection and the descent of man* (pp. 136-179). Chicago: Aldine.
- Verrell, P. A. (1994). Males may choose larger females as mates in the salamander *Desmognathus fuscus*. *Animal Behaviour*, *47*(6), 1465-1467.

Wells, M. S. (1988). Effects of body size and resource value on fighting behaviour in a jumping spider. *Animal Behaviour*, 36(2), 321-326.

Wiernasz, D. C. (1995). Male choice on the basis of female melanin pattern in *Pieris* butterflies. *Animal Behaviour*, 49(1), 45-51.

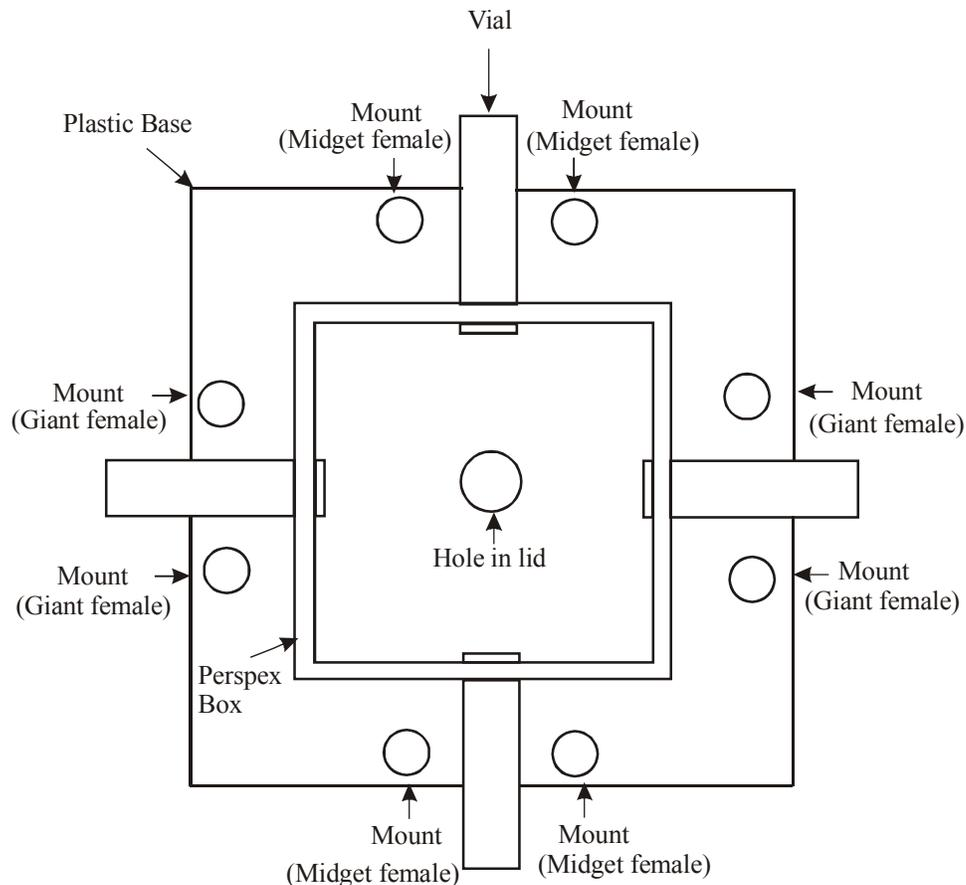

Figure 3.1. Mate-choice apparatus (not drawn to scale) made of clear Perspex. Square box (100 mm × 100 mm, walls 35 mm high and 5 mm thick), with removable lid. Lid (100 mm × 100 mm) held in place by 5-mm wide rim (5 mm from edge of box). Hole (diameter 16 mm) centred on each of four sides of the box (i.e. centre of hole 6 mm from top and 6 mm from bottom of box; equidistant from left and right sides of wall). Transparent glass vial (15 mm in diameter, 50 mm long) positioned in each of these four holes. Test spider enters vials from inside box. Test initiation: test spider enters through cork-plugged hole (diameter 16 mm) in lid and gains access to four vials (vials open on inside of box, but closed on outside of box). One mount on each side of each vial (either two giant or two midget females, as in this drawing, when test spider was male; either two giant or two midget males when test spider was female). Box sat on a 160 mm

× 160 mm plastic base, and each mount was placed on this base (secured with double-sided tape on the bottom of each cork). Each mount situated 10 mm to side of vial, and 15 mm from side of box.

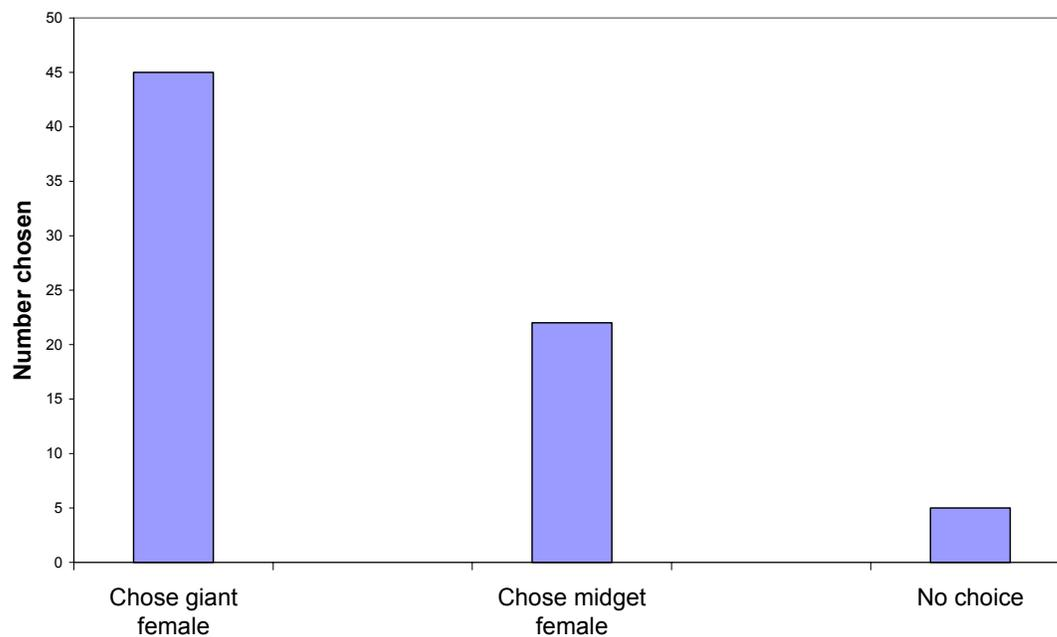

Figure 3.2. Results of mate-choice tests for *Evarcha culicivora* males. Chose giant significantly more often than midget conspecific females.

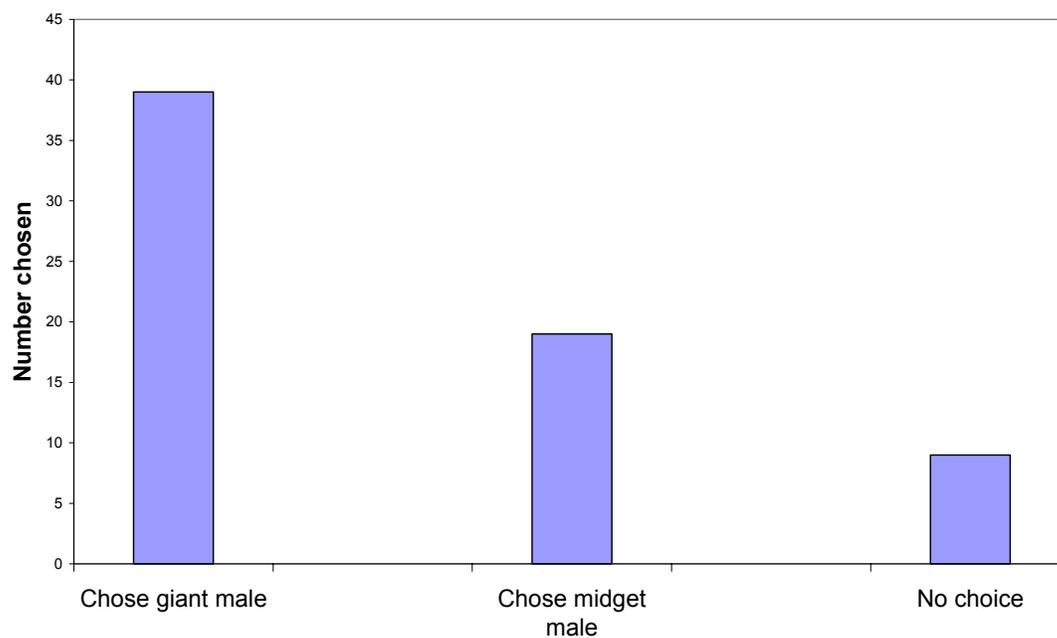

Figure 3.3. Results of mate-choice tests for *Evarcha culicivora* females. Chose giant significantly more often than midget conspecific males.

CHAPTER 4

ODOUR-MEDIATED DECISIONS BY *EVARCHA CULICIVORA*, A MOSQUITO-EATING JUMPING SPIDER (ARANEAE: SALTICIDAE) FROM EAST AFRICA

In experiments using a Y-shaped olfactometer, *Evarcha culicivora*, a salticid that preys by preference on blood-fed female mosquitoes, made odour-based choices between prey types, plant types and mate types. Individuals of *E. culicivora* chose the odour of blood-fed *Anopheles gambiae* females significantly more often than they chose the odour of *A. gambiae* males or unfed *A. gambiae* females (Experiment 1). They also chose odour of *Lantana camara* flowers and the odour of *Ricinus communis* flowers significantly more than they chose odour of *Striga hermonthica* flowers (Experiment 2). The odour of opposite-sex conspecifics was chosen by *E. culicivora* significantly more often than the odour of same-sex conspecifics (Experiment 3). *E. culicivora* females and males more often chose potential mates that had been on a mixed diet of lake flies and blood-fed *A. gambiae* females rather than potential mates that had been on a diet of lake flies alone, *A. gambiae* males alone or unfed *A. gambiae* females alone (Experiment 4). *E. culicivora* also chose the odours of potential mates more often when these mate odours were coupled with the odours of blood-fed *A. gambiae* females or of *L. camara* flowers rather than when coupled with the odour of *A. gambiae* males, lake flies or *S. hermonthica* flowers (Experiment 5). The relevance of sensory exploitation in understanding *E. culicivora*'s mate-choice behaviour is discussed.

Salticids have unique, complex eyes and visual acuity that is exceptional for animals of their size (Harland & Jackson, 2000). Because they can see so well, visual cues tend to dominate many aspects of these animals' lives, and visual cues might be expected to have a primary role in salticid mate-choice behaviour (see Jackson & Pollard, 1997). However, earlier studies have shown that tactile cues and chemical cues also influence salticid mate-searching, prey-searching, courtship and predatory behaviour (Pollard et al., 1987; Taylor,

1998). Chemoreception, including olfaction, is widely envisaged as the most primitive sensory modality used by animals (Freeman, 1999; Davis & Ludvigson, 1995). It is interesting that salticids, despite their small size, show no suggestion of there having been a trade-off in the evolution of sensory systems. Among spiders, only salticids have acute vision. All spiders apparently rely on chemoreception and on tactile sensory systems, but there is no evidence that suggests salticids are any less effective than other spiders at using these alternatives to vision (Jackson & Pollard, 1996; Jackson & Pollard, 1997). This chapter differs from earlier studies because I investigate the interplay of olfactory cues from food sources and from potential mates, and I consider mate-choice in particular, rather than mate searching and courtship.

E. culicivora is a unique salticid because its preferred, but not exclusive, food is blood from female mosquitoes (Pain, 2002). Moreover, this salticid supplements its blood diet by feeding on other insects and on nectar. Recent research has shown that many salticids feed on nectar (Jackson et al., 2001), but *E. culicivora* is unusual because its biology appears to be tightly linked with particular plants, *Lantana camara* and *Ricinus communis*. Something else is unusual about *E. culicivora*. Generally it is the early juvenile instars of salticids that feed on nectar (Jackson et al., 2001), but all stages (including adults) of *E. culicivora* feed on the nectar of *L. camara* and *R. communis*.

Earlier work (Chapter 2) suggested that *R. communis* and *L. camara* flowers serve as meeting places for courting and mating. Here, I consider whether *E. culicivora* is attracted to odours specifically from its preferred insect prey and preferred plant species, and whether *E. culicivora*'s courtship and mate-choice behaviour are influenced by the odour of *L. camara*, *R. communis* and blood-fed mosquitoes.

In this chapter, I consider five hypotheses: (1) *E. culicivora* is attracted specifically to the odour of its preferred prey (i.e., *E. culicivora* distinguishes the odour of blood-fed mosquito females from the odour of mosquito males and unfed mosquito females); (2) *E. culicivora* is attracted specifically to the odour of its preferred plants (i.e., *E. culicivora* distinguishes the odour of *Ricinus communis* and *Lantana camara* from the odour of a control plant, *Striga hermonthica*); (3) *E. culicivora* males and females are attracted to the odour of opposite-sex conspecific individuals (i.e., *E. culicivora* distinguishes between the odours of same- and opposite-sex conspecifics); (4) *E. culicivora* males and females acquire diet-induced odours that attract opposite-sex conspecific individuals; (5) *E. culicivora* males and females are attracted more strongly to the odour of an opposite-sex *E. culicivora* when *E. culicivora*'s odour is combined with odour from *L. camara* or with the odour of blood-fed mosquitoes.

Materials and Methods

A Y-shaped olfactometer (Fig. 4.1) with airflow adjusted to 1500 ml/min (Matheson FM-1000 flowmeter) was used to assess *E. culicivora*'s response to specific odours. There was no evidence that this airflow setting impaired locomotion or had any other adverse effects on *E. culicivora*'s behaviour. Air was pushed by a pump from a tap through two separate flowmeters into two chambers, a stimulus chamber and a control chamber. The stimulus chamber contained one of three types of odour: from prey, from flowers or from conspecifics. The prey odours came from *Anopheles gambiae* females that had recently fed on blood, unfed *A. gambiae* females, *A. gambiae* males or lake flies, whereas the flower odour came each time from the flowers of *L. camara*, from *R. communis*, or from another

plant, *S. hermonthica*, used as a control. *S. hermonthica* (commonly known as the African witchweed) also occurs in *E. culicivora*'s habitat (Parker & Riches, 1993), but it does not appear to be linked as tightly to *E. culicivora*'s biology as *R. communis* and *L. camara* are. The 'conspecific odours' came each time from an adult male or an adult female of *E. culicivora*. Unless stated otherwise, the diet of the males or females of *E. culicivora* used as an odour source was a mixed diet that included blood-fed *A. gambiae* females. The spider was always an individual that had not mated ('virgin'; unless stated otherwise), and it was tested only once.

In some tests, the control chamber was empty. In other tests, the control chamber contained an odour source different from that in the stimulus chamber. For each test, whether the stimulus chamber was on the left or right side of the olfactometer was decided at random. Air moved from the stimulus chamber to the stimulus arm, and independently from the control chamber to the control arm. Collectively, the two are referred to as the 'choice arms'. Air moved from the two choice arms into the 'test arm' (i.e., the stem of the Y). There was a test spider in a holding chamber at the far end of the test arm. Any item used for an odour source was placed in the stimulus chamber 30 min before each test. This 30 min period allowed air to circulate evenly and ensured that air pressure was comparable throughout the olfactometer. A removable metal grill fit into a slit in the chamber roof, blocking access between the test arm and the holding chamber. The grill was lifted to start a test. The test spider was always an adult male or a female, and all test spiders were virgin (i.e., individuals that had not mated) that reached maturity 7–14 days before tested.

In Experiment 1, the test spiders were given a choice between the odour of blood-fed *A. gambiae* females and odour of *A. gambiae* males (*E. culicivora* males, $n = 29$; *E.*

culicivora females $n = 52$) or unfed *A. gambiae* females (*E. culicivora* males, $n = 43$; *E. culicivora* females, $n = 37$). In Experiment 2, the test spiders were given a choice between the odour of *L. camara* flowers and control of no odour (*E. culicivora* males, $n = 53$; *E. culicivora* females $n = 47$), odour of *S. hermonthica* flowers and control of no odour (*E. culicivora* males, $n = 41$; *E. culicivora* females $n = 47$), odour of *L. camara* flowers and odour of *S. hermonthica* flowers (*E. culicivora* males, $n = 55$; *E. culicivora* females $n = 51$) or odour of *R. communis* flowers and odour of *S. hermonthica* flowers (*E. culicivora* males, $n = 40$; *E. culicivora* females $n = 46$). In Experiment 3, *E. culicivora* males chose between the odour of virgin *E. culicivora* females and control of no odour ($n = 51$), the odour of mated *E. culicivora* females and control of no odour ($n = 42$) or the odour of virgin *E. culicivora* males and control of no odour ($n = 50$). *E. culicivora* females in Experiment 3 chose between the odour of virgin *E. culicivora* males and control of no odour ($n = 45$), the odour of virgin *E. culicivora* females and control of no odour ($n = 36$) or the odour of mated *E. culicivora* females and control of no odour ($n = 46$). In Experiment 4, test spiders chose between the odour of opposite-sex conspecifics on a mixed diet that included blood-fed *A. gambiae* females and the odour of opposite-sex conspecifics that had been on one of three prior diets: lake flies only (*E. culicivora* males, $n = 68$; *E. culicivora* females $n = 66$), *A. gambiae* males only (*E. culicivora* males, $n = 38$; *E. culicivora* females $n = 71$) or unfed *A. gambiae* females only (*E. culicivora* males, $n = 42$; *E. culicivora* females $n = 86$). In Experiment 5, test spiders chose between the odour of opposite-sex conspecifics paired with the odour of blood-fed *A. gambiae* females and either the odour opposite-sex conspecifics paired with the odour of *A. gambiae* males (*E. culicivora* males, $n = 47$; *E. culicivora* females $n = 44$) or the odour opposite-sex conspecifics paired with the odour of

lake flies (*E. culicivora* males, $n = 49$; *E. culicivora* females $n = 52$). *E. culicivora* females ($n = 57$) also chose between the odour of *E. culicivora* males paired with the odour of *L. camara* flowers and the odour of *E. culicivora* males paired with the odour of *S. hermonthica* flowers.

Spiders usually walked about actively in the olfactometer. After leaving the holding chamber, the spider was allowed 30 min to make a choice (definition: entered a choice arm and remained there for 30 s). The test spider's latency to choose and which of the two arms it chose was recorded. As a precaution against the potential effects of traces left by spiders that had been tested previously, the olfactometer was dismantled and cleaned with 80% ethanol and then with distilled water between tests. For this study, all data were analysed using chi-square tests for goodness of fit (null hypothesis: probability of making one of the two choices same as making probability of making other choice) (see Howell, 2002). For data analysis, individuals that failed to choose were ignored.

Results

Odour-mediated prey choice

When given a choice between the odour of blood-fed *A. gambiae* females and odour of a different type of prey (*A. gambiae* males or unfed *A. gambiae* females), males and females of *E. culicivora* chose the odour of blood-fed *A. gambiae* females significantly more often than the odour of *A. gambiae* males (*E. culicivora* males: $\chi^2 = 11.571$, $p < 0.001$, Fig. 4.2; *E. culicivora* females: $\chi^2 = 9.909$, $p < 0.01$, Fig. 4.3) or unfed *A. gambiae* females (*E. culicivora* males: $\chi^2 = 25.973$, $p < 0.001$, Fig. 4.4; *E. culicivora* females: $\chi^2 = 18.939$, $p < 0.001$, Fig. 4.5).

Odour-mediated plant choice

E. culicivora males ($\chi^2 = 10.256$, $p < 0.01$, Fig. 4.6) and females ($\chi^2 = 4.900$, $p < 0.05$, Fig. 4.7) chose the odour of *L. camara* flowers significantly more often than they chose the control (no odour), and neither males ($\chi^2 = 0.182$, ns, Fig. 4.8) nor females ($\chi^2 = 1.125$, ns, Fig. 4.9) chose the odour of *S. hermonthica* significantly more than they chose the control (no odour). *E. culicivora* males ($\chi^2 = 6.737$, $p < 0.01$; Fig. 4.10) and females ($\chi^2 = 7.258$, $p < 0.01$; Fig. 4.11) chose the odour of *L. camara* flowers significantly more often than they chose the odour of *S. hermonthica* flowers, and males ($\chi^2 = 4.800$, $p < 0.05$; Fig. 4.12) and females ($\chi^2 = 8.805$, $p < 0.01$; Fig. 4.13) chose the odour of *R. communis* flowers significantly more often than they chose the odour of *S. hermonthica* flowers.

Odour-mediated sex discrimination

E. culicivora males chose the odour of virgin ($\chi^2 = 17.781$, $p < 0.001$; Fig. 4.14) and of mated *E. culicivora* females ($\chi^2 = 12.565$, $p < 0.001$; Fig. 4.15) significantly more often than they chose the control (no odour). *E. culicivora* females chose the odour of *E. culicivora* virgin males ($\chi^2 = 11.11$, $p < 0.001$, Fig. 4.16) significantly more often than the control (no odour). However, there was no significant difference in how often males chose the odour of other *E. culicivora* males ($\chi^2 = 0.100$, ns, Fig. 4.17) or females chose the odour of other females (virgin: $\chi^2 = 1.190$, ns, Fig. 4.18; mated: $\chi^2 = 1.500$, ns, Fig. 4.19) rather than the control (no odour).

Odour-mediated mate-choice

E. culicivora males and females discriminated between opposite-sex individuals that had been maintained previously on different diets. They chose the odour of opposite-sex individuals that had been on a mixed diet that included blood-fed *A. gambiae* females significantly more often than they chose odour of opposite-sex individuals that had been on a diet of lake flies only (*E. culicivora* males, $\chi^2 = 9.931$, $p < 0.01$, Fig. 4.20; *E. culicivora* females, $\chi^2 = 8.805$, $p < 0.01$, Fig. 4.21), *A. gambiae* males only (*E. culicivora* males, $\chi^2 = 9.966$, $p < 0.01$, Fig. 4.22; *E. culicivora* females, $\chi^2 = 13.520$, $p < 0.001$, Fig. 4.23) or unfed *A. gambiae* females only (*E. culicivora* males, $\chi^2 = 9.524$, $p < 0.01$, Fig. 4.24; *E. culicivora* females, $\chi^2 = 11.077$, $p < 0.001$, Fig. 4.25).

Influence of prey odour on mate-choice

E. culicivora significantly more often chose the odour of opposite-sex individuals (maintained on a diet of *A. gambiae* males only or a diet of lake flies only) when paired with the odour of blood-fed *A. gambiae* females rather than when paired with the odour of *A. gambiae* males (*E. culicivora* males: $\chi^2 = 27.222$, $p < 0.001$, Fig. 4.26; *E. culicivora* females: $\chi^2 = 21.113$, $p < 0.001$, Fig. 4.27) or when paired with the odour of lake flies (*E. culicivora* males: $\chi^2 = 24.381$, $p < 0.001$, Fig. 4.28; *E. culicivora* females: $\chi^2 = 18.667$, $p < 0.001$, Fig. 4.29).

Influence of plant odour on mate-choice

E. culicivora females chose the odour of *E. culicivora* males paired with the odour of *L. camara* flowers significantly more often than they chose the odour of *E. culicivora* males

(on a diet of *A. gambiae* males) paired with the odour of *S. hermonthica* flowers ($\chi^2 = 19.612, p < 0.001$; Fig. 4.30).

Discussion

Earlier studies have shown that *E. culicivora* preys by preference on blood-fed female mosquitoes, and that for *E. culicivora* optical cues alone are sufficient for selecting prey (Nelson & Jackson, unpublished data). The present study shows that *E. culicivora* can also select its preferred prey by odour alone (Experiment 1). Furthermore, the present study shows that *E. culicivora* can select its preferred plants (*R. communis* and *L. camara*) by odour alone (Experiment 2). However, conclusions from Experiments 1 and 2 are based on only limited controls (only one mosquito species was used in Experiment 1 and only one control plant species was used in Experiment 2). These experiments need to be extended by using more mosquito species, more alternative prey types for controls and more plant species for control flowers.

Experiment 3 showed that males and females both distinguish the odour of opposite-sex conspecifics from the odour of same-sex conspecifics. Although this is the first study to explore odour-based sex discrimination in a salticid, there are many comparable studies using insects showing sex discrimination by odour (Thornhill & Alcock, 1983). However, other studies have explored the use of pheromones (Pollard et al., 1987) in salticid mate-searching behaviour. For example, males of a New Zealand salticid, *Trite planiceps*, preferentially associate with areas where draglines have been deposited by conspecific females rather than areas lacking draglines (Taylor, 1998), but these findings were different because the cues from *T. planiceps* were of a different type

(contact chemical cues, rather than olfactory cues) and had a different origin (from silk, a product of the spider, rather than the spider itself).

This is also the first study to show that a particular diet makes the odour of a salticid more attractive to opposite-sex conspecific individuals (Experiment 4). It is interesting that these unusual links between diet, odour and attraction of the opposite sex have been found in *E. culicivora*, a salticid with an unprecedented preference for a very specific type of prey insect, blood-fed female mosquitoes. Feeding on blood-fed female mosquitoes appears to amplify the attractiveness of opposite-sex individuals of *E. culicivora*, suggesting that the evolution of *E. culicivora*'s unusual diet may have been driven in part by intersexual selection (i.e., for adult males and adult females of *E. culicivora*, part of the adaptive significance of feeding on blood may be ability to gain enhanced attractiveness to opposite-sex conspecific individuals). More specifically, sensory exploitation (see (Endler & Basolo, 1998) may be relevant. *E. culicivora*'s feeding biology suggests that *E. culicivora* might have a predisposition to respond positively to cues from mosquito-derived blood, with this predisposition having originated in a context different from mate choice.

Diet effects related to mate choice are known for vertebrates. For example, red-backed salamander (*Plethodon cinereus*) females prefer spending time in a burrow near a faecal pellet from a male on a high-quality diet, rather than in a burrow near a faecal pellet from the same male on a low-quality diet (Walls et al., 1989). In the meadow vole (*Microtus pennsylvanicus*), both males and females prefer odours derived from the anogenital area, urine and faeces of potential mates on high-protein diets, rather than odours derived from the anogenital area, urine and faeces of potential mates on lower-

protein diets (Ferkin et al., 1997). Ferkin et al. (1997) argued that choosing a mate on a high-quality diet is a means of choosing a higher-quality individual, and this argument might apply to *E. culicivora* as well. Other work (Jackson, unpublished data) has shown that a mixed diet that includes mosquito-derived blood enables *E. culicivora* to achieve larger body size and lay more eggs. For meadow voles and for *E. culicivora*, choosing larger opposite-sex individuals as mates may be advantageous specifically by enabling the individual that does the choosing to have higher-quality offspring as a consequence of offspring inheriting the chosen mate's proven ability to gain an optimal diet. Studies on heritability would be useful for testing this hypothesis.

E. culicivora also chose the odour of an opposite-sex conspecific more often when that conspecific was presented with a particular outside odour (either blood-fed *A. gambiae* females or *L. camara*; Experiment 5). This suggests that both of these odours (that of mosquito-derived blood and that of *L. camara* flowers) enhance *E. culicivora*'s attractiveness to potential mates. Evidently, besides blood-fed mosquitoes and nectar from *L. camara* being important parts of *E. culicivora*'s diet, these two dietary sources are also important factors in *E. culicivora*'s mate-choice behaviour (i.e., odours from these two sources appear to amplify *E. culicivora*'s attractiveness to potential mates). Something similar may apply to euglossine bees. Males of these bees are more attractive to females when odours from orchid flowers on which the bees feed adhere to the males' bodies (Lunau, 1992). The female bee's predisposition to respond to the orchid odour presumably evolved in the context of feeding and is being exploited by the male bee in a different context (i.e., mate attraction). There is an interesting difference, however. For *E. culicivora*, odours from an insect prey and from a plant may both independently make

spiders attractive to the opposite sex, whereas for the bees only one outside odour source (flowers) is known to be exploited.

References

- Davis, S. F., & Ludvigson, H. W. (1995). Odor memory in nonhumans. In F. R. Schab & R. G. Crowder (Eds.), *Memory for odors* (pp. 133-158). Mahwah, New Jersey: Lawrence Erlbaum Associates, Inc.
- Endler, J. A., & Basolo, A. L. (1998). Sensory ecology, receiver biases and sexual selection. *Trends in Ecology & Evolution*, *13*(10), 415-420.
- Ferkin, M. H., Sorokin, E. S., Johnston, R. E., & Lee, C. J. (1997). Attractiveness of scents varies with protein content of the diet in meadow voles. *Animal Behaviour*, *53*(1), 133-141.
- Freeman, W. J. (1999). *How brains make up their minds*. London: Phoenix.
- Harland, D. P., & Jackson, R. R. (2000). 'Eight-legged cats' and how they see - a review of recent research on jumping spiders (Araneae: Salticidae). *Cimbebasia*, *16*, 231-240.
- Howell, D. C. (2002). *Statistical methods for psychology* (5th ed.). Belmont, California: Wadsworth.
- Jackson, R. R., & Pollard, S. D. (1996). Predatory behavior of jumping spiders. *Annual Review of Entomology*, *41*, 287-308.
- Jackson, R. R., & Pollard, S. D. (1997). Jumping spider mating strategies: sex among cannibals in and out of webs. In J. C. Choe & B. J. Crespi (Eds.), *The evolution of mating systems in insects and arachnids*. (pp. 340-351). Cambridge: Cambridge University Press.

- Jackson, R. R., Pollard, S. D., Nelson, X. J., Edwards, G. B., & Barrion, A. T. (2001). Jumping spiders (Araneae: Salticidae) that feed on nectar. *Journal of Zoology*, 255(1), 25-29.
- Lunau, K. (1992). Evolutionary aspects of perfume collection in male euglossine bees (Hymenoptera) and of nest deception in bee-pollinated flowers. *Chemoecology*, 3(2), 65-73.
- Pain, S. (2002). Bloodlust. *New Scientist*, 176(2373), 44-47.
- Parker, C., & Riches, C. R. (1993). *Parasitic plants of the world: biology and control*. Wallingford: CAB International.
- Pollard, S. D., Macnab, A. M., & Jackson, R. R. (1987). Communication with chemicals: pheromones and spiders. In W. Nentwig (Ed.), *Ecophysiology of spiders*. (pp. 133-141). Berlin: Springer-Verlag.
- Taylor, P. W. (1998). Dragline-mediated mate-searching in *Trite planiceps* (Araneae, Salticidae). *Journal of Arachnology*, 26(3), 330-334.
- Thornhill, R., & Alcock, J. (1983). *The evolution of insect mating systems*. Cambridge, Massachusetts: Harvard University Press.
- Walls, S. C., Mathis, A., Jaeger, R. G., & Gergits, W. F. (1989). Male salamanders with high-quality diets have faeces attractive to females. *Animal Behaviour*, 38(3), 546-548.

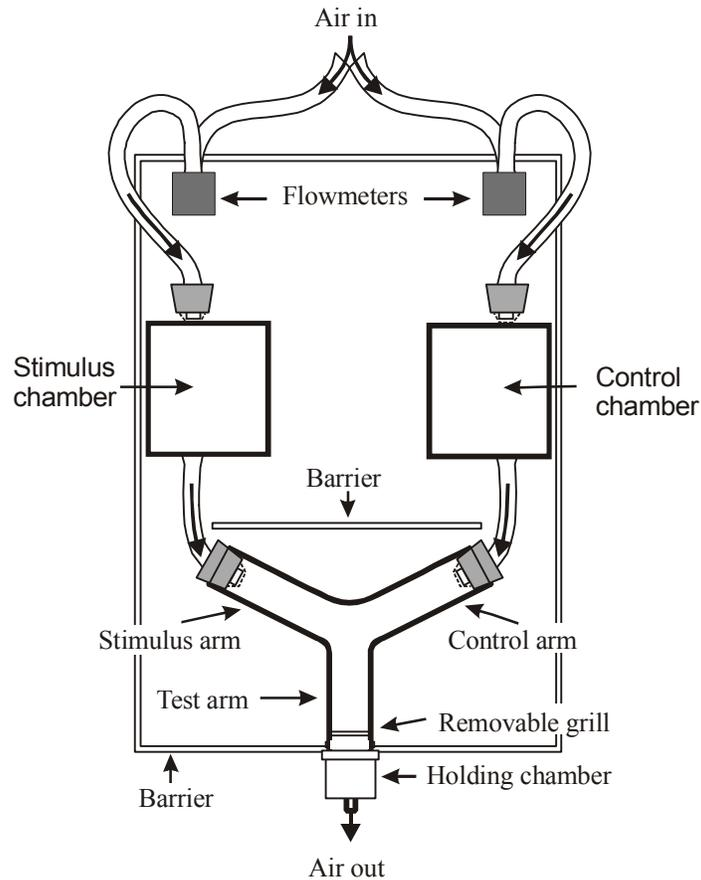

Figure 4.1. Olfactometer (not drawn to scale). Arrows indicate direction of airflow. Dimensions of rectangular stimulus chamber and of control chamber: 80 mm long \times 70 mm wide \times 80 mm high). Holding chamber (location of test spider at start of test): length 25 mm, internal diameter 25 mm. Start of test: test spider in holding chamber; grill removed, giving access to test arm, control arm and stimulus arm. Dimensions of test arm, control arm and stimulus arm: length 90 mm, internal diameter 20 mm. Opaque barriers prevent test spider from seeing odour source.

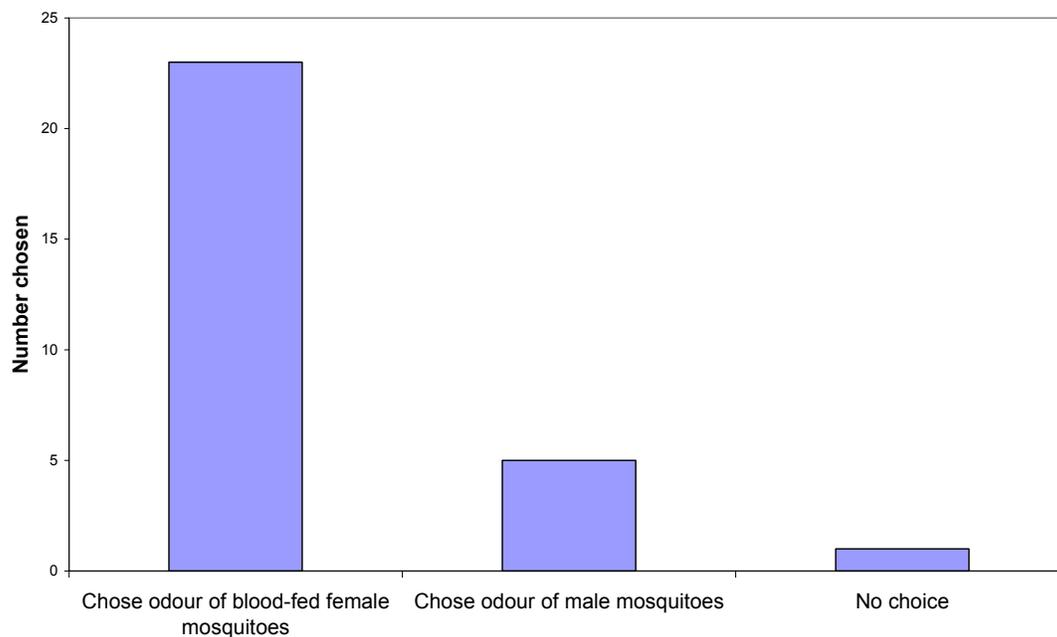

Figure 4.2. Results from testing *Evarcha culicivora* males in olfactometer showing odour of blood-fed *A. gambiae* females was chosen significantly more often than odour of *A. gambiae* males.

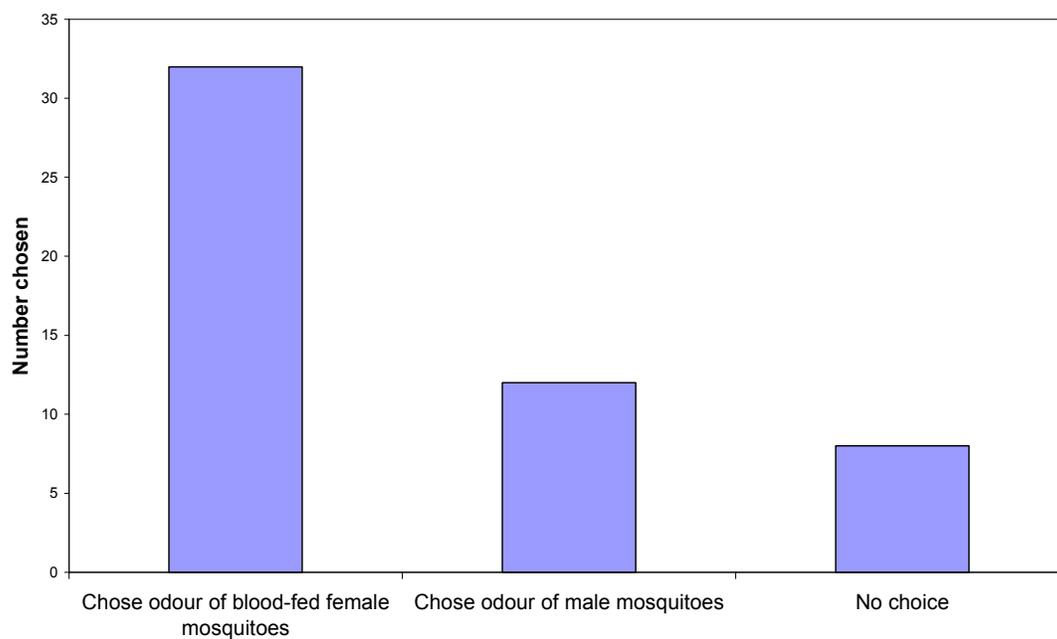

Figure 4.3. Results from testing *Evarcha culicivora* females in olfactometer showing odour of blood-fed *A. gambiae* females was chosen significantly more often than odour of *A. gambiae* males.

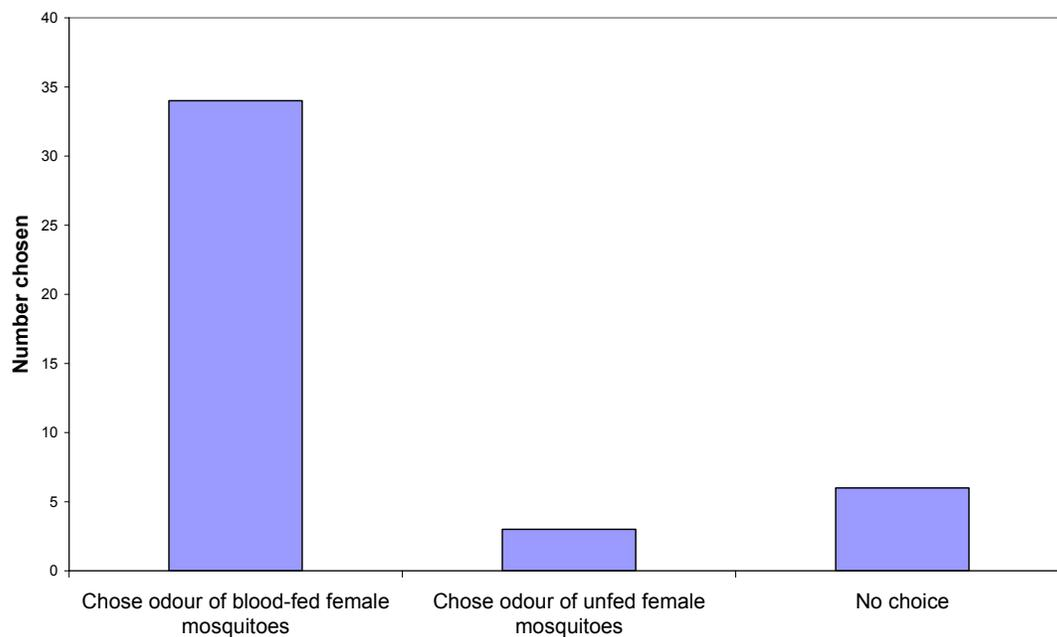

Figure 4.4. Results from testing *Evarcha culicivora* males in olfactometer showing odour of blood-fed *A. gambiae* females was chosen significantly more often than odour of unfed *A. gambiae* females.

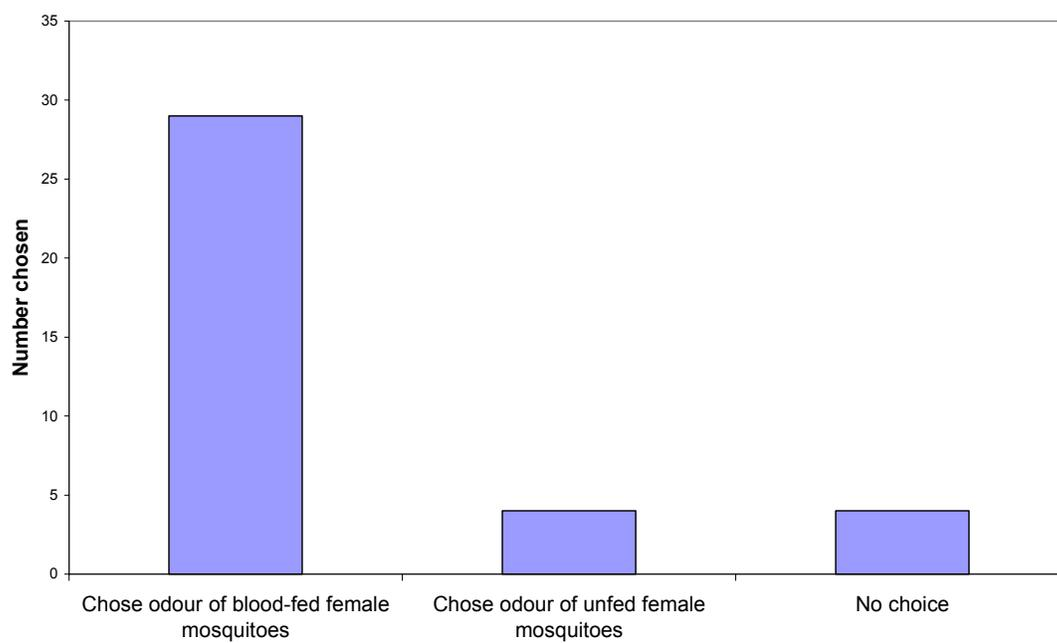

Figure 4.5. Results from testing *Evarcha culicivora* females in olfactometer showing odour of blood-fed *A. gambiae* females was chosen significantly more often than odour of unfed *A. gambiae* females.

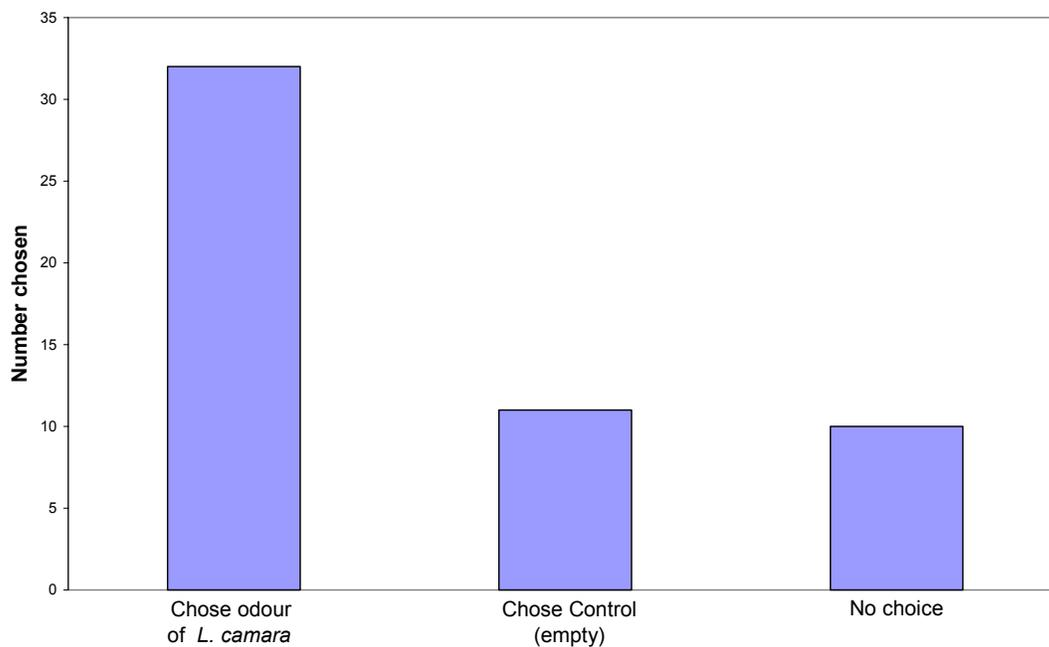

Figure 4.6. Results from testing *Evarcha culicivora* males in olfactometer showing odour of *L. camara* flowers was chosen significantly more often than control (no odour).

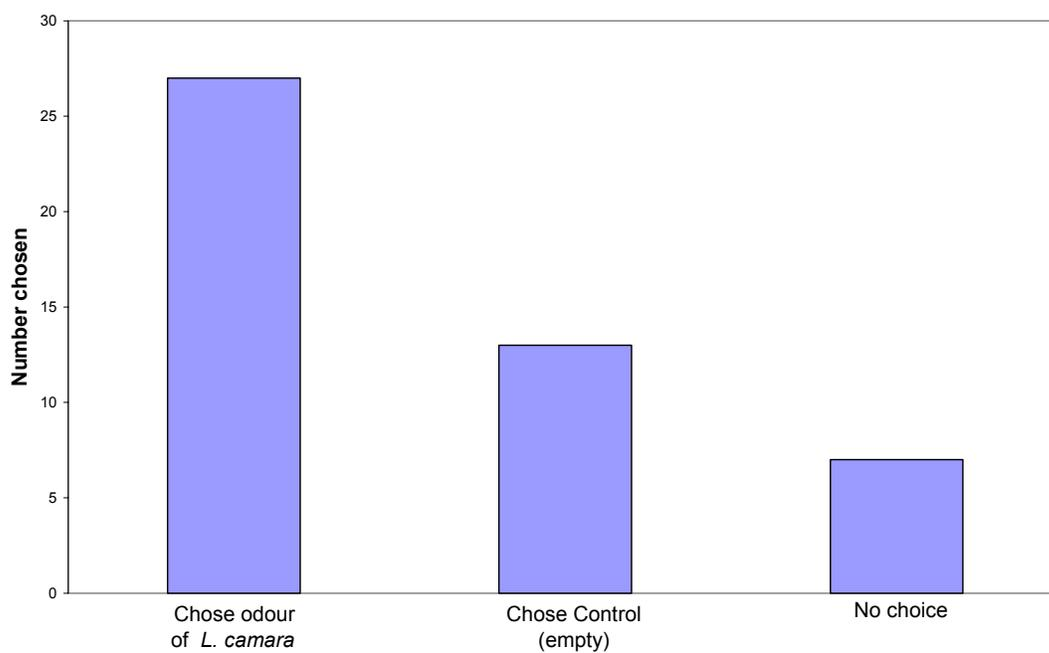

Figure 4.7. Results from testing *Evarcha culicivora* females in olfactometer showing odour of *L. camara* flowers was chosen significantly more often than control (no odour).

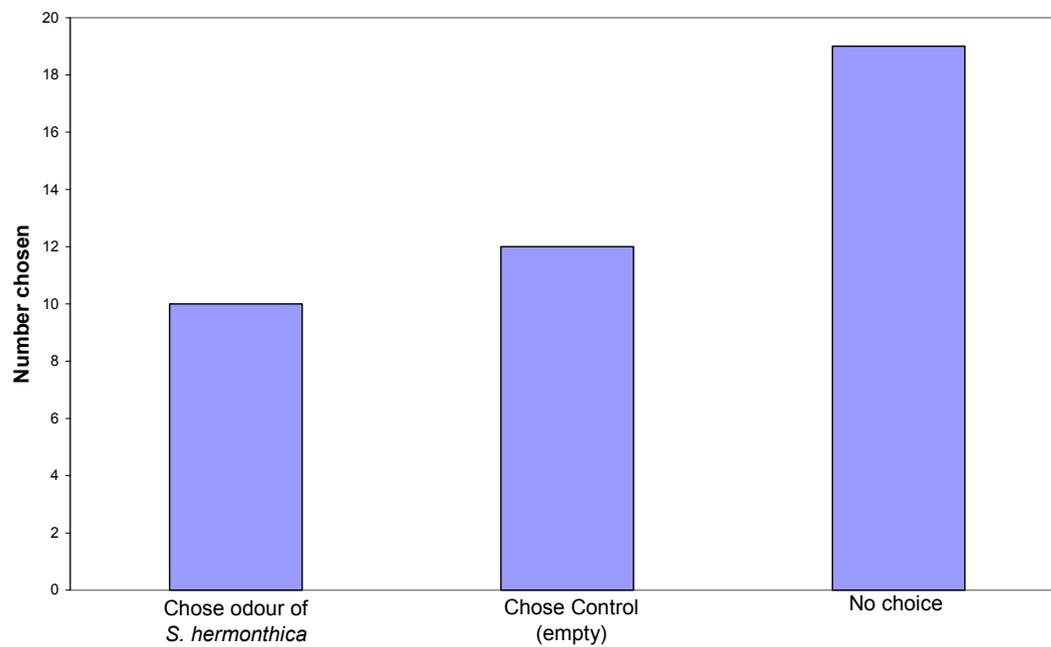

Figure 4.8. Results from testing *Evarcha culicivora* males in olfactometer. How often odour of *S. hermonthica* flowers was chosen was not significantly different from how often control (no odour) was chosen.

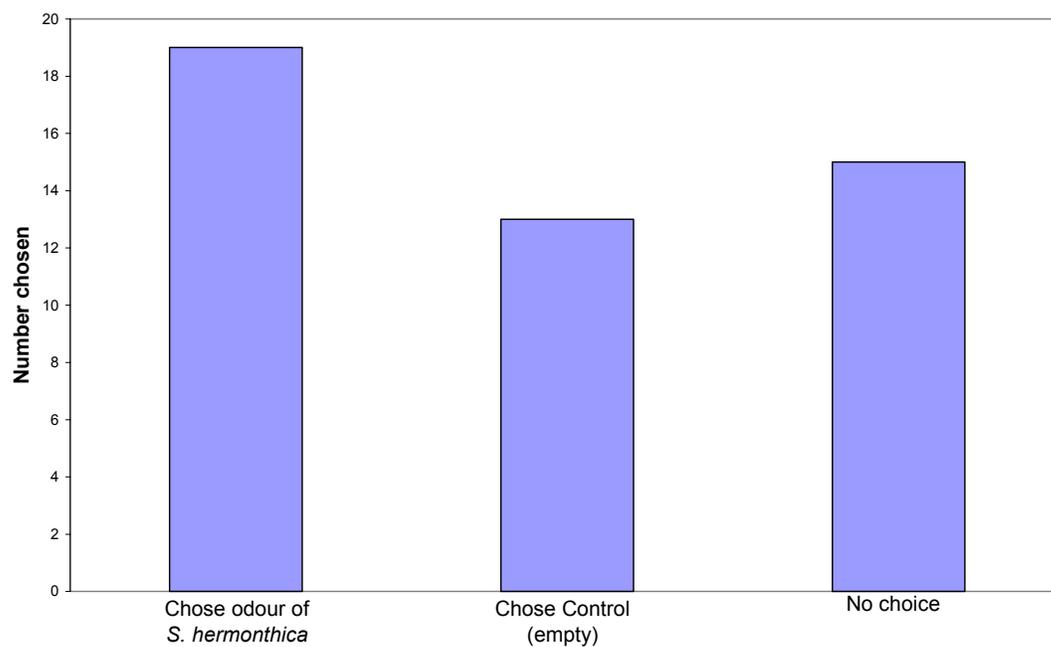

Figure 4.9. Results from testing *Evarcha culicivora* females in olfactometer. How often odour of *S. hermonthica* flowers was chosen was not significantly different from how often control (no odour) was chosen.

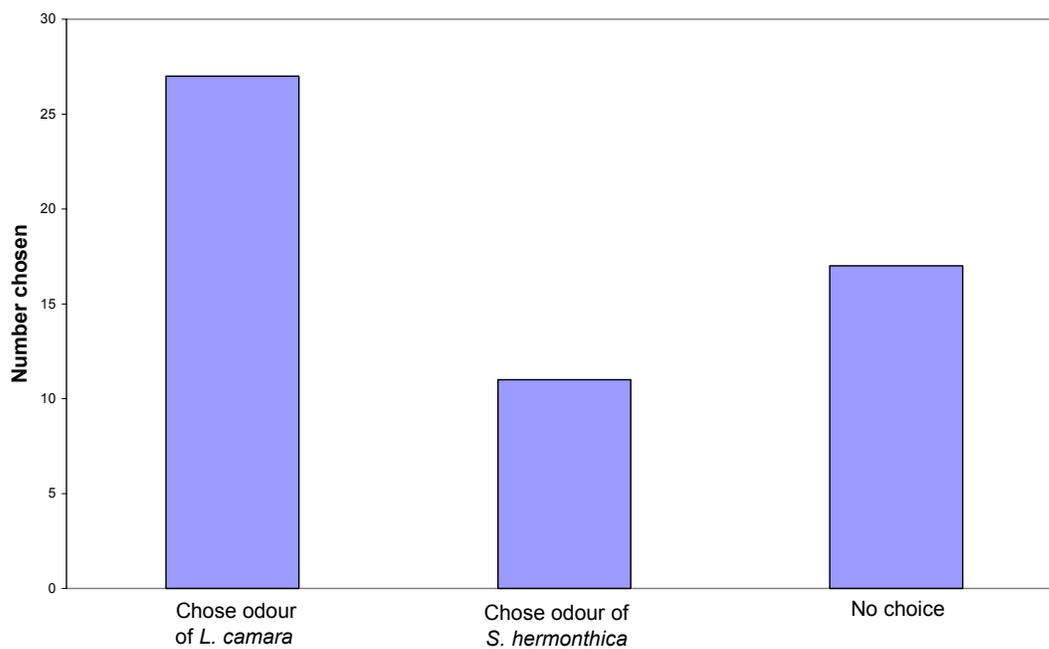

Figure 4.10. Results from testing *Evarcha culicivora* males in olfactometer showing odour of *L. camara* flowers was chosen significantly more often than odour of *S. hermonthica* flowers.

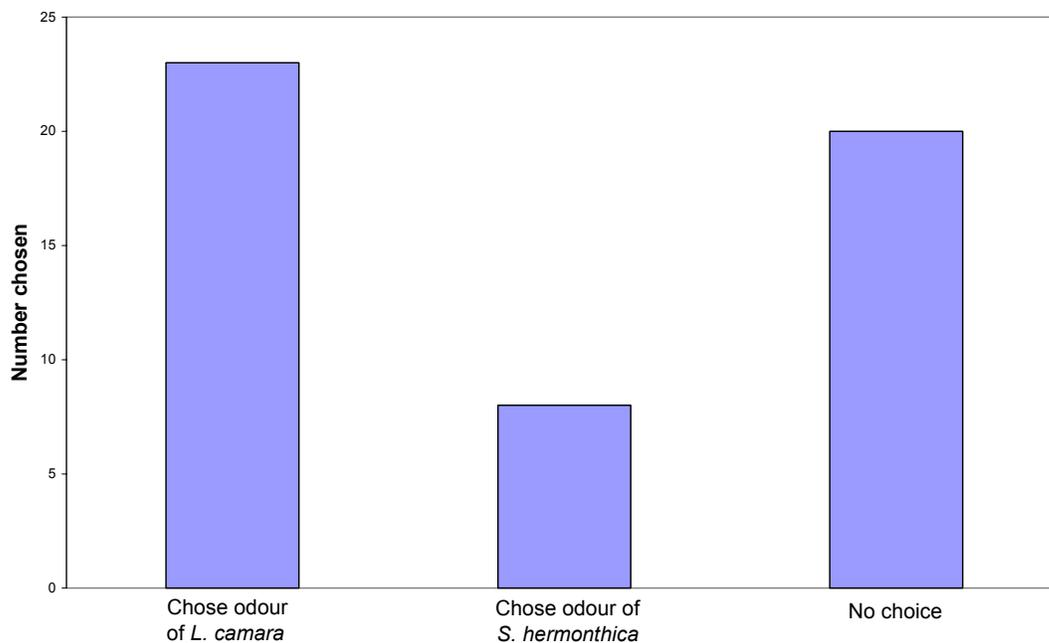

Figure 4.11. Results from testing *Evarcha culicivora* females in olfactometer showing odour of *L. camara* flowers was chosen significantly more often than odour of *S. hermonthica* flowers.

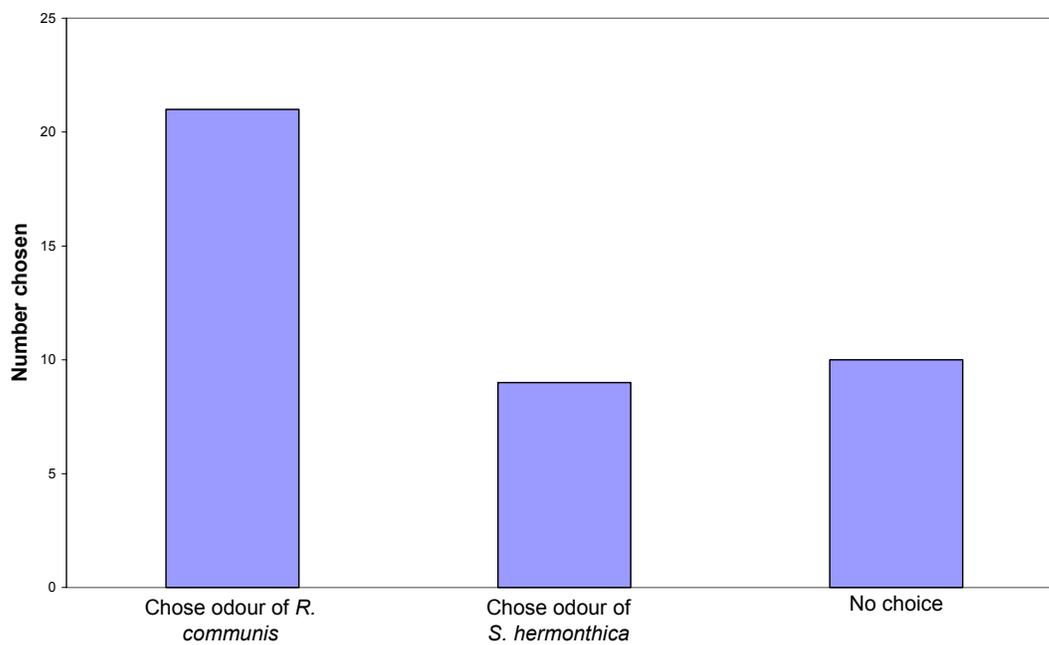

Figure 4.12. Results from testing *Evarcha culicivora* males in olfactometer showing odour of *R. communis* flowers was chosen significantly more often than odour of *S. hermonthica* flowers.

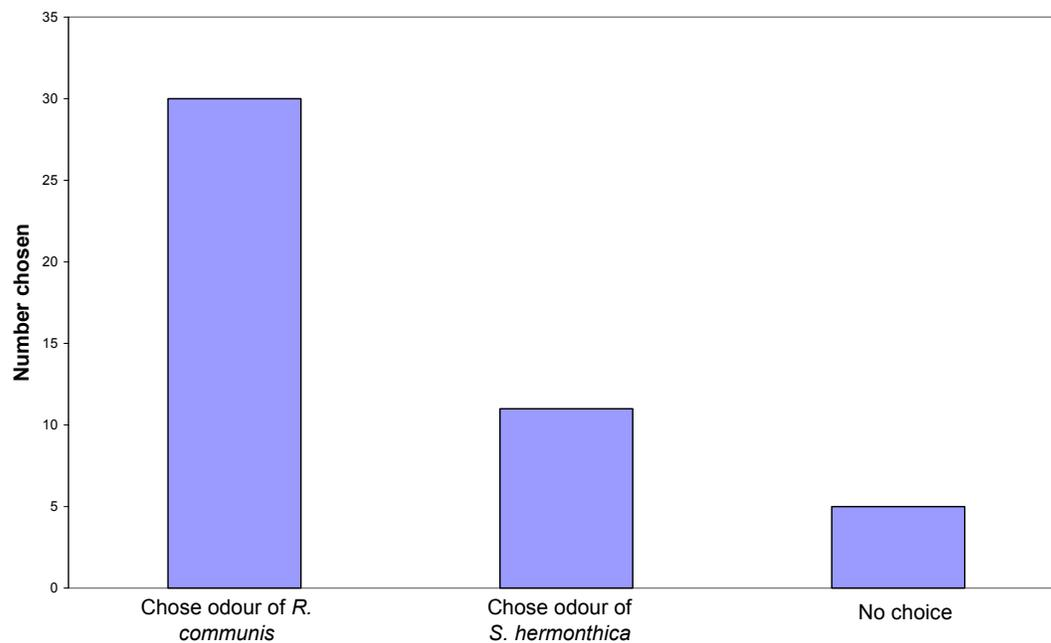

Figure 4.13. Results from testing *Evarcha culicivora* females in olfactometer showing odour of *R. communis* flowers was chosen significantly more often than odour of *S. hermonthica* flowers.

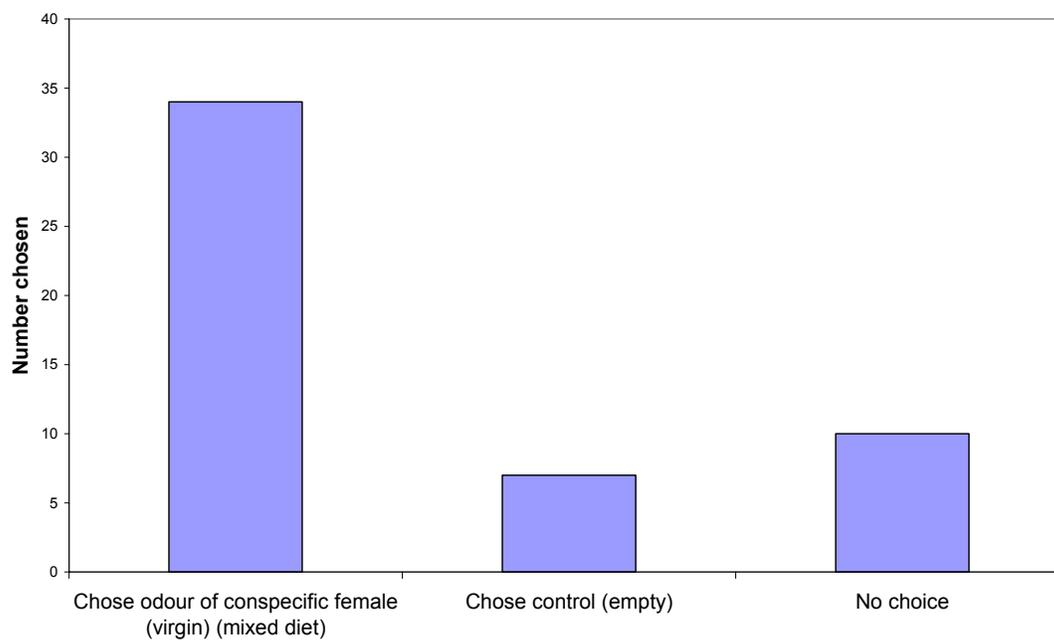

Figure 4.14. Results from testing *Evarcha culicivora* males in olfactometer showing odour of virgin *E. culicivora* females maintained on mixed diet was chosen significantly more often than control (no odour).

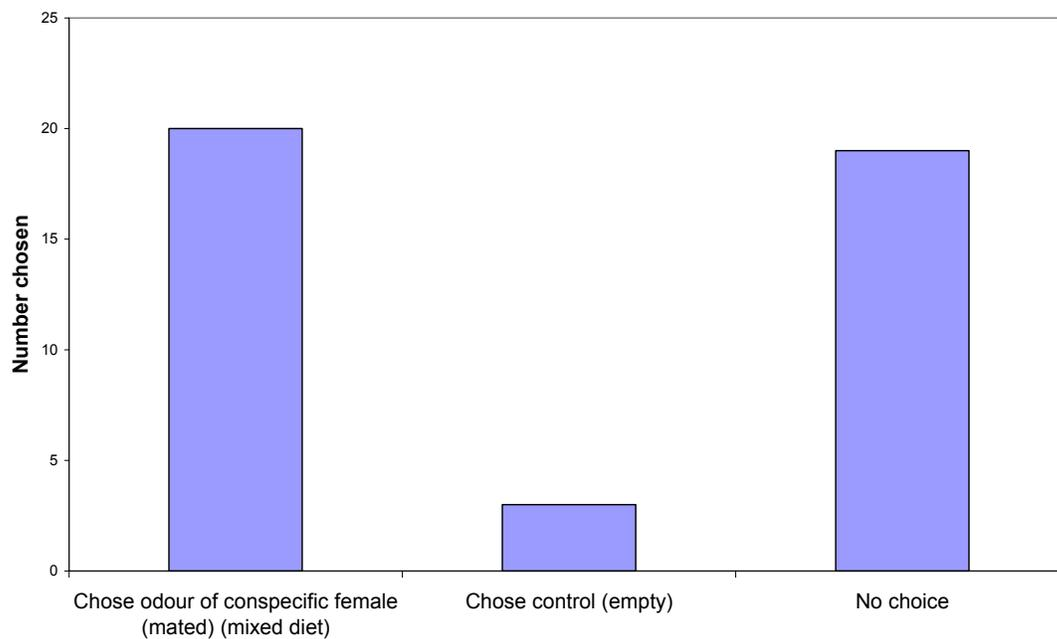

Figure 4.15. Results from testing *Evarcha culicivora* males in olfactometer showing odour of mated *E. culicivora* females maintained on mixed diet was chosen significantly more often than control (no odour).

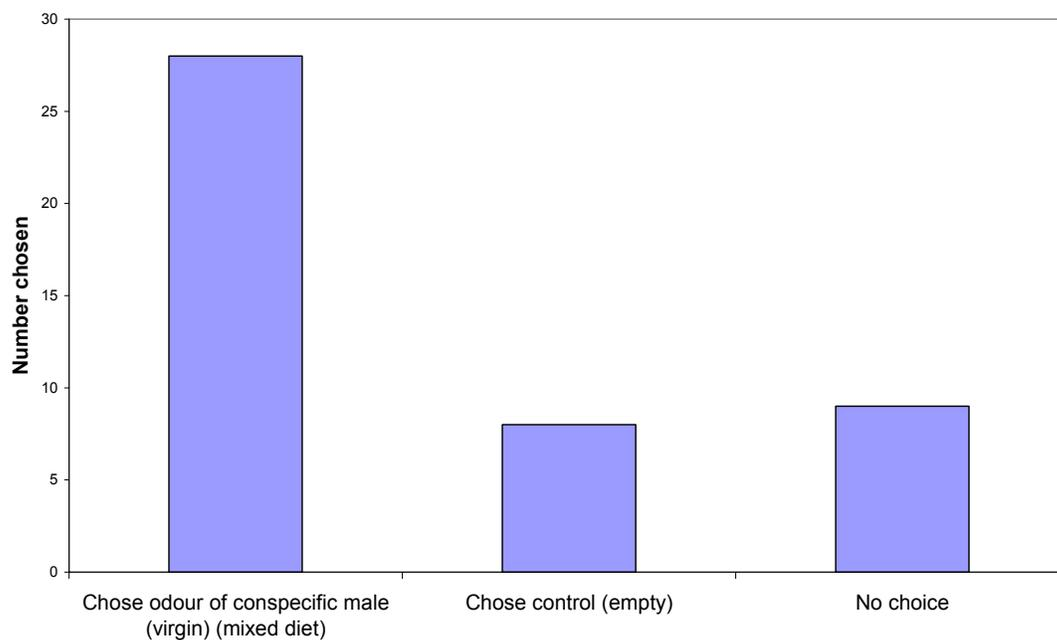

Figure 4.16. Results from testing *Evarcha culicivora* females in olfactometer showing odour of virgin *E. culicivora* males maintained on mixed diet was chosen significantly more often than control (no odour).

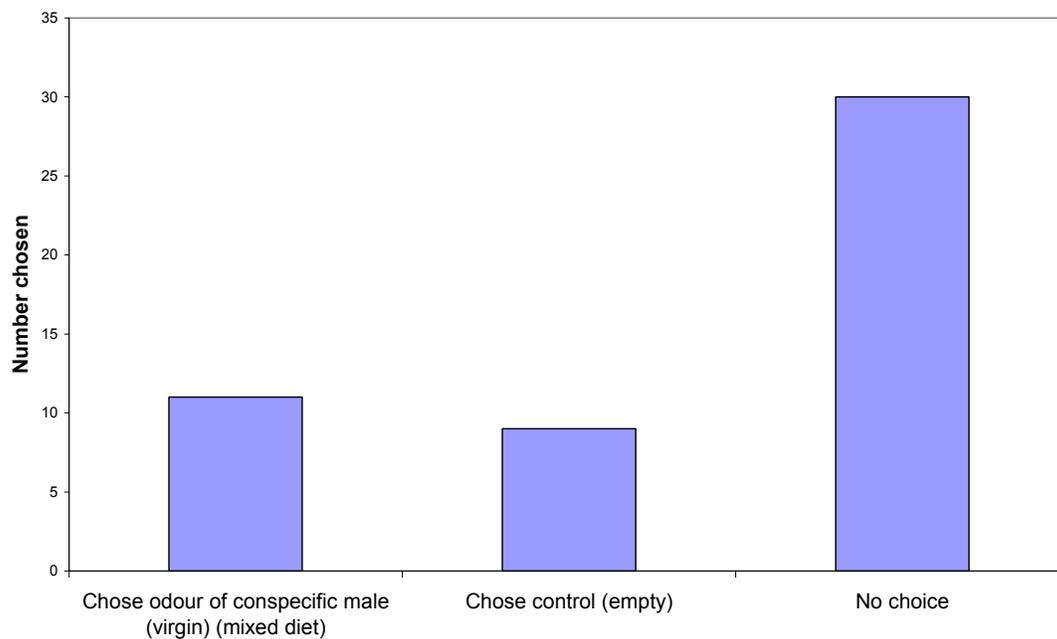

Figure 4.17. Results from testing *Evarcha culicivora* males in olfactometer. How often odour of virgin *E. culicivora* males maintained on mixed diet was chosen was not significantly different from how often control (no odour) was chosen.

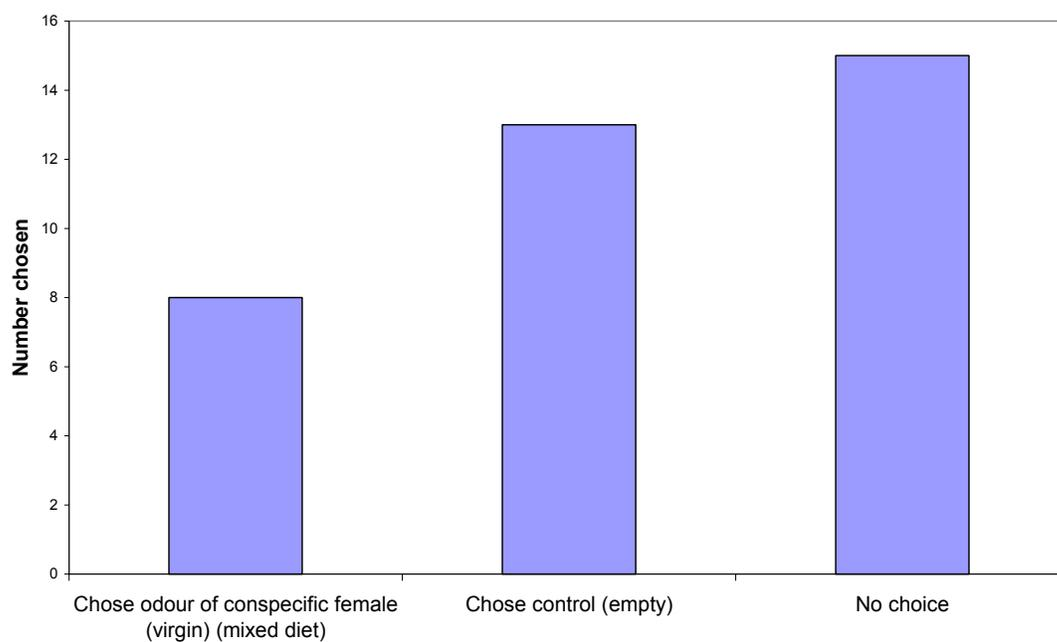

Figure 4.18. Results from testing *Evarcha culicivora* females in olfactometer. How often odour of virgin *E. culicivora* females maintained on mixed diet was chosen was not significantly different from how often control (no odour) was chosen.

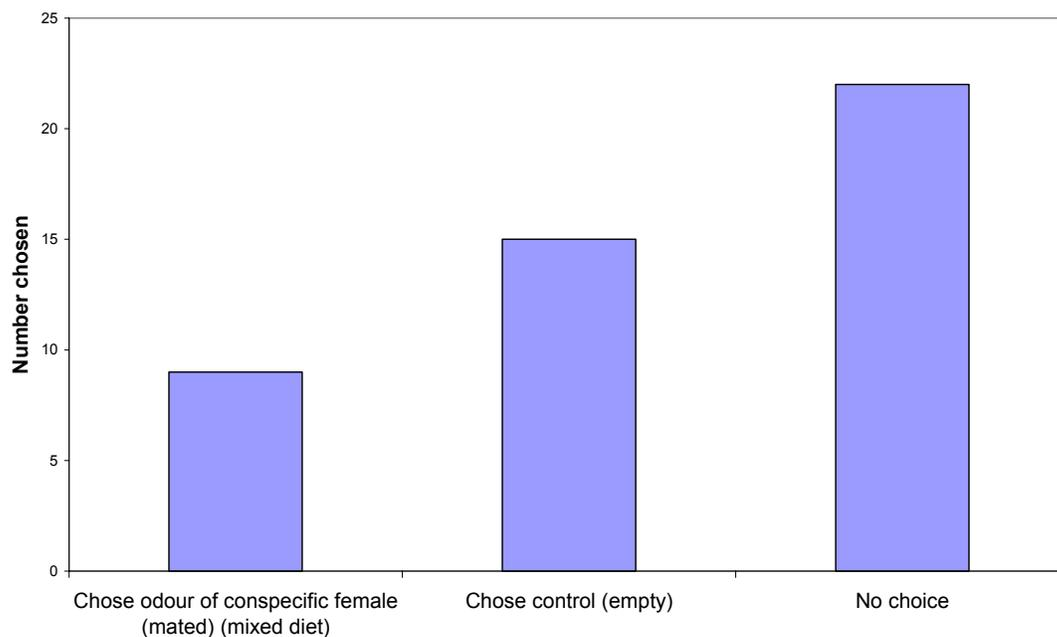

Figure 4.19. Results from testing *Evarcha culicivora* females in olfactometer. How often odour of mated *E. culicivora* females maintained on mixed diet was chosen was not significantly different from how often control (no odour) was chosen.

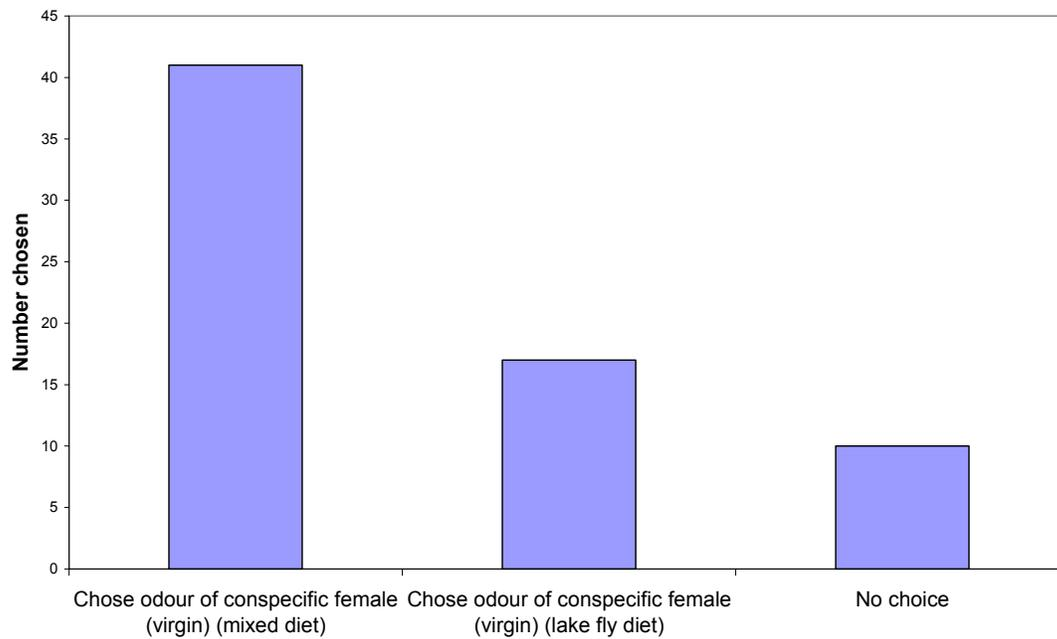

Figure 4.20. Results from testing *Evarcha culicivora* males in olfactometer showing odour of *E. culicivora* females maintained on mixed diet was chosen significantly more often than odour of *E. culicivora* females maintained on lake fly diet.

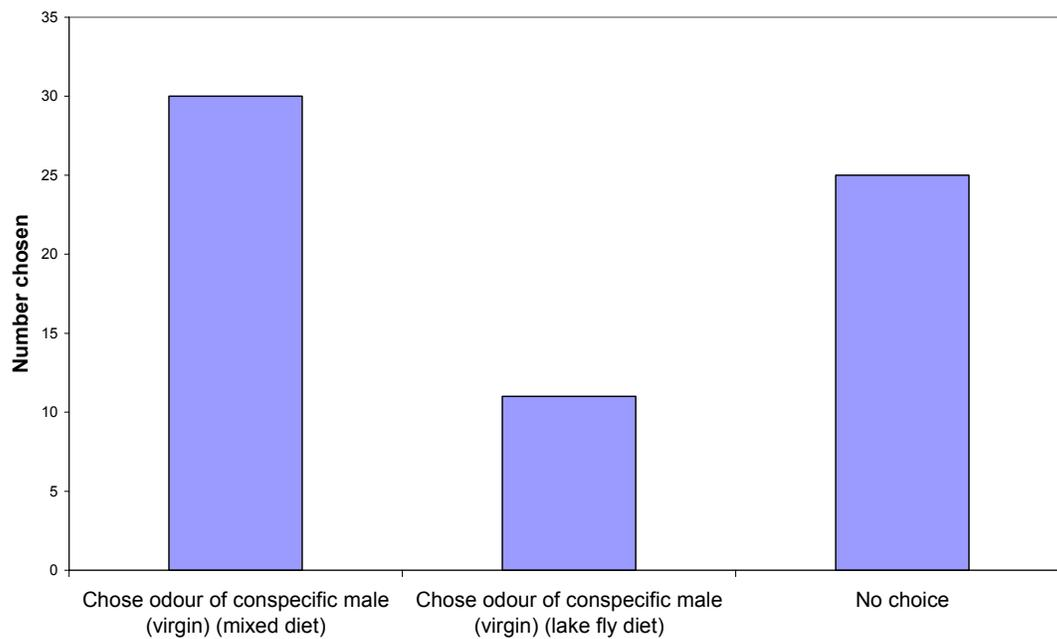

Figure 4.21. Results from testing *Evarcha culicivora* females in olfactometer showing odour of *E. culicivora* males maintained on mixed diet was chosen significantly more often than odour of *E. culicivora* males maintained on lake fly diet.

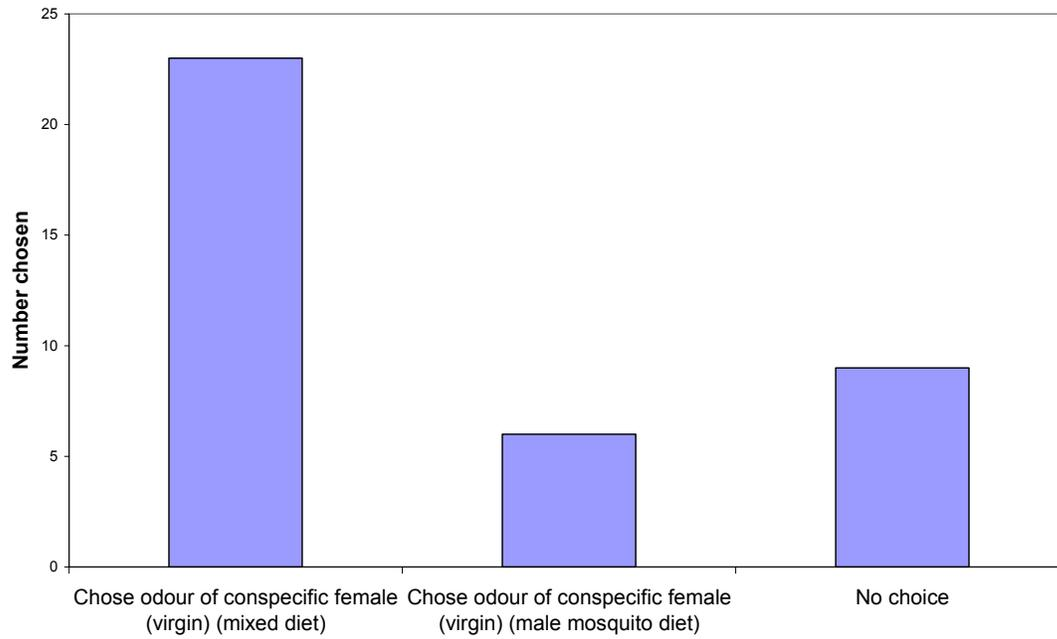

Figure 4.22. Results from testing *Evarcha culicivora* males in olfactometer showing odour of *E. culicivora* females maintained on mixed diet was chosen significantly more often than odour of *E. culicivora* females maintained on *A. gambiae* male diet.

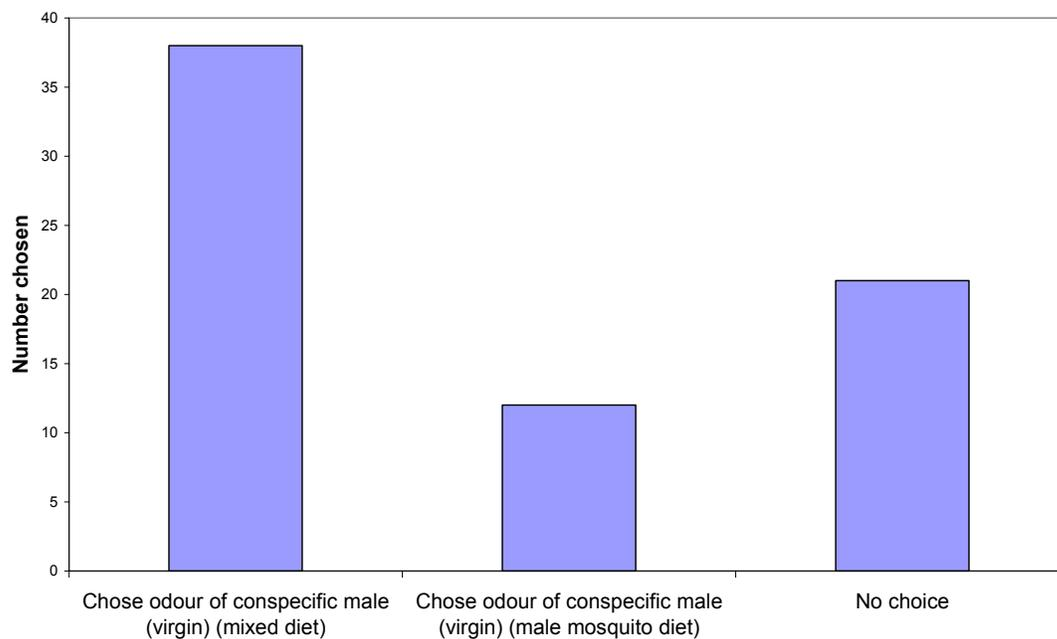

Figure 4.23. Results from testing *Evarcha culicivora* females in olfactometer showing odour of *E. culicivora* males maintained on mixed diet was chosen significantly more often than odour of *E. culicivora* males maintained on *A. gambiae* male diet.

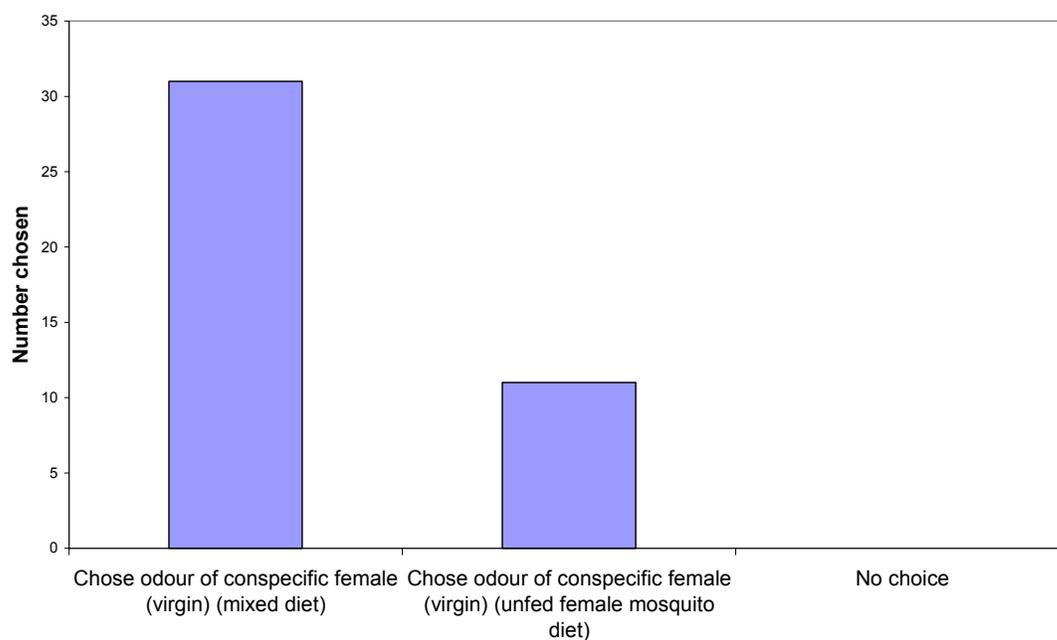

Figure 4.24. Results from testing *Evarcha culicivora* males in olfactometer showing odour of *E. culicivora* females maintained on mixed diet was chosen significantly more often than odour of *E. culicivora* females maintained on unfed *A. gambiae* female diet.

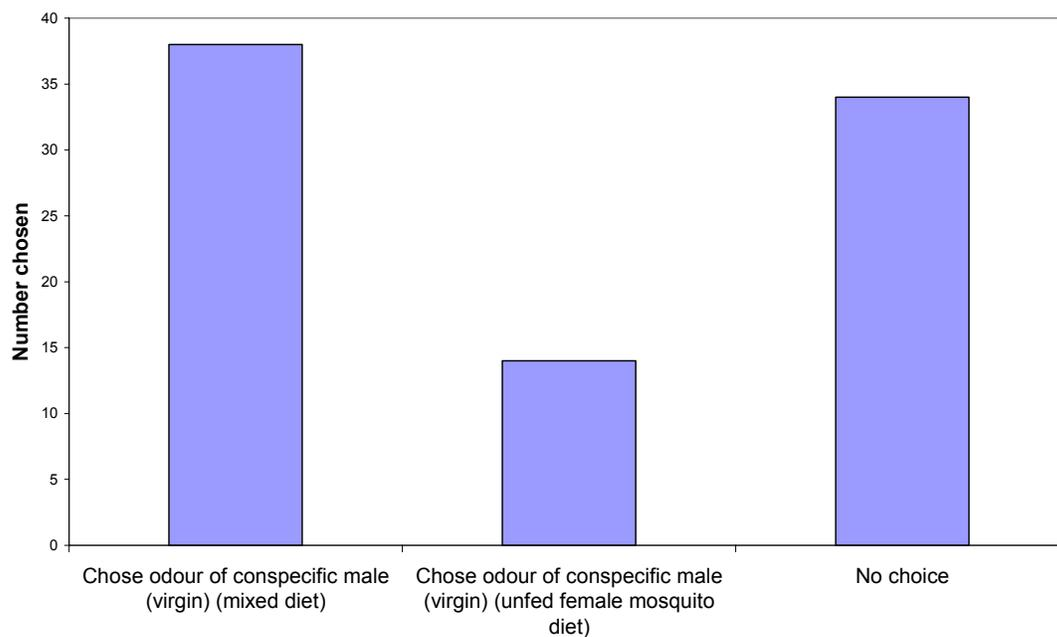

Figure 4.25. Results from testing *Evarcha culicivora* females in olfactometer showing odour of *E. culicivora* males maintained on mixed diet was chosen significantly more often than odour of *E. culicivora* males maintained on unfed *A. gambiae* female diet.

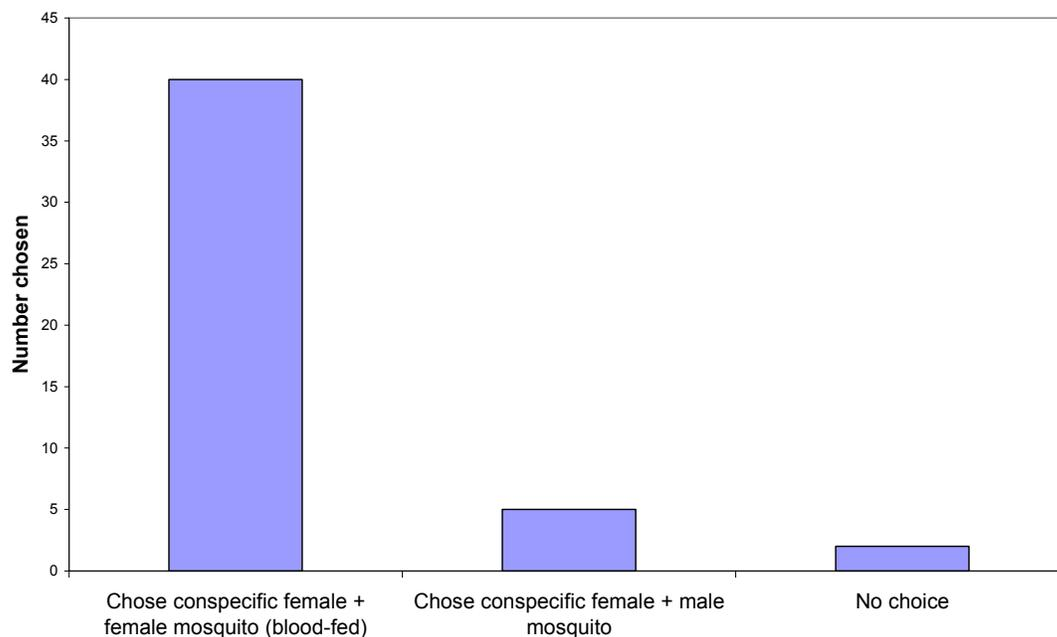

Figure 4.26. Results from testing *Evarcha culicivora* males in olfactometer showing odour of *E. culicivora* females maintained on *A. gambiae* male diet + odour of blood-fed *A. gambiae* females was chosen significantly more often than odour of *E. culicivora* females maintained on *A. gambiae* male diet + odour of *A. gambiae* males.

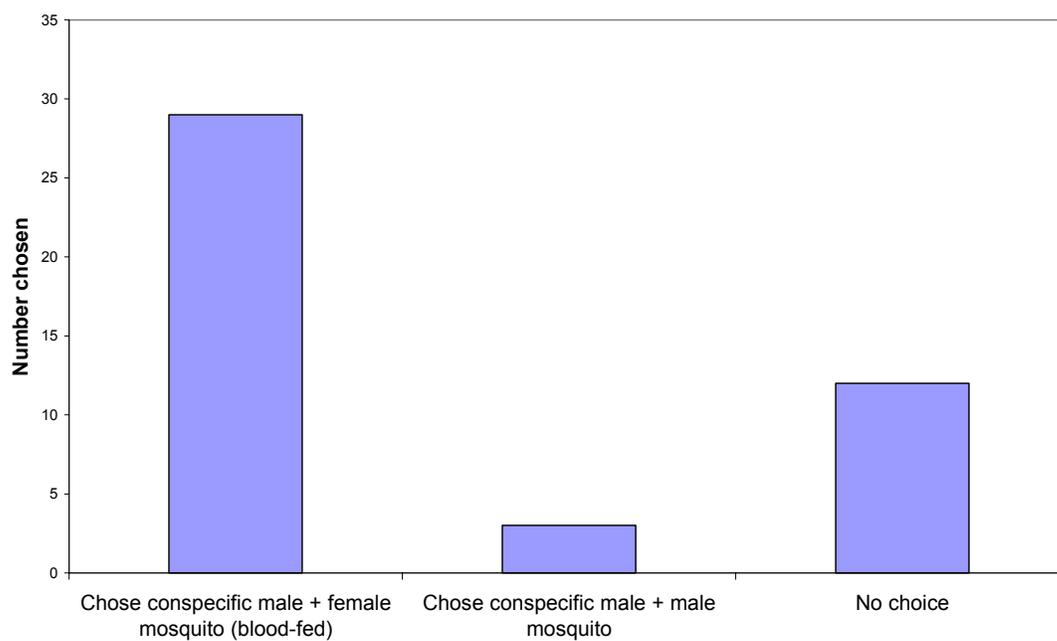

Figure 4.27. Results from testing *Evarcha culicivora* females in olfactometer showing odour of *E. culicivora* males maintained on *A. gambiae* male diet + odour of blood-fed *A. gambiae* females was chosen significantly more often than odour of *E. culicivora* males maintained on *A. gambiae* male diet + odour of *A. gambiae* males.

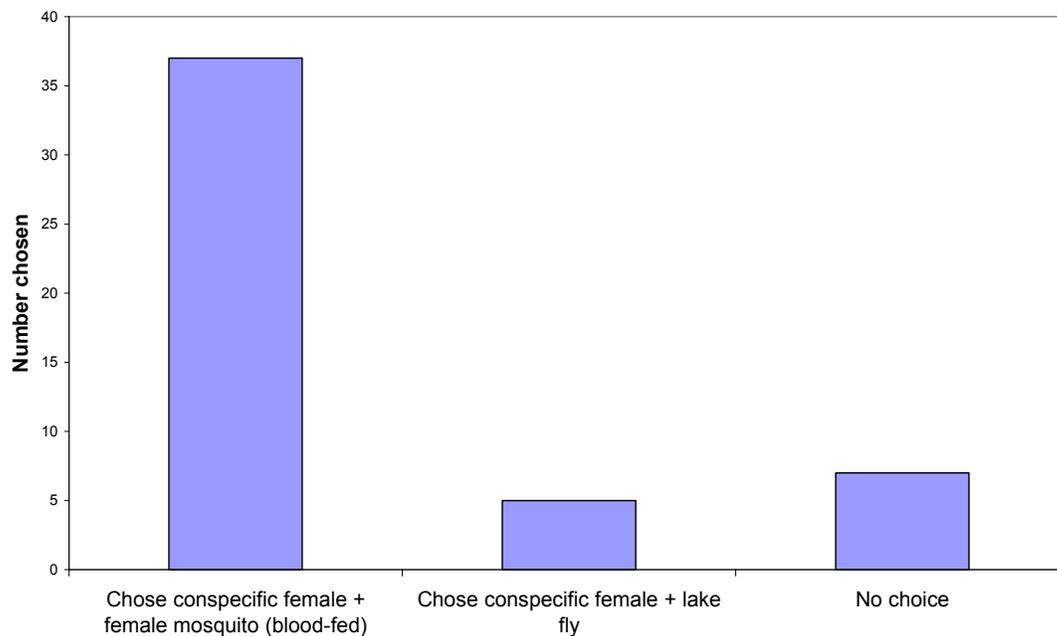

Figure 4.28. Results from testing *Evarcha culicivora* males in olfactometer showing odour of *E. culicivora* females maintained on lake fly diet + odour of blood-fed *A. gambiae* females was chosen significantly more often than odour of *E. culicivora* females maintained on lake fly diet + odour of lake flies.

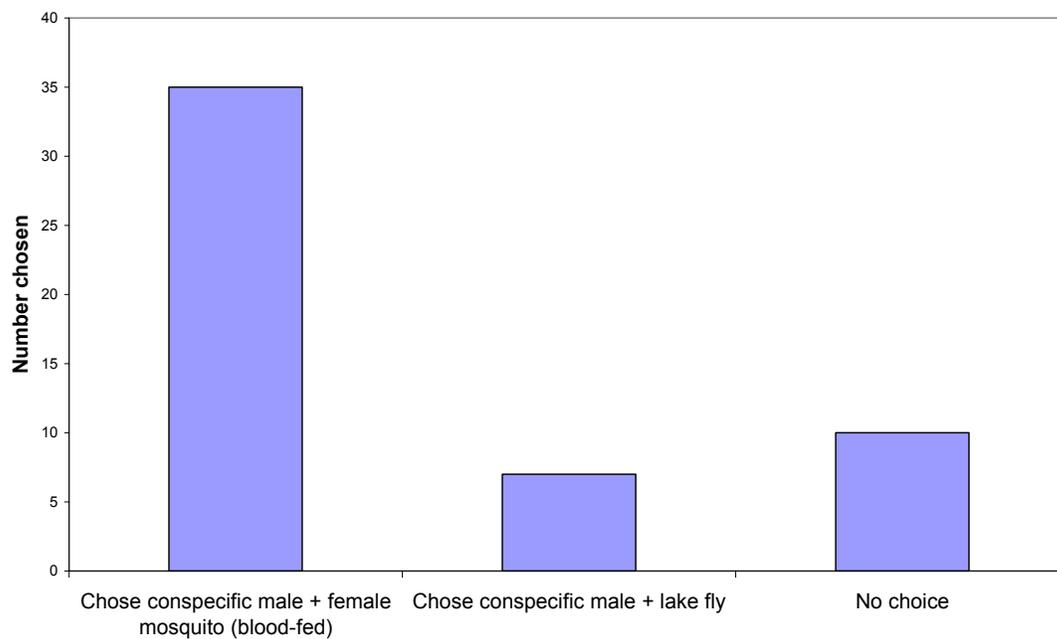

Figure 4.29. Results from testing *Evarcha culicivora* females in olfactometer showing odour of *E. culicivora* males maintained on lake fly diet + odour of blood-fed *A. gambiae* females was chosen significantly more often than odour of *E. culicivora* males maintained on lake fly diet + odour of lake flies.

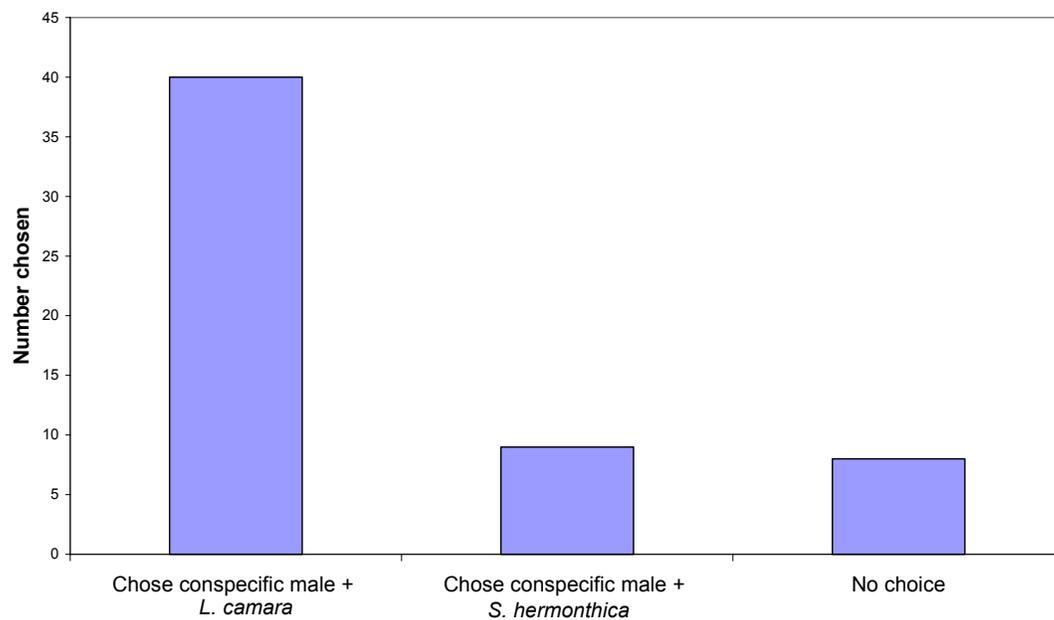

Figure 4.30. Results from testing *Evarcha culicivora* females in olfactometer showing odour of *E. culicivora* males maintained on *A. gambiae* male diet + odour of *L. camara* flowers was chosen

significantly more often than odour of *E. culicivora* males maintained on *A. gambiae* male diet + odour of *S. hermonthica* flowers.

CHAPTER 5

CROSS-MODALITY PRIMING EFFECTS OF CONSPECIFIC, PREY AND PLANT ODOUR ON THE MATE-CHOICE BEHAVIOUR OF *EVARCHA CULICIVORA*, A MOSQUITO-EATING JUMPING SPIDER (ARANEAE: SALTICIDAE)

As a step toward developing an animal model for studying cross-modality priming effects on visual selective attention, the influence of odours on the responses of *Evarcha culicivora* females to visual cues from *E. culicivora* males (potential mates) was investigated in three experiments during which the test spider had to find which one of four vials allowed it to approach mounts made from opposite-sex conspecific individuals. Non-standard methods were used for potentially making the target (conspecific mate) difficult to find, with these methods being derived from *E. culicivora*'s unique biology. (1) The other three vials gave *E. culicivora* access to its preferred prey, blood-fed female mosquitoes. (2) The potential mate was an extremely small ('midget'; body length 3 mm) conspecific individual used (test spider's body length 6 mm), and it is known that *E. culicivora* prefers larger mates. In Experiment 1, *E. culicivora* females responded to *E. culicivora* males significantly more often when in the presence of *E. culicivora* male odour than *E. culicivora* female odour, suggesting that male odour primed selective attention to optical stimuli from males. In Experiment 2, *E. culicivora* females responded to *E. culicivora* males significantly more often when in the presence of blood-fed female mosquito odour than male mosquito odour. In Experiment 3, *E. culicivora* females responded more to *E. culicivora* males significantly more often when in the presence of *Lantana camara* flower odour than *Striga hermonthica* flower odour. The relevance of cross-modality priming to understanding *E. culicivora*'s mate-choice behaviour is discussed.

Although the importance of attentional priming is well established in human cognitive psychology (Pashler, 1998; Palmer, 1999), the importance of attentional priming in other

animals is less clear. Attentional priming occurs when exposure to some particular stimulus causes an expectation of encountering some other particular stimulus (Anderson, 2000), the idea being that information from the priming stimulus enables the subject to attend selectively to some other particular stimulus to a greater extent than would be the case without this prior information. For example, human subjects respond faster when pairs of words presented simultaneously are related to each other (e.g. “bread” and “butter”) rather than unrelated (e.g. “nurse” and “butter”) (Meyer & Schvaneveldt, 1971). For humans, even bilingual priming effects are important (Neumann et al., 1999), and priming effects also apply to human face recognition (Faulkner et al., 2002) and music recognition (Tillmann et al., 2003), to name only a few examples.

Understandably, there has been a strong emphasis on distinctively human capacities (e.g., verbal language) in the literature on human priming effects. When using non-human animals for research on attentional priming, one of the challenges is to design experiments that are appropriate for the capacities of the species being studied. The typical approach has been to use food-related stimuli and record response times. For example, in pigeons (*Columba livia*), prior information from a particular visual stimulus can shorten response time to another related visual stimulus (e.g. Blough, 1989), where the response is the initial stage of feeding (Blough & Blough, 1997).

In research on non-human animals, as in human research, the emphasis in priming studies has been on how information from one stimulus induces selective attention to another stimulus in the same sensory modality. The sensory modality considered has most often been vision, with hearing (auditory stimuli) also being common and olfaction being especially rare. Compared with single-modality priming, much less is known about

cross-modality priming (i.e., information from a stimulus in one sensory modality making the individual selectively attentive to a particular stimulus in a different sensory modality) (Pauli et al., 1999). Although animal studies have shown the widespread importance of multi-modal communication (Harley et al., 1996; Guo & Gotz, 1997; Uetz, 2000; Johnen et al., 2001; Shine & Mason, 2001), the literature on animal multi-modal communication has rarely been concerned with experimentally demonstrating cross-modality priming in particular. Here I will investigate experimentally the relevance of cross-modality priming in the mate-choice behaviour of a jumping spider (Salticidae), *Evarcha culicivora*. The computational ability required for cross-modality priming appears to be achievable by a small salticid brain, as illustrated by a recent experimental study concerned with the predatory behaviour of *Portia fimbriata*, a salticid that preys by preference on other spiders (Jackson et al., 2002). *Jacksonoides queenslandicus*, another salticid from the same habitat as *P. fimbriata*, is frequently preyed on by *P. fimbriata*. Contact chemical cues from silk draglines left by *J. queenslandicus* on the substrate while walking about, and olfactory cues (*J. queenslandicus*' odour), both function for *P. fimbriata* as priming cues that make *P. fimbriata* selectively attentive to optical cues from specifically *J. queenslandicus*. That is, the smell or 'taste' (contact with draglines) of *J. queenslandicus* prepares *P. fimbriata* to see specifically *J. queenslandicus*.

The present study on *E. culicivora* differs from the study on *P. fimbriata* not only by considering priming in the context of mate-choice instead of prey-choice, but also because I consider priming cues that come from sources other than the source of the optical cues.

Previously, I showed that *E. culicivora*'s mate-choice behaviour is influenced by visual cues and by olfactory cues (Chapters 3 and 4). The hypotheses I test are that *E. culicivora* is primed to selectively attend to visual cues from potential mates when the odour of potential mates is also present, when the odour of blood-fed female mosquitoes is present or when the odour of *Lantana camara* flowers is present. Although the rationale for the first hypothesis might be obvious, the rationale for the other two hypotheses is less straightforward. *E. culicivora* has an unusual prey preference, blood-fed female mosquitoes, and an unusual and poorly understood affinity for certain plants, including *L. camara*. *E. culicivora* is attracted to the odour of its preferred prey and to the odour of *L. camara* (Chapter 4). These odours also enhance *E. culicivora*'s response to the odour of opposite-sex conspecific individuals, suggesting that there are some poorly understood links between the functional significance of particular prey and particular plants to *E. culicivora*'s mating biology. Here I take investigating these links a step further by considering cross-modality priming, where the olfactory priming stimulus sometimes comes from a source (prey or plant) different from the source of the optical cues. For this, I use the term 'cross-context priming.'

Materials and Methods

The apparatus was the same as for the size-preferences study (Chapter 3), except for an additional hole (8 mm diameter) in the centre of the bottom of the box (Fig. 5.1). There was a 30-mm long plastic tube connecting this hole to a petri dish and there was an odour source in the petri dish. In Experiment 1, live *E. culicivora* males ($n = 10$) or *E. culicivora* females ($n = 10$) were used as the odour sources (body length, 6 mm)

(maintained on mixed diet). Each of these spiders were individually placed inside plastic tubing (20 mm long, diameter 10 mm), with mosquito screening over each end of the tubing (held in place by small rubber bands). The spiders were spaced evenly around the sides of the petri dish, and were oriented perpendicularly with the edge of the dish (5mm from dish edge). In Experiment 2, live *Anopheles gambiae* females that had recently fed on blood ($n = 10$) or *A. gambiae* males ($n = 10$) were used as the odour sources. In Experiment 3, *L. camara* flowers or *Striga hermonthica* flowers were used as the odour sources, and these flowers filled the petri dish.

In all three of these experiments, mounts were positioned around the vials as in Chapter 3. However, here the mounts on one side of the box were always midget *E. culicivora* males (body length 3 mm). The rationale for using midget males was that, in the absence of odour, midget *E. culicivora* males are less attractive than large ('giant') males to *E. culicivora* females (see Chapter 3). On the other three sides of the box were mounts made from blood-fed *A. gambiae* females (termed as 'distractors' following the convention of other research in visual attention; Palmer, 1999). The rationale for using blood-fed female mosquitoes as distractors was that, as preferred prey, these provided stimuli that were salient to the test spider, but in a context different from mate detection.

The spiders tested were all virgin *E. culicivora* females of median size (6 mm in body length) that had been maintained on a mixed diet (lake flies plus blood-fed *A. gambiae* females). All spiders were tested only once (Experiment 1: with *E. culicivora* male odour, $n = 28$; with *E. culicivora* female odour, $n = 24$) (Experiment 2: with blood-fed *A. gambiae* female odour, $n = 32$; with *A. gambiae* male odour, $n = 27$) (Experiment 3: with *L. camara* odour, $n = 35$; with *S. hermonthica* odour, $n = 33$). When the spider

was tested, it was introduced through the hole at the top of the box and given 30 min to respond. The criterion for recording a ‘response to a conspecific male’ was when the test spider stayed for 30 s in the vial next to two *E. culicivora* male mounts and the criterion for ‘response to prey’ was when the test spider stayed for 30 s in one of the three vials next to mosquito mounts. The objective when testing was to ascertain whether *E. culicivora* females responded to conspecific males instead of prey. For data analysis, individuals that failed to respond at all (rare) were ignored, leaving the relevant test outcome a yes-no answer for each test: did the *E. culicivora* female respond to the conspecific male. Data from tests with different odours present were compared using chi-square tests of independence (see Howell, 2002).

Results

Influence of odour from conspecific individuals on response to optical cues from potential mates

E. culicivora females responded to mounts made from *E. culicivora* males significantly more often when in the presence of *E. culicivora* male odour than when in the presence of *E. culicivora* female odour ($\chi^2 = 6.38, p = 0.0116$; Fig. 5.2).

Influence of odour from prey on response to optical cues from potential mates

E. culicivora females responded to mounts made from *E. culicivora* males significantly more often when in the presence of blood-fed *A. gambiae* female odour than when in the presence of *A. gambiae* male odour ($\chi^2 = 9.72, p = 0.0018$; Fig. 5.3).

Influence of odour from plants on response to optical cues from potential mates

E. culicivora females responded to mounts made from *E. culicivora* males significantly more often when in the presence of *L. camara* odour than when in the presence of *S. hermonthica* odour ($\chi^2 = 7.53, p = 0.0061$; Fig. 5.4).

Discussion

The most straightforward results appear to be from Experiment 1. *E. culicivora* females more often responded to mounts made from *E. culicivora* males when in the presence of *E. culicivora* male odour rather than *E. culicivora* female odour. The odour of conspecific males appears to prime selective attention by *E. culicivora* to optical cues from conspecific males (i.e., odour seems to make *E. culicivora* expect to see a potential mate). As evidence of cross-modality priming in the context of mate-choice, these findings are comparable to the earlier findings from *P. fimbriata* showing cross-modality priming in the context of prey-choice (Jackson et al., 2002).

Interpreting the results of Experiments 2 and 3, however, is less straightforward. In Experiment 2, *E. culicivora* females responded more often to *E. culicivora* male mounts when the odour present was from blood-fed *A. gambiae* females, rather than odour from *A. gambiae* males. Interpreting this result is not straightforward. Blood-fed female mosquitoes are *E. culicivora*'s preferred prey, and there were mounts made from blood-fed female mosquitoes next to three of the four vials. *P. fimbriata*, in the presence of prey odour, responded more strongly to the optical stimuli from the prey (Jackson et al., 2002). A parallel finding here would have been for *E. culicivora* females to respond more strongly to

the visual cues from the prey when the odour of that prey was also present. This would have been what might be called a conventional example of cross-modality priming. Instead, *E. culicivora* responded to mounts of potential mates when the odour of blood-fed *A. gambiae* females (prey) was present. Unlike in Experiment 1, the priming odour and the visual cues came from different sources. This appears to be an example of cross-context priming. However, findings from earlier experiments (Chapter 4) suggested, that, for *E. culicivora*, mating and feeding strategies are interrelated, with the specific dietary odour gained from feeding on blood-fed female mosquitoes making individuals of this spider species more attractive to potential mates. Perhaps the different ‘contexts’ in this example of cross-context priming are not so different as they first appear to be. For this species, preferred prey odour is relevant to mating behaviour.

In Experiment 3, *E. culicivora* females responded more often to *E. culicivora* male mounts when in the presence of *L. camara* flower odour, rather than *S. hermonthica* flower odour. Again, this appears to be an example of both cross-modality and cross-context priming, and again the two ‘contexts’ may not actually be so different as they at first appear to be. *E. culicivora* feeds on nectar, and the odour of *L. camara* flowers can be envisaged as a dietary odour that primes *E. culicivora* for encounters with potential mates. However, for *E. culicivora*, *L. camara* may also be a plant species that serves as a meeting place for courtship and mating (Chapter 2). Odour from the *L. camara* flowers may prime individuals of *E. culicivora* for encounters with opposite-sex conspecifics (i.e., potential mates) to be encountered on the plant. There is also evidence that acquiring odour from *L. camara* may render individuals of *E. culicivora* more attractive as potential mates for

opposite-sex conspecific individuals (Chapter 4). For *E. culicivora*, odour from certain plants, along with odour from certain prey, appears to be relevant to mating behaviour.

It may be interesting to compare these findings for *E. culicivora* with the well-known *Stroop* effect from research in human visual attention. An example of the Stroop effect is how human subjects are typically much slower to say the word 'red' when the word is actually 'blue' (and printed in the colour red), rather than red (Schiffman, 1996). We might envisage, for *E. culicivora* females, entering a particular vial as 'saying' '*E. culicivora* male' or saying 'mosquito.' In the presence of the odours of blood-fed *A. gambiae* females, *E. culicivora* females appear to do the reverse of what we might expect from transferring Stroop-effect expectations to a spider. When smelling a mosquito, the *E. culicivora* female does not say 'mosquito.' Instead, the *E. culicivora* female says '*E. culicivora* male.'

References

- Anderson, J. R. (2000). *Cognitive psychology and its implications* (5th ed.). New York: Worth Publishers Inc.
- Blough, D. S., & Blough, P. M. (1997). Form perception and attention in pigeons. *Animal Learning and Behavior*, *25*(1), 1-20.
- Blough, P. M. (1989). Attentional priming and visual search in pigeons. *Journal of Experimental Psychology: Animal Behavior Processes*, *15*(4), 358-365.
- Endler, J. A., & Basolo, A. L. (1998). Sensory ecology, receiver biases and sexual selection. *Trends in Ecology & Evolution*, *13*(10), 415-420.
- Faulkner, T. F., Rhodes, G., Palermo, R., Pellicano, E., & Ferguson, D. (2002). Recognizing the un-real McCoy: Priming and the modularity of face recognition. *Psychonomic Bulletin & Review*, *9*(2), 327-334.
- Guo, A., & Gotz, K. G. (1997). Association of visual objects and olfactory cues in *Drosophila*. *Learning & Memory*, *4*(2), 192-204.
- Harley, H. E., Roitblat, H. L., & Nachtigall, P. E. (1996). Object representation in the bottlenose dolphin (*Tursiops truncatus*): integration of visual and echoic information. *Journal of Experimental Psychology: Animal Behavior Processes*, *22*(2), 164-174.
- Howell, D. C. (2002). *Statistical methods for psychology* (5th ed.). Belmont, California: Wadsworth.

- Jackson, R. R., Clark, R. J., & Harland, D. P. (2002). Behavioural and cognitive influences of kairomones on an araneophagic jumping spider. *Behaviour*, *139*, 749-775.
- Johnen, A., Wagner, H., & Gaese, B. H. (2001). Spatial attention modulates sound localization in barn owls. *Journal of Neurophysiology*, *85*(2), 1009-1012.
- Lunau, K. (1992). Evolutionary aspects of perfume collection in male euglossine bees (Hymenoptera) and of nest deception in bee-pollinated flowers. *Chemoecology*, *3*(2), 65-73.
- Meyer, D. E., & Schvaneveldt, R. W. (1971). Facilitation in recognizing pairs of words: Evidence of a dependence between retrieval operations. *Journal of Experimental Psychology*, *90*(2), 227-234.
- Neumann, E., McCloskey, M. S., & Felio, A. C. (1999). Cross-language positive priming disappears, negative priming does not: Evidence for two sources of selective inhibition. *Memory & Cognition*, *27*(6), 1051-1063.
- Palmer, S. E. (1999). *Vision science: photons to phenomenology*. Cambridge, Massachusetts: MIT Press.
- Pashler, H. E. (1998). *The psychology of attention*. Cambridge, Massachusetts: MIT Press.
- Pauli, P., Bourne, L. E., Jr., Diekmann, H., & Birbaumer, N. (1999). Cross-modality priming between odors and odor-congruent words. *American Journal of Psychology*, *112*(2), 175-186.
- Schiffman, H. R. (1996). *Sensation and perception: An integrated approach* (4th ed.). Oxford: John Wiley & Sons.

- Shine, R., & Mason, R. T. (2001). Courting male garter snakes (*Thamnophis sirtalis parietalis*) use multiple cues to identify potential mates. *Behavioral Ecology and Sociobiology*, 49(6), 465-473.
- Tillmann, B., Janata, P., & Bharucha, J. J. (2003). Activation of the inferior frontal cortex in musical priming. *Cognitive Brain Research*, 16(2), 145-161.
- Uetz, G. W. (2000). Signals and multi-modal signaling in spider communication. In Y. Espmark, T. Amundsen & G. Rosenqvist (Eds.), *Animal signals: signalling and signal design in animal communication* (pp. 387-405). Trondheim: Tapir Academic Press.

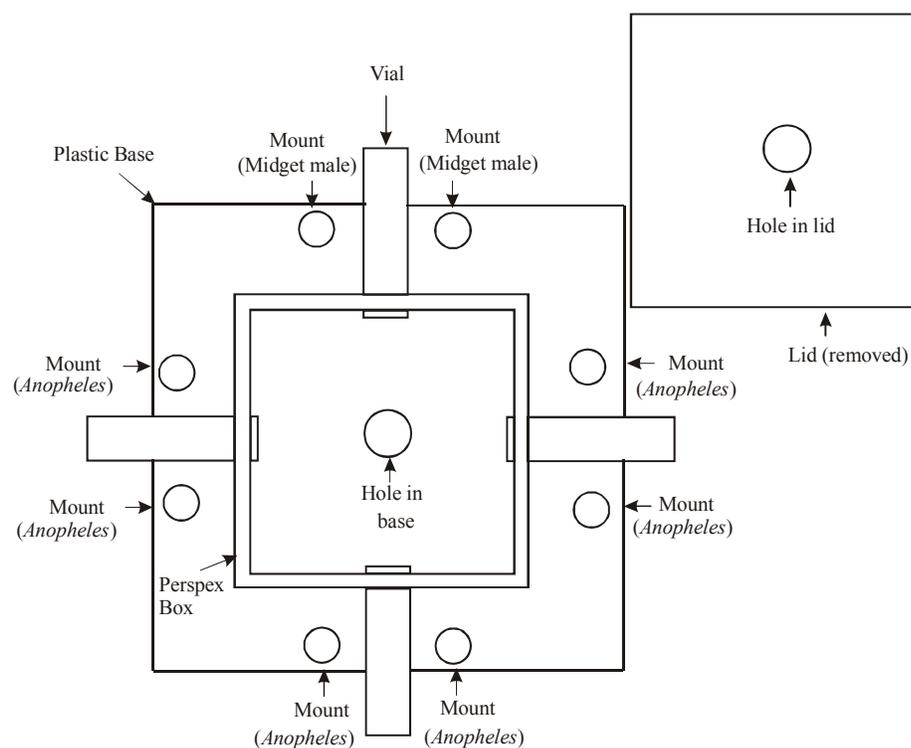

Figure 5.1. Mate-choice apparatus for Experiments 2 and 3 (not drawn to scale). Spider enters through hole in lid and has access to the four vials (vials open on inside of box, but closed on outside of box). There was one mount on each side of each vial. In Experiment 1, there were mounts of two midget *Evarcha culicivora* males outside one of the vials, while outside the other three vials were mounts of *E. culicivora* females. In Experiments 2 and 3, there were mounts of two midget *E. culicivora* males outside one of the vials, while outside the other three vials were mounts of blood-fed *A. gambiae* females (as in this figure). An odour source (from conspecifics, prey or flowers) came from a petri dish outside the perspex box. The odour came through a tube that connected through a hole at the bottom of the perspex box to a hole in the petri dish.

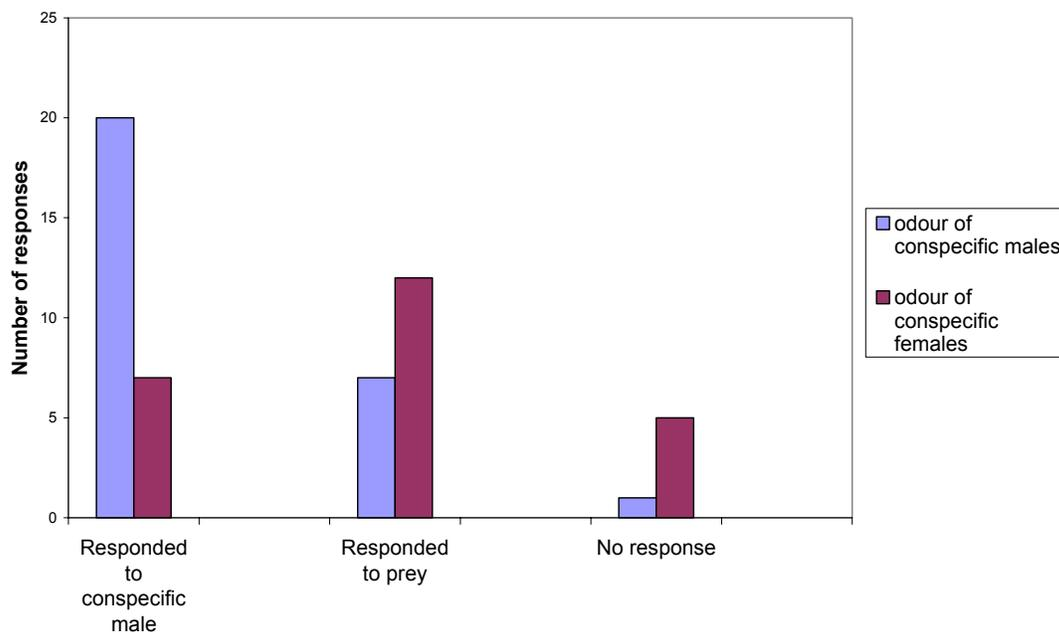

Figure 5.2. Outcome of mate-choice tests using *Evarcha culicivora* females. Responded to midget *E. culicivora* male mounts when in presence of odour of *E. culicivora* males significantly more often than when in presence of odour of *E. culicivora* females.

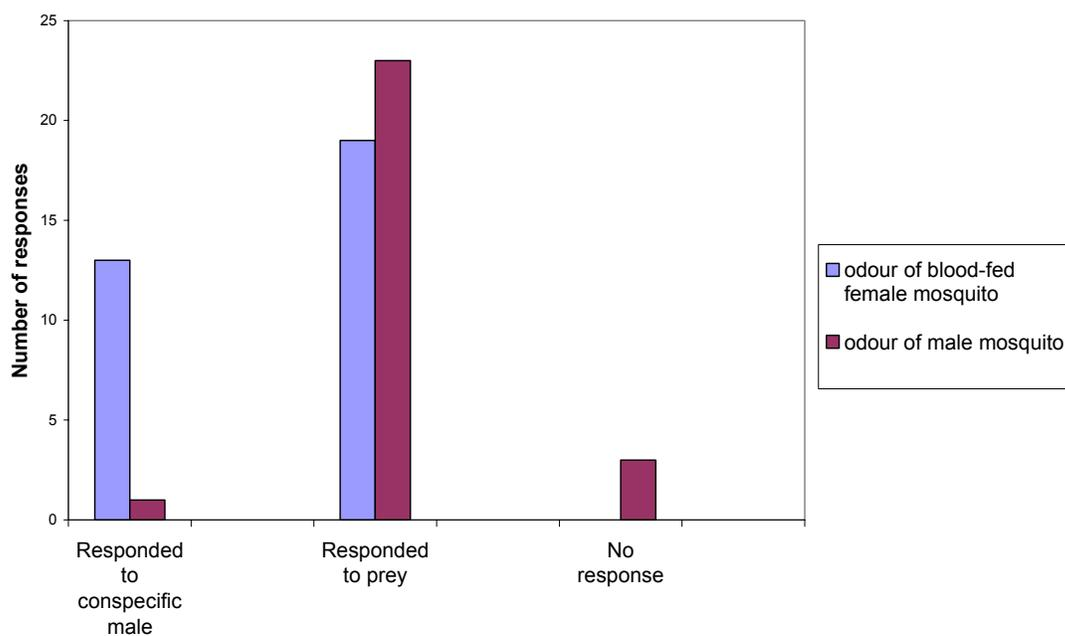

Figure 5.3. Outcome of mate-choice tests using *Evarcha culicivora* females. Responded to midge *E. culicivora* male mounts when in presence of odour of blood-fed *A. gambiae* females significantly more often than when in presence of odour of *A. gambiae* males.

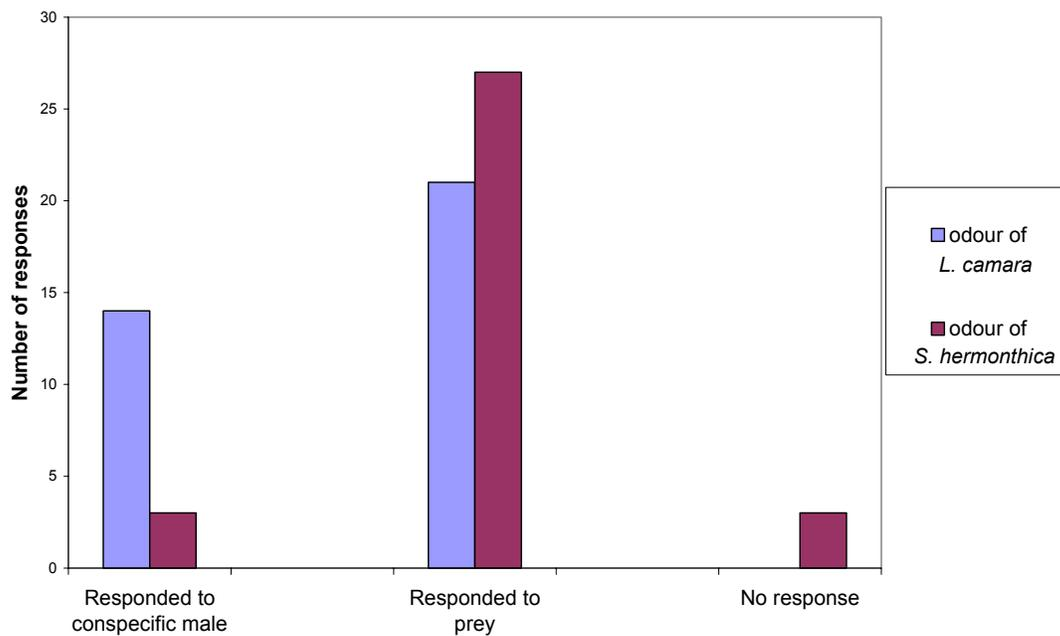

Figure 5.4. Outcome of mate-choice tests using *Evarcha culicivora* females. Responded to midge *E. culicivora* male mounts when in presence of odour of *L. camara* flowers significantly more often than when in presence of odour of *S. hermonthica* flowers.

CHAPTER 6

DISCUSSION

For research in cognitive psychology, humans are the conventional subjects (Pashler, 1998; Palmer, 1999; Anderson, 2000). Much less is known about animal cognition, but there appears to be a growing appreciation of how questions about cognition may enrich our understanding of animal behaviour (Shettleworth, 1998, 2001). The extent to which it is useful to define something as basic as ‘cognition’ is debatable, but the term tends to be associated with the notion of ‘minds.’ ‘Mind’ may be even more dubiously subject to definition, but Minsky’s (1986) way out of this impasse may suffice: “Minds are simply what brains do.” Another attempt at a simple working definition is to envisage cognition as ‘information processing’ (Shettleworth, 2001), with perhaps an underlying assumption that more central (‘mind level’) processing is more interesting to discuss as cognitive. From this sort of perspective, ‘cognition’ is not simply a thing that animals either have or not. For animals, the question becomes instead whether they carry out processing (what their brains do) that is elaborate enough to make questions related to cognition interesting when considering their behaviour.

From this perspective, brain size would appear to be important. Compared with a human, a spider, for instance, is a much smaller animal. By human standards, a spider’s brain is minute. Even in much larger animals, it is widely held that brain size limits cognitive ability (Lashley, 1949; Rensch, 1956; Maunsell, 1995). Salticids have brains small enough to fit on a pin head (Harland & Jackson, 2000), and the first question might

be whether their small brain size is large enough to make them useful subjects for research on animal cognition. Recent research on salticid predator behaviour (Jackson & Pollard, 1996; Jackson & Wilcox, 1998) suggests that these spiders are large enough for generating behaviour relevant to problem solving, representation and planning ahead, but perhaps small enough to make understanding underlying processes especially tractable.

In this thesis, my primary interest has been in using small animals to study processes underlying visual attention and especially cross-modality priming effects on visual attention. I chose a salticid spider (*Evarcha culicivora*) with unusual predatory behaviour. However, instead of studying predatory behaviour, I studied how individuals of this species interact with each other. The first step (Chapter 2) was to get baseline information needed for developing my subsequent chapters. This basic study revealed that the behaviour of *E. culicivora* during male-male, female-female and especially male-female interactions is exceptionally complex and variable even for a salticid, and it raised numerous questions of potential relevance to cognition.

Mate-choice experiments (Chapter 3) showed that *E. culicivora* females tend to choose larger males as potential mates more often than smaller males, and that *E. culicivora* males tend to choose larger females. *E. culicivora* appears to be a species for which mutual mate-choice is exceptionally pronounced. In these experiments, mate-choice decisions were made on the basis of vision alone.

Next (Chapter 4), I investigated how *E. culicivora* responds to odour alone. These odours came from opposite-sex conspecific individuals, from mosquito-derived blood and from particular plants (*Ricinus communis* and *Lantana camara*). All of these odours attracted *E. culicivora*. Prior feeding on mosquito-derived blood made the odour of *E.*

culicivora individuals even more attractive to opposite-sex individuals. Plant odour also appeared to enhance *E. culicivora*'s attractiveness to potential mates.

Cross-modality priming of visual attention was investigated experimentally in Chapter 5. Evidently, *E. culicivora* is primed by the odour of opposite-sex individuals to attend selectively to optical cues from potential mates. For *E. culicivora*, cross-context priming is also relevant. Odours of preferred prey (blood-fed female mosquitoes) or at least one of the preferred plants (*L. camara*) apparently primes *E. culicivora* to attend selectively to optical cues from opposite-sex conspecific individuals.

Selective attention, although traditionally an important topic in human cognitive psychology (Pashler, 1999), has rarely been considered in research on salticids. Whether selective attention might be relevant to salticids at all might appear questionable because, based on research on much larger animals, especially humans and other vertebrates (Rees et al., 1997; Desimone, 1998; Dukas & Kamil, 2000), it has been concluded that selective attention places heavy demands on computational resources. What these 'resources' might actually be, and how limiting they might be, is controversial (Pashler, 1998).

However, the salticid's brain power is apparently sufficient for making these animals interesting subjects for studying selective attention. Besides the experimental evidence (Chapter 5) that *E. culicivora* individuals selectively attended to optical cues of potential mates when in the presence of certain odours, my impression from the behavioural observations in Chapter 2 of *E. culicivora* individuals engaging in courtship displays is that the spiders were more attentive to each other than their surrounding environment. For example, once courtship began, they were not distracted when I took notes. Yet, before courtship began, my movement readily elevated turning responses

from the spiders. Perhaps selective attention tasks are especially demanding for *E. culicivora*. Although *E. culicivora*, despite its small brain size, evidently has the mental capabilities required for basic selective-attention tasks, small brain size nonetheless places interesting limitations on the sorts of tasks *E. culicivora* can perform. For example, much research has been done on human ability to perform divided attention-tasks (Pashler, 1998), and many examples of divided attention are familiar to us from outside the laboratory (e.g., carrying out a conversation while reading a newspaper). Perhaps small brain size severely limits *E. culicivora*'s capacity (relative to humans) for performing divided-attention tasks. Even in animals larger than *E. culicivora* (such as birds) divided attention appears to be highly limited (Dukas & Kamil, 2000, 2001).

In Chapter 5, the evidence of cross-modality and cross-context priming effects on visual attention suggests that *E. culicivora* may be predisposed to direct selective attention in ways that are, to us, initially surprising. With its unusual diet, and with its unprecedented and poorly understood affinity for particular plant species, *E. culicivora* has what appears to be the most complex natural history ever described for a spider. My impression is that this complex natural history spills over into an unusual and complex cognitive profile. Perhaps part of what this means is that *E. culicivora* compensates for limited capacity for divided attention by using specialised selective attention skills and relying on specialised roles for priming.

Some of the findings from Chapter 5 may be interesting in relation to the Stroop effect, which is a well-studied topic in human visual-attention studies (Anderson, 2000). The Stroop effect is seen, for instance, when people are shown a list of the names of different colours with these names printed in different colours of ink. A test subject is

instructed to read the list aloud. People are much slower, and make many more mistakes, when they try, for example, to say “red” when the word “yellow” is printed in red ink. The word “red” printed in red ink is said faster and with fewer errors. An interpretation of these findings is that, when the text and ink colour do not match, there is cognitive interference of the person’s ability to read the name of the colour (Schiffman, 1996). The experiments in Chapter 5 are certainly not directly comparable to experiments in human cognitive psychology designed for investigating the Stroop effect. Nor was investigating a spider equivalent of the Stroop effect my goal. The goal was instead to ascertain whether various odours influenced how readily *E. culicivora* used optical cues to find a potential mate. There were four vials the test spider could enter, only one of which brought it closer to a potential mate. The other three vials were aligned with optical cues from a distractor. The distractor was *E. culicivora*’s preferred prey.

The most straightforward experiment examined whether odour from a potential mate enhanced how readily *E. culicivora* used optical cues to get close to a potential mate. This might be envisaged as somewhat like the word “red” being written in red during a Stroop-effect experiment on human subjects. In another experiment, *E. culicivora* was exposed to plant odours and seen to respond more readily to optical cues from a potential mate when the plant odour came from *Lantana* instead of a control plant (*Striga*). Here the odour source (plant) did not match either source of optical cues (potential mate or potential prey). This is a surprising finding, which I called cross-context priming.

When compared with the Stroop effect, the most surprising evidence of cross-context priming came from the experiment in which prey odour (from blood-fed female

mosquitoes) was used as the primer. In the presence of preferred prey odour, with optical cues from preferred prey serving as distractors, *E. culicivora* more readily moved into the vial that brought it closer to a potential mate than when in the presence of non-preferred prey. This might be envisaged as somewhat like the word “yellow” being written in red during a Stroop-effect experiment and finding that seeing “yellow” written in red enhanced performance (i.e., it made a person more inclined to say “red” than would have been the case had the word “yellow” been some other word (e.g., blue, rather than yellow)). Findings from Stroop-effect experiments with humans suggest that perceiving two cues that do not match interferes with performance of the required task (seeing the colour red seems to make a person expect to see the word “red”). In Chapter 5, something like the opposite effect was suggested for *E. culicivora* (smelling preferred prey seemed to make *E. culicivora* expect to see a potential mate and overlook potential prey). Potential hints for how to explain these surprising findings might be seen in the findings from Chapter 4 which suggested that certain dietary odours make *E. culicivora* more attractive as potential mates. The findings from Chapter 5 seem to take the conclusion from Chapter 4 a step further by suggesting that these dietary odours may cause *E. culicivora* to attend selectively to the optical cues from potential mates.

The research in this thesis is unusual not only because of considered visual attention in an unusual test subject. It is also unusual because of the context in which visual attention is considered. In animals in general, visual attention has not been widely studied in the domain of courtship and mate-choice behaviour (Dukas, 2002), although a number of earlier studies concerned with other types of animals have unwittingly suggested the importance of visual attention when animals choose their mates. For

example, many studies (Andersson, 1982; Noonan, 1983; Swaddle & Cuthill, 1994; Kodric-Brown & Johnson, 2002) discuss the role of female ‘choosiness’ in mate-choice behaviour, but without explicitly acknowledging that being ‘choosy’ requires that females of the species in question have the specific cognitive capabilities implied by the notion of females looking at the conspecific males in their vicinity and deciding which ones to have as mates (i.e., that the animal attends to the potential mates, compares some particular cues that reveal the quality of these potential mates, and then makes a decision to accept one as a mate).

The literature on sexual selection in general, and the literature on sexual selection in spiders in particular, has had an interesting history related to animal cognition. In the early literature, much of the opposition to Darwin’s sexual selection theory was based on a misconstrual of the type of “selection” being proposed. For example, Peckham and Peckham (1889, 1890) argued that sexual selection has shaped the evolution of salticid courtship, whereas Montgomery (1908, 1909) was apparently incompatible with the notion that a spider has the cognitive ability of choosing and having preferences. Later literature made emphatic how sexual selection is a particular category of natural selection (Trivers, 1972) and “selection” in this context refers to an evolutionary algorithm (Dennett, 1996) (i.e., it is “mindless,” not cognitive). “Sexual selection” does not refer to an individual animal’s behaviour of choosing a mate. There is a different term for this, “mate choice.” What may be too easily overlooked is that “mate choice” (Andersson, 1994), as opposed to sexual selection, does invite questions about cognition. It may invite questions about selective attention in particular.

THE RELATIONSHIP BETWEEN VISUAL ATTENTION AND MATE-CHOICE BEHAVIOUR

Cognition can be envisaged as including perception, learning, memory and decision making (Shettleworth, 2001). Attention, however, appears to be an especially basic facet of cognition. For example, cognitive tasks involving making decisions about something (such as what mate to choose) seem to presuppose attention to the potential choices.

Dukas (2002) in particular has suggested recently that behavioural-ecology research on mate-choice behaviour might be enriched by considering the role of attention. For example, in some courtship settings, a female might be initially involved in some other task, such as foraging, when a male arrives. To attract the female's attention, the male may need to alert the female to his presence (i.e., get her attention). Perhaps he can do this by making abrupt movements, where the stimuli from this type of movement have salience for the female because normally they are associated, for example, with a predator rapidly closing in for an attack (i.e., when the female perceives this type of movement, she may be highly predisposed to direct her eyes toward the source). Upon directing her gaze, the female can perceive that the source is a potential mate, not a predator. Next the female has to decide whether to attend more closely to the male or not. Dukas (2002) suggested that males engage in continuous movement in their courtship displays to sustain the female's attention. Much the same argument has been suggested before as being relevant to salticid courtship in particular (Jackson & Pollard, 1997). Much of what Dukas (2002) argued is also implicit in what Guilford and Dawkins (1991) called receiver psychology.

E. culicivora engages in elaborate courtship displays that are rich in movement, and individuals of *E. culicivora* include a wide range of different behaviour categories in courtship sequences, combining these in many different ways, thereby generating courtship that appears to be more elaborate and variable than that ever described for any other salticid studied to date.

Displays especially rich in movement may give *E. culicivora* an especially effective means to attract the attention of potential mates, seemingly more so than for other salticids, but the reason why *E. culicivora*'s courtship has become so extreme is not immediately obvious. Display that is complex enough to attract the attention of potential mates would appear to be advantageous to more or less all salticids. However, *E. culicivora* has an unusual diet and an affinity with certain plants, and it might be useful to explore how prey and plant specialisation has influenced display complexity.

E. culicivora's specialised diet may be difficult to satisfy. Cognitively, it may be especially demanding. *E. culicivora* may need to heavily commit limited computational resources when selectively attending to mosquitoes. Unless trained, most people have considerable difficulty distinguishing between mosquitoes and 'midges' (lake flies) or between male and female mosquitoes. Despite using eyes and a brain much smaller than ours, *E. culicivora* makes these discriminations. However, achieving this may come with a cost. Discriminating between preferred and non-preferred prey may place cognitive demands on *E. culicivora* that are exceptional for a salticid. Indirectly, these cognitive demands may influence *E. culicivora*'s courtship complexity. Our current understanding of this unusual species may make formulating specific hypotheses premature, but two might be mentioned primarily as examples. When one *E. culicivora* individual encounters

an opposite-sex conspecific individual that is engaged in hunting behaviour, the task of attracting the attention of a hunter may be more demanding than it would be for other salticids (*E. culicivora* may need to use a lot of movement to direct the other spider's attention away from the potential prey and to get it to focus its attention instead on the potential mate). This hypothesis might be a start, but it does not readily account for display complexity after attracting the other spider's attention.

A different kind of hypothesis is to consider something like truth in advertising. Perhaps it is particularly important for *E. culicivora* to choose as potential mates individuals that have particular cognitive abilities that are reliably indicated by the potential mate's ability to orchestrate a complex courtship sequence. An important factor here is how the interacting individuals tend to move about. Each has to maintain attention on a moving target while at the same time organising a great variety of different behaviour patterns. Skill at courtship under these circumstances may overlap with the skill needed for preying on a specifically difficult to detect prey in the presence of numerous other similar, but not preferred prey. If these skills are heritable, requiring *E. culicivora*'s complex, variable style of courtship might be advantageous for the choosing individual. Having a low threshold for habituating to repetition of display patterns (see Jackson, 1982) is a straightforward potential mechanism for achieving preference for variety.

The second hypothesis may be relevant to *E. culicivora*'s inclination to mate on *Lantana* flowers (Chapter 2). The dense flower clusters of these plants create visual obstructions which must make it harder for the spiders to see each other when they interact. During courtship, perhaps *E. culicivora* need to use highly variable and complex

displays to keep the other individual's attention in the presence of these visual obstructions. Or, as a different spin on this hypothesis, perhaps being predisposed to meet on *Lantana* flowers is advantageous because it forces the other individual into a challenging situation that tests its ability to orchestrate complex display behaviour.

SENSORY EXPLOITATION

Selective attention may have particular relevance for understanding sensory exploitation. Sensory exploitation is a recent perspective on explaining mate-choice behaviour (Endler & Basolo, 1998). Although often envisaged as an alternative to more traditional theory used to explain the evolution of mate-choice behaviour (runaway selection and the handicap principle), all three might be more usefully be viewed as complementary.

Communication can be envisaged as taking place between two individuals, a sender and a receiver. The sender makes a signal (a stimulus) to which the receiver responds. The basic idea behind sensory exploitation (Endler, 1992; Endler & Basolo, 1998) is that the sender uses as signals stimuli that already have salience for the receiver. The idea is that the receiver has a predisposition to respond to this stimulus in some particular way that is advantageous to the sender. For example, the water mite *Neumania papillator* is a predator of *Daphnia*. Prey detection is based on perceiving the distinctive underwater pressure waves *Daphnia* makes while swimming. The water mite is attracted to this stimulus and when close, grabs hold of the *Daphnia*. Water mite males court by trembling their legs to make signals that mimic the stimulus made by *Daphnia*. The female water mite detects this stimulus, and grabs hold of the male. In this way, the male

gets the female's attention. His courtship trembling exploits a predisposition of the female to respond to particular underwater pressure wave patterns, where this predisposition (the salience of the stimulus) evolved in a different context (i.e., prey choice, not mate choice) (Proctor, 1992).

Sensory exploitation in *E. culicivora* is suggested especially by how prey and plant odour seem to be integrated into courtship and mate choice. In *E. culicivora*'s case, preferences for certain dietary odours (from blood-fed female mosquitoes and from *L. camara*) presumably evolved in the context of feeding, but have been co-opted by opposite-sex conspecifics to amplify their attractiveness as potential mates.

CONCLUSIONS

Although the emphasis in the literature on animal mate-choice behaviour has been on questions in the context of evolution, adaptive significance, ultimate causation and especially sexual selection, this literature often unwittingly refers to cognition. For example, interesting cognitive ability may often be pre-supposed by theory where the primary interest is in the adaptive advantage of being 'choosy' and not in the mechanisms by which choice is achieved.

Sensory exploitation represents a shift in the literature on animal mate-choice, with questions concerning animal cognition coming more into the foreground. Sensory exploitation and receiver psychology appear to be especially promising perspectives from which to understand the behaviour of *E. culicivora* during interactions between conspecific individuals. Understanding processes underlying selective attention may be especially relevant for understanding the mate-choice behaviour of *E. culicivora*.

Considering *E. culicivora*'s behaviour from the perspective of sensory exploitation and receiver psychology may clarify proximate (mechanisms) with ultimate (adaptive significance) explanations of mate-choice behaviour.

Salticidae is a family of spiders known for garish display of colour. *E. culicivora* may look commonplace, if not dull, in comparison. However, *E. culicivora* is living proof that a salticid book should not be judged by its cover.

REFERENCES

- Anderson, J. R. (2000). *Cognitive psychology and its implications* (5th ed.). New York: Worth Publishers Inc.
- Andersson, M. (1982). Female choice selects for extreme tail length in a widowbird. *Nature (London)*, 299(5886), 818-820.
- Andersson, M. (1994). *Sexual Selection*. Princeton: Princeton University Press.
- Dennett, D. C. (1996). *Kinds of minds: towards an understanding of consciousness*. New York: Simon and Schuster.
- Desimone, R. (1998). Visual attention mediated by biased competition in extrastriate visual cortex. *Philosophical Transactions of the Royal Society of London B*, 353, 1245-1255.
- Dukas, R. (2002). Behavioural and ecological consequences of limited attention. *Philosophical Transactions of the Royal Society of London B*, 357(1427), 1539-1547.
- Dukas, R., & Kamil, A. C. (2000). The cost of limited attention in blue jays. *Behavioral Ecology*, 11(5), 502-506.
- Dukas, R., & Kamil, A. C. (2001). Limited attention: The constraint underlying search image. *Behavioral Ecology*, 12(2), 192-199.
- Endler, J. A. (1992). Signals, signal conditions, and the direction of evolution. *The American Naturalist*, 139 (Suppl.), S125-S153.
- Endler, J. A., & Basolo, A. L. (1998). Sensory ecology, receiver biases and sexual selection. *Trends in Ecology & Evolution*, 13(10), 415-420.

- Guilford, T., & Dawkins, M. S. (1991). Receiver psychology and the evolution of animal signals. *Animal Behaviour*, *42*, 1-14.
- Harland, D. P., & Jackson, R. R. (2000). 'Eight-legged cats' and how they see - a review of recent research on jumping spiders (Araneae: Salticidae). *Cimbebasia*, *16*, 231-240.
- Jackson, R. R. (1982). Habituation as a mechanism of intersexual selection. *Journal of Theoretical Biology*, *97*, 333-335.
- Jackson, R. R., & Pollard, S. D. (1996). Predatory behavior of jumping spiders. *Annual Review of Entomology*, *41*, 287-308.
- Jackson, R. R., & Pollard, S. D. (1997). Jumping spider mating strategies: sex among cannibals in and out of webs. In J. C. Choe & B. J. Crespi (Eds.), *The evolution of mating systems in insects and arachnids*. (pp. 340-351). Cambridge: Cambridge University Press.
- Jackson, R. R., & Wilcox, R. S. (1998). Spider-eating spiders. *American Scientist*, *86*(4), 350-357.
- Kodric-Brown, A., & Johnson, S. C. (2002). Ultraviolet reflectance patterns of male guppies enhance their attractiveness to females. *Animal Behaviour*, *63*, 391-396.
- Lashley, K. S. (1949). Persistent problems in the evolution of mind. *Quarterly Review of Biology*, *24*, 28-42.
- Maunsell, J. H. R. (1995). The brain's visual world: Representation of visual targets in cerebral cortex. *Science*, *270*(5237), 764-768.
- Minsky, M. (1986). *The society of mind*. New York: Simon and Schuster.

- Montgomery, T. H. (1908). Further studies on the activities of araneids. *American Naturalist*, 42(697-709).
- Montgomery, T. H. (1909). Further studies on the activities of Araneids. II. *Proceedings of the National Academy of Sciences of the United States of America*, 61, 548-569.
- Noonan, K. C. (1983). Female mate choice in the cichlid fish *Cichlasoma nigrofasciatum*. *Animal Behaviour*, 31(4), 1005-1010.
- Palmer, S. E. (1999). *Vision science: photons to phenomenology*. Cambridge, Massachusetts: MIT Press.
- Pashler, H. E. (1998). *The psychology of attention*. Cambridge, Massachusetts: MIT Press.
- Peckham, G. W., & Peckham, E. G. (1889). Observations on sexual selection in spiders of the family Attidae. *Occasional Papers of the Wisconsin Natural History Society*, 1, 3-60.
- Peckham, G. W., & Peckham, E. G. (1890). Additional observations on sexual selection in spiders of the family Attidae. *Occasional Papers of the Wisconsin Natural History Society*, 1, 117-151.
- Proctor, H. C. (1992). Sensory exploitation and the evolution of male mating behaviour: A cladistic test using water mites (Acari: Parasitengona). *Animal Behaviour*, 44(4), 745-752.
- Rees, G., Frith, C. D., & Lavie, N. (1997). Modulating irrelevant motion perception by varying attentional load in an unrelated task. *Science*, 278(5343), 1616-1619.
- Rensch, B. (1956). Increase in learning capability with increase of brain-size. *American Naturalist*, 90, 81-95.

- Schiffman, H. R. (1996). *Sensation and perception: An integrated approach* (4th ed.). Oxford: John Wiley & Sons.
- Shettleworth, S. J. (1998). *Cognition, Evolution, and Behavior*. New York: Oxford University Press.
- Shettleworth, S. J. (2001). Animal cognition and animal behaviour. *Animal Behaviour*, *61*, 277-286.
- Swaddle, J. P., & Cuthill, I. C. (1994). Preference for symmetric males by female zebra finches. *Nature*, *367*(6459), 165-166.
- Trivers, R. L. (1972). Parental investment and sexual selection. In B. Campbell (Ed.), *Sexual selection and the descent of man* (pp. 136-179). Chicago: Aldine.

ACKNOWLEDGEMENTS

My work was based in the Canterbury Spider Laboratory, an MAF-approved quarantine facility. This facility has been made possible by the efforts of numerous staff at MAF and in the Zoology Department. In particular, I would like to thank Andrew Pavitt (MAF) and Linda Morris, Nick Etheridge, Tracey Robinson, John Scott and Gavin Robinson (Zoology Department).

Much of the experimental data in this thesis was possible only because of the assistance of the International Centre for Insect Physiology and Ecology (ICIPE) in Kenya. In particular, the experimental work that required living *Anopheles* mosquitoes could not be done in the New Zealand laboratory. The laboratory's quarantine status is only for spiders. For their critical help with these experiments based on living mosquitoes, I thank the following ICIPE technical staff: Godfrey Sune, Silas Orima and Stephen Alluoch. At ICIPE's Mbita Point Field Station in Kenya, Godfrey, Silas and Stephen did the testing required for these experiments, providing the data that I analyzed and interpreted. Without their dedicated help, much of the work reported in this thesis would not have been possible. However, the interest and support of many other ICIPE staff was important. In particular, I would like to acknowledge Hans Herren (Director General, ICIPE), Charles Mwedia (Manager of the Mbita Point Field Station), John Githure (head of the ICIPE malaria project) and Louis Gouagna (head of the Mbita branch of the ICIPE malaria project). The Kenya Wildlife Division and the National Museums of Kenya, along with the staff of ICIPE, are acknowledged for their assistance with export of the spiders used for establishing research cultures in the New Zealand laboratory.

The research in this thesis was supported in part by the following grants of my supervisor: National Geographic Society grant 76705-00, University of Canterbury Research Grant U6525 and N.Z. Royal Society Linkage Grant #4882.

Speaking of my supervisor, Robert Jackson has helped me immensely with my thesis. Robert, I was really hoping that I could have a supervisor who could help me improve my writing skills. I like writing because there is always something new for me to learn, so that my style can improve, and I know that I have learned a lot about writing by having you as my supervisor. Thank you so much for reading my chapters when I knew that you were extremely busy! Also, it was so wonderful to have you as a supervisor because you are enthusiastic about your research. I never thought that I would ever work with spiders (incidentally, did you know that I used to be terrified of them?) but your passion for your field is infectious!! Thank you also for your encouragement (especially during difficult times), and for taking the news about the microwave fire so well (I thought I was going to get eaten for that!!). Also, thank you for helping me get into the Zoology Department in the first place. Without your encouragement, I would not be studying Zoology today!

I must also thank Simon Pollard for his help as my supervisor, and for organising the various social events for the Spider Lab. I think, though, that I aged about 10 years when I had to climb that mountain at Harihari (even though you assured me that it was perfectly safe)! Also, I am never going to see particular road signs the same way ever again! Besides this, thank you for your funny emails and various pictures of hippo skulls to cheer me up at numerous times.

Thank you also, Ewald Neumann, for your help as my supervisor. Thank you especially for getting me interested in Cognition in the first place. Your 4th year paper on this topic was one of the best courses I ever took in Psychology. I am now really interested in studying Cognition in the future. Thank you also for your interest in my thesis, even though you have never supervised a thesis on spider behaviour before!!

Thank you also to the other 'arachnophilic' students working in the spider lab while I was doing my research: Rebecca, Ximena, Kathryn and Ana. What a nice bunch of people to work with! I really enjoyed working with all of you. Thank you for helping me get settled into the lab and for your words of advice and encouragement.

The next people who I must thank are the members of my family. Thank you so much for so many things! Here is a list of all the things I need to thank you for: taking an interest in my thesis, taking an interest in spiders in general, investigating where to find the plants for my research (and bringing castor-oil plants down to Christchurch), helping me to catch mosquitoes for the spiders (and allowing yourselves to get bitten by some of them!), being there to talk to me when I was going through hard times, helping me financially, and oh, to remind me to never EVER give up!!

I also thank my friends for all their support while I have worked on my thesis. I thank you all for your emails, letters, phone calls, lunch/dinner invitations, Easter eggs for my birthday (they proved to be WONDERFUL study helpers!!) and for not passing out when I told you all that I was studying spiders (although some of you DID look close to passing out – I won't mention names!!). My pastors Mike and Lynn deserve a special mention for all their wonderful support, and for selflessly helping me out on many occasions (e.g., helping me move house, taking me to some doctor appointments, and so

on). Also, my acknowledgements would be incomplete without thanking my best friend for always being there for me.

As I have already alluded to, last year was not a very easy year for me (although I must say that working in the Spider Lab was a definite highlight!). I thank my doctors at Student Health and Christchurch Hospital for providing me with the appropriate medical treatment. I thank Dr. David Cole in particular for thinking that my spiders looked cute when I showed him pictures of them (as well as being an excellent doctor!). Dr. David Higgins in Tauranga deserves a special mention, because without his help, I may not have made it to university in the first place.

I also thank the people at Ilam Flats for providing me with a room to stay. However, Cassie Harris deserves a special mention for helping me out during one of my housing crises. There aren't many people who would willingly share their room for a month with someone they only met a few times previously. I also thank Carolyn Ford and Gareth Abdinor for their wonderful help in fighting StudyLink when my student allowance "expired." Let's hope that my appeal will help other students in the future.

Finally, how could I not thank my little eight-legged friends, *Evarcha culicivora* (otherwise known as "mosquito terminators," "little draculas," and "cutesy little spiders"!? Thank you for being such an interesting and inspiring animal to study. I'm looking forward to hearing more about you in the future!

