

#19

PROPERTY of ROBERT N. MERONEY
COLORADO STATE UNIVERSITY

REPORT ON NCAR BALLOON SHELTERS

by R. N. Meroney and
C. R. Symes

March 1970

NCAR

CER77-79-44a
68-69

Supplement to

REPORT ON NCAR BALLOON SHELTERS

prepared by

R. N. Meroney
Professor of Civil Engineering
Colorado State University

and

C. R. Symes

for

National Center of Atmospheric Research

March 1970

CER68-69RNM-CRS44a

SUPPLEMENT TO REPORT ON NCAR BALLOON SHELTERS

I. Introduction

Following the initial tests of Dr. E. J. Plate [see "Report on Balloon Shelter Tests," March 1969] it was decided that certain points required elaboration or confirmation. A further series of tests were requested concerning the following aspects:

- A. Quantitative measurement of the frequency and intensity of gusts shed from the upper edge and sides of the proposed shelter configurations,
- B. Examination of low velocity areas at the sides of the shelter for short distances downstream of the shelter,
- C. Detailed study of the effect of two pieces of bug-screen material in the shelter frame, set at 45° to each other,
- D. The effect of changes in the included angle on sheltered area and gusting, and,
- E. The effect of the presence of a balloon shape within the sheltered area upon the effectiveness of the shelter.

DESCRIPTION OF EXPERIMENTS

II. Visualization

For this series of experiments three different shelter angles were tested; 90 degrees, 120 degrees and 150 degrees included angle. Tests on the three shelters were performed with one piece of bug-screen held in the frame. A further test was carried out on the 120 degree shelter using two pieces of bug-screen held in the frame, set at 45 degrees to each other.

To obtain an estimate of the amount of flow deflected along a single upstream face of the 90° shelter smoke tracers were released upstream of the shelter. For very low free-stream velocities the majority of the smoke was deflected right along the upstream face (see photograph 1). For higher freestream velocities the smoke passed through the screen about halfway along the screen surface (see photograph 2). With the balloon model placed behind the screen the smoke pattern was not observably changed.

The other visualization technique involved looking at the motion of a small cork ball which was attached by thread to a long wire rod. Holding the wire rod from outside the flow field, the ball could be located at positions about the shelter. The areas of main interest were the shelter sides and top edges. No rotation of the ball was observed over the top edges, however at the side edges as the ball was drawn across a vertical side support (in the direction of decreasing Y), the rapid rotation of the ball changed direction abruptly. A short distance inside the support (that is, in the sheltered region) the ball rotation slowed and ceased.

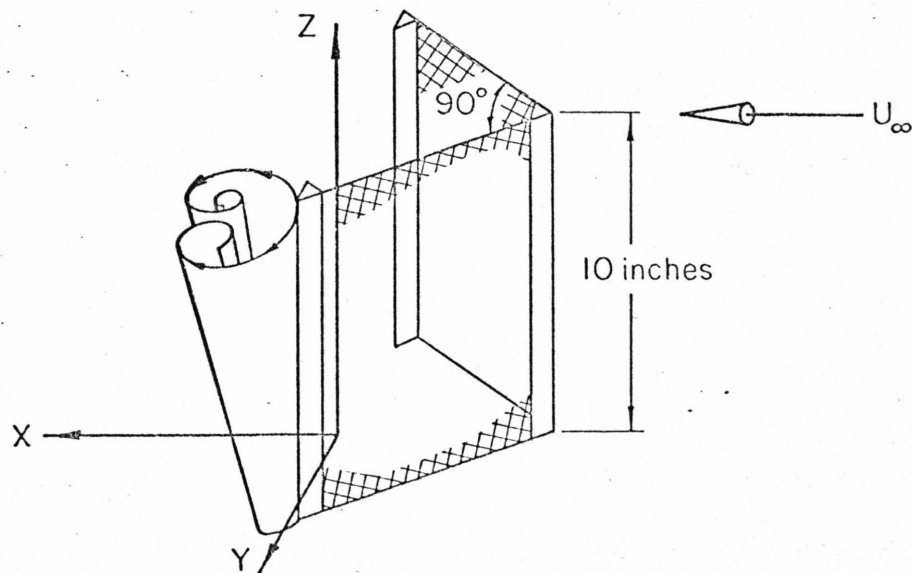

It is felt that this vortex phenomena at the shelter edges is due entirely to the vertical supports. The direction of the outer vortex follows that percentage of flow deflected along the screen and the freestream flow as it sweeps around the trailing edges, while the opposing direction of rotation of the inner vortex is due to the flow passed through the screen near to the support.

III. Velocity Profiles

Using a co-ordinate system where X is the distance downstream measured from the shelter trailing edge, Y is the transverse co-ordinate measured from the screen center line and Z is in the vertical direction, velocity measurements were taken for $X = 0(3)15$, $Y = 0(3)9$ and $Z = 0(5)15$ inches, (only one side of the shelter need be considered in view of the symmetry of the shelter about the XZ plane.)

Velocities were obtained using a pitot-static tube with a Transonic pressure transducer. A freestream velocity range of 20 feet per second to 50 feet per second was used on the 3 different shelters. The results of these measurements appear in Table 1.

IV. Turbulence Intensity

It became clear that one area of major interest was the side edges of a shelter. Further examination of this area involved measuring turbulence intensities and taking frequency analyses of the eddy shedding at the edges. Turbulence intensities were measure using a Disa constant temperature anemometer, type 55A01.

V. Frequency Spectrum Analysis

The signal from the anemometer was displayed on an oscilloscope and analyzed using General Radio's Graphic Level Recorder type 1510-A, coupled to a Sound and Vibration Analyzer, type 1911-A.

VI. Pressure Coefficient

The pressure coefficients (as defined by Dr. Plate) for the single screen and double screen (described previously) were obtained by stretching the material across a 2 foot square section of the micro-wind tunnel and measuring static pressure drop across the screen and the velocity behind the screen.

DISCUSSION

I. Visualization

From the techniques described it appears that all shelter angles give approximately the same sheltered region with a velocity reduction of about 50 percent. Eddy shedding is an important feature but is confined to the side edges of the shelter and does not affect the sheltered area. No other large scale vortices related to the shelter geometry were observed.

With the wooden balloon model in place a marked decrease in velocity on the centerline with an increase around the sides and over the top of the balloon was observed. A short distance downstream these two effects seemed to combine to produce a flow pattern similar to that of the "no balloon" case.

II. Quantitative Effect of Included Angle, Screen Material and Balloon Presence.

The velocity reduction behind the shelters for the different configurations appear in Table 1. For the single screen shelter the velocity reduction for all angles was over 50 percent. For the double screen shelter the reduction was about 75 percent with pressure coefficient increasing to twice that of the single screen case.

Two dimensionless parameters, ξ , a mass flux parameter and ψ , a momentum flux parameter were defined,

$$\xi = \frac{\int_0^y \rho u_d dy}{\rho U_\infty L}$$

and

$$\psi = \frac{\int_0^y \rho u_d (U_\infty - u_d) dy}{\rho U_\infty^2 L}$$



u_d is the defect velocity behind the shelter (i.e., those velocities in Table 1), U_∞ is the freestream velocity and L is the total width of the shelter ($L = 12$ inches). These parameters were calculated for the wake of the different shelters and are tabulated in Tables 3 and 4. It can be seen that there is little variation in the parameters over the set of single screen shelters suggesting that shelter shape has little effect on the downstream region. In the double screen case, the decrease in these parameters is consistent with our intuition. Again little variation is seen over the range of freestream velocities.

III. Turbulence Intensity

Using the Disa hot-wire anemometer the turbulence intensity distribution around the shelters was investigated. The freestream turbulence level was about 3 percent. Behind the screen section of a shelter the turbulence level was very low (4 percent), but on the centerline (i.e., behind the center support) the level rose to 20 percent. The effect was most marked at the edges, 40 percent intensity being the general value. These high values at the edges are consistent with the vortex ball investigation. The vortex ball, however, failed to indicate the relatively high turbulence level due to the center support.

IV. Spectral Analysis

The signal from the anemometer was subjected to a frequency spectrum analysis, the eddy shedding frequency at the edges being the major area of interest. The expected frequency of the dominant eddies, given approximately by the Strouhal frequency, was of the order 10 Hz. Extensive investigation failed to isolate this frequency. It is felt that the low frequency limit of the equipment was responsible for this deficiency.

CONCLUSIONS

1. The shelter angle has no noticeable effect on velocity reduction, turbulence level or flow pattern.
2. Velocity reduction for all angles with single screen is over 50 percent with 75 percent reduction in the double screen case. The pressure coefficient is doubled for the double screen case. $\Rightarrow C_D$ doubled.
3. The balloon presence produces higher velocities around the balloon surface. Downstream the flow pattern returns to the "no balloon" case.
4. Large eddy shedding at the edges could interact with the ¹balloon if the shelter was too narrow. X
5. The "necking-in" mentioned in the previous proposal is a misnomer for the blockage due to the vertical side supports. The velocity decrease behind these supports recovers quickly with distance downstream. This can be clearly seen in Fig. 1.

6. Turbulence behind & about balloon. See Table 2.

7. Increase in ξ for balloon presence case.
(90° shelter). see table 3

TABLE 1
VELOCITY PROFILES (FEET/SECOND)
 X, Y, Z Co-ordinates in Inches

90 Degree Shelter (No Balloon)

$U_{\infty} = 19.0$ Ft./Sec.

Z = 5 Inches

15	12	9	6	3	
6.83	5.94	-	7.04	7.24	
9.04	8.01	-	9.66	9.66	3
10.10	8.37	-	8.01	2.41	6
16.20	15.27	-	16.20	15.74	9

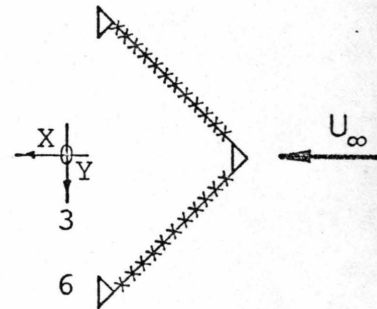

Z = 10 Inches

15	12	9	6	3	
10.80	9.04	-	7.04	7.04	
9.35	9.35	-	9.66	10.10	3
10.80	10.10	-	10.10	4.52	6
17.91	18.71	-	17.91	17.91	9

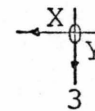

$U_{\infty} = 31.5$ Ft./Sec.

Z = 5 Inches

15	12	9	6	3	
11.46	11.46	-	12.19	13.23	
15.74	16.20	-	17.08	18.71	3
17.08	16.20	-	13.77	8.71	6
27.53	27.00	-	28.06	28.08	9

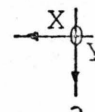

Z = 10 Inches

15	12	9	6	3	
19.47	18.71	-	13.23	12.55	
17.08	17.08	-	17.91	18.71	
18.71	19.47	-	17.91	10.80	
31.02	30.55	-	29.58	30.55	

$U_{\infty} = 48.6 \text{ Ft./Sec.}$

Z = 5 Inches

15	12	9	6	3	
17.08	17.08	-	18.71	18.71	
24.15	24.15	-	25.90	26.45	
24.75	24.15	-	20.91	10.80	
40.41	39.68	-	40.77	39.68	

Z = 10 Inches

15	12	9	6	3	
28.06	25.33	-	19.47	17.91	
25.33	25.33	-	26.45	27.53	
27.53	27.53	-	28.06	18.71	
43.20	42.52	-	43.20	43.20	

90 Degree Shelter (with Balloon)

$U_{\infty} = 19.0 \text{ Ft./Sec.}$

$Z = 5 \text{ Inches}$

15	12	9	6	3	
-	-	2.41	3.82	2.53	
6.39	-	6.16	7.04	12.07	
9.04	-	8.87	8.87	7.64	
-	-	16.64	16.73	16.64	

$Z = 10 \text{ Inches}$

15	12	9	6	3	
-	-	10.25	9.81	10.25	
10.10	-	10.66	11.33	12.07	
9.96	-	10.25	10.25	10.10	
-	-	18.31	18.47	18.55	

120 Degree Shelter (No Balloon)

$U_{\infty} = 19.0 \text{ Ft./Sec.}$

Z = 5 Inches

	12	9	6	3	
	5.66	5.92	6.39	7.24	
	8.01	8.37	8.71	9.96	
	8.17	8.37	7.83	3.82	
	16.11	16.02	16.20	16.38	

Z = 10 Inches

	12	9	6	3	
	6.39	6.39	6.61	6.61	
	8.54	8.87	9.35	9.96	
	8.54	8.19	7.44	3.82	
	16.90	17.50	17.50	18.15	

120 Degree Double Screen Shelter (No Balloon)

$U_{\infty} = 19.0 \text{ Ft./Sec.}$

$Z = 5 \text{ Inches}$

12	9	6	3	
3.82	4.00	4.52	5.40	
4.83	5.26	5.79	6.61	
4.97	5.12	5.53	2.96	
13.77	14.79	16.20	16.64	

$Z = 10 \text{ Inches}$

12	9	6	3	
3.82	4.18	4.83	6.27	
4.83	4.83	5.12	5.66	
5.26	5.26	5.26	2.41	
15.74	17.08	17.66	17.50	

$U_{\infty} = 31.5 \text{ Ft./Sec.}$

$Z = 5 \text{ Inches}$

12	9	6	3	
5.40	5.92	6.83	8.87	
8.37	9.35	10.10	11.20	
8.87	9.20	9.20	5.4	
24.75	26.45	27.53	27.00	

$Z = 10 \text{ Inches}$

12	9	6	3	
5.92	6.61	8.01	9.81	
8.20	8.87	9.81	11.33	
9.35	9.35	9.35	3.19	
25.90	26.45	29.08	29.08	

$U_{\infty} = 48.6 \text{ Ft./Sec.}$

Z = 5 Inches

12	9	6	3	
6.61	8.01	9.35	11.33	
11.83	13.77	15.27	17.08	3
13.12	13.77	13.77	14.08	6
36.62	37.41	39.68	39.68	9

Z = 10 Inches

12	9	6	3	
8.54	9.20	10.80	13.23	
12.55	14.29	14.69	17.50	3
14.39	14.69	15.08	13.77	6
40.77	40.05	42.86	42.86	9

150 Degree Shelter (No Balloon)

$U_{\infty} = 19.0 \text{ Ft./Sec.}$

Z = 5 Inches

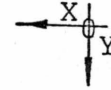

No Measurements taken

Z = 10 Inches

15	12	9	6	3	
-	-	7.64	6.61	6.16	
7.83	8.19	8.37	8.71	8.87	3
9.35	-	8.37	7.44	5.40	6
-	-	18.31	18.31	18.23	9

150 Degree Shelter (With Balloon)

$U_{\infty} = 19.0$ Ft./Sec.

Z = 5 Inches

No Measurements Taken

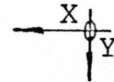

Z = 10 Inches

12	9	6	3	
8.54	8.87	10.39	-	
9.35	10.10	11.20	-	3
9.66	9.35	8.71	-	6
19.02	19.09	19.09	-	9

TABLE 2

TURBULENCE INTENSITY (DIMENSIONLESS)

90 Degree Shelter (No Balloon)

$U_{\infty} = 9.96 \text{ Ft./Sec.}$

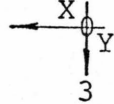
Z = 5 INCHES

12	9	6	3	X_{0Y}
			0.1387	
			0.0380	3
			0.4374	6
			0.0453	9

Z = 10 INCHES

12	9	6	3	X_{0Y}
			0.1904	
			0.0332	3
			0.4582	6
			0.0380	9

Z = 15 INCHES

3	X_{0Y}
0.0254	
(For all Y)	

90 Degree Shelter (No Balloon)

$U_{\infty} = 19.0 \text{ Ft./Sec.}$

Z = 5 INCHES

12	9	6	3	$X_0 Y$
0.1291	0.1460	0.1508	0.1497	
0.0619	0.0517	0.0446	0.0447	3
0.1538	0.1896	0.2701	0.4688	6
0.0722	0.0579	0.0525	0.047	9

Z = 10 INCHES

12	9	6	3	$X_0 Y$
0.2649	0.2398	0.2011	0.1953	
0.0926	0.0659	0.0479	0.0386	3
0.1532	0.1799	0.2352	0.3756	6
0.0567	0.0451	0.0391	0.0379	9

Z = 15 INCHES

12	9	6	3	$X_0 Y$
0.0303	0.0285	0.0285	0.0270	

(For all Y)

90 Degree Shelter (With Balloon)

$U_{\infty} = 19.0 \text{ Ft./Sec.}$

Z = 5 INCHES

15	12	9	6	3	X_{0Y}
-	-	0.5704	0.4300	0.4221	
0.3181	-	0.4029	0.3571	0.1247	3
0.1679	-	0.1673	0.2286	0.3893	6
-	-	0.0517	0.0478	0.0454	9

Z = 10 INCHES

15	12	9	6	3	X_{0Y}
-	-	0.3287	0.3295	0.3721	
0.1880	-	0.1661	0.1146	0.0464	3
0.1536	-	0.1750	0.2196	0.3304	6
-	-	0.0478	0.0401	0.0568	9

150 Degree Shelter (No Balloon)

$U_{\infty} = 19.0 \text{ Ft./Sec.}$

Z = 5 INCHES

$X_0 Y$

No measurements taken

Z = 10 INCHES

15	12	9	6	3	$X_0 Y$
-	-	0.2338	0.3214	0.3437	
0.1056	0.1002	0.0814	0.0714	0.0667	3
0.1504	-	0.2148	0.2721	0.3580	6
-	-	0.1107	0.0913	0.0410	9

150 Degree Shelter (With Balloon)

$U_{\infty} = 19.0 \text{ Ft./Sec.}$

Z = 5 INCHES

No measurements taken

$X_0 Y$

Z = 10 INCHES

15	12	9	6	3	
-	.2954	0.3108	0.3613	-	$X_0 Y$
-	0.1969	0.1910	0.1163	-	3
-	0.1468	0.1450	0.1880	-	6
-	0.0726	0.0517	0.0431	-	9

TABLE 3

MASS FLUX PARAMETER ξ (DIMENSIONLESS)

ξ is calculated for the various freestream velocities at $Z = 10$ and X coordinate shown below.

90 Degree Shelter (No Balloon)

	X = 3	X = 6	X = 12	X = 15
$U_{\infty} = 19.0$	0.48	0.57	0.58	0.61
$U_{\infty} = 31.5$	0.54	0.61	0.65	0.65
$U_{\infty} = 48.6$	0.52	0.59	0.59	0.61

90 Degree Shelter (With Balloon)

	X = 3	X = 6	X = 9
$U_{\infty} = 19.0$	0.64	0.63	0.62

120 Degree Shelter (No Balloon)

	X = 3	X = 6	X = 9	X = 12
$U_{\infty} = 19.0$	0.46	0.51	0.51	0.50

120 Degree Double Screen Shelter (No Balloon)

	X = 3	X = 6	X = 9	X = 12
$U_{\infty} = 19.0$	0.35	0.38	0.38	0.35
$U_{\infty} = 31.5$	0.36	0.40	0.37	0.35
$U_{\infty} = 48.6$	0.41	0.39	0.37	0.35

150 Degree Shelter (No Balloon)

	X = 3	X = 6	X = 9
$U_{\infty} = 19.0$	0.46	0.50	0.52

150 Degree Shelter (With Balloon)

	X = 6	X = 9	X = 12
$U_{\infty} = 19.0$	0.61	0.59	0.58

TABLE 4

MOMENTUM FLUX PARAMETER ψ (DIMENSIONLESS)

ψ calculated for the various freestream velocities at $Z = 10$ and X coordinate shown below.

90 Degree Shelter (No Balloon)

	X = 6	X = 12	X = 15
$U_{\infty} = 19.0$	0.21	0.21	0.22
$U_{\infty} = 31.5$		0.21	0.21
$U_{\infty} = 48.6$		0.23	0.22

90 Degree Shelter (With Balloon)

	X = 6	X = 9
$U_{\infty} = 19.0$	0.21	0.21

120 Degree Shelter (No Balloon)

	X = 12	X = 15
$U_{\infty} = 19.0$	0.21	0.22

120 Degree Double Screen Shelter (No Balloon)

	X = 12	X = 15
$U_{\infty} = 19.0$	0.17	0.18
$U_{\infty} = 31.5$	0.19	0.18
$U_{\infty} = 48.6$	0.19	0.18

150 Degree Shelter (No Balloon)

	X = 6	X = 9
$U_{\infty} = 19.0$	0.21	0.21

150 Degree Shelter (With Balloon)

	X = 6	X = 9	X = 12
$U_{\infty} = 19.0$	0.20	0.21	0.21

FIG. 1. ISOVELS.

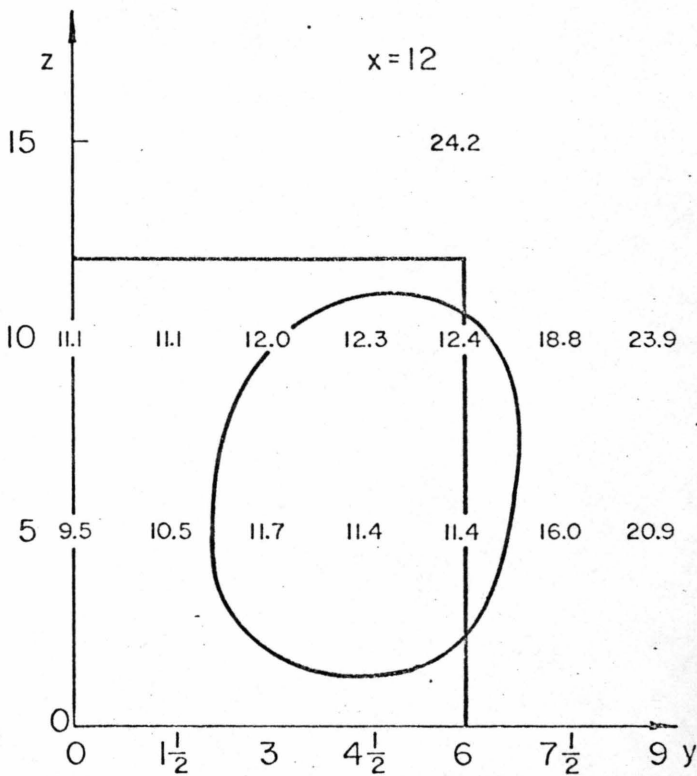
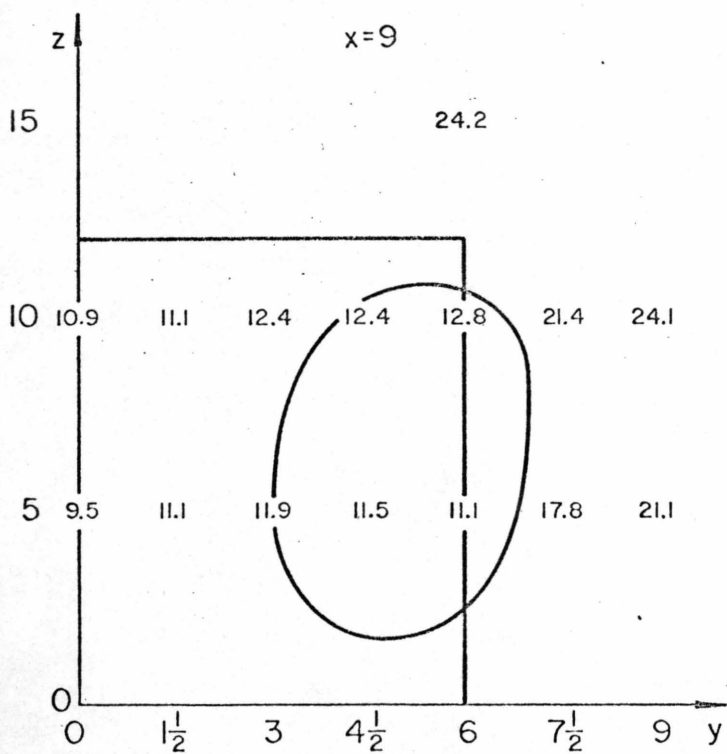
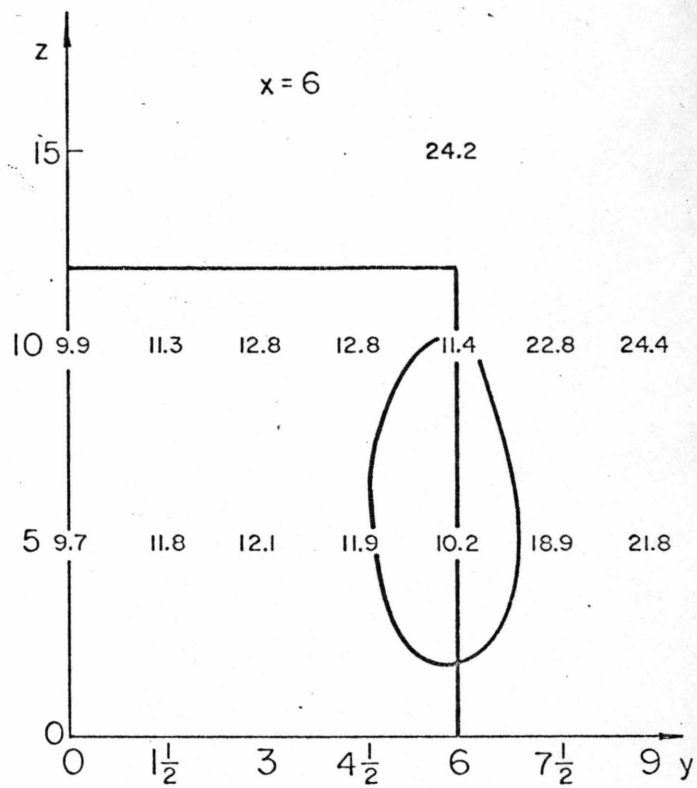
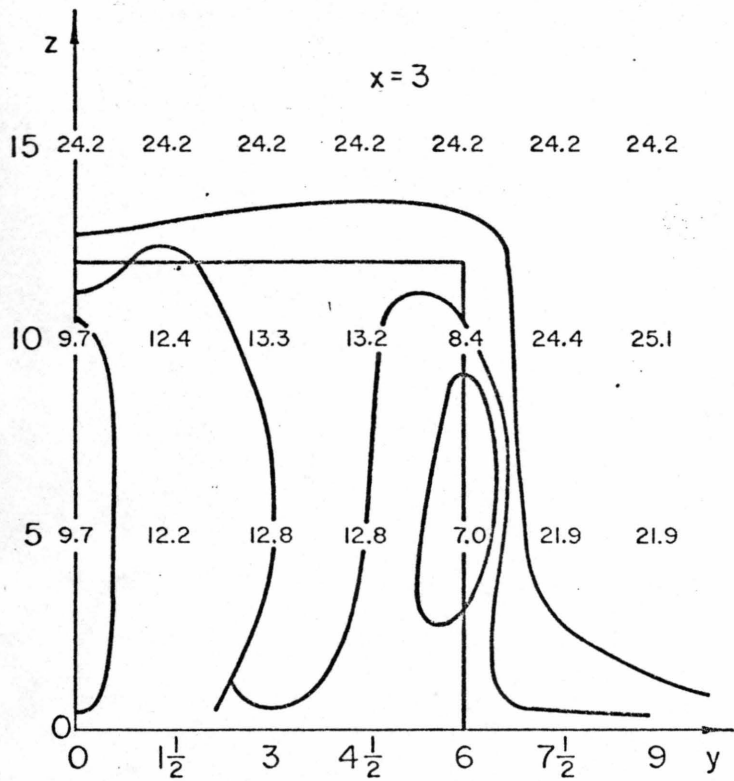

Fig. 2 Equipment lay-out

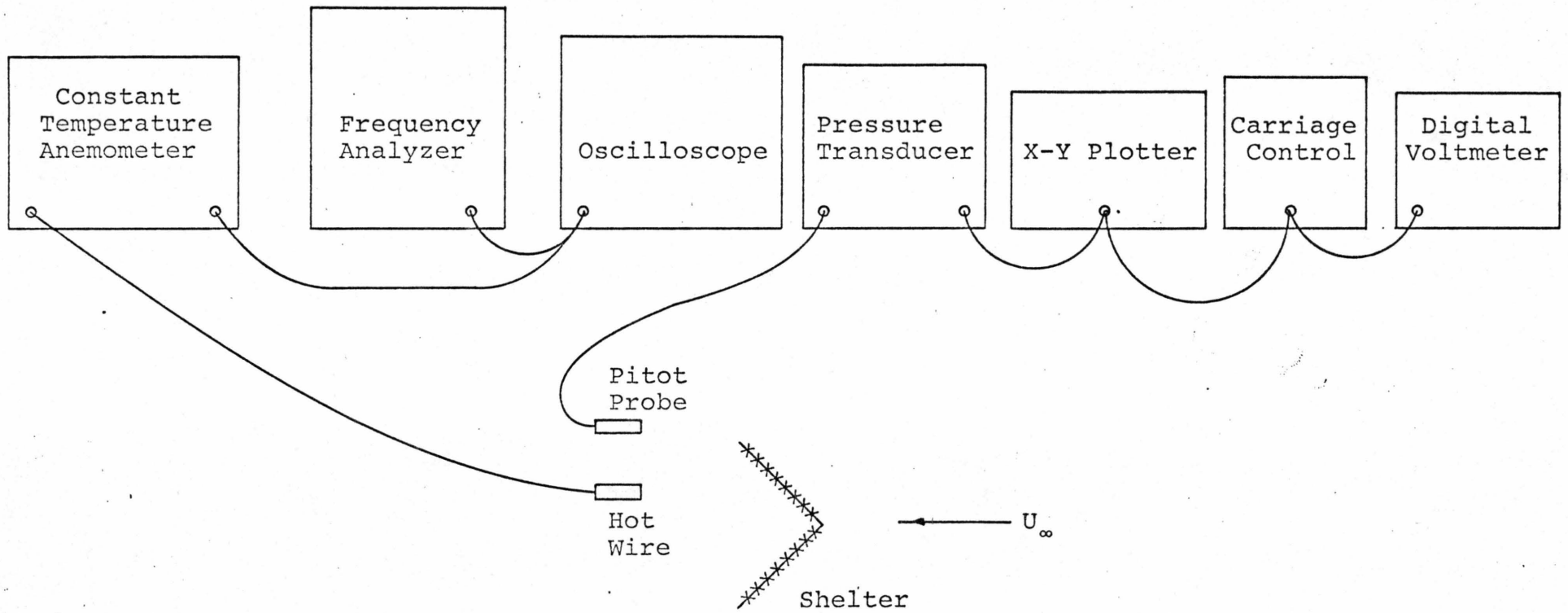

PHOTO 1
 $U_{\infty} = 5 \text{ Ft./Sec.}$

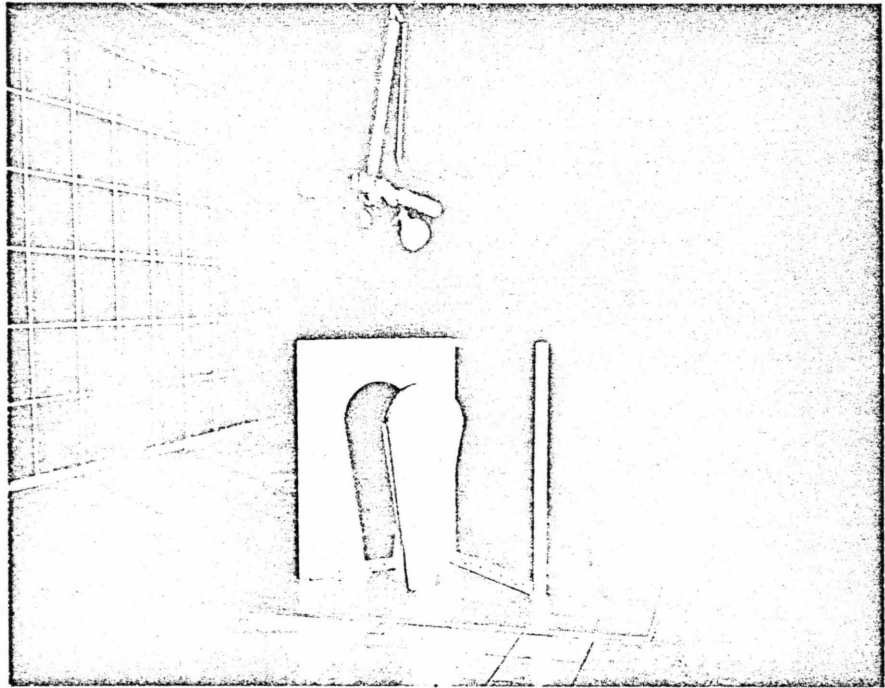

PHOTO 2
 $U_{\infty} = 15 \text{ Ft./Sec.}$

