

*Bind for M. A. Laboratory*

PLANNING SEDIMENT DISTRIBUTION IN  
SURFACE IRRIGATION SYSTEMS

Water Management Technical Report No. 26

by

Khalid Mahmood

Prepared under support of

United States Agency for International Development  
Contract No. AID/csd-2162  
Water Management Research  
in Arid and Sub-Humid Lands of the  
Less Developed Countries

Colorado State University

Fort Collins, Colorado

November 1971

CER73-74KM19

Mahmood, Khalid. Planning Sediment Distribution in Surface Irrigation Systems. Council of U.S. Universities for Soil and Water Development in Arid and Sub-Humid Areas. Technical Report No. 26. Fort Collins: Colorado State University, 3 December 1973.

#### ABSTRACT

This report deals with planning sediment load distribution in surface irrigation systems. The object is to route water and sediment through an irrigation canal network so that sediment discharge equilibrium is achieved by diverting the sediment inflow with the farm supplies. A computer-simulated canal network is used for the routing, and following problems are identified:

(1) The sediment transport capacity in a branching canal network reduces in the downstream direction, mainly because smaller channels cannot transport their proportional share of the sediment load in the system.

(2) The sediment transport capacity of farm watercourse channels is especially limited, and sediment discharge nonequilibrium in these channels can cause frequent interruption to farm water deliveries.

(3) Sediment inflow on farm units necessitates recurrent land levelling.

General principles for planning the sediment routing are derived. Results of laboratory and computer studies of sediment withdrawal in farm turnouts are also presented. The design of system components, so as to achieve sediment discharge equilibrium, is illustrated by a numerical example. Subject areas, where existing knowledge is deficient or unavailable, are also identified; and specific topics for field research are suggested.

## TABLE OF CONTENTS

| <u>Chapter</u>  | <u>Page</u> |
|---|-------------|
| LIST OF FIGURES . . . . .   | iv          |
| LIST OF TABLES . . . . .  | v           |
| LIST OF APPENDICES . . . . .  | v           |
| <br>  |             |
| I INTRODUCTION . . . . .  | 1           |
| Acknowledgments . . . . .   | 5           |
| <br>  |             |
| II SEDIMENT PROBLEM . . . . .   | 6           |
| Background . . . . .  | 6           |
| Problems in Canal System . . . . .  | 7           |
| Problems in On-Farm Water Management . . . . .                              | 10          |
| <br>  |             |
| III SUMMARY OF RESEARCH. . . . .  | 13          |
| Sediment Distribution in Irrigation Canal Systems. . . . .                  | 13          |
| Laboratory Model Studies of Sediment Withdrawal in<br>Turnouts . . . . .    | 24          |
| Numerical Simulation of Sediment Withdrawal in<br>Turnouts . . . . .        | 33          |
| Sediment Transport Characteristics of Water Course<br>Channels . . . . .    | 36          |
| <br>  |             |
| IV APPLICATION OF RESULTS . . . . .   | 40          |
| Numerical Example. . . . .  | 40          |
| 1. Computations for the Design of Stable Alluvial<br>Channel . . . . .      | 40          |
| 2. Sediment Withdrawal Characteristics of Turnouts . . . . .                | 41          |
| 3. Required Bed Material Load in Turnouts . . . . .                         | 46          |
| 4. Design of Turnouts . . . . .   | 46          |
| 5. Water Course Bed Material. . . . .                                       | 48          |
| 6. Channel Geometry and Bed Material Transport in<br>Water Course . . . . . | 48          |
| 7. Resistance Function for the Water Course . . . . .                       | 52          |
| 8. Summary of Design. . . . .   | 54          |
| <br>  |             |
| V CONCLUSIONS. . . . .  | 55          |
| Summary. . . . .  | 55          |
| Recommendations for Further Research . . . . .                              | 57          |
| <br>  |             |
| REFERENCES CITED . . . . .  | 58          |

## LIST OF FIGURES

| <u>Figure</u> |  | <u>Page</u> |
|---------------|--|-------------|
| 1             | Schematic Distribution of Water and Sediment in Irrigation Canal Systems . . . . .   | 2           |
| 2             | Hydrographs of Discharge and Sediment Load Entering Lower Bari Doab Canal at Balloki Headworks, 1962-63. . . . .                   | 8           |
| 3             | Schematic Reduction of Water Delivery by a Water Course Due to Aggradation. . . . .  | 12          |
| 4             | Simulated Irrigation Canal System with 5,000 cfs Discharge at Headworks . . . . .  | 14          |
| 5             | Discharge and Channel Length Variation with Distance from Headworks in the Simulated Systems. . . . .                              | 15          |
| 6             | Schematic Arrangement of Laboratory Flume. . . . .   | 28          |
| 7             | Layout of Turnout in Laboratory Flume (plan view). . . . .   | 29          |
| 8             | Definition Sketch of Turnout Variables . . . . .   | 31          |
| 9             | Regions of Undisturbed Channel Flow Feeding the Turnout for Different Turnout Settings and Discharges in Channel (11,11) . . . . . | 42          |
| 10            | Cumulative Distribution of Water Discharge and Bed Material Load in Channel (11,11) Along Depth of Flow. . . . .                   | 44          |
| 11            | Variation of Bed Material Load Characteristics of Turnouts on Channel (11,11) with Turnout Setting $y_t$ . . . . .                 | 45          |

## LIST OF TABLES

| <u>Table</u> |   | <u>Page</u> |
|--------------|---|-------------|
| 1            | CRITERIA USED FOR SIMULATION OF IRRIGATION CANAL NETWORK SHOWN IN FIGURE 4. . . . .     | 16          |
| 2            | CHARACTERISTICS OF THE SIMULATED NETWORK (EXCLUDING FARM WATER COURSES). . . . .        | 17          |
| 3            | VARIATION OF THE SEDIMENT LOAD DISTRIBUTION PARAMETERS IN THE SIMULATED SYSTEM. . . . . | 25          |



LIST OF TABLES - Continued

| <u>Table</u> |   | <u>Page</u> |
|--------------|---|-------------|
| 4            | RANGE OF VARIABLES COVERED IN THE LABORATORY STUDY<br>ON TURNOUTS . . . . . | 27          |
| 5            | BED MATERIAL DISTRIBUTION AMONG TURNOUTS ON<br>CHANNEL (11,11) . . . . .    | 47          |

LIST OF APPENDICES

|     |  |    |
|-----|--|----|
| I   | NUMERICAL MODEL FOR DETERMINING SEDIMENT WITHDRAWAL<br>IN ORIFICE TYPE TURNOUTS. . . . . | 60 |
| II  | SIMILITUDE CRITERIA FOR SEDIMENT WITHDRAWAL<br>IN TURNOUTS . . . . .                     | 64 |
| III | HYDRAULIC ELEMENTS OF ELLIPTICAL CHANNELS . . . . .                                      | 66 |

## I. INTRODUCTION

The irrigation diversions from an alluvial river carry a sediment load that is related to the conditions in the river and the design of diversion structure. In the case of low head diversion structures on sand bed rivers, such as the barrages in Pakistan, the sediment content in irrigation diversions is substantial, at least during the high flow season. The sediment load then creates some major operational problems in the conveyance and distributary channels as well as in the on-farm water management.

The concept of sediment discharge equilibrium in irrigation canal systems is based on the continuity of mass of sediment in a system. The total sediment mass entering a system over a finite period of time equals the sum of sediment outflow from the system and the amount of sediment deposited in the system over the same period. In general, the sediment outflow from a system includes:

1. Sediment removed at the desilting works within the system (silt ejectors, settling tanks).
2. Sediment removed by periodic bed clearance of the channels in the system.
3. Sediment removed with the flow out of the system during accidents (breaches) and escape of surplus supplies.
4. Sediment load in the farm diversions.

The schematic distribution of water and sediment in irrigation canal systems is shown in Fig. 1. The relative magnitudes of sediment outflow by different modes vary with the design of a system. However, the amount of sediment that can be removed by each of these modes is also limited by other considerations. The silt ejectors require a

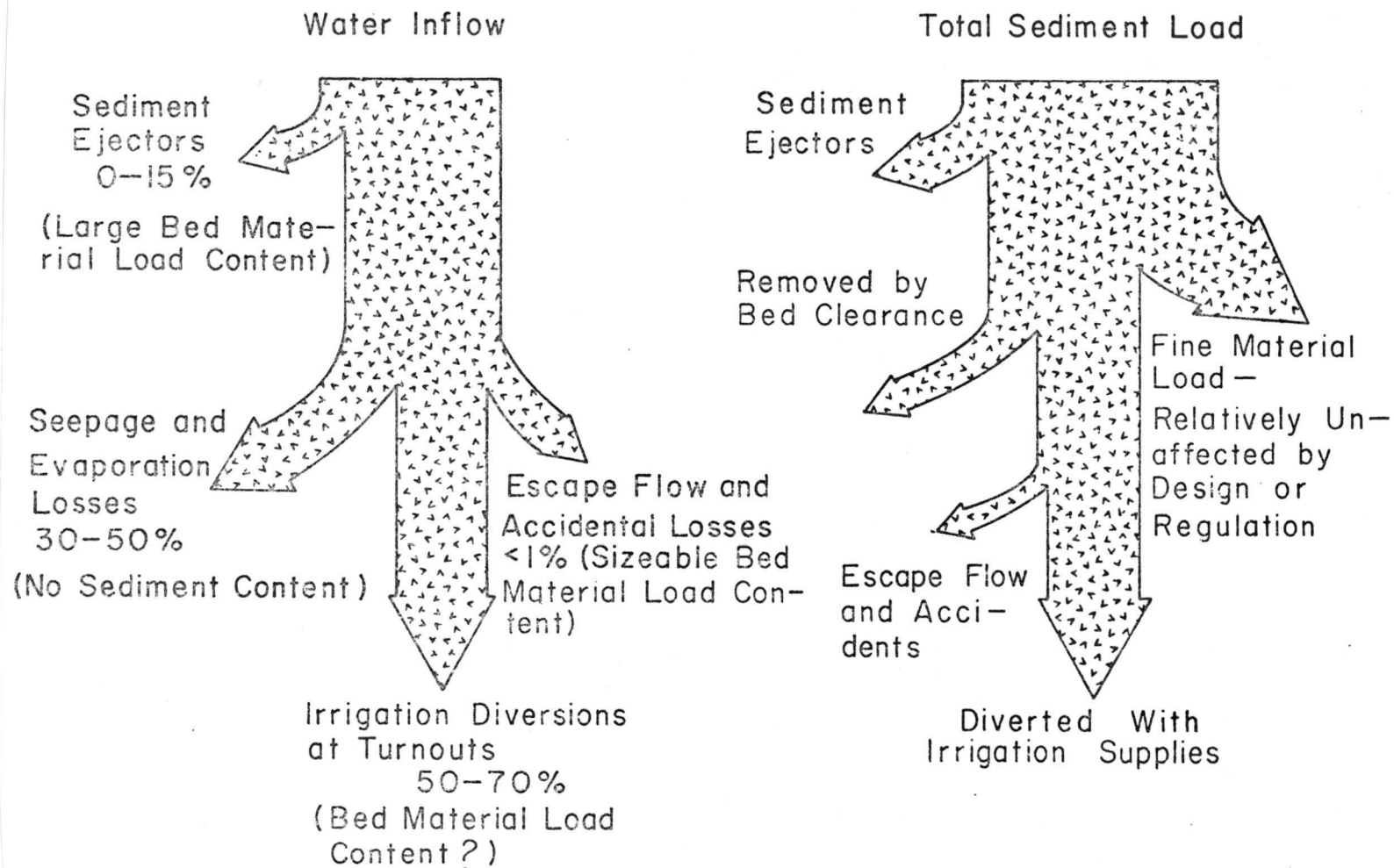

Figure 1. Schematic Distribution of Water and Sediment in Irrigation Canal Systems.

certain proportion of water discharge to remove and transport sediment away from the system. Their efficiency of desilting also levels off at about 10 to 15 percent discharge withdrawal. The settling tanks require large storage areas roughly equal to the volume of flow accumulation over the detention time. The bed clearance of channels can either be done by dredges or by excavation of the bed during closures. The dredging, because of the size of equipment, is adapted to large canals in the system. The bed excavation, on the other hand, can only be carried out when canal beds are in dry or near dry condition. The capacity of small watercourses to transport sediment is small, especially for the coarse sand fractions.

An irrigation canal system is considered in sediment discharge equilibrium when the total sediment inflow equals the sediment outflow over a finite period. If the system is not in equilibrium, the difference between the inflow and outflow is being stored in or removed from the system. In either case, the stability of the system is in jeopardy. For example, if sediment is being stored in the system (inflow greater than outflow), the channel beds in the system will aggrade and reduce the conveyance capacity of the system. The sediment discharge equilibrium of an irrigation canal system should, therefore, be properly planned.

The design of irrigation systems in Pakistan, India, Egypt and some other countries, has gradually evolved in the past with the increasing need for irrigation supplies. In these irrigation canal systems, it is recognized that sediment is a problem and that the unexcluded sediment must generally be disposed of on the lands of the water users. To develop means for disturbing sediment where it will do the least

harm, sediment withdrawal of farm turnouts was studied at Colorado State University under USAID Contract No. AID/csd-2162, Water Management Research in Arid and Sub-Humid Land of the Less Developed Countries. This study comprised experimental work on an orifice-type turnout in a recirculating sandbed flume at the Engineering Research Center of Colorado State University by Mr. Ata Nazar and Mr. A. Rakha. The experiments simulated farm turnouts on smaller distributary channels in the system (discharge intensities less than 2.5 cubic feet per second per foot width). A numerical model for simulating the flow and sediment withdrawal in farm turnouts on medium and large distributary channels (discharge intensity greater than 6.0 cubic feet per second per foot width) was developed by the writer under the same Contract.

The primary consideration in the turnout studies was related to the on-farm management problems created by sediment. However, in large irrigation canal networks, problems due to the quantity of sediment passing through farm turnouts are largely determined by the conditions in the system. This is especially true for the systems supplied by low head diversion structures on sandbed rivers. In such systems the sediment loads are substantial and the quantities accumulating over time are large so, if the sediment load is not properly managed throughout a system it may accumulate in one or more subsystems, stifling the conveyance channels by aggradation and disrupting the on-farm water delivery. The management of sediment in irrigation systems has not been previously studied in terms of the overall equilibrium of the system. Therefore, it was not apparent at the beginning of this study if and how sediment discharge equilibrium could be obtained in large systems that have sediment inflow. This aspect was studied by the writer on a computer simulated irrigation canal network.

This report deals with the planning of sediment discharge equilibrium in irrigation canal systems. It is assumed that a residual sediment load exists past the sediment exclusion and ejection measures at the head of the system, and that this load is to be routed to the farms. The report is based on the results of the preceding studies. For the sake of completeness, methods are also presented that can be used in designing the sediment withdrawal and transport through the turnouts and farm watercourse channels.

#### Acknowledgments

A number of persons have contributed to the completion of this report by their discussions and reviews. The writer acknowledges their help. Special thanks are due M. L. Albertson, D. B. Simons, W. D. Kemper, E. V. Richardson and A. G. Mercer, all at Colorado State University. The final draft was reviewed by W. D. Kemper, Project Director, Water Management Research Project. The laboratory study on turnouts was carried out by Messrs A. Rakha and A. Nazar as a part of their M.S. degree programs at Colorado State University.

The studies reported herein were partially supported by USAID Contract No.: AID/csd-2162, Water Management Research in Arid and Sub-Humid Land of the Less Developed Countries.

## II. SEDIMENT PROBLEM

Background

The sediment load entering an irrigation system may be divided into a wash load (also called the fine material load) and bed material load fractions. The bed-material fraction of the total sediment load in an alluvial channel comprises particle sizes that are available in the channel bed in appreciable quantities. The wash load fraction comprises particle sizes that are not found in appreciable quantities in the channel bed. This distinction is based on the predictability of the particular fraction from local conditions in an alluvial channel. The bed material load in an alluvial channel is related to the local bed and hydraulic conditions of the flow, while the wash load is not. For practical purposes in sandbed channels, the wash load and bed material load are considered to comprise the particle sizes smaller and larger than  $62 \mu$ , respectively.

In general, it is more difficult to remove fine material load from the irrigation supplies. The distribution of fine material concentration in the depth or width of an alluvial channel is nearly uniform. On the other hand, the bed material concentration is greater near the bed of an alluvial channel, and for channels curved in plan, the bed material concentration is greater near the convex bank. In a channel system, the distribution of fine material load at bifurcation and turnout structures is nearly proportional to the distribution of discharge and cannot be manipulated by the design of these structures. However, the bed material load distribution at these structures is affected by the design of structures and the channel flow. This distribution can, therefore, be manipulated at the control structures within a system.

The effect of sediment inflow over irrigation areas is also related to the size differentiation of the sediment load. For example, in clayey soils, the addition of bed material load with the irrigation supplies may be beneficial to the texture of the soil. And, in open textured soils the addition of fine material load may increase the water holding capacity. As the fine material load in irrigation systems cannot be controlled or predicted from local conditions, this report deals only with the bed material load fraction in sandbed channels.

In sandbed rivers with seasonal variations of discharge, the sediment load shows a marked seasonal variation closely related to the river discharge variation. This variation is also reflected in the sediment load entering a canal system. The hydrographs of discharge and sediment load concentration entering the Lower Bari Doab Canal system at Balloki Headworks for 1962-63 flow season are shown in Figure 2. It is seen that the total and bed material load concentrations are much higher during the spring and summer months. During periods of high sediment inflows, the channels in the head reach of the system store sediment in the bed and release it during periods of lower sediment inflows. The seasonal variation in the sediment inflow is thus dampened in the lower reaches of the system. If the water discharge in a system remains fairly constant, the sediment discharge equilibrium of such a system can be roughly approximated by the average bed material concentration over a season or a year.

#### Problems in Canal System

The sediment problems in a canal system, suffering from sediment discharge nonequilibrium, pertain to:



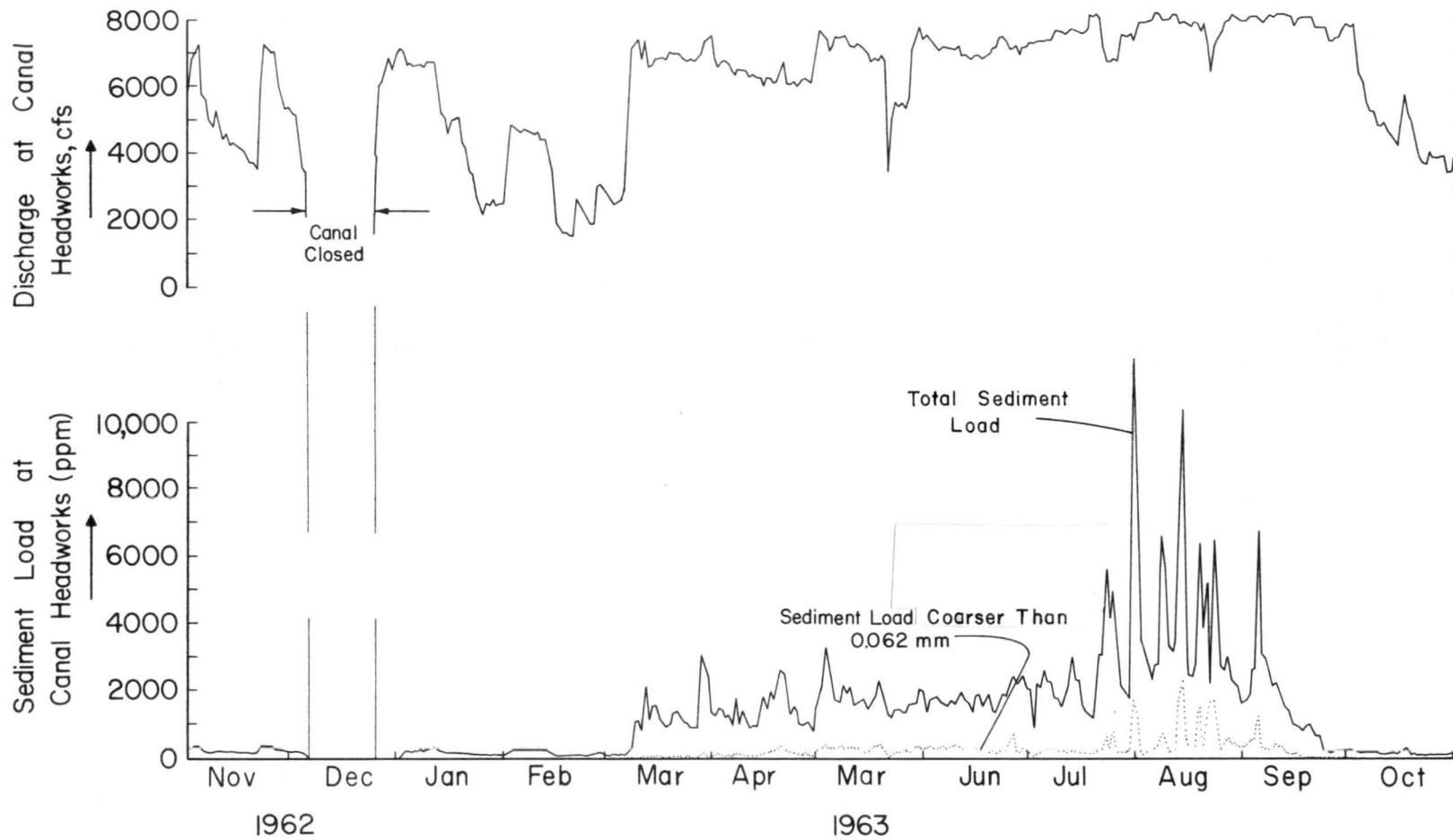

Figure 2. Hydrographs of Discharge and Sediment Load Entering Lower Bari Doab Canal at Balloki Headworks, 1962-63.

- (1) the instability of the channel sections, and
- (2) the loss of water conveyance capacity.

The channel instability can only occur in the unlined channels while the loss of conveyance capacity may occur in lined or unlined channels in a system.

If the sediment inflow in a system is greater than the sediment outflow, then the balance of the sediment load is being stored in the system. Consequently some channels in the system will aggrade. The unlined channels remain stable within a narrow range of hydraulic conditions. Experience with sandbed alluvial channels shows that these channels can become unstable by erosion of banks when their beds are aggrading. The channel aggradation also reduces the conveyance capacity of the system in two ways. In low head diversion structures on flat plains, as in Pakistan, the overall energy gradient available from the structure (and the canals) to the irrigated land is fairly restricted. The bed slope of an aggrading channel increases so that the water level at the head of the channel is higher than before. This increased water level can reduce the water intake of the channel below the design value and thus curtail the irrigation supplies available to the distribution system served by the channel. Similarly, if the aggradation is experienced in the main canal leading from the diversion structure, the conveyance capacity of the whole system may be reduced. The other effect of channel aggradation is to reduce the free board of the channel banks and thus reduce its safe conveyance capacity.

### Problems in On-Farm Water Management

The sediment problems in the on-farm management of water are caused by: (1) effect of sediment on the soil productivity; (2) the buildup of a part of the field due to sediment deposit; and (3) the aggradation of watercourses due to sediment deposit and a need for periodic cleaning.

The bed material component of the sediment load transported to the irrigation areas increases the proportion of sand size fraction in the top soil. This may be beneficial to the clayey soils. However, in open textured soil the addition of sand size material may adversely affect the soil productivity. In an irrigation system, if the bed material load is to be diverted with the irrigation supplies, the distribution of the load may be apportioned to various areas according to their capacities to absorb it without deteriorating their productivity. The sediment transported with the irrigation deliveries is deposited in the fields at the point of application. In basin irrigations, the deposit is concentrated close to the point where water enters the field, whereas in furrow irrigation it may be spread out a little in the downstream direction. This creates a need for recurrent land leveling of the fields. An indication of the frequency at which releveling of land would be necessary can be obtained as follows. Assume that sediment equilibrium in the canal and watercourse system is achieved so that all the diverted sediment at the headworks is deposited on the farms. If the diversion of water at the headworks is 4 feet per acre per year with a sediment content of 1000 ppm, and if all the sediment is deposited on 1/8 of the area nearest the delivery points, then this area would aggrade at the rate of about 0.3 inches per year which could necessitate releveling every five to ten years.

Watercourse channels leading from the turnouts to the fields are the most critical component in the overall bed material load distribution in an irrigation canal system. These channels are small with 1 to 5 cfs discharge capacity. They tend to have more vegetative growth and poor physical maintenance. As a result the unlined watercourses, with small flow capacities, flat slopes, and poor maintenance have a rather limited bed material transport capacity.

If the bed material inflow in a watercourse is larger than the transport capacity, the channel will aggrade. Further, if the energy gradient available from the distributary channel to the farm is restricted, the watercourse aggradation will lead to a reduction of discharge in the turnout. In such circumstances, the watercourses are cleaned by bed excavation and the spoil is dumped on the banks. The channel banks then become an additional source of sediment supply during rainfall and windstorms.

The effect of watercourse channel aggradation on the irrigation supply delivered to the farm is schematically shown in Fig. 3. This figure shows that if the bed material inflow in a watercourse channel is greater than the outflow, the effect of aggradation is to back up water at the turnout and then reduce the discharge. The water delivery in such a case reduces below the design discharge and frequent bed clearances of the channel are necessary to restore the water carrying capacity.

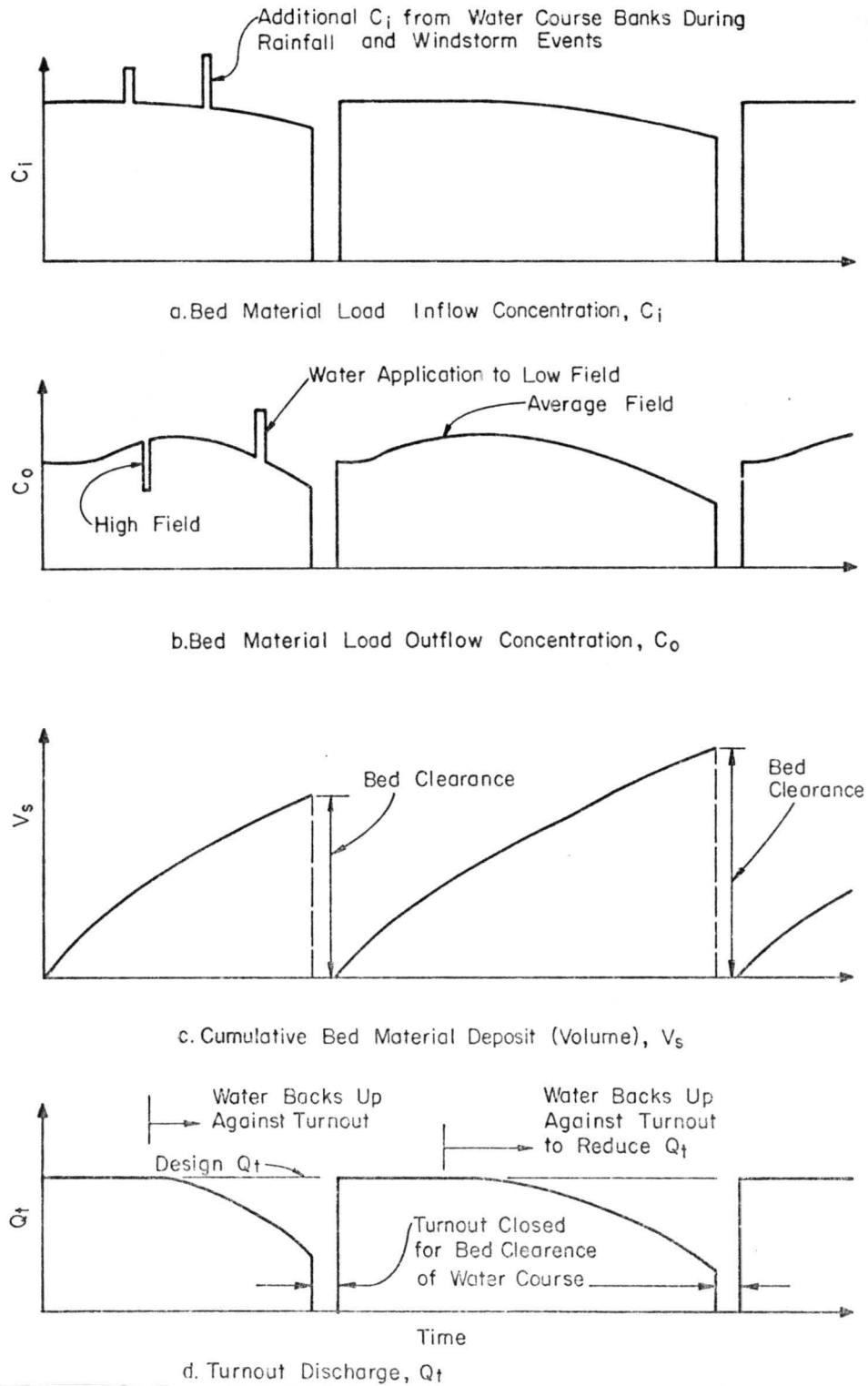

Figure 3. Schematic Reduction of Water Delivery by a Water Course Due to Aggradation.

## III. SUMMARY OF RESEARCH

The results reported herein pertain to four phases of research on the distribution of bed material load in irrigation canal systems:

1. Sediment distribution in an irrigation canal system to achieve system equilibrium.
2. Laboratory model studies of sediment withdrawal in turnouts.
3. Numerical simulation of sediment withdrawal in turnouts.
4. Sediment transport characteristics of watercourse channels.

Sediment Distribution in Irrigation Canal Systems

This phase of the study relates to the investigation of bed material load in irrigation diversions at turnouts, so that the system is in sediment discharge equilibrium. The main objective of this phase was to determine the limits on the bed material load concentration in individual irrigation diversions from a canal system.

This study was based on a computer simulated canal network with a 5,000 cfs head discharge. The layout of the system is shown in Fig. 4. The criteria for simulation and the system characteristics are given in Tables 1 and 2. The variation of discharge and aggregate length of channels in the system are shown in Fig. 5 as a function of distance from the headworks. The simulation procedure and analyses of sediment routing in the system have been described elsewhere (3, 4). Specifically, the simulated network was studied to answer the following questions:

1. For a given bed material load inflow in a canal system, what are the desirable criteria for sediment withdrawal by

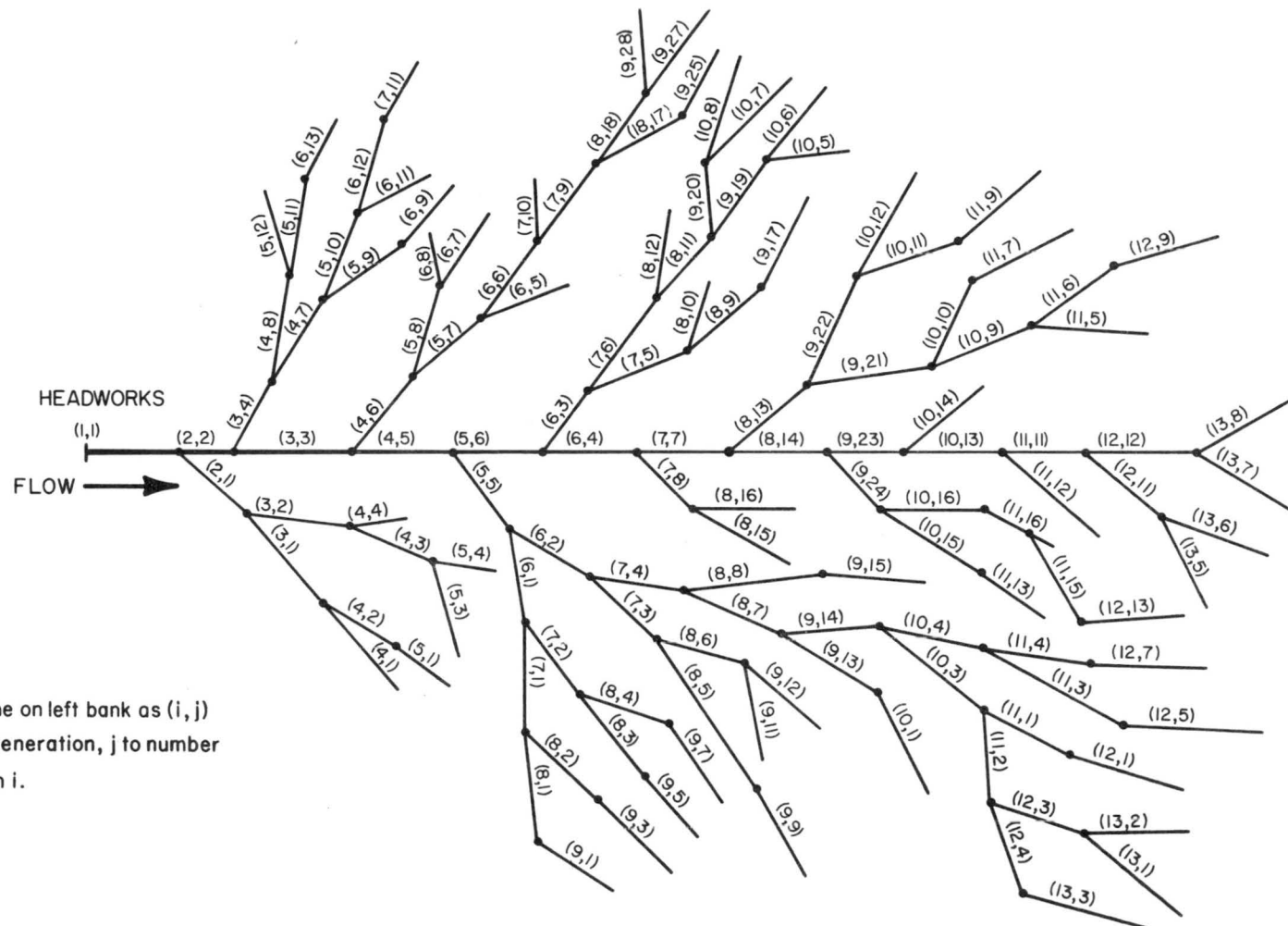

1. Channel name on left bank as (i, j)  
 2. i refers to generation, j to number of channel in i.

Figure 4. Simulated Irrigation Canal System with 5,000 cfs Discharge at Headworks.

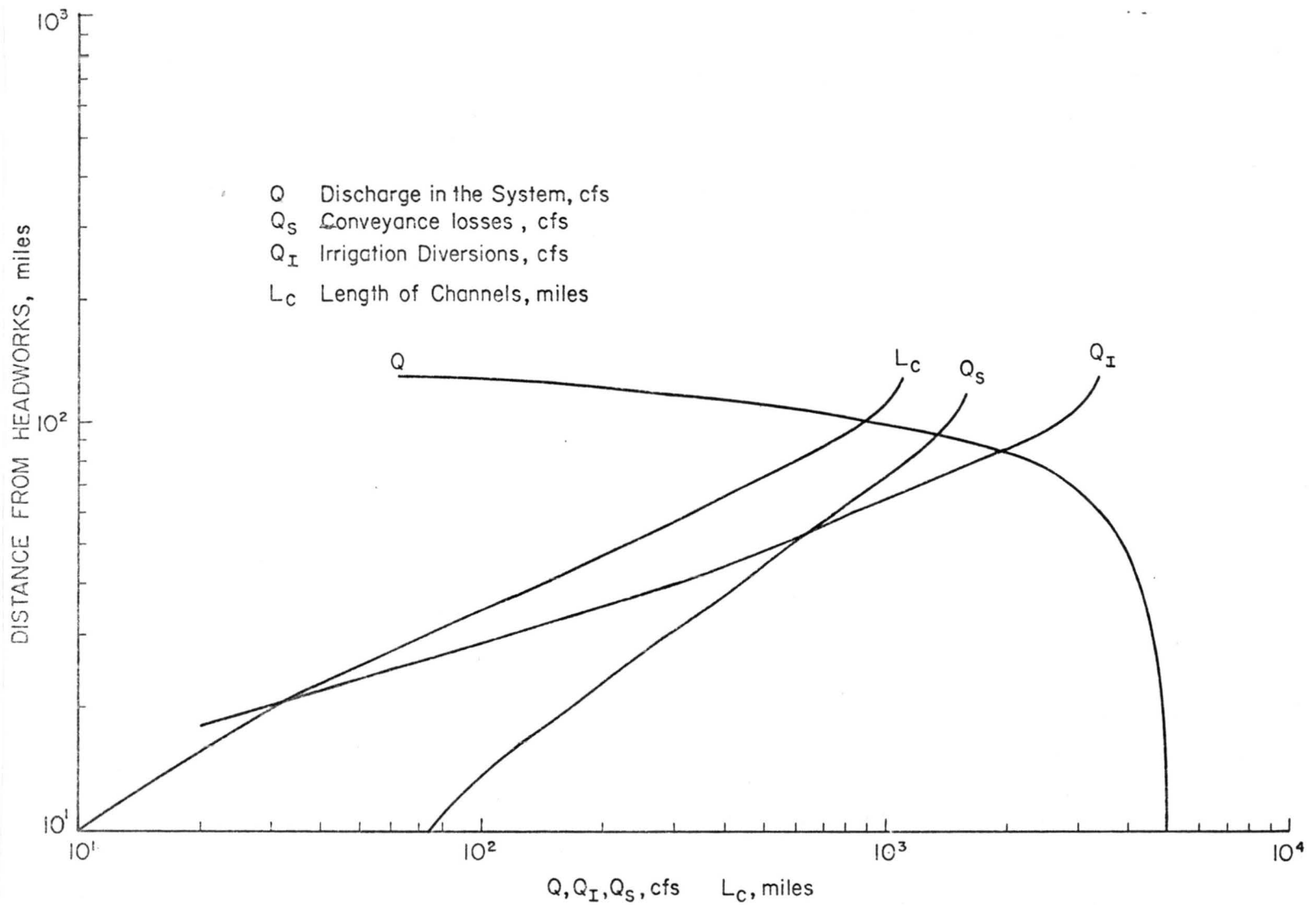

Figure 5. Discharge and Channel Length Variation with Distance from Headworks in the Simulated System.



TABLE 1

CRITERIA USED FOR SIMULATION OF IRRIGATION  
CANAL NETWORK SHOWN IN FIG. 4

|  |   |
|--|---|
| 1. Discharge at system headworks:                            | 5,000 cfs   |
| 2. Conveyance losses:  | 8 cfs per million square feet of wetted channel perimeter, constant throughout the system   |
| 3. Rate of Irrigation Diversion:                             |   |
| Canal Discharge, cfs:  | Rate of Irrigation Diversion,<br>cfs per mile of channel length   |
| > 2,500  | 0.0   |
| 1,200 to 2,500   | 1.0   |
| 500 to 1,200   | 2.0   |
| 50 to 500  | 3.0   |
| 10 to 50   | 4.0   |
| 4. Channel Bifurcation:                                      | Every 10 miles with random discharge distribution between branches.   |
| 5. Minimum Canal Capacity at a canal headworks:              | 10.0 cfs  |
| 6. Bed Material Size Variation along the system:             | Exponential reduction as  |
|  | $D_{50_l} = D_{50_o} e^{-\alpha L}$   |
| 7. Bed Material Load Distribution at Bifurcation Structures: | As required without any limitation.   |
| 8. Channel Design  | Regime channel sections with appropriate modification to transport required bed material load subject to channel stability condition. |
| 9. Channel Bed Material                                      | $D_{50} = 0.25 \text{ mm}$  |
| Size at Headworks:   | Gradation, $\sigma = 1.30$  |

TABLE 2

CHARACTERISTICS OF THE SIMULATED NETWORK  
(EXCLUDING FARM WATER COURSES)

|   |   |                                     |
|---|---|-------------------------------------|
| Discharge at headworks                              | = | 5,000 cfs                           |
| Length of channels                                  | = | 1,100 miles                         |
| Seepage loss  | = | 1,612 cfs                           |
| Irrigation diversions at<br>turnouts                | = | 3,388 cfs                           |
| Irrigation area                                     | = | 1.31 million acres                  |
| Gross Commanded Area (GCA)                          | = | 1.51 million acres                  |
| Irrigation channel density                          | = | 0.47 miles/mile <sup>2</sup> of GCA |
| Seepage loss as percent of<br>system head discharge | = | 32.2                                |

irrigation diversions so that the sediment problem is minimized in the system including the farm watercourses?

2. For the criteria developed in question 1, is it possible to design stable alluvial channel sections in the system?
3. If the answer to question 2 is negative, what modifications of criteria developed in question 1 are necessary to achieve stable alluvial channel sections?
4. What are the probable limits on the bed material load withdrawal in turnout diversions if the conditions imposed by the inquiry into questions 1, 2 and 3 are fulfilled?

The results of the network study are the following:

- 1.1 Methods of sediment control at canal headworks cannot completely eliminate the sediment load from low head diversions on sandbed channels. In large systems, sediment excluders or ejectors at the headworks are the most effective methods of reducing sediment entry to the canal system. However, even small bed material concentrations remaining in a system can accumulate over time to substantial magnitudes. The distribution of bed material load remaining in the system should be planned properly.
- 1.2 The capacity of an irrigated area within a system to absorb bed material load is determined by two factors. One, the texture of the soil\*, and two, the capacity of the watercourse, from the

---

\*The soil texture in turn has probably been determined to a large extent by sediment distribution. As indicated earlier sediment accumulates in many irrigation systems at about .04 inches per year. Consequently, soils in irrigation systems 80 years old will often have about 3 inches of canal sediment as their surface component. Whether these surface soils are medium or fine textured will depend largely on the size range of particles in the canal and the degree to which the coarser fractions settled out in the small watercourses leading to the farms.

turnout to the farm, to transmit the bed material load. The transport capacity of the watercourse channel depends on the size of the bed material, turnout discharge and the energy gradient available from the distributary channel to the farm. Some farms in a system will be limited in their sediment absorbing capacity, due to the preceding limitations, and they can be apportioned a smaller share of the bed material concentration. All other irrigation diversions in the system should receive equal bed material concentrations. Keeping these criteria in view, the irrigation farms or turnouts may be allotted sediment load according to a weight factor based on the capacity of a field or fields on a turnout.

2.1 The bed material transporting capacity of stable alluvial channels is generally limited to small values. However, within these limits it is possible to design a sandbed alluvial channel for a specified bed material load. The desirable condition for the sediment distribution within a system is to have bed material loads in all the channels at the same relative level with respect to their maximum transport capacity consistent with the alluvial channel stability.

2.2 In the design of stable channels, some other considerations must also be observed. These are:

- (a) In a bifurcating system of stable channels, the total bed material load transport capacity reduces as the discharge is split into smaller channels (reference (4), pp. 7-8). In an irrigation canal system, this effect is accentuated because the total waterflow in the system reduces in the

downstream direction due to seepage and evaporation losses and irrigation diversions (see Fig. 3).

- (b) The bed material size in an irrigation network also reduces in the direction of flow. Since smaller particles are carried more easily by the flow this size reduction compensates for the reduction of transport capacity in (a) to some extent. (See references (3) and (4) for detailed discussion.) The bed material size reduction in the direction of flow should be adequately considered in a study of sediment load distribution in a system.

- 2.3 A common misunderstanding in the design of stable channels based on Lacey's regime equations is that the values of regime coefficients or silt factors be maintained constant in a system. The writer refers to such a system as a "system-with-regime similarity" (3). Analysis of the simulated system shows that, in general, it is not possible to satisfy the criteria of para. 1.2 in a system-with-regime similarity (3).
- 2.4 As a result of the considerations 2.2(a) and 2.2(b), the analysis of the simulated system shows that in most cases the alluvial channel stability is improved if the distribution of bed material concentration in irrigation diversions given in para. 1.2 is further modified as indicated below.
- 3.1 In general, the sediment problem in conveyance channels is reduced if:
- (a) A system of weight factors is introduced that allocates smaller bed material load concentrations to irrigation

diversions from smaller channels in the system. In the simulated system (ref. (4)) the following system of weight factors was determined by trial and error:

| <u>Discharge at<br/>channel head<br/>Q(i,j), cfs</u> | <u>Weight factor W(i,j) to<br/>apportion bed material<br/>concentration in the irriga-<br/>tion diversions from the<br/>channel CH(i,j)</u> |
|--|---|
| > 200  | 1.00  |
| 100 to 200   | 0.90  |
| 40 to 100  | 0.75  |
| 20 to 40   | 0.60  |
| > 20   | 0.50  |

(b) If bed clearance in the channels is carried out to achieve sediment discharge equilibrium, it should be done in the middle and lower reaches of the system where the sediment transport capacity is smaller.

4.1 For an irrigation canal network that has a net bed material load concentration,  $C(1,1)$  entering the system and a total seepage loss of  $s$  percent, the average bed material load concentration  $\bar{C}_I$  (ppm) in the irrigation diversions through the turnouts is

$$\bar{C}_I = \frac{C(1,1)}{\left(1 - \frac{s}{100}\right)} \quad (1)$$

For  $s = 32.2$  percent,  $\bar{C}_I = 1.47 C(1,1)$

4.2 For a priori distribution of bed material load among irrigated units and with various methods of sediment disposal available in the system, the distribution of sediment in the channels and their irrigation diversions can be calculated as follows:

Let the irrigation diversions  $Q_I(i,j)$  from channel  $CH(i,j)$  draw bed material concentrations  $C_I(i,j)$  in proportion to some

non-negative weighting factor  $W(i,j)$ . Also for  $CH(i,j)$  let  $Q_s(i,j)$  = seepage loss in cfs,  $Q_b(i,j)$  = average loss in cfs due to accidents and escapages,  $C_b(i,j)$  = bed material concentration in  $Q_b(i,j)$  in ppm and  $G_c(i,j)$  = average quantity of bed material removed by bed clearance in lbs per second. Then the total discharge  $Q(i,j)$  in cfs, bed material load  $G(i,j)$  in lbs per second and its concentration  $C(i,j)$  in ppm at the head of  $CH(i,j)$  are given by

$$Q(i,j) = \sum_{k,l \in N} \{Q_I(k,l) + Q_s(k,l) + Q_b(k,l)\} \quad (2)$$

$$G(i,j) = \sum_{k,l \in N} \{Q_I(k,l) \cdot C_I(k,l) + Q_b(k,l) \cdot C_b(k,l)\} 62.5 \times 10^{-6} \\ + \sum_{k,l \in N} G_c(k,l) \quad (3)$$

and

$$C(i,j) = \frac{G(i,j) \cdot 10^{+6}}{62.5 Q(i,j)}, \quad (4)$$

where the symbol  $k,l \in N$  indicates that the summation for  $k$  and  $l$  is over the subset  $N$  of the channels in the system that includes all the channels supplied by and including  $CH(i,j)$ .

For the total system:

Irrigation discharge,

$$TQ_I = \sum_{\substack{i=1,n \\ j=1,m(i)}} Q_I(i,j) = Q(1,1) - \sum_{\substack{i=1,n \\ j=1,m(i)}} \{Q_s(i,j) + Q_b(i,j)\} \\ = Q(1,1) \left(1 - \frac{S}{100}\right), \quad (5)$$

weighted irrigation discharge,

$$WQ_I = \sum_{\substack{i=1,n \\ j=1,m(i)}} Q_I(i,j) \cdot W(i,j),$$

bed material load diverted with  $TQ_I$  ,

$$\begin{aligned} TG_I &= G(1,1) - \sum_{\substack{i=1,n \\ j=1,m(i)}} Q_b(i,j) \cdot C_b(i,j) 62.5 \times 10^{-6} - \sum_{\substack{i=1,n \\ j=1,m(i)}} G_c(i,j) \\ &= G(1,1) \left(1 - \frac{g}{100}\right) , \end{aligned} \quad (6)$$

where  $n$  is the total number of channel generations in the system and  $m(i)$  is the total number of channels in generation  $i$  (refer Fig. 4)

For individual channel segments,

$$\begin{aligned} C_I(i,j) &= C(1,1) \cdot \frac{\left(1 - \frac{g}{100}\right)}{\left(1 - \frac{s}{100}\right)} \cdot \frac{TQ_I}{WQ_I} \cdot W(i,j) \\ &= C(1,1) \left(1 - \frac{g}{100}\right) \frac{Q(1,1) W(i,j)}{WQ_I} \end{aligned} \quad (7)$$

4.3 Definition of the following parameters is helpful in studying the distribution of bed material concentration in the channels,  $C(i,j)$ , and that in the irrigation diversions,  $C_I(i,j)$ , in a system.

- (1) The ratio of the bed material concentration in  $CH(i,j)$  to that at the head of the system,

$$C_r(i,j) = \frac{C(i,j)}{C(1,1)}$$

- (2) The ratio of bed material concentration in irrigation supplies from  $CH(i,j)$  to  $C(1,1)$  ,

$$C_{I_r}(i,j) = \frac{C_I(i,j)}{C(1,1)}$$

- (3) The ratio of the bed material concentration in the irrigation supplies from  $CH(i,j)$  to the concentration in the channel  $C(i,j)$ ,



$$C_{\text{rat}}(i,j) = C_I(i,j)/C(i,j) .$$

The distribution of  $C_r$  within the system denotes the relative sediment transport capacity required for various channels in the system. The distribution of  $C_{I_r}$  denotes the departure of  $C_I$  in various channels from the average value of  $C_I$  in the system with  $g = 0$ . Parameter  $C_{\text{rat}}$  is relevant in designing the farm turnouts in a channel segment. The range of values of these parameters in the simulated system is shown in Table 3 for three contiguous channels A, B and C. It is seen from columns 2 in Table 3 that if the weight factors given in para. 3.1 are used

$$1.00 \leq C_r \leq 1.22$$

$$1.15 \leq C_{I_r} \leq 1.91$$

$$1.15 \leq C_{\text{rat}} \leq 1.86$$

That is, for  $G_c = 0$ ,  $Q_b = 0$  and a total seepage loss of 32.2 percent while  $\bar{C}_I = 1.47 C(1,1)$ , the turnouts on the system may have to be designed to withdraw 1.15 to 1.86 times the bed material concentration in the distributary channels to achieve sediment discharge equilibrium in the system.

#### Laboratory Model Studies of Sediment Withdrawal in Turnouts

The laboratory study of sediment withdrawal in turnouts was conducted in a 102 ft by 8 ft by 3.3 ft deep recirculating sandbed concrete flume. A 4 inch square turnout was mounted in the wall of the flume about 12 ft upstream of the tail baffle. The flow through the turnout was pumped back into the tail box of the flume. The discharge in the flume was measured by a venturi meter in the return

TABLE 3

VARIATION OF THE SEDIMENT LOAD DISTRIBUTION PARAMETERS  
IN THE SIMULATED SYSTEM

| CHANNEL<br>(i,j) | DISCHARGE AT<br>HEAD cfs<br>Q(i,j) | $C_r = \frac{C(i,j)}{C(1,1)}$ |      | $C_{I_r} = \frac{C_I(i,j)}{C(1,1)}$ |      | $C_{rat} = \frac{C_I(i,j)}{C(i,j)}$ |      |
|------------------|------------------------------------|-------------------------------|------|-------------------------------------|------|-------------------------------------|------|
|                  |                                    | 1*                            | 2*   | 1*                                  | 2*   | 1*                                  | 2*   |
| CHANNEL A        |                                    |                               |      |                                     |      |                                     |      |
| 1,1              | 5,000                              | 1.00                          | 1.00 | 0.00                                | 0.00 | 0.00                                | 0.00 |
| 2,2              | 4,590                              | 1.01                          | 1.01 | 0.00                                | 0.00 | 0.00                                | 0.00 |
| 3,3              | 4,090                              | 1.01                          | 1.01 | 0.00                                | 0.00 | 0.00                                | 0.00 |
| 4,5              | 3,530                              | 1.02                          | 1.02 | 0.00                                | 0.00 | 0.00                                | 0.00 |
| 5,6              | 1,940                              | 1.04                          | 1.04 | 1.47                                | 1.91 | 1.42                                | 1.83 |
| 6,4              | 1,370                              | 1.05                          | 1.06 | 1.47                                | 1.91 | 1.40                                | 1.81 |
| 7,7              | 1,230                              | 1.07                          | 1.08 | 1.47                                | 1.91 | 1.38                                | 1.76 |
| 8,14             | 743                                | 1.09                          | 1.10 | 1.47                                | 1.91 | 1.36                                | 1.74 |
| 9,23             | 446                                | 1.11                          | 1.13 | 1.47                                | 1.91 | 1.34                                | 1.69 |
| 10,13            | 357                                | 1.13                          | 1.14 | 1.47                                | 1.91 | 1.31                                | 1.66 |
| 11,11            | 271                                | 1.15                          | 1.17 | 1.47                                | 1.91 | 1.28                                | 1.63 |
| 12,12            | 117                                | 1.20                          | 1.16 | 1.47                                | 1.72 | 1.23                                | 1.48 |
| 13,7             | 42                                 | 1.26                          | 1.22 | 1.47                                | 1.43 | 1.17                                | 1.17 |
| CHANNEL B        |                                    |                               |      |                                     |      |                                     |      |
| 4,6              | 497                                | 1.10                          | 1.10 | 1.47                                | 1.91 | 1.35                                | 1.74 |
| 5,7              | 352                                | 1.11                          | 1.10 | 1.47                                | 1.91 | 1.33                                | 1.74 |
| 6,6              | 265                                | 1.13                          | 1.10 | 1.47                                | 1.91 | 1.31                                | 1.73 |
| 7,9              | 204                                | 1.16                          | 1.10 | 1.47                                | 1.91 | 1.27                                | 1.74 |
| 8,18             | 96                                 | 1.21                          | 1.02 | 1.47                                | 1.43 | 1.22                                | 1.39 |
| 9,27             | 32                                 | 1.29                          | 1.00 | 1.47                                | 1.15 | 1.15                                | 1.15 |
| CHANNEL C        |                                    |                               |      |                                     |      |                                     |      |
| 5,5              | 1,530                              | 1.04                          | 1.03 | 1.47                                | 1.91 | 1.42                                | 1.84 |
| 6,2              | 1,060                              | 1.05                          | 1.04 | 1.47                                | 1.91 | 1.41                                | 1.83 |
| 7,4              | 756                                | 1.05                          | 1.02 | 1.47                                | 1.91 | 1.40                                | 1.86 |
| 8,7              | 636                                | 1.07                          | 1.04 | 1.47                                | 1.91 | 1.37                                | 1.83 |
| 9,14             | 514                                | 1.11                          | 1.06 | 1.47                                | 1.91 | 1.34                                | 1.80 |
| 10,3             | 320                                | 1.13                          | 1.08 | 1.47                                | 1.91 | 1.31                                | 1.78 |
| 11,2             | 195                                | 1.16                          | 1.06 | 1.47                                | 1.72 | 1.27                                | 1.61 |
| 12,3             | 99                                 | 1.21                          | 1.02 | 1.47                                | 1.43 | 1.22                                | 1.40 |
| 13,1             | 31                                 | 1.29                          | 1.00 | 1.47                                | 1.15 | 1.15                                | 1.15 |

\*1.  $W(i,j) \equiv 1$  in the system.

\*2.  $W(i,j)$  as given in para. 3.1. (page 21).

channel and the total bed material load in the flume and turnout flows was measured by obtaining periodic samples from the return pipelines. The schematic of the laboratory arrangement is shown in Figures 6 and 7. The sand used in the flume had a  $D_{50} = 0.19$  mm and a gradation  $\sigma$  of 1.30.

Essentially, the laboratory runs were made in two series: 1. to establish the requirements for equilibrium flows in the flume-turnout system, and 2. to study the sediment withdrawal phenomenon in turnouts with 2 different turnout elevations under equilibrium flow conditions. The equipment, experimental procedure and the data obtained in the laboratory study have been described in references (6) and (7). In all, 126 equilibrium runs were made. The range of variables covered in the study is given in Table 4.

The exploratory runs established the time requirements for the achievement of equilibrium flow in the flume-turnout system. These results were used to design the operation sequence of the equilibrium runs.

The turnouts in distributary channels also develop a scour pit due to the curvature of flow induced by the diversion and the removal of bed material load. For the turnout discharge equal to or greater than the discharge intensity in the distributary channel, the dimensions of the scour pits can be substantial. This condition prevails in smaller distributary channels ( $Q \leq 50$  cfs). The longitudinal profiles of such channels are then affected by the scour pit dimensions. For these reasons, the scour pit geometry was also studied in the flume.

The results obtained from the laboratory study are applicable to field channels and turnouts in the range of variables studied in the

TABLE 4

RANGE OF VARIABLES COVERED IN  
THE LABORATORY STUDY ON TURNOUTS

(Equilibrium Runs)

Flume:

|  |                            |
|--|----------------------------|
| Bed Material                                     | $D_{50} = 0.19 \text{ mm}$ |
|  | $\sigma = 1.30$            |
| Discharge intensity, $q_f$<br>(cfs per ft width) | 1.20 to 2.40               |
| Depth of flow, $d_f$ (ft)                        | 0.89 to 1.89               |
| Bed material concentration,<br>$C_f$ (ppm)       | 1 to 1,050                 |
| Froude number of flow, $F$                       | 0.12 to 0.40               |

Turnout:

|   |                                       |
|---|---------------------------------------|
| Size and geometry                         | 4 in, square with<br>bell mouth entry |
| Discharge, $Q_t$ (cfs)                    | 0.23 to 1.70                          |
| Bed material concentration<br>$C_t$ (ppm) | 3 to 3,860                            |

Ratios:

|   |                 |
|---|-----------------|
| Discharge ratio, $q_r = \frac{Q_t}{q_f}$                    | 0.12 to 0.94 ft |
| Setting, $Y_t$  | 0.60 to 0.96    |
| Bed material concentration<br>ratio $C_r = \frac{C_t}{C_f}$ | 1.5 to 7.9      |

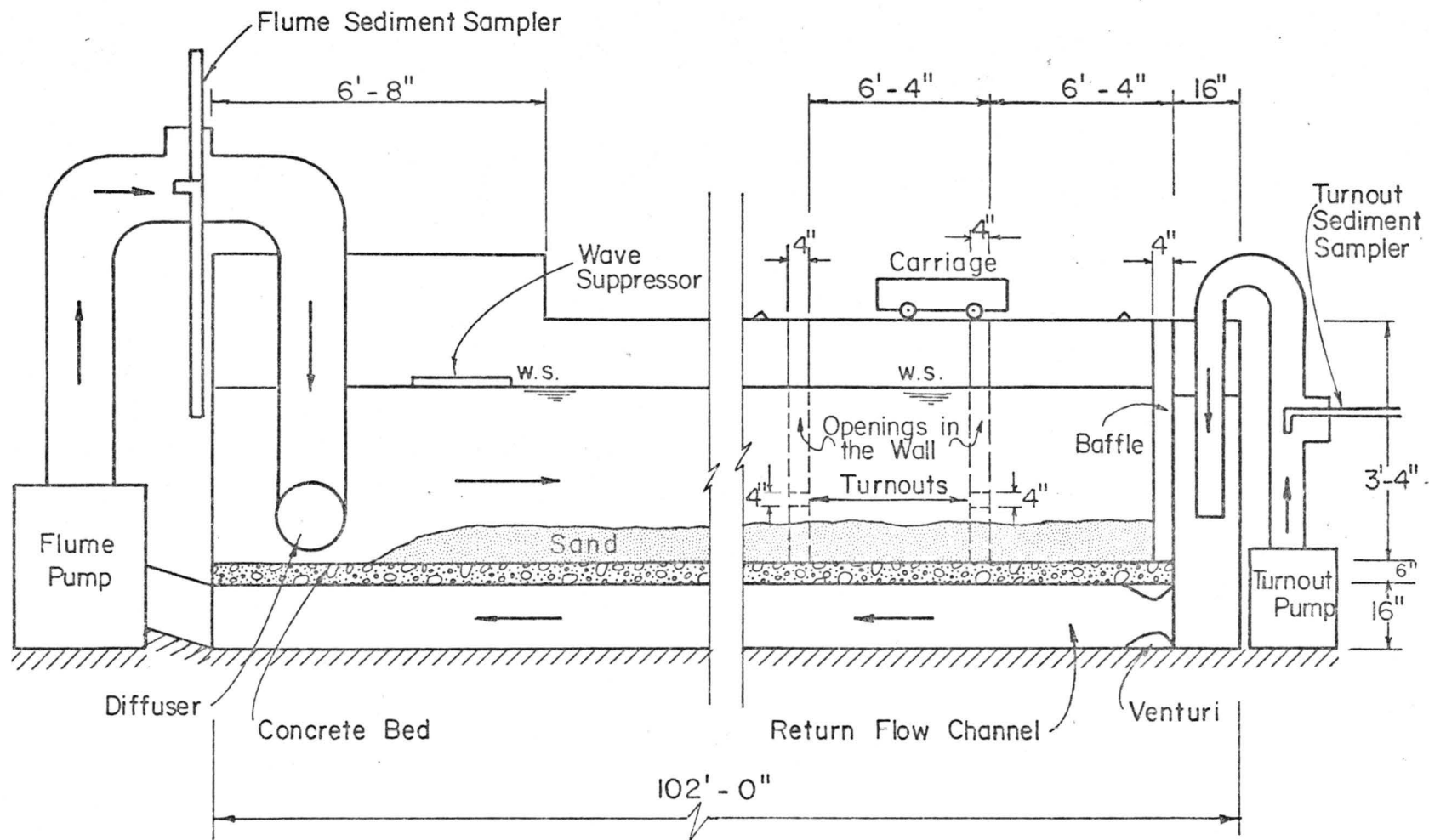

Figure 6. Schematic Arrangement of Laboratory Flume.

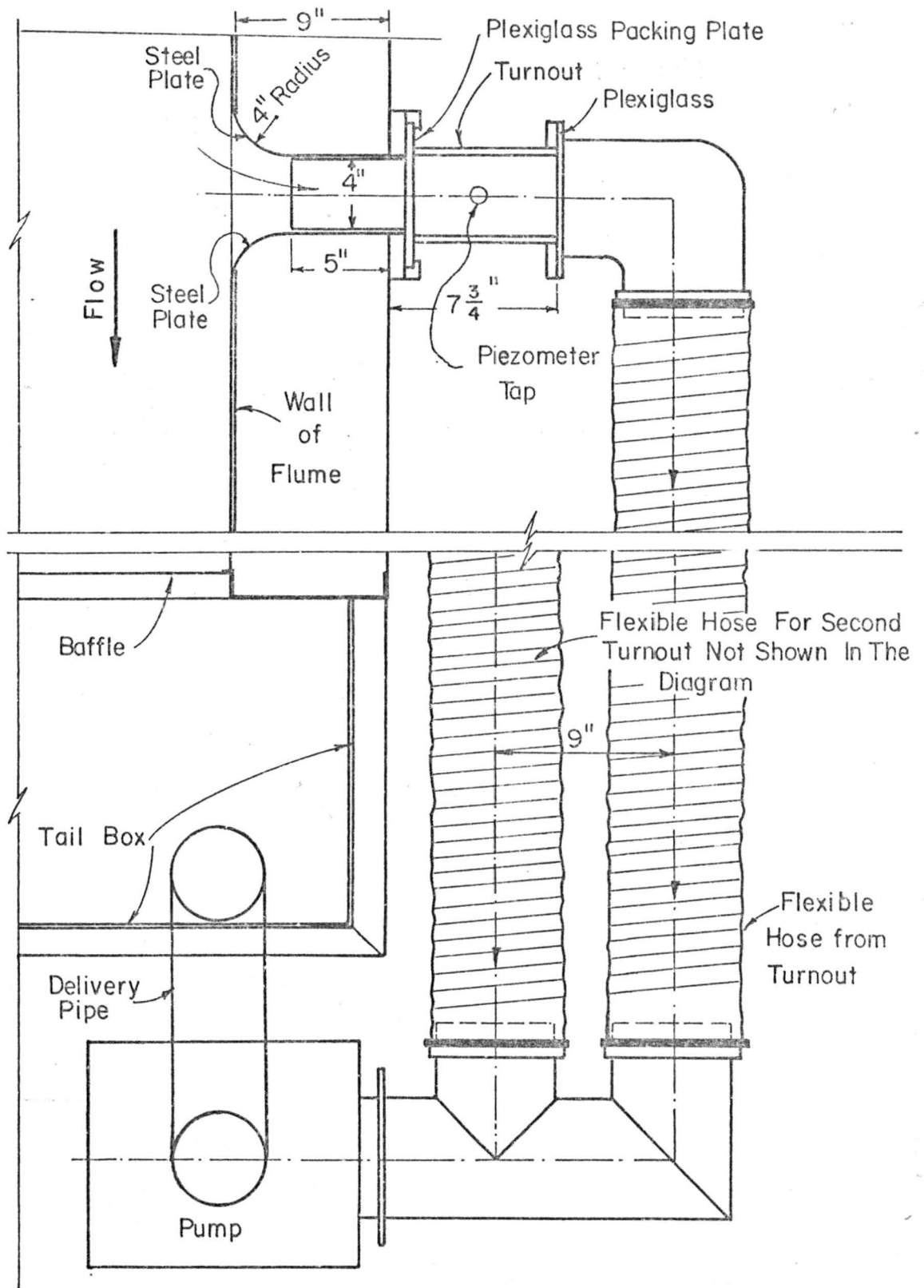

Figure 7. Layout of Turnout in Laboratory Flume (plan view).

laboratory (see Table 4). The bed material load in most of the laboratory runs moved as contact load and the bed forms ranged from ripples (in most of the runs) to dunes. The conclusions of the laboratory study are:

1. The sediment concentration passing through the turnout is highly fluctuating in time. These fluctuations are related to the general stochastic nature of sediment transport phenomenon and also to the passage of bed forms (ripples or dunes) in front of the turnout. A high dune passing in front of the turnout will generate many times the average bed material concentration in the turnout flow. Representative averages of  $C_t$  can therefore be obtained from observations extending over time required for the passage of one or more bed forms in front of the turnout.
2. The bed material concentration in the turnout flow,  $C_t$  is mainly related to the concentration in the flume,  $C_f$ . It is not significantly affected by the discharge ratio of turnout to the flume. Statistically, the  $C_t - C_f$  relation is found as:

$$C_t = 4.1 C_f^{0.96} Y_t^{0.32} \quad (8)$$

In Eq. 8,  $C_t$  and  $C_f$  are the bed material load concentrations in ppm in the flow through the turnout and in the flume flow approaching the turnout, respectively, and  $Y_t$  is the setting of the turnout (see Fig. 8 for definition). This equation shows that within the range

$$q_f = \frac{Q_f}{W} ;$$

$$V_r = \frac{V_t}{V_f}$$

$$Y_t = \left(1 - \frac{d_c}{d_f}\right) ;$$

$$q_r = \frac{Q_t}{q_f}$$

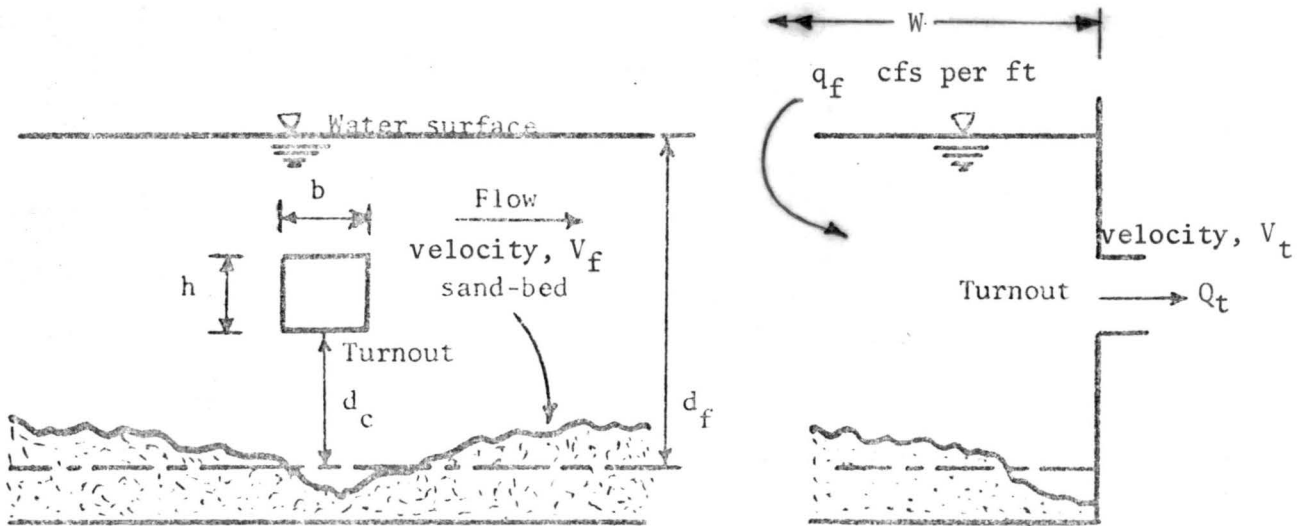

Figure 8. Definition Sketch of Turnout Variables.



of laboratory data,  $C_t$  increases as  $C_f$  increases.  $C_t$  also increases as the turnout is set closer to the channel bed. As  $C_f$  appears to be the primary variable determining  $C_t$ , the effect of other variables such as temperature, viscosity, shear velocity, discharge ratio, etc., was not statistically significant.

3. The scour pit geometry in the flume was almost similar from run to run, with the deepest scour depth occurring close to the turnout wall. Maximum depth of the scour pit generally increased with increasing value of  $q_r (= Q_t/q_f)$ , where  $Q_t$  and  $q_f$  are the total discharge in the turnout and the discharge per unit width in the flume, respectively. The dimensionless average depth of scour close to the turnout was measured by  $d_r (= \frac{d_s}{d_f})$ , where  $d_s$  is the average depth of scour below the mean sandbed level along a 9 foot line extending upstream and downstream of the turnout in the channel at 3 inches from the wall and  $d_f$  is the mean depth of flow in the flume. Parameter  $d_r$  was essentially found to be related to  $(q_r)^{0.40}$ . Statistically this relation was found as:

$$d_r = 0.32 q_r^{0.40} \quad (9)$$

On account of the fixed geometry of the turnout and the flume in this study, a more general expression for the scour pit dimensions could not be obtained.

4. The field situations of sediment conduction in farm turnout are characterized by the principal mode of

bed material transport, the ratio of the turnout throat velocity to the flow velocity in the channel, the bed form regime, the bed material size and gradation, turnout geometry, turnout setting, curvature of channel flow in plan view, etc. The preceding results of laboratory study are applicable to the following situations only.

|  |   |                       |
|--|---|-----------------------|
| i. Turnout dimension, $\frac{h}{d_f}$        | — | 0.22 to 0.33          |
| ii. Turnout setting, $Y_t$                   | — | 0.60 to 0.96          |
| iii. Bed material                            | — | medium to coarse sand |
| iv. Principal mode of bed material transport | — | as bed load           |
| v. Discharge ratio, $q_r = \frac{Q_t}{q_f}$  | — | 0.12 to 0.94 ft       |
| vi. Channel alignment                        | — | straight              |

#### Numerical Simulation of Sediment Withdrawal in Turnouts

The bed material transport in most field channels with fine to medium sandbeds mainly occurs as suspended load. In major distributary and conveyance channels in an irrigation network the ratios  $q_r$  and  $h/d_f$  for farm turnout are smaller than their range investigated in the laboratory study. A similitude analysis of the sediment withdrawal in turnout was made to investigate the possibility of extending the laboratory results to field size channels. This analysis was based on geometric similarity, the similarity of Froude number,  $F$  and of the dimensionless bed material concentration profile in the depth of flow (see appendix II and reference 6 for details of this analysis). The analysis showed that the laboratory results can be utilized for coarse bed material channels transporting the bed material load

essentially as bed load but cannot be extended to channels with fine-medium sandbed transporting large proportions of bed material load in suspension. It would have been necessary to extend the laboratory study to higher discharges, finer bed material, smaller turnout dimensions, etc. In view of the time and money limitations, the laboratory study was not extended for these conditions. However, a numerical model was developed that approximates the kinematics of the turnout flow. This model was used to study the sediment withdrawal characteristics of turnouts beyond the conditions covered in the laboratory study.

The numerical model assumes that the flow field due to the turnout can be represented by a distributed sink and superimposes this field on the equilibrium flow field of the sandbed channel. The computation of sediment withdrawal by the turnout is then carried out on the following assumptions: 1. equilibrium sediment concentration profiles exist in the channel flow upstream of the turnout for each size fraction of the bed material and these profiles are known a priori from one of the applicable methods of bed material load computation; 2. the bed material concentration in the parcel of flow entering the turnout is unaffected by the curvature of streamlines induced by the turnout. This approach is reasonably valid for smaller values of  $q_r$ ,  $\frac{h}{d_f}$  and for suspended load transport of fine to medium sands. Details of this model are given in Appendix I and similitude criteria for sediment withdrawal in turnouts based on the numerical model and sediment transport principles are given in Appendix II.

The numerical model was used to study the effect of turnout variables for some field size channels. The resistance and bed material transport

functions used in the simulation were those developed by the writer (1). The conclusions of these simulation studies as applicable to field turnouts are:

1. The primary turnout sediment withdrawal design parameters are  $C_{rat}$ ,  $D_{50r}$  and  $\sigma_r$ . These dimensionless parameters are the ratio of concentration, the median particle size and size gradation of the bed material load in the turnout flow to that in the distributary flow, respectively. Their numerical values are needed in the design of turnouts on distributary channels and in the design of farm watercourses. (see pp. 46 to 48 in Chapter IV).
2. For a given bed material mixture, different suspended load concentration profiles can be defined for different particle size fractions. Essentially, the shape and steepness of these concentration profiles is determined by the Rouse number,  $Z = \frac{w}{ku_*}$ , where  $w$  is fall velocity of the bed material size fraction,  $u_*$  is the shear velocity and  $k$  is von Karman's constant  $\approx 0.4$ . (Note if Einstein's bed load function is used, the value of  $u_*$  used in defining  $Z$  is that associated with grain roughness and not the total  $u_*$  at the boundary).
3. The flow field due to the turnout becomes independent of the size and geometry of the distributed sink (representing the turnout) farther away from the turnout. Therefore, parameters  $C_{rat}$ ,  $D_{50r}$  and  $\sigma_r$  are relatively independent of the size and geometry of the turnout.

4. For values of  $q_r$  ( $= Q_t/q_f$ ) between 0.2 and 0.5, ratios  $C_{rat}$ ,  $D_{50r}$  and  $\sigma_r$  are almost independent of  $q_r$ . This limit on  $q_r$  would vary for different  $Z$  values. This effect was however not investigated in this study.
5. Ratios  $D_{50r}$  and  $\sigma_r$  for a given field channel are primarily a function of the turnout setting,  $Y_t$ . These ratios increase rapidly in the beginning and then slowly as  $Y_t$  is increased. (Refer Fig. 11 for a particular example.)
6. Based on the numerical model (Appendix I), design curves for the parameters  $C_{rat}$ , etc., can be developed for a given channel. These curves can also be extended to other channels by the similitude criteria given in Appendix II. A particular numerical example is presented in Chapter IV to illustrate this method.

#### Sediment Transport Characteristics of Water Course Channels

The sediment discharge equilibrium of water course channels also requires that the bed material load inflow through the turnouts be equal to the bed material outflow to the fields plus the sediment removed by channel bed clearance. The effect of sediment discharge nonequilibrium in water courses is schematically represented in Fig. 3.

The hydraulics and sediment transport of watercourse channels is complicated if the only control at the end of a watercourse is the level of field under irrigation. In such a case, truly uniform flow is never attained in the total length of the watercourse. In long watercourses, the control for the upstream reaches may still lie on the bed, with the downstream reaches under a backwater (high field level) or a

drawdown (low field level) curve. Under a backwater curve, the sediment transport is reduced and the channel aggrades while under a drawdown curve the transport is increased and the channel degrades. Thus, the sediment transport also varies along the length of watercourse with the level of field under irrigation. The total sediment transport through the watercourse is then unsteady with different lengths of the channel alternately aggrading and degrading. An artificial control at the end of the watercourse can avoid this condition and may be usefully employed if the overall energy gradient from the distributary channel to the farm permits the additional head loss at the control.

The hydraulics of the watercourse channels is further complicated, as they are relatively narrow channels with larger proportion of bank area in their wetted perimeter. The bank roughness in watercourse channels can play a dominant role over the bed roughness if the banks are irregular or vegetated. The maintenance of watercourses is generally poor and the weed growth is more rampant than in larger alluvial canals. The total resistance to flow in watercourse channels is therefore largely determined by the condition of their banks. The effect of bank roughness on the total resistance to flow in watercourse channels has not been investigated. Such a study can be best made under field conditions. On the other hand, the resistance to flow due to the bed roughness of the watercourse is easy to estimate. The reason is that the scale of flow in watercourse channels is the same as in most laboratory studies conducted so far. A number of methods are available for the hydraulic design of watercourse scale channels. Any of these methods can be applied in practice, provided the effect of bank roughness is duly accounted for.

The unlined watercourse channels are also self-formed alluvial channels to some extent. Therefore, regime theory equations are sometimes used in their design. If this approach is used, consideration should be given to the difference in the shape of watercourse channels and larger distributary or conveyance channels. In larger alluvial channels, a trapezoidal cross section is a good approximation of the actual channel section, except in nonstraight reaches. The watercourse channels, on the other hand, are more elliptical in form. The hydraulic elements of elliptical channels are given in Appendix III for reference.

The bed material in a watercourse, is initially determined by the soil profile through which the watercourse is constructed. If the soil profile is finer in size than the incoming bed material load through the turnout or if the watercourse bed is reformed by aggradation during operation, then the bed material changes to reflect the size of the sediment load coming through the turnout. The relation between the incoming sediment size and the bed material that develops in a channel has not been investigated so far. However, the bed material size ultimately developing in a watercourse channel will be coarser than the incoming load due to the differential transport of sediment by particle sizes. Also the gradation of the bed material,  $\sigma$ , will be smaller than the gradation of the incoming load. There is no numerical guide to estimate the bed material that will develop in a watercourse except by some complicated numerical analyses (8). This probably would not be justified in view of the small size of the watercourse channel and the large number of these channels in a system. A field study can be carried out to develop empirical relations for this purpose.

The computation of bed material transport capacity of watercourse channels can also be based on the laboratory flume results for reasons of similarity of scale. Again because of the small size of the watercourse channels, in contrast with larger canals, use of more sophisticated computational procedures will not be warranted in practice. For most practical purposes it will be adequate to use some existing empirical relationships or others that can be easily developed by research under field conditions.

The watercourse channels, leading from the canals to the farms are the last link in the delivery of irrigation water. They have been largely neglected in the study of conveyance system, because of their small size. Field research on the hydraulic and sedimentation aspects of watercourse channels is urgently needed. Research on the watercourse channels was not conducted in this study. However, methods for the design of watercourse channels based on the adaptation of currently available techniques were developed. This adaptation is illustrated in Chapter IV.



## IV. APPLICATION OF RESULTS

The results of research reported herein and the concepts developed in this report can be applied in designing for a desired sediment distribution in an irrigation system. This use is illustrated by a numerical example pertaining to the simulated canal network.

Numerical Example

It is proposed to design the turnouts and water courses for irrigation diversions from Channel (11,11) of the simulated system (Fig. 4 and Table 3).

Given data:

Discharge at head of channel = 271 cfs

Discharge at tail of channel = 224 cfs

Irrigation diversions = 30 cfs

Conveyance losses = 17 cfs

Bed Material:  $D_{50} = 0.174$  mm  
 $\sigma = 1.35$

Bed material concentration

at head of the system = 94 ppm

Bed Material Load distribution Parameters:

Weight factors - as in para. 3.1 (page 21)

$C_r = 1.17$  (Table 3)

$C_{I_r} = 1.91$  (Table 3)

$C_{rat} = 1.63$  (Table 3)

1. Computations for the Design of Stable Alluvial Channel.

Bed Material Load Concentration

in the channel =  $94 \times 1.17 = 110$  ppm

Regime channel section with  $f_{vr} = 0.74$

and  $f_{sq} = 0.74$  (see reference 5))

Bed width,  $W = 34.9$  ft  
 Depth,  $d = 4.03$  ft  
 Average velocity,  $V = 1.82$  ft per second  
 Hydraulic gradient,  $S = 1.24 \times 10^{-4}$

For kinematic viscosity,  $\nu = 1.10 \times 10^{-5}$  ft<sup>2</sup> per sec,  
 the bed material load for the preceding section is computed by  
 the method of reference (1) as:

Bed material load concentration = 110 ppm with  
 $D_{50} = 0.083$  mm, and  $\sigma = 1.69$

## 2. Sediment Withdrawal Characteristics of Turnouts

The sediment withdrawal characteristics of the turnouts on channel (11,11) are computed next, with the help of the numerical method of Appendix I and the bed material load method of reference (1). The following turnout data are assumed for computational purposes.

Square orifice turnout 0.50 ft x 0.50 ft

Turnout setting,  $Y_t = 0.97, 0.85, 0.65$  and  $0.40$

Turnout discharge,  $Q_t = 3.5, 2.5$  and  $1.5$  cfs

First, the average velocity profile in channel (11,11) is determined from the channel data, as described for sandbed channels in reference (1). Using this velocity distribution in the channel and the flow fields due to distributed sinks representing the turnout setting and discharges, the method of Appendix I is applied. This yields the boundaries of undisturbed regions in the uniform channel flow that feed the turnouts for various  $Q_t$  and  $Y_t$ . These regions for the case of channel (11,11) are shown in Fig. 9. To obtain the bed material load

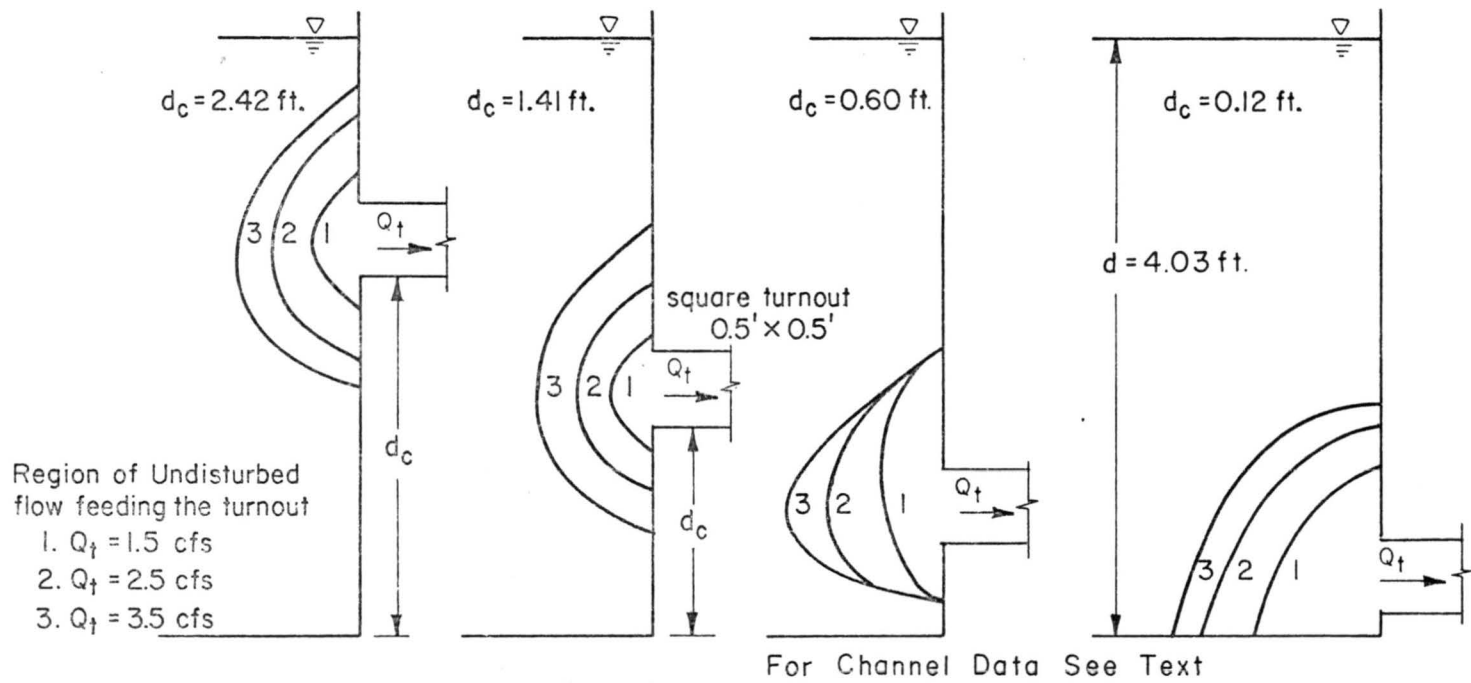

Figure 9. Regions of Undisturbed Channel Flow Feeding the Turnout for Different Turnout Settings and Discharges in Channel (11,11).

coming from these regions, the bed material load and discharge distribution along the vertical are required. These distributions are obtained from the average velocity profile already determined and the bed material concentration profile from the methods developed in reference (1). For the present computations, these distributions can be better represented as cumulative discharge  $Q_y$  and bed material load,  $G_y$  curves, where

$$Q_y = \int_0^y u_y dy ,$$

$$G_y = \int_0^y 62.5 \times 10^{-6} c_y u_y \cdot dy ,$$

$y$  is the vertical distance from the mean channel bed elevation to a point in the flow,  $u_y$  is the velocity given by the average velocity profile at  $y$  and  $c_y$  is the bed material concentration at  $y$  in ppm. The  $G_y$  curves vary for different bed material size fractions. The  $Q_y$  and  $G_y$  curves for 10 size fractions are shown for channel (11,11) in Fig. 10. The bed material load and discharge contained in the undisturbed flow regions of Fig. 9 are then determined by numerical integration of the curves in Fig. 10 over these regions. The integration computations for bed material load are made for different size fractions, so the size distribution of the bed material load coming from the undisturbed flow regions is also obtained. By the hypothesis of Appendix I, the integrated quantities ( $Q$  and  $G$ ), represent the discharge and bed material load passing through the turnout. The size distribution of the bed material load is also known. These results are presented in Fig. 11, as ratios  $C_{rat}$ ,  $D_{50r}$  and  $\sigma_r$  of the corresponding quantities for the bed material load withdrawn by the

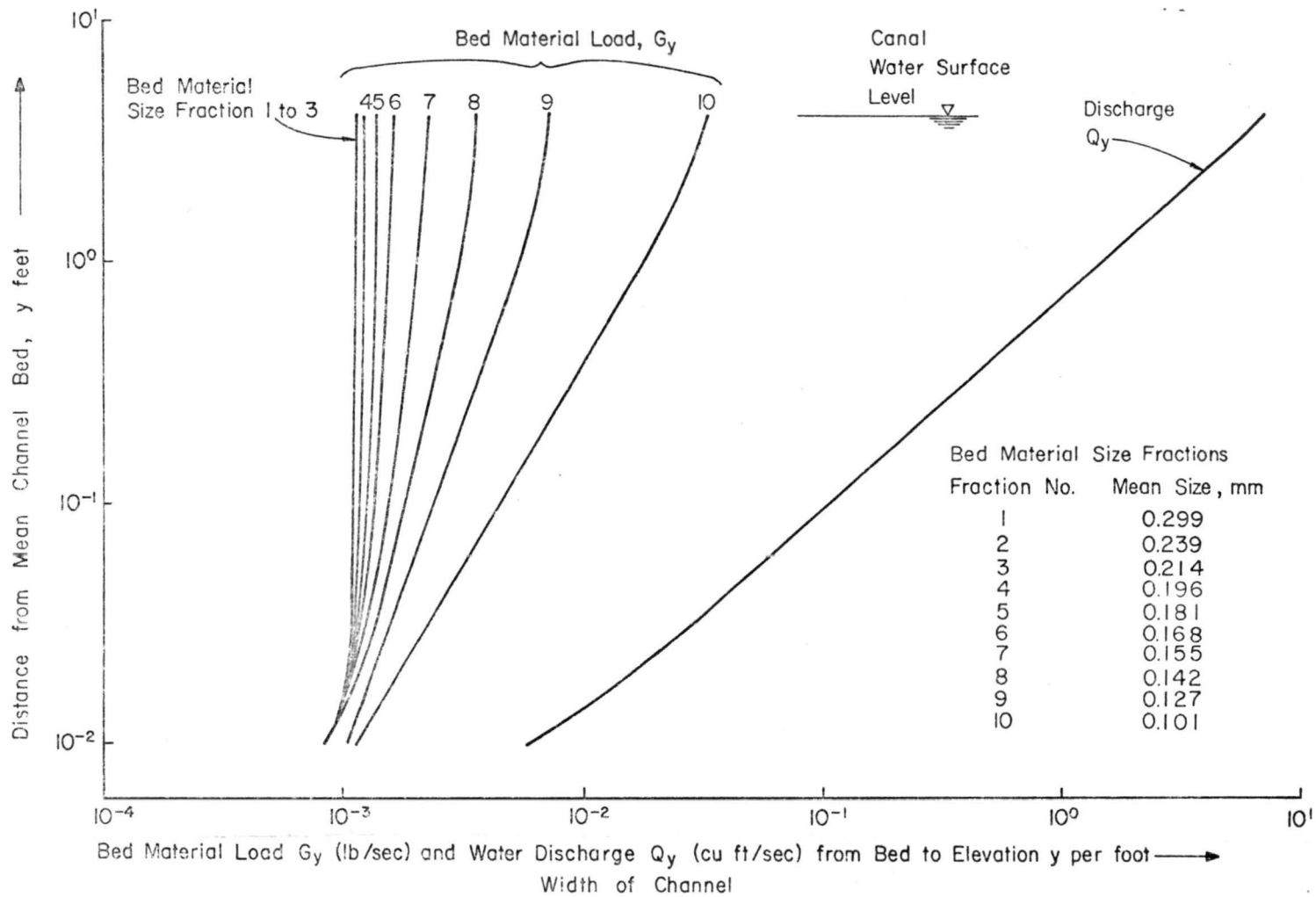

Figure 10. Cumulative Distribution of Water Discharge and Bed Material Load in Channel (11,11) Along Depth of Flow.

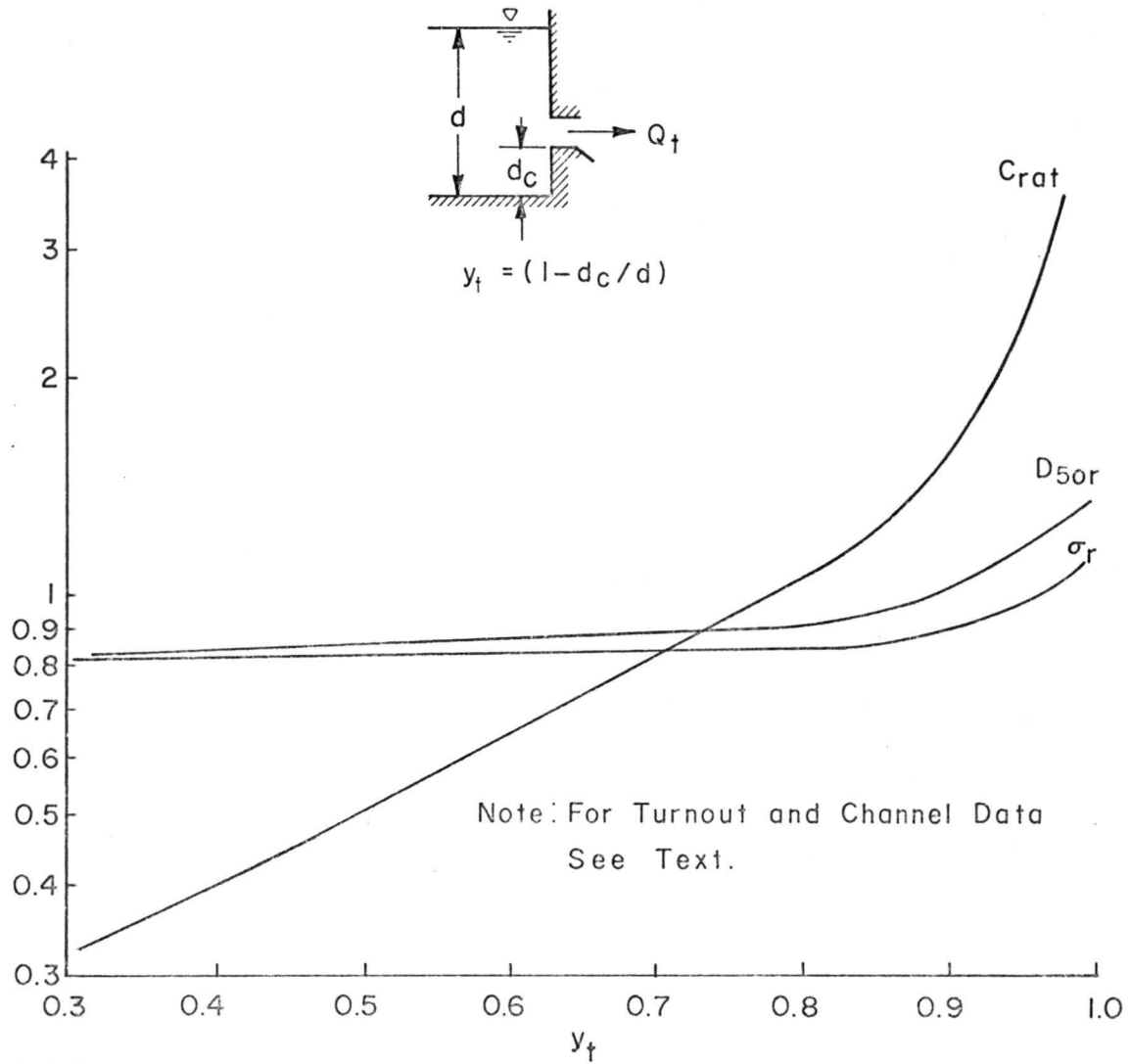

Figure 11. Variation of Bed Material Load Characteristics of Turnouts on Channel (11,11) With Turnout Setting  $y_t$ .

turnouts and that transported in the canal. These computations, also indicated that parameters  $C_{rat}$ ,  $D_{50r}$  and  $\sigma_r$  for channel (11,11) are relatively insensitive to the turnout discharge within the limits  $1 \text{ cfs} \leq Q_t \leq 3.5 \text{ cfs}$ .

### 3. Required Bed Material Load in Turnouts.

The average bed material concentration in the irrigation diversions from channel (11,11) has already been calculated for obtaining sediment discharge equilibrium in the system (see column 2 for  $C_{rat}$  in Table 3). The average value of  $C_{rat}$  for this channel is 1.63. For the sake of illustration, it is assumed that various turnouts on channel (11,11) are to be given unequal bed material load weight factors,  $w(m)$ ,  $m = 1, 2, \dots, 9$  as shown in Table 5. In practice, such unequal weightage for bed material load may be needed, if the water course channels leading from some turnouts to the farms cannot transport the load based on average  $C_{rat}$  of the channel or if the farms on some turnouts cannot accept the bed material load due to limitations of the soil texture. For given discharges of the turnouts, and the weight factors,  $w(m)$ , the required value of  $C_{rat}$  for individual turnouts are computed in Table 5. These computations are based on the assumption that the total sediment diversion with irrigation supplies from channel (11,11) is the same as required for sediment discharge equilibrium in the system.

### 4. Design of Turnouts.

For the given value of  $C_{rat}$ , the turnout setting  $Y_t$  and ratios  $D_{50r}$ ,  $\sigma_r$  can be obtained from the curves in Fig. 9.

TABLE 5

BED MATERIAL LOAD DISTRIBUTION  
AMONG TURNOUTS ON CHANNEL (11,11)

| Turnout<br>no.              | Discharge<br>$Q_t$<br>cfs | Weight Factor<br>$w$ | Bed Material Load<br>in Turnout Flow |                                     | Ratio<br>$C_{rat}$ |
|-----------------------------|---------------------------|----------------------|--------------------------------------|-------------------------------------|--------------------|
|                             |                           |                      | Concen-<br>tration,<br>$C_t$ ppm     | Trans-<br>port,<br>$G_t$ lb/<br>sec |                    |
| 1                           | 4.0                       | 1.0                  | 207                                  | 0.052                               | 1.88               |
| 2                           | 4.0                       | 1.0                  | 207                                  | 0.052                               | 1.88               |
| 3                           | 4.0                       | 0.9                  | 186                                  | 0.046                               | 1.69               |
| 4                           | 4.0                       | 0.9                  | 186                                  | 0.046                               | 1.69               |
| 5                           | 4.0                       | 0.8                  | 166                                  | 0.042                               | 1.50               |
| 6                           | 3.0                       | 0.8                  | 166                                  | 0.031                               | 1.50               |
| 7                           | 3.0                       | 0.75                 | 155                                  | 0.029                               | 1.40               |
| 8                           | 2.0                       | 0.75                 | 155                                  | 0.019                               | 1.40               |
| 9                           | 2.0                       | 0.75                 | 155                                  | 0.019                               | 1.40               |
| Total for<br>the<br>channel | 30.0                      |                      | 179                                  | 0.336                               | 1.63               |



For example, for turnout no. 3 with  $C_{rat} = 1.69$ :  $Y_t = 0.91$ ,  $D_{50r} = 1.05$  and  $\sigma_r = 0.91$ . The crest elevation of the turnout is

$$\begin{aligned} d_c &= (1 - Y_t) d \\ &= 0.09 \times 4.03 = 0.36 \text{ ft above the average} \\ &\quad \text{channel bed.} \end{aligned}$$

The size of the turnout can be determined from appropriate discharge formula. The dimensions and geometry of the turnout are not critical for the bed material load withdrawal characteristics.

The bed material load characteristics of irrigation withdrawal through turnout no. 3 are

$$\text{Concentration } C_t = 186 \text{ ppm}$$

$$\text{Median size } D_{50} = 0.083 \times 1.05 = 0.087 \text{ mm}$$

$$\text{Gradation } \sigma = 1.69 \times 0.91 = 1.54$$

##### 5. Water Course Bed Material.

As discussed on pages 38-39, the final bed material of the watercourse channel will be coarser than the incoming load through the turnout, if the initial soil material (through which the water course has been excavated) is finer than the incoming load or if the watercourse bed is reformed by aggradation. Assume that these conditions apply. Let the watercourse bed material have a median size  $D_{50} = 0.16$  mm and a gradation,  $\sigma = 1.31$ .

##### 6. Channel Geometry and Bed Material Transport in Water Course.

In general, it will be appropriate to obtain and use morphologic, hydraulic and bed material load functions for the

design of unlined watercourse channels, from similar field watercourses. In the following illustration, it is assumed that a stable elliptical channel section applies. Therefore, the sectional geometry and size of the watercourse channel can be designed by regime equations of stable alluvial channels. For this purpose the regime equations are presented as:

Equations for sectional geometry and size:

$$f_{vr} = \alpha_1 \sqrt{D_{50}} \quad (10)$$

$$V = \alpha_2 \sqrt{f_{vr}} \cdot R \quad (11)$$

$$P = \alpha_3 \sqrt{Q} \quad (12)$$

Equations for resistance function

$$f_{sq} = \alpha_4 \cdot f_{vr} \quad (13)$$

$$S = \frac{5.47 \times 10^{-4} \cdot f_{sq}^{5/3}}{Q^{1/6}} \quad (14)$$

In Eqs. (10) to (14),  $\alpha_1$ ,  $\alpha_2$ ,  $\alpha_3$ ,  $\alpha_4$ , are called the regime coefficients,  $f$  is Lacey's silt factor,  $D_{50}$  is the median bed material size,  $R$  is the hydraulic mean radius,  $P$  is the wetted perimeter,  $Q$  is the discharge and  $S$  is the energy gradient. The subscripts used with  $f$  denote the value of silt factor that is used in the appropriate equation. These quantities are conventionally expressed in fps units except  $D_{50}$  which is in mm.

The use of regime equations, (10) to (14) and the significance of regime coefficients  $\alpha_1$ ,  $\alpha_2$ ,  $\alpha_3$  and  $\alpha_4$

have been described elsewhere (2, 4, 5). In brief, if an alluvial channel is to be designed for a specific bed material load, the coefficient  $\alpha_1$ ,  $\alpha_3$  and  $\alpha_4$  can be selected as follows.

i. Coefficient  $\alpha_3$  is basically determined by the erodibility of channel sides. In watercourses,  $2.60 \leq \alpha_3 \leq 2.90$ . The value of  $\alpha_3 = 2.67$  is assumed for illustration.

ii. Coefficient  $\alpha_1$  determines the Froude number,  $F$  of the flow and in general, the bed material transport,  $G$  increases with increasing value of  $F$ . To design the channel for a specific bed material load, a relationship between  $\alpha_1$  and  $G$  is needed. Over a small range of variables involved in sediment transport functions,  $G$  can usually be expressed as a power function of the flow, fluid and sediment properties. This approximation is particularly convenient as compared to the transport computations by more elaborate methods; if (a) the relationships can be either derived or verified from field data, (b) a large number of channel sections is to be designed, (c) the bed form regime in the cases to be considered is entirely lower, or entirely upper, (d) details of bed material load such as the size distribution of the transported material, suspended bed material concentration profiles, etc. are not required. For elliptical watercourse channels, such a relationship based on the detailed computation of equilibrium bed material load by the writer's transport function (1) is:

$$C = 1.05 \times 10^{-4} Q^{0.70} D_{50}^{-4.0} \alpha_1^{6.6} \quad (15)$$

where  $C$  is the bed material concentration in ppm,  $Q$  is the watercourse discharge,  $D_{50}$  is the median bed material size in mm and  $\alpha_1$  is as defined earlier. This equation is based on  $\alpha_2 = 1.15$ ,  $\alpha_3 = 2.67$ ,  $v = 1.1 \times 10^{-5} \text{ ft}^2$  per sec, for lower regime bed forms (ripples and dunes). The range of variables covered by this equation is:  $Q = 1.0$  to  $7.0$  cfs;  $D_{50} = 0.15$  to  $0.20$  mm and  $\alpha_1 = 1.50$  to  $2.00$ . It is entirely possible that the constant and indices in Eq. (15), may differ from region to region due to the omission of variables such as particle shape, specific gravity, temperature, fine material load concentration, etc. Therefore, in a specific design situation, it will be appropriate to determine the numerical constants and indices from local conditions. For illustration, Eq. (15) is used to design the watercourse. For  $C = 186$  ppm,  $Q = 4.0$  cfs and  $D_{50} = 0.16$  mm, Eq. (15) yields  $\alpha_1 = 2.26$ . Thus,

$$\begin{aligned} f_{vr} &= \alpha_1 \sqrt{D_{50}} \\ &= 2.26 \times 0.40 \\ &= 0.91 \end{aligned}$$

For this value of  $f_{vr}$  and for  $\alpha_2 = 1.15$ ,  $\alpha_3 = 2.67$ , the sectional geometry for elliptical channels is derived as follows:

From Eqs. (11) and (12),

$$V = \left\{ \frac{Q f_{vr}^2 \alpha_2^4}{\alpha_3^2} \right\}^{1/6}$$

$$= \left\{ \frac{Q f_{vr}^2}{4.0} \right\}^{1/6}$$

$$= 0.97 \text{ ft per sec.}$$

Also,

$$A = \frac{Q}{V} = \frac{4.0}{0.97} = 4.12 \text{ ft}^2$$

$$P = \alpha_3 \cdot (Q)^{1/2}$$

$$= 2.67 (4)^{1/2}$$

$$= 5.34 \text{ ft}$$

From Eqs. II • 8 and II • 9 (Appendix II), the water surface width,  $W$  and central depth,  $d$  of the elliptical section are obtained as

$$d = \frac{2A}{\sqrt{2P^2 - \pi^2}} = 1.20 \text{ ft}$$

and

$$W = \frac{4A}{\pi d} = 4.37 \text{ ft}$$

#### 7. Resistance Function for the Water Course.

The resistance function used for illustrating the design of water course for turnout no. 3 was earlier developed in reference (1). The hydraulic depth of the channel from the sectional geometry is:

$$d_h = \frac{A}{W} = \frac{4.12}{4.37} = 0.94 \text{ ft}$$

For the assumed bed material size in the watercourse and using the procedure outlined in Chapter 10 of reference 1, the energy gradient for uniform flow is found as:

$$S = 2.60 \times 10^{-4}$$

The corresponding value of Manning's  $n = 0.024$ , average bed shear,  $\tau = 0.015$  psf, stream power,  $\tau v = 0.015$  ft lb per sec per ft<sup>2</sup> and the bed form is ripple.

If the banks of the watercourse channel are well maintained, this value of energy gradient should be adequate. However, if the channel banks are irregular, additional roughness must be provided in the design. Assume that the watercourse banks will deteriorate in time and bank vegetation will be established so that the bank roughness will be given by  $n_b = 0.04$ . The required energy gradient for this case is computed as follows:

$$\text{Wetted perimeter of banks, } P_b = 2 \times d_h = 1.88 \text{ ft}$$

$$\text{Manning's } n \text{ for bank, } n_b = 0.040$$

$$\text{Wetted perimeter of bed, } P_d = P - P_b = 5.34 - 1.88 = 3.46 \text{ ft}$$

$$\text{Manning's } n \text{ for bed, } n_d = 0.024$$

Effective Manning's  $n$  for channel

$$= \frac{n_b P_b^{2/3} + n_d P_d^{2/3}}{(P_b + P_d)^{2/3}}$$

$$= 0.038$$

$$\text{Energy gradient } s = 6.67 \times 10^{-4}$$

8. Summary of Design.

The summary of design for turnout no. 3 and its water course follows:

Turnout setting:

$$Y_t = 0.91$$

$$d_c = 0.36 \text{ ft}$$

Sediment Withdrawal in turnout:

Bed material load concentration = 186 ppm

Median size,  $D_{50} = 0.087 \text{ mm}$

Gradation,  $\sigma = 1.54$

Water Course

Bed material,  $D_{50} = 0.16 \text{ mm}$

$\sigma = 1.31$

Hydraulic Geometry

Channel Section unlined-elliptical

Water surface width,  $W = 4.37 \text{ ft}$

Central depth,  $d = 1.20 \text{ ft}$

Average velocity,  $V = 0.97 \text{ ft per sec}$

Silt factor,  $f_{vr} = 0.91$

Froude number,  $F = 0.176$

Bed form ripple

Energy gradient for  
regular smooth bank  $= 2.60 \times 10^{-4}$   
 $= 1.30 \text{ ft per mile}$

Energy gradient for  
banks with  $n = 0.040$   $= 6.67 \times 10^{-4}$   
 $= 3.34 \text{ ft per mile}$

## V. CONCLUSIONS

Summary

In the irrigation canal networks, supplied by low head diversion structures on sandbed rivers, many sediment exclusion and ejection measures are adopted to reduce the sediment load entering the system. However, all these measures cannot completely eliminate the sediment flow into the system. The disposal of unexcluded sediment entering an irrigation system can be partly made by diverting it with the irrigation supplies. This method is commonly used in the irrigation systems of many developing countries such as India and Pakistan.

The planning of sediment disposal in irrigation systems has been studied on a computer simulated network. The results of this study are:

- (1) A branching network of canals can be designed for disposal of sediment with irrigation supplies. However, such a design needs to consider the sediment discharge limits of the conveyance channels, farm turnouts and watercourse channels.
- (2) The seepage and evaporation losses from a system only remove water and not the sediment load. The average bed material concentration in the irrigation diversions is therefore higher than the incoming concentration of the system.
- (3) The bed material transport capacity of a branching canal network reduces in the direction of flow. If the design of a canal system is to be optimized with respect to the sediment load distribution in the conveyance channels, it is necessary to reduce the concentrations in irrigation diversions from smaller distributary channels.
- (4) For reasons discussed in paragraph 3, the actual bed material concentration in irrigation diversions will vary within the



system. For a system similar to the one simulated in this study, the farm diversions may need to draw 15 to 86 percent greater concentrations than transported by the distributary canals.

(5) The watercourse channels impose the most critical limit on the disposal of sediment through farm diversions. These channels have small discharges, flat slopes, poor maintenance and small bed material transport capacities. If the sediment entry into a water course channel is greater than its transport capacity, the water course loses its water conveyance capacity due to bed aggradation. The net result is frequent interruptions to the on-farm water delivery.

The sediment withdrawal characteristics of the farm turnouts have been studied both analytically and in the laboratory. The results of these studies can be used to design turnouts for specific sediment load withdrawal. The results of laboratory study can be used in smaller distributary channels, transporting most of the sediment as bed load. The analytical study has developed techniques that can be used on larger channels carrying most of the load as suspended load.

The design of watercourse channels for the water and sediment discharge consideration can be based on the laboratory model studies because of the similarity in the scale of phenomena. However, the hydraulic design of watercourse channels should include additional bank roughness for future conditions.

The application of results obtained in this study has been illustrated by designing the farm diversion on a hypothetical channel. The hydraulic resistance and bed material transport functions used in the example were developed earlier from laboratory flumes and field canals data. For field application of the methods presented herein,

it will be necessary to judiciously select the resistance, morphologic and transport relations that are applicable to the region. A field study, to develop simple and gross relationships from existing watercourse channels will be helpful.

Recommendations for Further Research:

A logical corollary to the results presented in this study, is to test them under field conditions. This requires elaborate monitoring studies on existing irrigation systems. The results of the system simulation part of this study provide a guideline for the field study.

The watercourse channels are the smallest conveyance component of an irrigation canal network. For this reason, their study has been largely neglected so far. Yet, it is through the watercourse channels that the final product of an irrigation system is delivered to the consumer. Field studies on: (1) the sediment withdrawal characteristics of the turnouts, (2) the morphologic, resistance and transport characteristics of watercourses are urgently needed. Such studies can be valuable in improving the overall efficiency of the irrigation canal systems.

The present study has been limited to a constant flow and sediment discharge condition. This is a simplifying approximation of the actual conditions in irrigation canal systems, where the discharge and sediment load are continuously varying. The study needs to be extended to time variant flow and sediment hydrographs.

The optimization of sediment disposal in an irrigation canal networks involves multi-disciplinary aspects such as sociological and pedological constraints on the sediment disposal within a system. Also an economic study may elucidate the best economic solution. Such studies are also needed.

## REFERENCES CITED

1. Mahmood, K., Flow in Sand-Bed Channels, CUSUSWASH Water Management Technical Report No. 11, Colorado State University, Fort Collins, Colorado, 1971.
2. Mahmood, K., and H. W. Shen, The Regime Concept of Sediment Transporting Canals and Rivers, Chapter 30, River Mechanics, Vol. II, Ed. H. W. Shen, Fort Collins, Colorado, 1971.
3. Mahmood, K., Sediment Equilibrium Considerations in the Design of Irrigation Canal Networks, Paper No. A-65, International Symposium on River Mechanics, International Association of Hydraulic Research, Bangkok, 1973.
4. Mahmood, K., Sediment Routing in Irrigation Canal Systems, Meeting Preprint No. 1905, ASCE National Water Resources Engineering Meeting, Washington, D. C., 1973,
5. Mahmood, K., Variation of Regime Coefficients in Pakistan Canals, Meeting Preprint No. 2039, ASCE National Transportation Engineering Meeting, Tulsa, Oklahoma, 1973.
6. Nazar, A., A Laboratory Study of Bed Material Withdrawal in Farm Turnouts, M. S. Thesis, Colorado State University, Fort Collins, Colorado, 1973.
7. Rakha, A., Sediment Conduction of Turnouts, M. S. Thesis, Colorado State University, Fort Collins, Colorado, 1971.
8. Rana, S. A., D. B. Simons and K. Mahmood, Analysis of Sediment Sorting in Alluvial Channels, Journal of Hydraulics Division, ASCE vol. 99 No. HY11, Nov. 1973.

APPENDICES

## APPENDIX I

NUMERICAL MODEL FOR DETERMINING SEDIMENT  
WITHDRAWAL IN ORIFICE TYPE TURNOUTS

## Flow Field Due to Distributed Sinks

A uniformly distributed sink of dimensions  $b \times h$  ft and located in X-Y plane is shown in Fig. I.1. The center of this sink is located at  $(x_0, y_0, 0)$  and its discharge is equal to  $mbh$  cfs. At any point  $P(x, y, z)$ , the components of velocity due to this sink,  $u_s$ ,  $v_s$  and  $w_s$  along  $x$ ,  $y$  and  $z$  directions are given by:

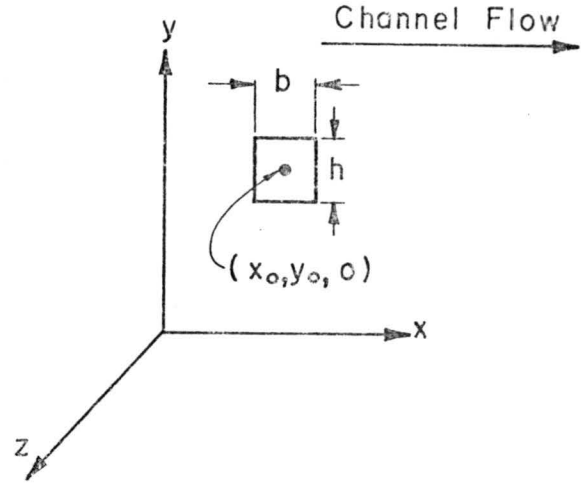
I.1 Uniformly Distributed Sink  
Representing Turnout

$$u_s = \frac{m}{4\pi} \ln \left\{ \frac{y_2 + R_{12}}{y_1 + R_{11}} \cdot \frac{y_1 + R_{21}}{y_2 + R_{22}} \right\} \quad (8)$$

$$v_s = \frac{m}{4\pi} \ln \left\{ \frac{x_2 + R_{21}}{x_2 + R_{22}} \cdot \frac{x_1 + R_{12}}{x_1 + R_{11}} \right\} \quad (9)$$

$$w_s = \frac{m}{4\pi} \left\{ \arctan \frac{y_1 \cdot x_1}{z \cdot R_{11}} - \arctan \frac{y_1 \cdot x_2}{z \cdot R_{21}} \right. \\ \left. + \arctan \frac{y_2 \cdot x_2}{z \cdot R_{22}} - \arctan \frac{y_2 \cdot x_1}{z \cdot R_{12}} \right\} \quad (10)$$

where

$$x_1 = x + \frac{b}{2};$$

$$x_2 = x - \frac{b}{2};$$

$$y_1 = y - y_0 + \frac{h}{2} ;$$

$$y_2 = y - y_0 - \frac{h}{2} ;$$

$$\text{and } R_{ij} = \sqrt{x_i^2 + y_j^2 + z^2} .$$

To represent the velocity field due to an orifice type turnout by a uniformly distributed sink, it is necessary to satisfy the boundary conditions imposed by the channel geometry. These conditions are: at the water surface and the channel bed,  $v_s = 0$ ; at the channel walls except through the turnout,  $w_s = 0$ . The method of images can be used to satisfy these boundary conditions exactly at two surfaces bounding the channel flow and asymptotically at the two remaining surfaces. The arrangement shown in Fig. I.2 exactly satisfies the boundary conditions at the channel wall containing the turnout and the channel bed. The boundary conditions at the water surface can be asymptotically satisfied by increasing the number of images  $j$  in the X-Y plane and the boundary conditions at the farther wall of the channel by increasing the number of images in the Y-Z plane.

#### Superimposition of flow fields:

The flow field due to the sinks is kinematically superimposed on the flow field  $u_c$ ,  $v_c$  and  $w_c$  in the channel. The resulting velocity components at a point  $P(x,y,z)$  in the channel are:

$$u_p = u_s + u_c$$

$$v_p = v_s + v_c$$

$$w_p = w_s + w_c$$

In the undisturbed region of the channel flow  $u_c$  is a function of  $y$  and  $z$  and  $v_c = w_c = 0$ .

It is assumed that at  $x = x_u$ , the flow in the channel is unaffected by the turnout. Starting with different points  $(y_i, z_i)$  in the Y-Z plane at  $x = x_u$ , the path lines are traced up to the Y-Z plane at  $x = x_1$ . The location of the particle at  $x = x_f$  is given by  $x_f, y_f, z_f$  where

$$y_f = y_i + \int_0^{t_f} v_p(x, y, z) \cdot dt \quad (11)$$

$$z_f = z_i + \int_0^{t_f} w_p(x, y, z) \cdot dt \quad (12)$$

$$t_f = \int_0^{x_f} \frac{dx}{u_p(x, y, z)} \quad (13)$$

Equations (11) through (13) are numerically solved. For some of the points  $(x_u, y_i, z_i)$ , the path lines will enter  $S(1,0)$  representing the turnout. The region in Y-Z plane at  $x = x_u$ , from which the path lines enter  $S(1,0)$  is then considered to be feeding water to the turnout. If the curvature of the path lines is negligible, it can be further assumed that the sediment content of this parcel of flow does not alter between the uniform flow in the channel and the entrance to the turnout. For this condition the sediment conduction of the turnout can be determined by the integration of the equilibrium sediment concentration profiles in the channel (1).

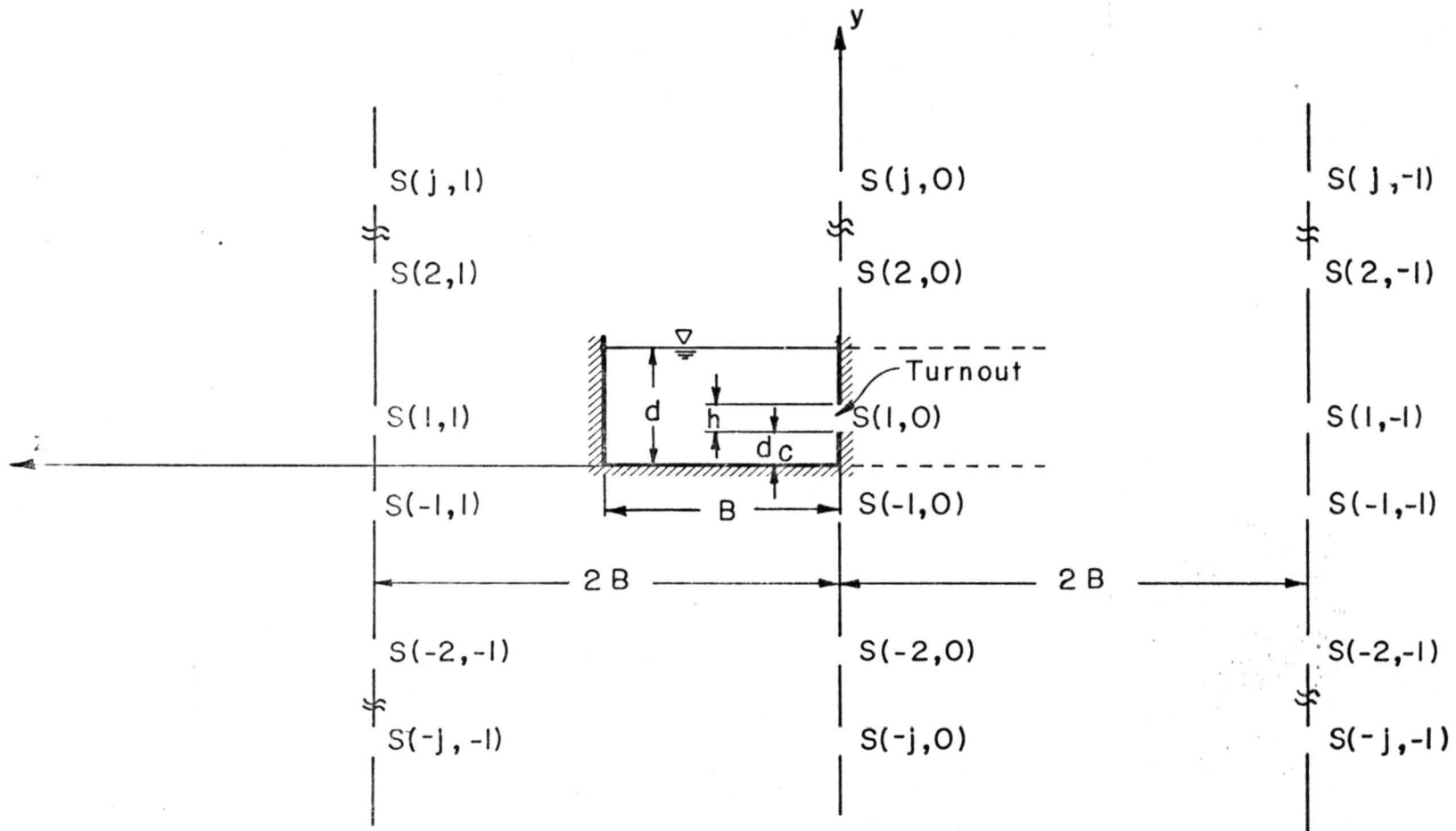

Fig. I.2 Arrangement of Uniformly Distributed Sinks to Satisfy Boundary Conditions for Turnout Flow



## APPENDIX II

SIMILITUDE CRITERIA FOR SEDIMENT  
WITHDRAWAL IN TURNOUTS

Consider a sandbed channel with average suspended bed material concentration,  $\bar{C}$ , flow velocity  $V$ , depth of flow,  $d$ , and suspended bed material load  $g_t$ . Let the dimensionless concentration  $\frac{C}{\bar{C}}$ , velocity  $\frac{u}{V}$  and load,  $\frac{g_t}{\bar{C}Vd}$ , profiles, along the depth, be shown for the channel in Fig. II.1. Now consider two such channels  $m$  and  $p$  with orifice type turnouts set at  $y_t$  so that the ratios between corresponding quantities in these channels are given by:

$$L_r = \frac{L_m}{L_p}; H_r = \frac{H_m}{H_p}; V_r = \frac{V_m}{V_p}; \bar{C}_r = \frac{\bar{C}_m}{\bar{C}_p}; Q_{t_r} = \frac{Q_{t_m}}{Q_{t_p}}$$

$$Q_r = \frac{Q_m}{Q_p}; w_r = \frac{w_m}{w_p}; U_{*r} = \frac{U_{*m}}{U_{*p}},$$

where  $L$  is a horizontal linear dimension,  $H$  is a vertical linear dimension,  $Q_t$  is the discharge in the turnout,  $Q$  is the discharge in the channel,  $w$  is the fall velocity of bed material,  $U_*$  is the shear velocity and other quantities are as defined earlier. Also, the subscripts  $m$  and  $p$  refer to the corresponding quantities in respective channels and subscript  $r$  to their ratio. Assume that the bed material load in both the channels is mainly transported in suspension.

Let channels  $m$  and  $p$  have fully developed rough turbulent flows and also have the following similarities:

- (1) Geometric, so that  $L_r = H_r$
- (2) Froude number, so that  $V_r = H_r^{1/2}$

(3) Rouse number, so that  $w_r = U_{*r}$

(4) Chezy's resistance coefficient, so that  $V_r = U_{*r}$

Then,

$$Q_r = Q_{t_r} = L_r^{5/2}$$

$$q_r = \frac{Q_r}{W_r} = L_r^{3/2},$$

and the dimensionless concentration, velocity and suspended load profile shown in Fig. II.1, are similar for both channels  $m$  and  $p$ . Also, the non-dimensionalized velocity fields due to the distributed sink (representing the turnout)  $\frac{u_s}{V}$ ,  $\frac{v_s}{V}$ , and  $\frac{w_s}{V}$  (refer Appendix I) are similar for the turnouts in channels  $m$  and  $p$ . Thus, the regions of undisturbed flow, feeding the turnouts (Fig. 9), non-dimensionalized over the depth and width of the channel also remain similar between  $m$  and  $p$ . Let  $C_{rat}$  be the ratio of the bed material concentration in the turnout and the channel flow. A straightforward expression for turnouts with a given  $Q_t/Q$  and  $y_t$  in the two channels then shows that  $(C_{rat})_r = 1$ .

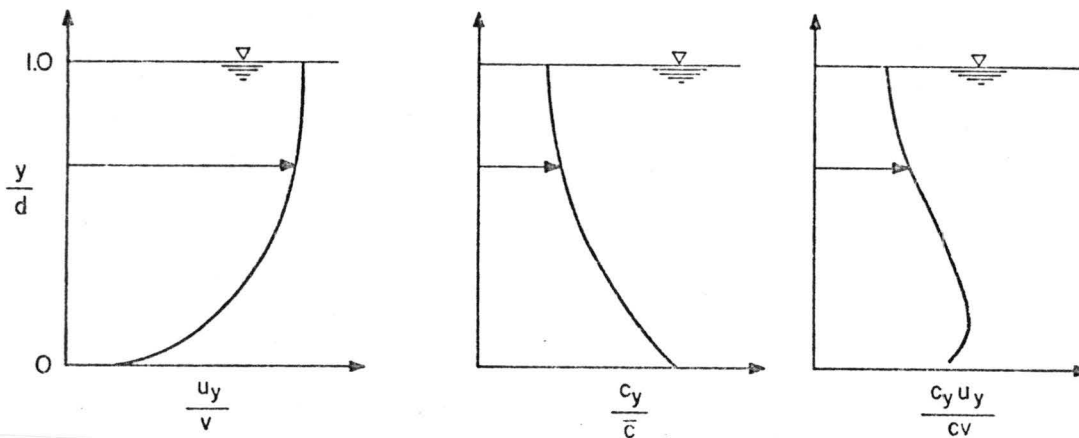

Figure II.1 Non-Dimensional Velocity and Suspended Bed Material Concentration Profiles.

## APPENDIX III

## HYDRAULIC ELEMENTS OF ELLIPTICAL CHANNELS

For elliptical channel sections (Fig. II.1), the hydraulic elements of the section are given

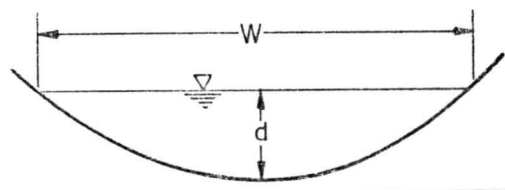

Figure III.1

by:

$$\text{Area of cross-section, } A = \frac{\pi}{4} W \cdot d \quad \text{III.1}$$

$$\text{Wetted Perimeter, } P = WE \quad \text{III.2}$$

$$\text{Elliptical integral, } E = \int_0^{\pi/2} \sqrt{1 - k^2 \sin^2 \theta} \cdot d\theta \quad \text{III.3}$$

$$\text{where, } k^2 = \left(1 - 4 \cdot \frac{d^2}{W^2}\right) \quad \text{III.4}$$

$$\text{Hydraulic Radius, } R = \frac{\pi d}{4E} \cdot \quad \text{III.5}$$

$$\text{Hydraulic depth, } d_h = \frac{A}{W} = 0.785d \quad \text{III.6}$$

As an approximation,  $E$  can be replaced by

$$\hat{E} = \frac{\pi}{2\sqrt{2}} \sqrt{1 + \frac{4d^2}{W^2}} \quad \text{III.7}$$

The error  $\Delta E = E - \hat{E}$  is negative and varies with  $W/D$ . The value of  $\Delta E$  for different  $W/d$  is given below.

| $W/d$ | $\Delta E/E$ |
|-------|--------------|
| 13.3  | -0.090       |
| 4.00  | -0.025       |
| 2.36  | -0.000       |

For a given  $P$ ,  $R$  and  $A$ , the dimensions of an elliptic cross-section, based on  $\hat{E}$  are

$$d = \frac{2A}{\sqrt{2P^2 - \pi^2}} \quad \text{III.8}$$

$$W = \frac{4A}{\pi d} \quad \text{III.9}$$

Eq. III.8 shows that real solutions exist for  $P \geq 2.22$  ft.