

Air Force Institute of Technology

AFIT Scholar

[Theses and Dissertations](#)

[Student Graduate Works](#)

3-2005

A Case Study of the Degree of Collaboration between Various Levels in the Reparable Chain in the United States Air Force

Robert A. Lee

Follow this and additional works at: <https://scholar.afit.edu/etd>



Part of the [Operations and Supply Chain Management Commons](#)

Recommended Citation

Lee, Robert A., "A Case Study of the Degree of Collaboration between Various Levels in the Reparable Chain in the United States Air Force" (2005). *Theses and Dissertations*. 3760.

<https://scholar.afit.edu/etd/3760>

This Thesis is brought to you for free and open access by the Student Graduate Works at AFIT Scholar. It has been accepted for inclusion in Theses and Dissertations by an authorized administrator of AFIT Scholar. For more information, please contact richard.mansfield@afit.edu.



**A CASE STUDY OF THE DEGREE OF COLLABORATION BETWEEN
VARIOUS LEVELS IN THE REPARABLE CHAIN IN THE UNITED STATES
AIR FORCE**

THESIS

Robert A. Lee, Jr., 1 Lt, USAF

AFIT/GLM/ENS/05-13

**DEPARTMENT OF THE AIR FORCE
AIR UNIVERSITY**

AIR FORCE INSTITUTE OF TECHNOLOGY

Wright-Patterson Air Force Base, Ohio

APPROVED FOR PUBLIC RELEASE; DISTRIBUTION UNLIMITED

The views expressed in this thesis are those of the author and do not reflect the official policy or position of the United States Air Force, Department of Defense, or the U.S. Government.

AFIT/GLM/ENS/05-13

**A CASE STUDY OF THE DEGREE OF COLLABORATION BETWEEN
VARIOUS LEVELS IN THE REPARABLE CHAIN IN THE UNITED STATES
AIR FORCE**

THESIS

Presented to the Faculty

Department of Operational Sciences

Graduate School of Engineering and Management

Air Force Institute of Technology

Air University

Air Education and Training Command

In Partial Fulfillment of the Requirements for the
Degree of Master of Science in Logistics Management

Robert A. Lee, Jr., BS

1 Lt, USAF

March 2005

APPROVED FOR PUBLIC RELEASE; DISTRIBUTION UNLIMITED

AFIT/GLM/ENS/05-13

**A CASE STUDY OF THE DEGREE OF COLLABORATION BETWEEN
VARIOUS LEVELS IN THE REPARABLE CHAIN IN THE UNITED STATES
AIR FORCE**

Robert A. Lee, Jr., BS

1 Lt, USAF

Approved:

Stephan P. Brady, Lt Col, USAF (Co-Chairman)

Date

Marvin A. Arostegui, Lt Col, USAF (Co-Chairman)

Date

Abstract

Collaborative Planning, Forecasting, and Replenishment and other logistics processes were developed in the commercial sector to reduce total system costs of production while simultaneously providing reduction in inventory levels, improved customer service levels, greater flexibility in scheduling, greater velocity of inventory through the pipeline, and, as a result, greater profitability (Ploos van Amstel, 1990:1). Many companies including Wal*Mart, Motorola, Target, Johnson & Johnson, and Kellogg's, just to name a few, have seen great achievements since implementing CPFR processes. Can these processes be applied to the Air Force supply chain? This thesis intends to examine the flows and relationships to identify opportunities Air Combat Command Regional Supply Squadron (ACCRSS), Depot Repair Facilities, and Operational Bases.

This research will use a case study approach to address the research and investigative questions. Air Force supply chain management has many responsibilities that must be accomplished. This thesis will seek to look at many of the variables but does not promise to cover all aspects or attempt to provide the ultimate solution. It will merely present the literature reviewed and the data collected and try to draw a conclusion as to whether civilian CPFR techniques can be applied to current Air Force supply chain practices.

Acknowledgments

I would like to express my sincere appreciation to my faculty co-advisors, Lt Cols Stephan Brady and Marvin Arostegui, for their guidance and support throughout the course of this thesis effort. Their insight and experience was certainly appreciated.

Additionally, there were several people involved in the process that I would like to mention. The Item Manager at Warner-Robins Air Logistics Center, Mr. David Hand, the Supply expert at Langley Air Force Base, MSgt Marshaye Cooke, and the resident Intermediate Repair authority at Seymour-Johnson Air Force Base, MSgt Mick Stockwell. Their help, and tolerance of the Lieutenants numerous inane questions, were fundamental to the completion of this work.

Finally, I would like to thank the four most important people in my life, my wife and three children. Without them, I would not have made it through this program or be where I am in my career today.

Robert A. Lee, Jr.

Table of Contents

	Page
Abstract.....	iv
Acknowledgments.....	v
Table of Contents.....	vi
List of Figures.....	x
List of Tables.....	xii
I. Introduction.....	1
Chapter Overview.....	1
Background.....	2
Problem Statement.....	4
Research Question.....	5
Investigative Questions.....	5
Methodology.....	6
Summary and Preview.....	7
II. Literature Review.....	8
Chapter Overview.....	8
Introduction.....	8
History of Process Improvement and Supply Chain Initiatives.....	9
<i>Total Quality Management (TQM)</i>	10
<i>Just in Time (JIT)</i>	13
<i>Material Requirement Planning (MRP)</i>	14
<i>Manufacturing Resource Planning (MRP II)</i>	16
<i>Theory of Constraints (TOC)</i>	18

<i>Distribution Resource Planning (DRP)</i>	20
<i>Enterprise Resource Planning (ERP)</i>	22
<i>Vendor Managed Inventory (VMI)</i>	24
<i>Supply Chain Management (SCM)</i>	26
<i>Collaborative Planning Forecasting and Replenishment (CPFR)</i>	28
<i>Original CPFR Phase I—Planning</i>	30
<i>Original CPFR Phase II—Forecasting</i>	31
<i>Original CPFR Phase III—Replenishment</i>	32
<i>New and Improved CPFR</i>	32
Summary.....	37
III. Methodology	38
Chapter Overview.....	38
Problem Statement.....	38
Research Model.....	39
Case Study.....	42
Data Collection.....	44
Research Design	45
<i>Construct Validity</i>	47
<i>Internal Validity</i>	47
<i>External Validity</i>	47
<i>Reliability</i>	48
Summary.....	48

IV. History and Life of the MPDP	50
Chapter Overview	50
History of the MPDP	50
Life of the MPDP	60
Summary.....	65
V. Tracking the MPDP through the Supply Chain	66
Chapter Overview.....	66
Overall MPDP	66
Seymour-Johnson Air Force Base	74
<i>4th Operations Support Squadron (4 OSS)</i>	74
<i>4th Aircraft Maintenance Squadron (4 AMXS)</i>	76
<i>4th Component Maintenance Squadron (4 CMS)</i>	79
<i>4th Logistics Readiness Squadron</i>	82
Langley Air Force Base.....	86
ACCRSS.....	86
Robins Air Force Base.....	92
<i>Weapons System Supply Chain Manager</i>	92
<i>Integrated Product Team</i>	96
<i>Avionics Repair</i>	100
Summary.....	104
VI. Conclusions and Recommendations	105
Chapter Overview.....	105
Investigative Questions Revisited	106

<i>Investigative Question One</i>	106
<i>Investigative Question Two</i>	108
<i>Investigative Question Three</i>	111
<i>Investigative Question Four</i>	113
Research Question Revisited.....	114
Recommendations for Future Research.....	118
Summary.....	119
Bibliography	120
Vita	128

List of Figures

	Page
Figure 1. Steps in MRP Process.....	15
Figure 2. MRP II Overview	17
Figure 3. CPFR Process Model.....	30
Figure 4. VICS CPFR Top Level Model	33
Figure 5. VICS CPFR Collaboration Tasks Model	34
Figure 6. VICS CPFR Manufacturer and Retailer Tasks Model	36
Figure 7. VICS CPFR n-Tier Collaboration Model.....	37
Figure 8. F-15A Cockpit	53
Figure 9. F-15C Cockpit	54
Figure 10. F-15E Pilot and WSO Cockpits.....	55
Figure 11. F-15E Avionics Architecture.....	57
Figure 12. F-15E Multipurpose Display System Block Diagram.....	58
Figure 13. F-15C Avionics	60
Figure 14. F-15E MPDP Location	61
Figure 15. Typical USAF Logistics Pipeline	63
Figure 16. F-15 Operating Locations.....	67
Figure 17. Historical F-15E Mission Capable Rates	69
Figure 18. Historical F-15E Total Not Mission Capable Supply/Maintenance Rates.....	70
Figure 19. Recent F-15E Top 100 MICAP Drivers by System	72
Figure 20. Recent F-15 Top 10 MICAP Drivers	73

Figure 21. Air Force Single Flying Hour Model	75
Figure 22. Recent 4 CMS MPDP Production	82
Figure 23. LRS Structure	83
Figure 24. LRS Distribution Flight (LGRD) Structure.....	84
Figure 25. RSS Structure	87
Figure 26. WS SCM Scope	95
Figure 27. SMART Example	98
Figure 28. Depot MPDP Production Vs Backorders	103
Figure 29. VICS CPFR Manufacturer and Retailer Tasks Model	115

List of Tables

	Page
Table 1. Principles of TQM	11
Table 2. TOC On-going Process Improvement Steps.....	18
Table 3. DRP Proposals	21
Table 4. ERP Benefits.....	23
Table 5. SCM Key Words.....	27
Table 6. Distinguishing Characteristics of a Qualitative Approach to Research.....	40
Table 7. Distinguishing Characteristics of Different Qualitative Designs	41
Table 8. Components of Case Study Research Design.....	43
Table 9. Case Study Tactics.....	46
Table 10. MPDP Projected Requirements	64

A CASE STUDY OF THE DEGREE OF COLLABORATION BETWEEN VARIOUS LEVELS IN THE REPARABLE CHAIN IN THE UNITED STATES AIR FORCE

I. Introduction

Chapter Overview

This chapter provides a background for the research topic of a case study of the degree of collaboration between various levels in the reparable chain in the United States Air Force. A brief history of recent process improvement and supply chain initiatives will set the stage for future chapters. It then presents the problems and objectives for this research, particularly whether implementation of current Collaborative Planning, Forecasting, and Replenishment (CPFR) techniques being employed in the civilian sector would benefit the processes now being used by the US Air Force. In addition, this chapter will state the overall research question, subsequent investigative questions, and the over arching methodology that will be used during the course of this research. Finally, it will provide a summary and preview the remaining chapters of this thesis.

Background

Logistics and supply management have been around forever and are linked inseparably together. Logistics has, in the past, been primarily concerned with the movement of goods—both incoming goods and the distribution of goods to the next member of the supply chain and frequently to the end customer itself (Burt, et al, 2003:48). Furthermore, Novack, et al state “logistics involves the creation of time, place, quality, form, and possession utilities within and among firms and individuals through strategic management, infrastructure management, and resource management with the goal of creating products/services that satisfy the customer through the attainment of value” (1992, 236). One could easily insert supply management, associated with the procurement, purchasing, and inventory of those goods, into either of the definitions.

Pinkerton states the first broad view of purchasing, in terms of supply management, was the rapid growth of aerospace firms and military logistics during World War II (2000:20). The military needed a way, out of necessity, to manage the immense amount of goods and services provided by all of their contractors; this led to purchasing being grouped with other aspects such as material and distribution management. As early as 1974, traffic and transportation gradually expanded into a definition using the term “logistics” defined as a combination of materials management and physical distribution management (Bowersox, 1974:23). Needless to say, this caused internal disputes because age-old responsibilities were being shifted to new areas. However, it did force all companies to look at the “big picture” for the first time.

Of course, with the advent of new ideas comes the creation of new proposals, and their associated buzzwords. First on the scene were Material Requirement Planning and Manufacturing Resource Planning. These forced the organization to look at the entire flow of both incoming materials and outgoing finished goods as a system (Wight, 1984:221). These were followed by Total Quality Management and Just in Time, made famous by the Toyota Production System (TPS) and well documented in the book by Womack, et al *The Machine That Changed the World* (1991). They clearly affirm the quality-enhancing ideas of W. Edwards Deming that were adopted at about the same time Taichi Ohno was creating his famous TPS (Womack, et al, 1991:277).

The Theory of Constraints was popularized by Eli Goldratt in his 1985 book *The Goal*. It is best viewed as consisting of three legs: logistics concepts, problem solving concepts, and performance measurement concepts (Spencer and Cox, 1995:1495). By identifying bottlenecks (constraints), determining the appropriate batch size, and monitoring the metrics, TOC produces some remarkable results. Distribution Resource Planning talked about total marketing channel integration and how the term logistics was replacing the term distribution (Burt, et al, 2003:35). Harmon suggests the first step is for the company to implement the system in its own distribution and production facilities...then add additional supply network tiers to the already operational system (1993:18); essentially taking MRP and MRP II one step further, and ultimately leading to the computer integration of ERP.

While the previous systems produce good results internal to the firm, Vendor Managed Inventory, Supply Chain Management, and Collaborative Planning,

Forecasting, and Replenishment are capable of great outcomes for all involved. The operative word in all of their definitions is collaboration. While the former arrangements were inward-looking, the latter systems are integrated throughout. So much so that Moore stated part of the genius of Wal*Mart's ecosystem was...its unprecedented involvement and entanglement in the affairs of its suppliers (1996:144). This "involvement and entanglement" requires a totally different mindset, but who can argue with the success of Wal*Mart?

Problem Statement

Collaborative Planning, Forecasting, and Replenishment and other logistics processes were developed in the commercial sector to reduce total system costs while simultaneously providing reduction in inventory levels, improved customer service levels, greater flexibility in scheduling, greater velocity of inventory through the pipeline, and, as a result, greater profitability (Ploos van Amstel, 1990:1). CPFR reduces the amount of capital investment needed throughout the supply chain, provides the right product, at the right price, at the right time, and identifies problems before they occur allowing both parties time to react (Kolacia, et al, 2004).

This thesis intends to examine the material, information, and financial flows of a repairable item in the United States Air Force, and to identify opportunities to improve collaborative relationships for Air Combat Command Regional Supply

Squadron (ACCRSS), Depot Repair Facilities, and Operational Bases. Many companies including Wal*Mart, Motorola, Target, Johnson & Johnson, and Kellogg's, just to name a few, have seen great achievements since implementing CPFR processes. Can these processes be applied to the Air Force supply chain?

Research Question

The focus of this research is to answer the following question: What opportunities exist between Depot Maintenance, Regional Supply Squadron (RSS), and Operational Bases for implementation of the CPFR processes?

Investigative Questions

To answer the research question, this research will address the following investigative questions:

1. What are the material, information, and financial flows of a reparable item in the United States Air Force?
2. What are the partner relationships between Depot Maintenance, RSS, and operational bases?

3. In what areas can Depot Maintenance, RSS, and operational bases realize improvements by adopting CPFR processes?
4. What barriers currently exist to implementing CPFR?

Methodology

This research will use a case study approach to address the research and investigative questions. As will be outlined in the following chapters, Air Force supply chain management has many responsibilities that must be accomplished. This research will seek to look at many of the variables but does not promise to cover all aspects or attempt to provide the ultimate solution. It will merely present the literature reviewed and the data collected and try to draw a conclusion as to whether civilian CPFR techniques can be applied to current Air Force supply chain practices. It essentially asks a “How?” question. “How” questions are more explanatory and likely to lead to the use of case studies. This is because such questions deal with operational links needing to be traced over time, rather than mere frequencies or incidence (Yin, 2003:6).

Summary and Preview

This chapter discussed the background and problem statement, described the research and investigative questions, and provided an overview of the methodology of the research. Chapter II will present an in-depth review of the existing literature pertaining to process improvement and production enhancement, then delve into recent supply chain initiatives. Chapter III will outline the research's methodology of case study and will explain how the data will be collected and analyzed. Chapter IV will provide a case study narrative of a particular National Stock Numbered (NSN) asset and its life cycle from procurement to eventual phase out. Chapter V will track the asset's journey through the Air Force repair pipeline. Finally, Chapter VI will address the findings and answer each of the investigative questions, with the help of the case study and supporting data, and provide conclusions and present areas for future research.

II. Literature Review

Chapter Overview

The purpose of this chapter is to review the terminology and examine current literature concerning Collaborative Planning, Forecasting, and Replenishment (CPFR). This literature review will examine the many Supply Chain initiatives of the recent past, leading us ultimately to the research topic of CPFR.

Introduction

Management of the supply chain deals with the control of material and information flows, the structural and infrastructural processes relating to the transformation of the materials into value added products, and the delivery of the finished product through appropriate channels to customers and markets so as to maximize customer value and satisfaction (Narasimhan and Kim, 2001:52). Over the last quarter of a century, businesses have searched, often in vain, for ways to control their processes and their supply chain. It has almost become a Holy Grail—no doubt due to the barrage of initiatives. As soon as a company decides which one of the latest buzzwords (and its

associated acronym) is best for them and begins implementation, a new and improved initiative hits the market. As these are often total mindset changes, it is not easy or inexpensive for a firm to drop one and begin another. This literature review will examine the many Process Improvement and Supply Chain initiatives of the recent past—to include Total Quality Management, Just in Time, Material Requirement Planning, Manufacturing Resource Planning, Theory of Constraints, Distribution Resource Planning, Enterprise Resource Planning, Vendor Managed Inventory, and Supply Chain Management—leading us ultimately to the research topic of CPFR.

History of Process Improvement and Supply Chain Initiatives

The first topics of Total Quality Management, Just in Time, Material Requirement Planning, Manufacturing Resource Planning, Theory of Constraints, and Distribution Resource Planning are considered by the researcher as Process Improvement Initiatives. While they may occasionally address matters outside of their realm, they deal primarily with the processes and issues within the wall of the factory. Later subjects including Enterprise Resource Planning, Vendor Managed Inventory, Supply Chain Management, and Collaborative Planning, Forecasting, and Replenishment are true Supply Chain Initiatives.

Total Quality Management (TQM)

TQM is based on the teachings of Dr. W. Edwards Deming and Dr. Joseph Juran and their efforts to rebuild the Japanese economy after WWII. It is defined as a cooperative form of doing business that relies on the talents and capabilities of both labor and management to continually improve quality and productivity using teams (Jablonski, 1992:21). There are three key elements in Jablonski's definition—labor and management involvement, continual improvement, and team participation.

Management participation is key but quite often difficult to obtain. It takes a different mindset than what most managers are accustomed to and may well take a lengthy time to develop. The manager must realize that all employees are capable of contributing to the betterment of the company. This alone will begin to knock down those old barriers between management and labor. Continuous Process Improvement means constantly attacking problems as they arise. It recognizes that substantial gains can be achieved by the accumulation of many seemingly minor improvements whose synergies yield tremendous gains over the long run (Jablonski, 1992:22). Finally, TQM involves the creation and cooperation of teams. The teams should be comprised of people who are familiar with the process on all levels—perhaps those who work on the process, those who supply the process, and even customers who benefit from the process. This will ultimately empower the team members to take a look at their routine processes in a different light; to ask, “What can be done to improve our current situation?”

Table 1, Principles of TQM, states Jablonski's six principles of TQM (Jablonski, 1992:24)

Table 1. Principles of TQM

Principles of TQM
1. Customer Focus
2. Focus on Process as Well as the Results
3. Prevention versus Inspection
4. Mobilize Expertise of Workforce
5. Fact-based Decision Making
6. Feedback

(Jablonski, 1992)

These principles are key in the proper implementation of TQM:

1. "Customer focus" not only involves the old-fashioned definition of customer, but it creates a new type of customer. Jablonski defines these customers as "big C" and "little c". "Big C" is the customer we're all familiar with; the one who places an order for a product or service. "Little c" is the person we work with every day within the organization who helps us, or we help them, satisfy "Big C". While we pay constant attention to "Big C", we often overlook and take "little c" for granted. TQM looks to increase awareness of both customers.

2. “Focus on the process as well as the results” gets back to the team aspect. At many points in the process, we are both the customer and provider. If we notice a deficiency in the product, we must strive to improve the process and eliminate that deficiency.
3. “Prevention versus inspection” builds off of Principle #2. In the past, if something was wrong with the process, more inspectors were added to find out exactly what the problem was. Principle #3 allows the individual in the process to recognize the deficiency and offer suggestions to correct it themselves.
4. “Mobilizing expertise of the workforce” squashes the Theory X approach that all workers are mindless robots who must be directed and inherently dislike work. There is an incredible wealth of knowledge in the workforce, and, if empowered by management, that knowledge can be drawn upon for the mutual gain of employee, manager, and ultimately customer.
5. “Fact-based decision making” again relies on the team aspect. If there is a problem with a process, a team can be formed to get to the bottom of it. Experts from all areas will research the issue and provide a fact-based decision rather than randomly assigning blame elsewhere.
6. “Feedback” is the last and possibly the most important principle of TQM—without it, none of the other principles could exist. It involves something as simple as communication, but, in fact, it is often the most difficult to achieve.

Just in Time (JIT)

JIT means producing the right item at the right time in the right quantity (Dennis, 2002:65). JIT is based on the theory of pulling products through a pipeline rather than pushing them. Pull means no one upstream should produce a good or service until a demand has been placed for that good (Womack and Jones, 1996:67). Taichi Ohno, father of the Toyota Production System, introduced JIT in the 1950s to combat the following problems: fragmented markets demanding many products in low volumes, tough competition, fixed or falling prices, rapid changing technology, high cost of capital, and capable workers demanding higher levels of involvement (Dennis, 2002:65) JIT is an ideal state in the flow process, when the parts needed for a process arrive precisely at the time they are needed and only in the amount that is needed (Ohno, 1988:4).

JIT consists of two basic components—Kanban and Heijunka. Kanban is defined as a small sign that contains an instruction to produce or supply something; it is usually a card which includes supplier and customer names, and information on transportation and storage (Dennis, 2002:146). In other words, it is a system of visual tools that provide instructions about a product. Heijunka is simply defined as production leveling (Dennis, 2002:146). The goal is to produce at the same pace every day so as to minimize the peaks and valleys in the workload (Dennis, 2002:70). Essentially, JIT, or Kanban and Heijunka, depends on quick machine changeovers, which allow rapid response to daily customer orders and minimize waiting; capable processes, which mean capable methods, workers, and machines; and visual management through what is known as the 5S system,

which includes steps of sort, set in order, shine, standardize, and sustain (Dennis, 2002:70).

Material Requirement Planning (MRP)

The term MRP implies certain definite system attributes such as time-phased inventory status data, the computation of net requirements, a maximum length of a planning period, a minimum planning horizon span relative to lead time, and the development of so-called planned orders (Orlicky, 1975:44). In other words, MRP takes into account essential data (item, order quantity, date of order, and date of order completion) and determines the requirements needed to order and maintain a correct inventory.

At the heart of MRP is the Master Production Schedule (MPS). It serves as the main input to an MRP system, in the sense that the essential purpose of this system is to translate the schedule into individual component requirements, and other inputs merely supply reference data that are required to achieve this end (Orlicky, 1975:50). The MPS looks at both demand components—forecasts, customer orders, service or spares orders, and safety stocks—and supply components—available inventory, scheduled receipts from production or from suppliers, and planned orders (Scott, 1994:130).

Figure 1, Steps in MRP Process, outlines Scott's basic steps in the MRP processing logic (Scott, 1994:55)

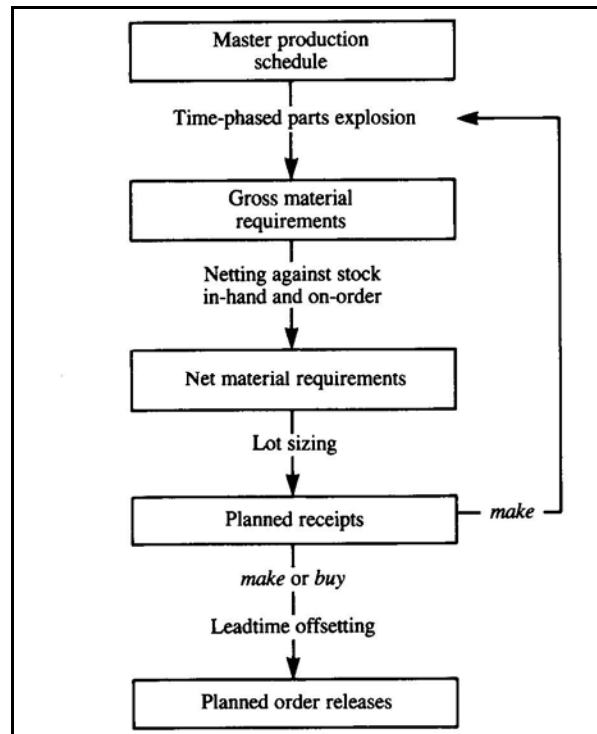

(Scott, 1994)
Figure 1. Steps in MRP Process

The MPS is, as stated previously, what is going to be manufactured/acquired over a period of time. It examines a time-phased parts explosion (what we have against what we need) and determines the gross requirements for the period. That amount is compared to what we have on-hand or on-order to settle on our net material requirements. These net requirements are then grouped into planned order receipts using a lot sizing technique. In the case where some parts are manufactured within the company, that is taken into account and the process returns to the beginning. After all of the above is

settled, the planned order must be approved by the material planner, where the planned order becomes a scheduled receipt (Scott, 1994:55).

One must remember, however, MRP systems in their basic form assume that there are no capacity constraints; that is, they perform infinite loading such that any amount of production is presumed possible (Billington, et al, 1983:17)

Manufacturing Resource Planning (MRP II)

MRP II essentially evolved from MRP. MRP controlled the process through which orders were created but had no resources to identify capacity. There is little point of knowing what work needs to be done to complete an order on time if there is insufficient labor or machine capacity to do it (Luscombe, 1993:11). MRP II uses a Capacity Requirements Planning module to perform this calculation. MRP already had full view of outstanding work, and if the work content of each job is known, it is simple to calculate the overall workload (Luscombe, 1993:12). MRP II is known as a closed loop system. This means that it provides feedback to itself and integrates information from other systems throughout the company.

Figure 2, MRP II Overview, provides a generalized overview of MRP II, its functional levels, and its principal system modules (Scott, 1994:116)

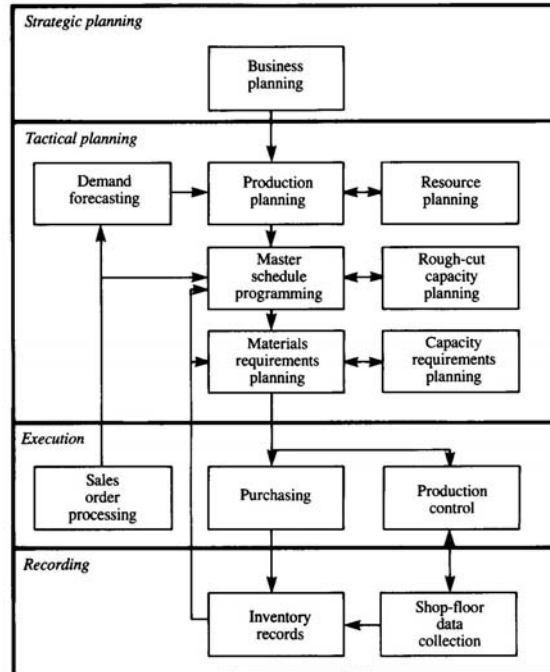

(Scott, 1994)

Figure 2. MRP II Overview

It is important to note that not all MRP II systems are identical to the overview above, but it is a viable template. Some have more modules and some have less; but as long as they are a closed-loop MRP system with feedback and integration, they are considered MRP II. Of course, the model begins with the Strategic level. This is the vision of the Board of Directors and Chief Executives. Next is the Tactical level where effectively MRP is taking place, with, of course, a Capacity Requirements Planning

module. The Execution and Recording levels are operational stages that order/purchase and provide feedback to the system, respectively.

Theory of Constraints (TOC)

TOC is an overall, no nonsense management philosophy developed by Dr. Eliyahu M. Goldratt. It acknowledges that every company has a general purpose or goal. Equally, every organization has obstacles preventing it from achieving their goal called constraints. Dr. Goldratt states that a system's constraint is anything that limits a system from achieving higher performance versus its goal (Goldratt, 1990:4). Table 2, TOC On-going Process Improvement Steps, outlines his five step process of on-going improvement (Goldratt, 1990).

Table 2. TOC On-going Process Improvement Steps

TOC On-going Process Improvement Steps
1. Identify the System's Constraints
2. Decide How to Exploit the System's Constraints
3. Subordinate Everything Else to the Above Decision
4. Elevate the System's Constraints
5. If in the Previous Steps a Constraint has been Broken, go back to Step 1

(Goldratt, 1990)

These improvement steps are vital in applying the tenets of TOC:

1. Identify the system's constraints. Sometimes there may be more than one constraint. In this case, the constraints must be prioritized according to their impact on the goal and worked in order.
2. Decide how to exploit the system's constraints. After we decide which processes, steps, machines, etc. are constraints, obviously the processes, steps, machines, etc. left are not constraints. Since the overall performance of the system is controlled by the constraints, there is no reason to provide the constraints any more than they can handle. This is accomplished by pushing the non-constraints only as hard as needed to supply the constraints.
3. Subordinate everything else to the above decision. Concentrate entirely on the decision made in step 2. If there is no way to reduce the effect of the constraint, move on to the next constraint.
4. Elevate the system's constraints. It stands to reason that when all constraints are resolved, then pushed farther, there will be new constraints. When this happens, we go to step 5.
5. If in the previous steps a constraint has been broken, go back to step 1. Goldratt states that you will very rarely find a real constraint, but rather policy constraints (Goldratt, 6). These policies, when instituted, were probably logical. However, the original reason for the policy has probably disappeared and needs to be looked at again.

Distribution Resource Planning (DRP)

DRP promises to do what many of the previous initiatives offer—improve customer service, improve inventory turnover, increase profits, reduce costs of operations, and improve quality of business life. The most notable change from other ideas is DRP concerns itself primarily in managing inventory in multiple stocking locations or sourcing from multiple suppliers and/or plants (Smith, 1991:149). It allows scheduling groups of products from multiple locales from multiple sources. DRP is modeled to determine the appropriate routes and inventory policies for a set of warehouses and retailers. Given warehouse and retailer locations, inventory and transportation costs, and demand forecasts for each retail outlet, these Decision-Support Systems utilize analytical techniques to determine policies that will achieve high levels of customer service at minimal cost (Simchi-Levi, et al, 2000:267).

Table 3, DRP Proposals, lists proposals of what exactly DRP can offer a company (Smith, 1991:112).

Table 3. DRP Proposals

1. Orders Inventory	10. Does Break Bulk Allocations
2. Cancels/Reduces Excess Inventory	11. Gets Steady Input from Major Customers
3. Informs Suppliers about Future Orders	12. Creates Action Messages
4. Allocates Scarce Inventory	13. Matches Service-Turnover Needs to Capacity
5. Identifies Excess Inventory	14. Converts Customer Item Numbers to Ours
6. Redistributes Excess Inventory	15. Does Joint Replenishment for Transportation
7. Summarizes Measures of Performance	16. Handles Multiplant/Multiwarehouse Inventories
8. Projects Resource Needs	17. Provides input for Electronic Data Interchange
9. Uses Exception Reporting	18. Allows using JIT logic Efficiently

(Smith, 1991)

Smith offers that these proposals will solve a multitude of problems. He lists bad records, lead time inconsistencies, quality problems, excess inventory issues, order-filling errors, unrealistic goals, and a multitude of others (Smith, 1991:114). Again, the key word is “multiple.” It helps the manufacturing company correctly plan production against a forecast of total demand. Wholesalers can stop treating their suppliers poorly by providing them a good forecast. And finally, retailers can reap the DRP advantages above and pass on those benefits to the customer.

As stated previously, the first topics of TQM, JIT, MRP, MRP II, TOC, and DRP are considered as Process Improvement Initiatives dealing primarily with the processes and issues within the wall of the factory. We now move to the true Supply Chain Initiatives Later of Enterprise Resource Planning, Vendor Managed Inventory, Supply Chain Management, and Collaborative Planning, Forecasting, and Replenishment.

Enterprise Resource Planning (ERP)

ERP looks at exactly what its name implies—the entire enterprise. The previous initiatives looked for the most part inwardly, but ERP looks at the complete process and goes one step further; the core idea of ERP is complete integration of an organization's computing system (Olson, 2004:20). It is the next logical step in an evolutionary series of computer tools that began in the 1950s (Ptak, 2004:11). By doing so, it has also been credited with creating value through integrating activities across a firm, implementing best practices for each business process, standardizing processes within organizations, creating one-source data that results in less confusion and error, and providing on-line access to information (O'Leary, 1999:108).

Ptak states that ERP is far more than just MRP II running on client-server architecture; it includes all the resource planning for an entire enterprise to include product design, information warehousing, material planning, capacity planning, and communication systems to just name a few (2004:11). Langenwalter views ERP (or

Total Enterprise Integration) as a way to integrate the entire organization (2000:19).

Table 4, ERP Benefits, lists the expected areas of improvement; these areas will be expounded upon following the table (Langenwalter, 2000).

Table 4. ERP Benefits

1. Executive Direction and Support
2. Customer Integration
3. Engineering Integration
4. Manufacturing Integration
5. Support Services Integration

(Langenwalter, 2000)

The benefits are further defined in the statements to follow:

1. If executives “buy-in”, ERP systems may be used for strategic (long-term) planning, marketing (what does the customer want?) planning, sales and operations (short-term) planning, financial (monetary impact of each function) planning, measurement systems (metrics), and SCM integration (Langenwalter, 2004:19-59).

2. If the customers are fully integrated, ERP systems may be used for full sales support, sales forecasting, order entry and generation, quoting and promising deliveries, demand management, overall logistics to include distribution, and even field service (Langenwalter, 2004:59-111).

3. When the engineering aspect is fully integrated, ERP systems may be used for the design process, product phase-out, product data management, project management, and integrating the suppliers and customers with the rest of the company (Langenwalter, 2004:113-151).

4. When the manufacturing aspect is fully integrated, ERP systems may be used for material and capacity planning, Manufacturing Execution Systems, Just in Time, Advanced Planning and Scheduling, supplier integration, quality management systems, and maintenance (Langenwalter, 2004:153-208).

5. When support services aspect is fully integrated, ERP systems may be used for accounting, costing, human resources, and environmental management (Langenwalter, 2004:209-238).

Vendor Managed Inventory (VMI)

VMI can be generically characterized as a collaborative strategy between a customer and supplier to optimize the availability of products through a continuous replenishment approach to the management of inventory in the supply chain (Hines, et al, 2000:339). It fundamentally allows the supplier to manage inventories previously managed by the customer, thereby creating one less link in the supply chain. It does not absolve the customer from his responsibility, as it is he who is responsible for setting the framework within which the system operates and for continually monitoring and

adjusting the characteristics of this framework (Hines, et al, 2000:339). In an ideal world, the two partners should be involved in an ongoing process of continuing improvement, searching for ways to improve either or both of their processes.

Both suppliers and customers benefit from a well engineered VMI system. The supplier can be more flexible through greater demand accuracy and operational flexibility. This is accomplished by creating shorter lead times, due to the elimination of the additional link, and better use of working capital. He can also save money from “Customer Switching Costs,” the costs associated with a customer moving to an alternate supplier (Hines, et al, 2000:350). The customer, of course, may benefit, as well. Reduced administrative costs will result in enhanced cash flow. There is less risk involved because your inventory is being handled by a specialist and chances are great that your inventory will be reduced. With improved inventory, there is an opportunity to improve service levels.

Alternatively, there are potential disadvantages of a badly engineered VMI system. In a relationship conceived from a customer power position where the inventory management burden is intentionally off-loaded to the supplier, the supplier is likely to incur both increased administration and inventory costs with a negative impact on liquidity and cash flow (Hines, et al, 2000:351). This may help the customer in the short run, but the relationship is doomed. Perhaps one of the greatest disadvantages is risk. If the system is not properly engineered and the supplier is sole sourced, the entire operation may come to a complete stop if something happens to the supplier. Also, the

supplier may handle one of the customer's key competitors. As they are handling some of their potentially sensitive data, the customer must satisfy themselves that all is well.

Supply Chain Management (SCM)

SCM started in the late 1980s and became popular in the 1990s. Perhaps it has always been around only called different names such as logistics and operations. SCM is the coordination of production, inventory, location, and transportation among the participants in a supply chain to achieve the best mix of responsiveness and efficiency for the market being served (Hugos, 2003:4). Many of these terms are associated with the term logistics, but SCM also includes activities such as marketing, new product development, finance, and customer service (Hugos, 2003:5). Furthermore, the Council of Supply Chain Management Professionals states the following:

“Supply Chain Management encompasses the planning and management of all activities involved in sourcing and procurement, conversion, and all Logistics Management activities. Importantly, it also includes coordination and collaboration with channel partners, which can be suppliers, intermediaries, third-party service providers, and customers. In essence, Supply Chain Management integrates supply and demand management within and across companies.”
(CSCMP Website, 2004)

Table 5, SCM Key Words, focuses on the key words in Hugos' definition of SCM.

Table 5. SCM Key Words

SCM Key Words
1. Production
2. Inventory
3. Location
4. Transportation
5. Information

(Hugo, 2003)

These key words lead the Supply Chain Manager to ask certain questions that are critical in the development and management of a supply chain:

1. What product does the market want, and how much of which products should be produced and by when (Hugos, 2003:5)? Production refers to the capacity of a supply chain to make and store products. The facilities of production are factories and warehouses (Hugos, 2003:10)
2. What inventory should be stocked at each stage in a supply chain, and how much inventory should be held as raw materials, semi finished, or finished goods (Hugos, 2003:5)? Inventory is spread throughout the supply chain and includes everything from raw materials to work in process to finished goods that are held by the manufacturers, distributors, and retailers in a supply chain (Hugos, 2003:12).

3. Where should facilities for production and inventory storage be located; where are the most cost efficient locations for production and for storage of inventory (Hugos, 2003:5)?

Location refers not only to the geographical siting of the supply chain facilities, but it also includes the decisions related to which activities should be performed in each facility (Hugos, 2003:13).

4. How should inventory be moved from one supply chain location to another (Hugos, 2003:6)? This refers to the movement of everything from raw materials to finished goods between different facilities in a supply chain (Hugos, 2003:14).

5. How much data should be collected and how much information should be shared (Hugos, 2003:6)? This is the keystone of SCM. Information is used for two key purposes in SCM—coordinating daily activities and forecasting and planning (Hugos, 2003:16).

These questions cover the What, Where, and How questions, but it is essential to remember, none of these questions can be answered until the Who question is posited and satisfied. The firm needs to ensure they acquire the proper Supply Chain Manager who can see to all of these questions.

Collaborative Planning Forecasting and Replenishment (CPFR)

CPFR is a business practice that combines the intelligence of multiple trading partners in the planning and fulfillment of customer demand; it links sales and marketing

best practices, such as category management, to supply chain planning and execution processes to increase availability while reducing inventory, transportation and logistics costs (VICS, 2004). The Voluntary Interindustry Commerce Standards (VICS) Association is the owner of the CPFR trademark and steward of the CPFR committee. VICS has been in existence since 1986 and has worked to improve the efficiency of the entire supply chain by establishing cross-industry standards that simplify the flow of product and information in the general merchandise retail industry for retailers and suppliers alike.

Crum and Palmatier state it takes a minimum of ten years for fundamental changes in business practices to become widely adopted; it takes another five to ten years for these changes to become a routine way of doing business for the majority of companies (2003:198). CPFR is in the early stages of adoption. Innovators, like Proctor & Gamble, Wal-Mart, Warner-Lambert, Kimberly Clark, Nabisco, Wegmans, and Sara Lee, are proving that collaboration to plan demand and replenishment strips costs from the supply chain—to the financial benefit of all trading partners; now early adopters are following the leadership of these pioneers (Crum and Palmatier, 2003:198).

The CPFR (nine steps) planning process structures the relevant steps of the implementation process of CPFR (Seifert, 2003:34). Initially, CPFR was divided into three phases. Figure 3, CPFR Process Model, displays the three phases of the original process—planning, forecasting, and replenishment (VICS, 2002)

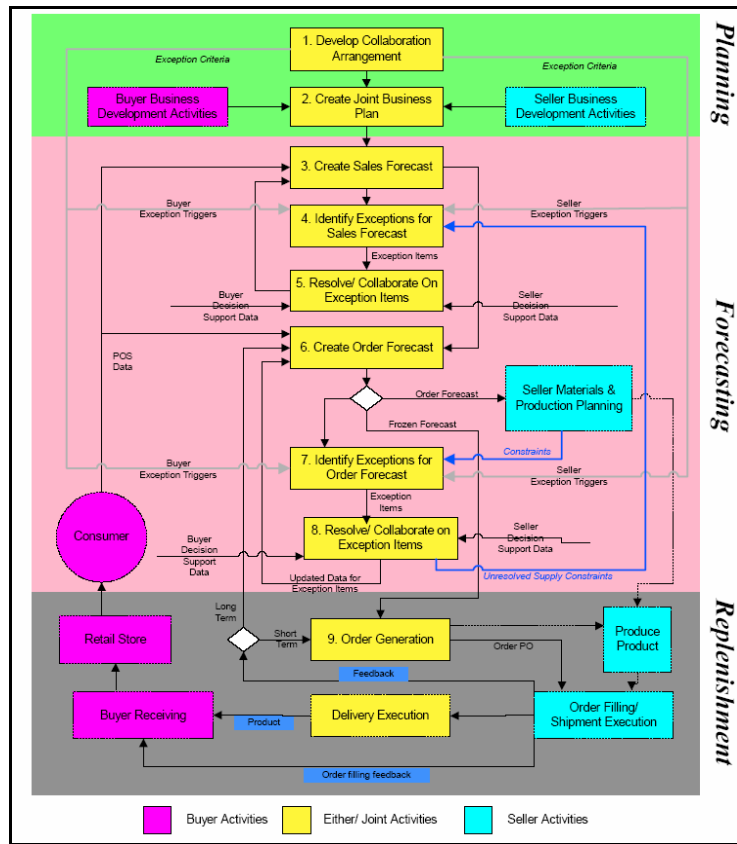

Figure 3. CPFR Process Model (VICS, 2002)

Original CPFR Phase I—Planning

Step 1 in the process fundamentally establishes rules of engagement, as far as collaboration is concerned, between the two parties involved. It is the most involved step because the two parties are defining the relationship for the first time. It includes developing and refining the following: CPFR mission statement, CPFR goals and objectives, individual competencies and resources, collaboration points and responsible

business functions, information-sharing needs, service and ordering commitments, resource involvement and commitments, differences between partners, review cycle information, and publishing the front-end agreement (Seifert, 2003:36). Step 2 allows both partners to take all of the information in Step 1 and create a contract between the two. The development of a joint business plan improves the overall quality of forecasting by including data from both parties (VICS, 2002). The plan offers a platform for communication and coordination along the supply chain (Seifert, 2003:37).

Original CPFR Phase II—Forecasting

Steps 3 through 8 were situated in the forecasting phase. All upcoming sales data—point of sale, promotions, seasonal products, etc.—help determine the sales forecast in Steps 3 and 4. In Step 5, the partners jointly identified any exceptions brought up in the prior steps. Bare in mind, all of these steps are real-time so communication is a must! Each change flows immediately in to the new forecast; the accelerated communication and decision making by producers and retailers increases the reliability of the order that is generated (Seifert, 2003:38). Steps 6 through 8 are similar; however these steps deal with the order forecast instead of the sales forecast. Again, through constant communication, changes caused by exception are updated immediately.

Original CPFR Phase III—Replenishment

In Step 9, the order forecast becomes an actual order. Order generation can be handled by either the manufacturer or retailer depending on competence in the process, access to appropriate technology, and the availability of free resources (Seifert, 2003:38). Regardless of who completes this task, the created order is expected to consume the forecast (VICS, 2002).

New and Improved CPFR

In the recent past, the experience gained from implementations of CPFR in companies around the globe has generated many new ideas. A joint committee of VICS and the Efficient Consumer Response (ECR) organization revised the guidelines slightly in 2001 to incorporate global requirements, sanctioned by the Global Commerce Initiative (GCI); in 2004, the VICS CPFR committee developed a major revision of the CPFR model to integrate innovations and overcome shortcomings identified in the original process (VICS, 2004).

Figure 4, VICS CPFR Top Level Model, displays the overview of CPFR (VICS, 2004).

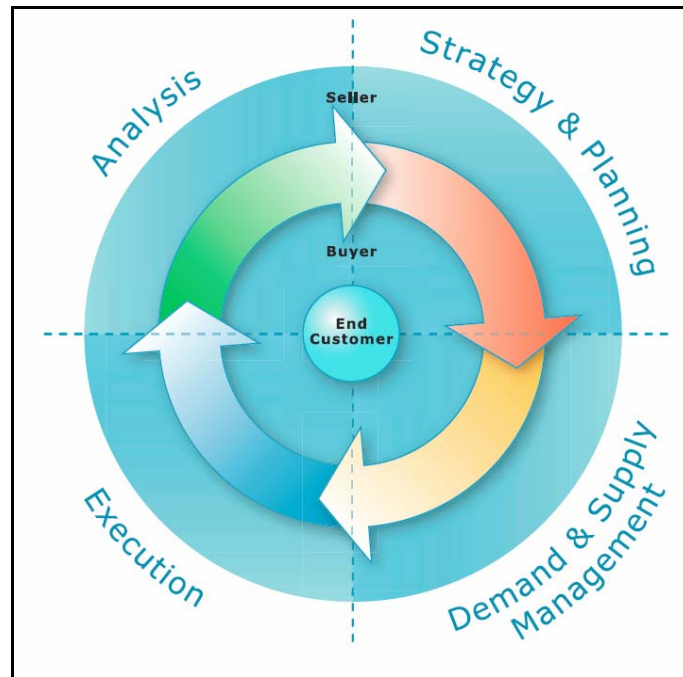

Figure 4. VICS CPFR Top Level Model (VICS, 2002)

In the Top-level model, the terms buyer and seller are generalized; different business situations determine who plays which role. As defined in Figure 4, there are four stages of the CPFR Top-level model. In the Strategy and Planning stage, the ground rules for the collaborative relationship are established, product mix and placement are determined, and event plans for the period are developed (VICS, 2004). The Demand & Supply Management stage projects consumer (point-of-sale) demand, as well as order and shipment requirements over the planning horizon (VICS, 2004). Next is the Execution stage where orders are placed, shipments are prepared and delivered, products

on retail shelves are received and stocked, sales transactions are record and payments made (VICS, 2004). Finally, the Analysis stage monitors planning and execution activities for exception conditions, aggregates results, calculates key performance metrics, and shares insights and adjust plans for continuously improved results (VICS, 2004).

It is important to note that, although these stages are represented in a commonsensical order, most businesses are involved in any or all of the steps at the same time. For instance, the Analysis stage may show metrics which lead us to investigate steps in the Demand and Supply Management stage.

Figure 5, VICS CPFR Collaboration Tasks Model, begins to delineate the steps in true collaboration. These steps are similar to the nine original steps, just refined over the years (VICS, 2004).

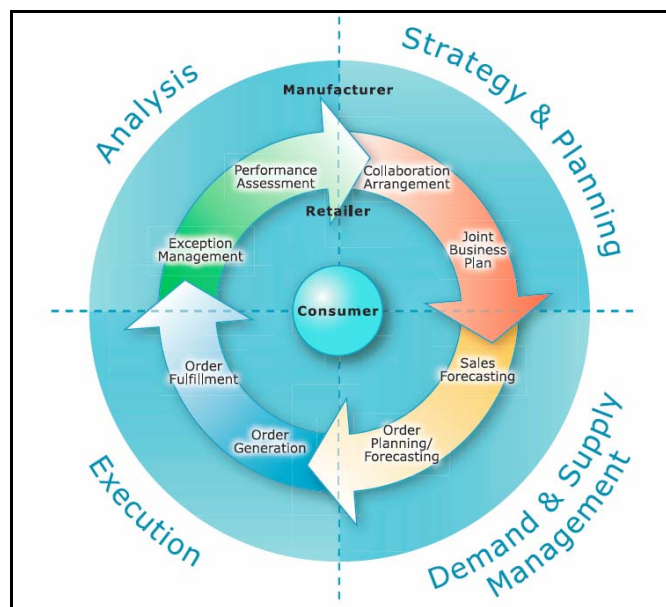

Figure 5. VICS CPFR Collaboration Tasks Model
(VICS, 2002)

Within Strategy & Planning are the processes of Collaboration Arrangement and Joint Business Plan. Representatives from each firm set goals, the scope of the collaboration is stated, and roles and responsibilities of each partner are detailed. Demand and Supply Management is broken into Sales Forecasting and Order Planning/Forecasting. Again, representatives responsible in these areas determine consumer demand at the point of sale and forecasted requirements. Next is the Execution process consisting of Order Generation and Order Fulfillment where forecasts are converted to actual demand and products are produced and delivered. Lastly, the Analysis process includes Exception Management and Performance Assessment. Here, delegates look at the entire collaboration effort and provides key metrics to highlight both negatives and positives.

Figure 6, VICS CPFR Manufacturer and Retailer Tasks Model, delegates essential responsibilities to the manufacturer and retailer (VICS, 2004). For each action in the process for the retailer, there is an opposing, or in this case, a collaborative step in the process for the manufacturer. Manufacturers and retailers are encouraged to get acquainted with each others processes for the ultimate betterment of the two. Again, this is a CPFR model—not all of these steps will occur in every situation. These are just culled from past case studies.

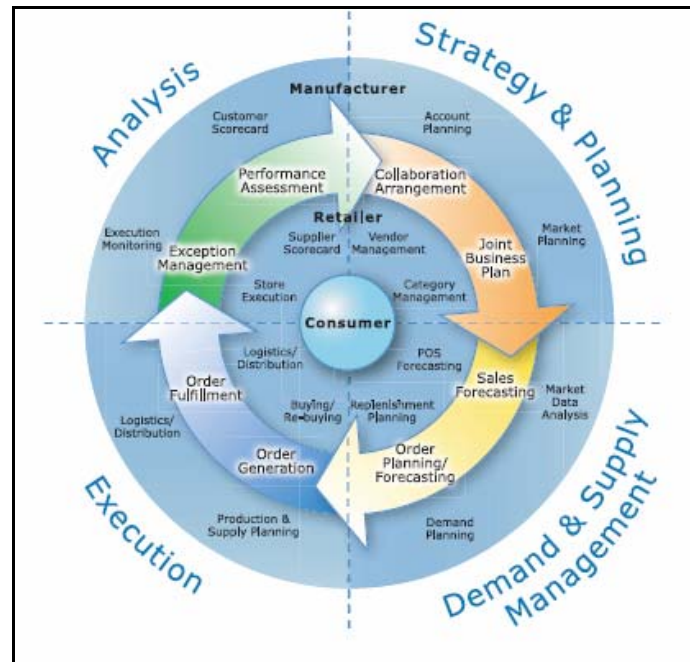

Figure 6. VICS CPFR Manufacturer and Retailer Tasks Model
(VICS, 2002)

Lastly, to get a true “big picture” of collaboration, VICS offers the n-Tier Collaboration Model shown in Figure 7, VICS CPFR n-Tier Collaboration Model (VICS, 2004). The original model pertained to two partners, or two-tier. N-tier collaboration is the term VICS uses to describe relationships that progress from retailers through manufacturers or distributors to suppliers (2004). They further state the multiple partners should share certain information as close to real-time as possible or needed between multiple tiers of a value chain (and that) will minimize the impact of change and thus improve the performance of that chain; the idea of “end-to-end collaboration” is greater than CPFR, and greater than the sum of multiple CPFR parts (VICS, 2004).

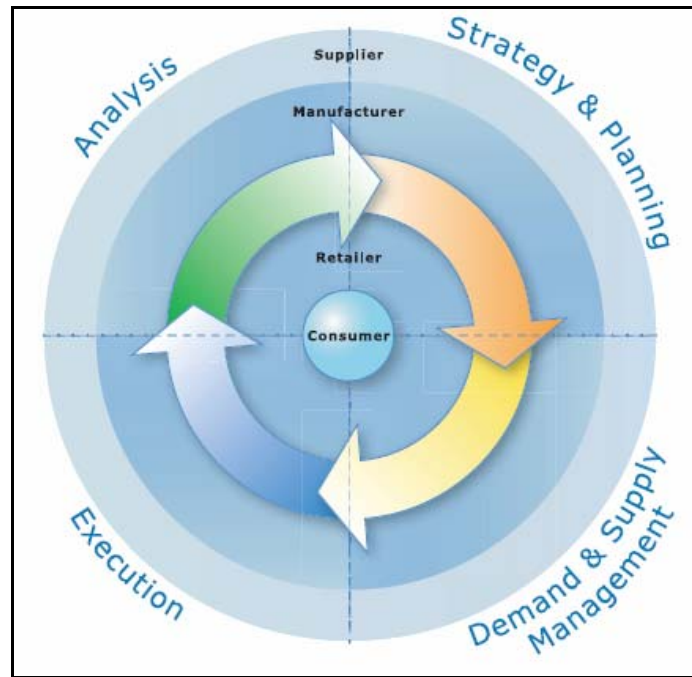

Figure 7. VICS CPFR n-Tier Collaboration Model
(VICS, 2002)

Summary

This literature review detailed the many initiatives of the recent past—including Total Quality Management, Just in Time, Material Requirement Planning, Manufacturing Resource Planning, Theory of Constraints, Distribution Resource Planning, Enterprise Resource Planning, Vendor Managed Inventory, and Supply Chain Management—and lead ultimately to the research topic of CPFR. It reviewed the original nine-step CPFR guidelines and also the new four stage model. Chapter 3 will contain the methodology of the thesis.

III. Methodology

Chapter Overview

The purpose of this chapter is to describe the methodology used to conduct the research. It will review the research problem and its associated investigative questions and describe the research model selected to carry out this study.

Problem Statement

The purpose of this research is to discover if opportunities exist between Depot Maintenance, Regional Supply Squadron (RSS), and Operational Bases for implementation of the CPFR processes and can those processes be effectively applied to the existing supply chain techniques currently used in the Air Force. In the Literature Review, previous initiatives were discussed to understand their history leading us ultimately to our research topic of CPFR. The thesis seeks to apply CPFR practices to the Air Force logistics chain.

To address this research problem, the investigative questions, initially outlined in Chapter One will be addressed:

1. What are the material, information, and financial flows of a reparable item in the United States Air Force?
2. What are the partner relationships between Depot Maintenance, RSS, and operational bases?
3. In what areas can Depot Maintenance, RSS, and operational bases realize improvements by adopting CPFR processes?
4. What barriers currently exist to implementing CPFR?

Research Model

This research is entirely qualitative. “A qualitative study is one designed to process an understanding of a problem, based on building a complex picture, formed with words, and reporting detailed views of informants” (Creswell, 2003). It is typically used to answer questions about the complex nature of phenomena, often with the purpose of describing and understanding the phenomena from the participants’ point of view (Leedy and Ormrod, 2001:101). Leedy and Ormrod also state, as opposed to quantitative researchers, qualitative researchers often start with general research questions rather than specific hypotheses, collect an extensive amount of verbal data from a small number of participants, organize those data into some form that gives them coherence, and use verbal descriptions to portray the situation they have studied (Leedy and Ormrod, 2001:101). Frankfort-Nachmias and Nachmias also add the research should attempt to

understand behavior and institutions by getting to know the persons involved and their values, symbols, beliefs, and emotions (1996:281)

Based on the qualitative nature of the research, a qualitative design was used to conduct the study, analyze the data, and derive theory. Table 6, Distinguishing Characteristics of a Qualitative Approach to Research, outlines how this research fits a qualitative approach and compares the research to characteristics defined by Leedy and Ormrod (Leedy and Ormrod, 2001:102).

Table 6. Distinguishing Characteristics of a Qualitative Approach to Research

Question	Qualitative	Research Characteristic that Conforms to Approach
What is the purpose of the research?	<ul style="list-style-type: none"> - Describe and explain - Explore and interpret - Build Theory 	<ul style="list-style-type: none"> - To study if CPFR processes can be applied to the AF repairable supply chain
What is the nature of the research project?	<ul style="list-style-type: none"> - Holistic - Unknown Variables - Flexible guidelines - Emergent design - Context-bound - Personal view 	<ul style="list-style-type: none"> - Literature review - Data Collection - Interviews - Case Study selected - Theory will emerge
What are the methods of data collection?	<ul style="list-style-type: none"> - Informative, small sample - Observations, interviews 	<ul style="list-style-type: none"> - Literature review - Data collected from interviews, observations
What is the form of reasoning used in the analysis?	<ul style="list-style-type: none"> - Inductive analysis 	<ul style="list-style-type: none"> - No current research exists on this subject - Goal is to generate theory
How are the findings communicated?	<ul style="list-style-type: none"> - Words - Narratives, individual quotes - Personal voice, literary style 	<ul style="list-style-type: none"> - Data displayed in tables, text - Theory communicated in thesis

(Leedy and Ormrod, 2001)

Furthermore, after analyzing various qualitative research methods, a case study approach was selected to conduct this research. “A case study can be defined as an empirical study that investigates a contemporary phenomenon within its real-life context,

when the boundaries may not be clearly evident” (Yin, 2003:13). Table 7, Distinguishing Characteristics of Different Qualitative Designs, outlines five qualitative methods. Of the five methods listed, due to the best fit of the purpose, focus, and fit categories below, the case study method fits this research the best and is used to conduct the research (Leedy and Ormrod, 2001:157).

Table 7. Distinguishing Characteristics of Different Qualitative Designs

Design	Purpose	Focus	Methods of Data Collection
Case Study	To understand one person or event in depth	One case or a few cases within its natural setting	- Observations - Interviews - Appropriate written documents
Ethnography	To understand how behaviors reflect the culture of a group	A specific field site in which a group of people share a common culture	- Participant observation - Interviews with informants - Artifact/document collection
Phenomenological Study	To understand an experience from the participants’ point of view	A particular phenomenon as it is typically lived and perceived by humans	- In-depth, unstructured interviews - Purposeful sampling of 5-25 individuals
Grounded Theory Study	To derive a theory from data collected in a natural setting	Human actions and interactions, and how they result from and influence one another	- Interviews - Any other relevant data sources
Content Analysis	To identify the specific characteristics of a body of material	Any verbal, visual, or behavioral form of communication	- Identification and possible sampling of the specific material to be analyzed - Coding of the material in terms of predetermined and precisely defined characteristics

(Leedy and Ormrod, 2001)

Case Study

The case study involves observations of a single group or event at a single point in time (Frankfort-Nachmias and Nachmias, 1996:146). More specifically, it is a research strategy which focuses on understanding the dynamics present within the single setting (Eisenhardt, 1989:534). As stated previously, Yin defined the case study as an empirical study. He further states the case study accomplishes the following: copes with the technically distinctive situation in which there will be many more variables of interest than data points; relies on multiple sources of evidence, with data needing to converge in a triangulating fashion; and benefits from the prior development of theoretical propositions to guide data collection and analysis (Yin, 2003:14).

The phenomenon of Air Force supply chain management has many moving parts and multiple roles and responsibilities that must be accomplished, often by separate individuals and in isolation. This research will endeavor to look at many of the variables but does not promise to cover all aspects or attempt to provide the ultimate solution. It will merely present the literature reviewed and the data collected and try to draw a conclusion as to whether CPFR techniques can be applied to current Air Force supply chain practices.

It essentially asks a “How?” question. “How” questions are more explanatory and likely to lead to the use of case studies. This is because such questions deal with operational links needing to be traced over time, rather than mere frequencies or

incidence (Yin, 2003:6). Of course, when we ultimately answer the “How” questions, we can then answer the “Who,” “What,” “When,” and “Where” questions.

For case studies, Yin suggests five components of research design which are especially important; (Yin, 2003:21) these appear in Table 8, Components of Case Study Research Design.

Table 8. Components of Case Study Research Design

Components of Case Study Research Design
1. A study’s questions.
2. Its propositions, if any.
3. Its unit(s) of analysis.
4. The logic linking the data to the propositions.
5. The criteria for interpreting the findings.

(Leedy and Ormrod, 2001)

These components lead the researcher to determine if the body of work qualifies for the qualitative case study:

1. These questions were outlined in Chapter One. As previously mentioned, these questions lead us to a “How?” question.
2. This research has an underlying proposition. We know that collaborative relationships have shown to be successful in the civilian sector. Our underlying proposition is that

collaborative relationships, specifically those defined in CPFR, can benefit the Air Force supply chain.

3. As a general rule, your tentative definition of the unit of analysis (and therefore the case) is related to the way you have defined your initial research question (Yin, 2003:23).

This thesis' unit of analysis is the question, "What opportunities exist between Depot Maintenance, Regional Supply Squadron (RSS), and Operational Bases for implementation of the CPFR processes?" The investigative questions are designed to collect information about the unit of analysis.

4. and 5. These components foreshadow the data analysis steps in case study research, and a research design should lay a solid foundation for this analysis (Yin, 2003:26). We must be able to take the data and literature collected and draw hypotheses and conclusions based on such.

Data Collection

Although some relevant data concerning collaborative partnerships was collected during the literature review phase, answering the investigative questions required interviews with and observations of key players in the Air force supply chain. Firstly, the researcher visited the Depot Maintenance facilities at Robins AFB, Warner-Robins, Georgia. He spent two days with the Item Manager, who deals directly with the component repair line and ACCRSS, and Program Manager, who has an overall view of

the system. Secondly, the researcher visited the ACCRSS facilities at Langley AFB, Virginia. There, he spent two days with the Equipment Specialists, who deal directly with the Item Manager at Depot and with the final customers at base level. Finally, the researcher spent two days visiting an Operational Base at Seymour-Johnson AFB, Goldsboro, North Carolina. At SJAFB, he visited with significant squadrons involved in the ordering and repairing of relevant components. All of the aforementioned key players take part in the daily workings in which the research is ultimately interested.

The researcher remained true to Yin's case study approach of the open-ended interview. He asked key respondents about the facts of the matter as well as their opinions about the events (Yin, 2003:90). The interview was non-standardized due to the changing setting of the interview. Open-ended questions were asked to key respondents about their input into and view of the overall picture. The virtue of the open-ended question is that it does not force the respondent to adapt to preconceived answers...they can express their thoughts freely, spontaneously, and in their own language (Frankfort-Nachmias and Nachmias, 1996:254).

Research Design

A research design is the logic that links the data to be collected (and the conclusions to be drawn) to the initial questions of the study (Yin, 2003:19). In addition, the development of case study designs needs to maximize four conditions related to

design quality: construct validity, internal validity, external validity, and reliability (Yin, 2003:19). These four conditions are outlined in Table 9, Case Study Tactics (Yin, 2003:19).

Table 9. Case Study Tactics

Tests	Case Study Tactic	Phase of the Research in which Tactic Occurs
Construct Validity	<ul style="list-style-type: none"> - Use multiple sources of evidence - Establish chain of evidence - Have key informants review draft case study report 	<ul style="list-style-type: none"> - Data collection -Data collection - Composition
Internal Validity	<ul style="list-style-type: none"> - Do pattern-matching - Do explanation-building - Address rival explanations - Use logic models 	<ul style="list-style-type: none"> - Data analysis - Data analysis - Data analysis - Data analysis
External Validity	<ul style="list-style-type: none"> - Use theory in single-case studies - Use replication logic in multiple-case studies 	<ul style="list-style-type: none"> - Research design - Research design
Reliability	<ul style="list-style-type: none"> - Use case study protocol - Develop case study database 	<ul style="list-style-type: none"> - Data collection - Data collection

(Yin, 2003)

Furthermore, Leedy and Ormrod address the subjects of validity and reliability: the validity of a measurement instrument is the extent to which the instrument measures what it is supposed to measure (2001:98) and the reliability of a measurement instrument is the extent to which it yields consistent results when the characteristic being measured hasn't changed (2001:99).

Construct Validity

Construct validity is the extent to which an instrument measures a characteristic that cannot be directly observed but must instead be inferred from patterns in people's behavior (Leedy and Ormrod, 2001:98). Observations and interviews with subject matter experts allowed the researcher to draw conclusions using this validity.

Internal Validity

Internal validity is the extent to which its design and the data that it yields allow the researcher to draw accurate conclusions about cause-and-effect and other relationships within the data (Leedy and Ormrod, 2001:104). Observations and interviews with subject matter experts also allowed the researcher to draw conclusions using this validity.

External Validity

External validity is the extent to which its results apply to situations beyond the study itself—in other words, the extent to which the conclusions drawn can be

generalized to other contexts (Leedy and Ormrod, 2001:105). Using this validity, perhaps the hypotheses concluded in this thesis may be applied to other sections of Air Force logistics.

Reliability

Reliability is the extent to which it yields consistent results when the characteristic being measured hasn't changed (Leedy and Ormrod, 2001:99). In an effort to increase reliability, the researcher attempted to maintain a chain of evidence (Yin, 2003:105). By maintain a chain of evidence, he was able to address each investigative question to multiple sources, and then compare the answers for similarities and differences.

Summary

This chapter presented the research methodology chosen for this thesis. The chapter began by re-addressing the problem statement, the research question, and finally the investigative questions. It then described the research method used as qualitative in nature, and also described the qualitative research method chosen as a case study. From

there, data collection was focused upon, and the chapter concluded by addressing the criteria for establishing trust and confidence within the research process. The following chapter documents the results of the researcher's methodology.

IV. History and Life of the MPDP

Chapter Overview

The purpose of this chapter is to present a case study narrative of a selected NSN. The asset chosen for assessment is NSN 1270-01-384-1108, better known as the F-15E Eagle Multipurpose Display Processor (MPDP). It will essentially cover the life of the MPDP—from procurement, to active use, to the eventual phasing out of the asset.

History of the MPDP

The F-15 Eagle was borne out of necessity in the early 1970s. The United States was faced with confronting a new generation of Soviet combat aircraft, while fighting a war in Vietnam with antiquated F-4 Phantom IIs. The basic objective of the F-15 program was, according to Major General Benjamin N. Bellis, F-15 System Program Director, to efficiently acquire a high-performance, extremely agile fighter aircraft capable of gaining and maintaining air superiority through air-to-air combat (Gething, 1983:4). First flown on July 27, 1972, the Eagle began entering the USAF inventory on November 14, 1974 and gave the Air Force precisely what the good General wanted. It was the first U.S. fighter to have engine thrust greater than the normal weight of the aircraft, allowing it to accelerate while in a vertical climb; this, combined with low

aircraft weight compared to wing area, made the Eagle highly maneuverable (National Museum of the United States Air Force, 2004).

McDonnell Douglas won the bid to produce the Eagle and has produced it in single-seat (F-15A) and two-seat (F-15B) versions. Manufacture of the initial production versions totaled 365 F-15As and 59 F-15Bs for the USAF, and 19 F-15As and two F-15Bs for Israel (Green and Swanborough, 1994:371). McDonnell Douglas upgraded the avionics, the external fuel tanks, and engines in 1979 and thus created the C and D models. Four hundred and nine F-15Cs and 61 F-15Ds were delivered to the USAF, 18 F-15Cs and 8 F-15Ds were delivered to Israel, and 46 F-15Cs and 16 F-15Ds were delivered to Saudi Arabia. As mentioned previously, the Eagle was designed for air-to-air superiority.

Although the slogan of the F-15's original design team was "Not a pound for air-to-ground," the F-15 has long been recognized as having superior potential in the ground attack role. As the first F-15s were designed to replace the aging F-4s, the new Eagle was almost certainly needed to replace the General Dynamics F-111 Aardvark (Dorr and Donald, 1990:207). Derived from the basic F-15D, the F-15E Strike Eagle was created to perform the dual role of both air-to-air and air-to-ground superiority. Featuring 60% structural redesign, the F-15E was developed to perform high ordnance payload, long-range, deep interdiction air-to-ground missions by day or night, in addition to an air superiority role, maximum weapons load being 24,500 pounds (Green and Swanborough, 1994:371). Again, numerous upgrades were made to the F-15D. The most outstanding upgrades were the conversion of the back seat to support a Weapons Systems Officer

(WSO) to operate weapons delivery systems, Conformal Fuel Tanks designed to remain on the aircraft (non-jettison) for longer bombing missions, many additional bomb and missile pylon positions, improved engines, and ,of course, a superior avionics package (Baugher, 2004).

The previous editions of the Eagle have enjoyed huge success in their respective mission, air-to-air. However, with the advent of the new air-to-ground mission, the new equipment was a necessity. In particular, the avionics package in the F-15E is more of a replacement package than an upgrade. The F-15A electronics suite featured a Hughes AN/APG-63 X-band coherent pulsed-Doppler radar set with look-down/shoot-down capability (Baugher, 2004). It had several different air-to-air modes with the pilot selecting ranges between 10 to 200 miles, usually in situations determining which weapon, gun or missile, would be used, but also in various radar mapping modes.

Data from the APG-63 radar is processed digitally and fed to an IBM CP-1075 central computer (Baugher, 2004). Information is then displayed to the pilot on either the Honeywell Vertical Situation Display (VSD) or on the AVQ-20 Heads-Up Display (HUD). The VSD is a cathode ray tube (CRT) mounted in the upper left dashboard of the control panel and is used primarily in the long-range phase of an engagement, displaying a cleaned up radar picture and presenting target data such as altitude, IFF return, ground speed, etc. (Baugher, 2004). At shorter range and in actual combat, the HUD is generally used, which combines target information with vital aircraft performance figures. Figure 8, F-15A Cockpit, provides a view of the early versions of the F-15 cockpit (gra.midco.net, 2004).



Figure 8. F-15A Cockpit (gra.midco.net, 2004)

Compared to the F-15A, significant improvements were made to the electronics suite of the F-15C. The AN/APG-63 radar of the F-15C was equipped with a Programmable Signal Processor (PSP) which is a high-speed, special-purpose computer that controls the radar modes through software rather than through a hard-wired circuit. This allows much more rapid switching of the radar between different modes for maximum operational flexibility. The use of the PSP also paved the way for the modification of the AN/APG-63, and later to the AN/APG-70 radar, to make it capable of carrying out radar mapping in a synthetic aperture mode. The AN/APG-70 was designed

for greater reliability and easier maintenance. Gate array technology enables the AN/APG-70 to incorporate modes not available in earlier radars while providing greatly enhanced operational capabilities in other modes (Raytheon, 2004). Historically, such imagery delivered by these systems had to be processed after the mission was over on the ground by large main frame computers because airborne equipment was too slow to produce images in real time. The new imagery improve mapping details and provides an overhead view of the target to the pilot as if he were flying directly over the target, even though he may be as much as a hundred miles away. As can be seen in Figure 9, F-15C Cockpit, little change was made in the F-15C cockpit (gra.midco.net, 2004).



Figure 9. F-15C Cockpit (gra.midco.net, 2004)

As in the late model F-15D, the F-15E continued to use the advanced AN/APG-70 radar for radar mapping and to perform its primary mission—air-to-ground attacks. However, now there were new issues. As mentioned previously, the F-15E has provisions for a rear-seater, or WSO. Many new systems and instruments were incorporated in the Strike Eagle. Figure 10, F-15E pilot and WSO cockpits, details such (gra.midco.net, 2004).



Figure 10. F-15E Pilot and WSO Cockpits (gra.midco.net, 2004)

As is clearly visible from the figures above, the instrumentation is much more sophisticated in the F-15E than its predecessors. Most notable is the addition of the cathode ray tube (CRT) flat panel displays, or Multipurpose Color Displays (MPCD) and Multipurpose Displays (MPD). No longer are the analog gauges utilized; and with that advance in technology, there must be a way to get the needed information formatted for

presentation on the HUD, MPCD, and MPD. The MIL-STD 1553 Digital Data Bus provides the pathway for such information.

At the heart of the data bus is the bus controller, in this case the Very High-Speed Integrated Circuit (VHSIC) Central Computer (VCC). The bus controller is the terminal that initiates information transfers on the data bus by sending commands to the remote terminals which reply with a response. The bus controller is often referred to as the “traffic cop” of the bus, deciding ultimately what information goes where. The VCC also does all of the computations for aircraft navigation, weapon delivery and control, and controls the system displays using information received from peripheral equipment (TO 1-F15E-2-31GS-00-1:40-1). As can be witnessed in Figure 11, F-15E Avionics Architecture, the VCC has control of all components residing on the data bus (Panarisi, 2001:31). It doesn’t, however, interface with the displays in the cockpit; that is the job of the MPDP.

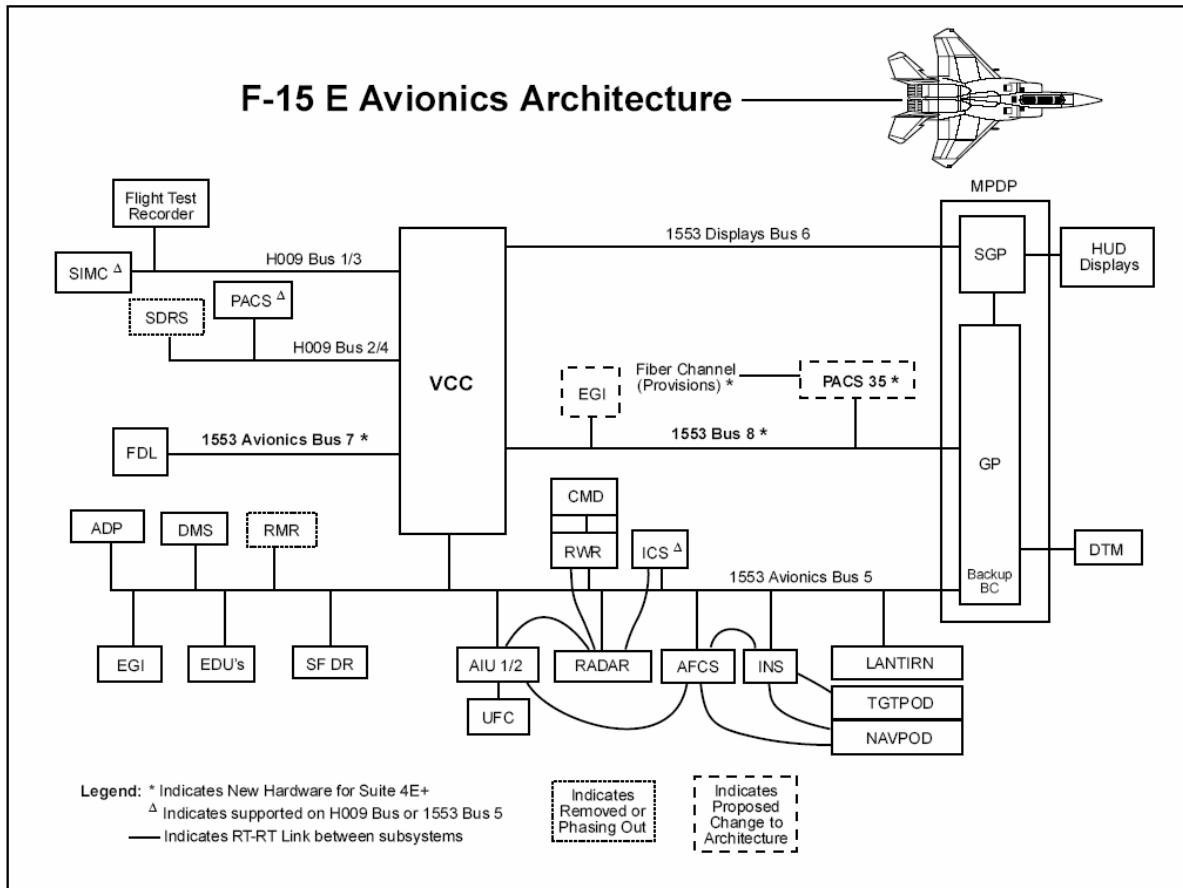

Figure 11. F-15E Avionics Architecture

(Panarisi, 2001)

The Strike Eagle provides integrated displays and controls operating on the data bus—a Multipurpose Display System consisting of the MPDP, left rear MPD, right rear MPD, left MPD, right MPD, left rear MPCD, right rear MPCD, forward MPCD, and the HUD (TO 1-F15E-2-31GS-00-1:Table 11-1). The MPDP is a multiple channel analog and digital processor that provides the processing, system timing, and operational coordination for the multipurpose display system (TO 1-F15E-2-31GS-00-1:11-1) and also performs a dual role as a Backup Bus Controller in the event of a VCC failure. The

MPD provide a monochromatic format on a 6 X 6 inch display screen; the MPCD provide a mono-chromatic or multicolor format on a 5 X 5 inch display screen. The HUD provides navigation and weapons data. All information displayed on the MPD, MPCD, and HUD is controlled by the MPDP; therefore loss of the MPDP results in loss of all displays. Figure 12, F-15E Multipurpose Display System Block Diagram, details precisely the functions of the MPDP during both normal and backup modes (TO 1-F15E-2-31GS-00-1:11-18).

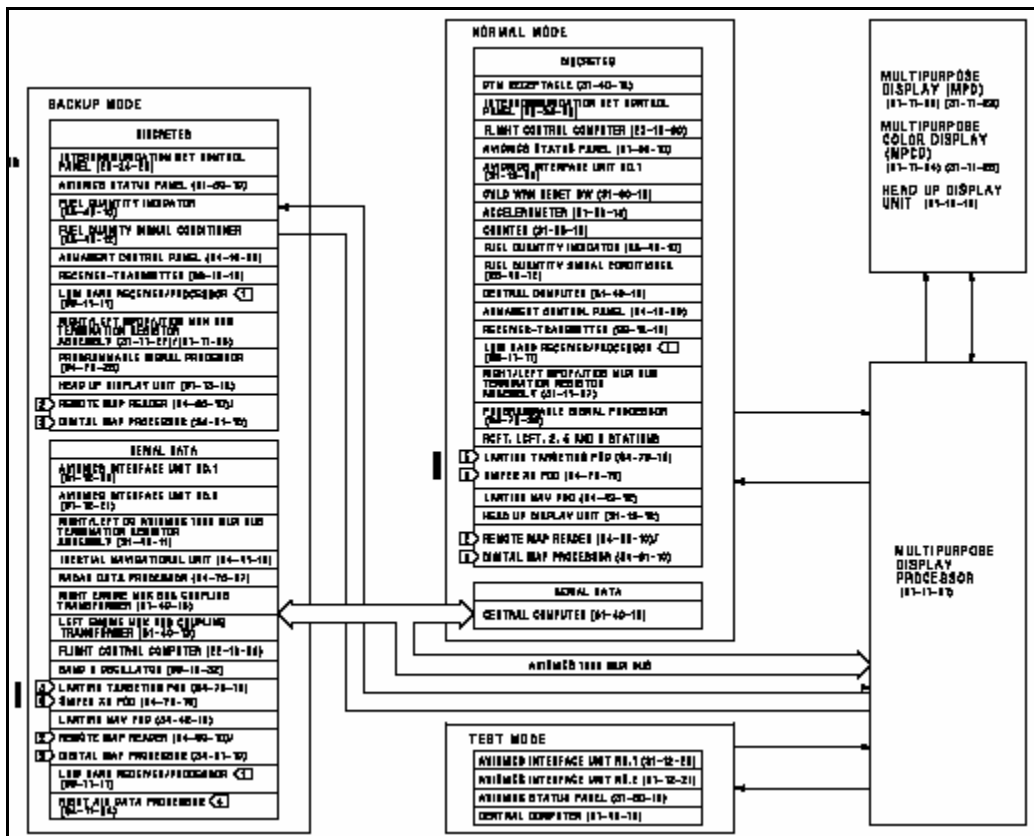

Figure 12. F-15E Multipurpose Display System Block Diagram
(TO 1-F15E-2-31GS-00-1)

As stated previously, the MPDP is a multiple processor symbol generator that simultaneously drives eight displays—four MPD, three MPCD, and the HUD. The MPDP produces and overlays symbology (graphic symbols and alphanumerics) on the MPD and MPCD by raster/stroke methods (TO 1-F15E-2-31GS-00-1:11-37). The stroke method is primarily used on the HUD for bright sunlight; while the raster method is used on all displays for video. A separate display channel drives each display individually to ensure further operation if one display ceases to function. Display output data produced by the MPDP may be made up of either stroke written symbology (only), monochrome and color rasters, or hybrid with monochromatic raster symbology (TO 1-F15E-2-31GS-00-1:11-37). Again, if the MPDP becomes inoperative, there are no displays on the MPD, MPCD, or the HUD.

Life of the MPDP

The MPDP (and VCC) were original equipment in the initial Strike Eagles. They were developed by Honeywell through Boeing and consisted of 1980s technology. The previous versions of the F-15 had rudimentary versions of the VCC and MPDP to control what limited digital information, displayed primarily on the HUD, they possessed. The majority of the instrumentation was analog in nature and displayed on analog gauges. The VCC replaced the analog and digital processors and the MPDP replaced the data processor seen in Figure 13, F-15C Avionics (Gething, 1983:33).

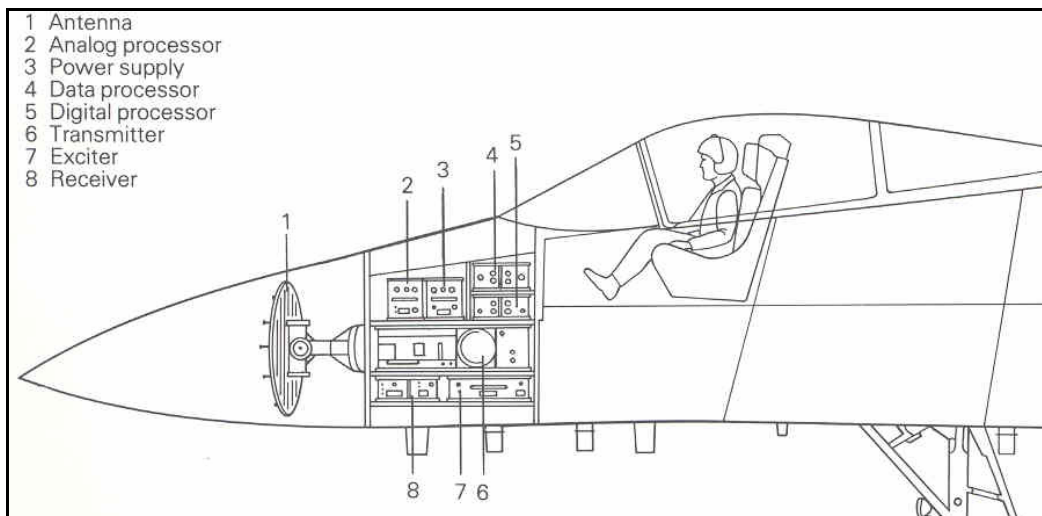

Figure 13. F-15C Avionics

(Gething, 1983)

The MPDP as a Line Replaceable Unit (LRU) consists primarily of 44 circuit card assemblies, four power supplies, and a 26 layer motherboard, once more, running on 1980s technology. Of the components listed above, 23 of the 44 circuit card assemblies, all four power supplies, and the motherboard are considered Shop Replaceable Units (SRU). However, due to the age of the aircraft, there are precious few spares available, and backordering the LRU, or even the SRU to repair the LRU, can sometimes take weeks. Figure 14, F-15E MPDP Location, shows the location of the MPDP under access door 3L, just aft of the radome.

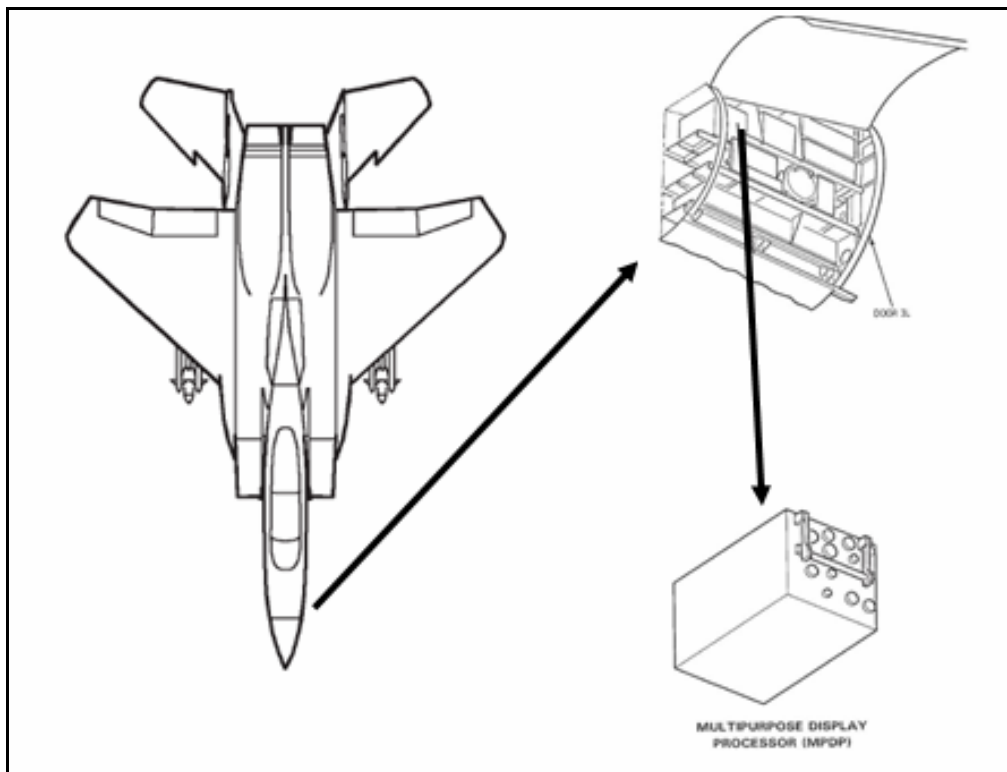

Figure 14. F-15E MPDP Location (TO 1-F15E-2-31GS-00-1)

As with most original equipment on a new aircraft, there were problems in the beginning for the MPDP. It was branded a bad performer and given the strictest attention. This came at a time when there were no “open system contracts” with outside sources. Open systems approaches are those which use the insertion of commercially based, upgradeable hardware technology. These are widely used today and, as a matter of fact, the MPDP replacement, the Advanced Display Core Processor (ADCP), is one such contract. We will speak more of the ADCP in the following chapter.

There were issues, as one could expect in *normal* operating conditions with new technology, but this particular piece of equipment was going over 1,800 miles per hour in the nose of the Strike Eagle. Most of the malfunctions dealt with faulty solder joints, etc. as a result of the extreme environment. Initially, of course, each F-15E was equipped with one MPDP and the program was spared healthily due to its initial design and resultant malfunctions—227 (one in each aircraft) and 92 spares. Since there was no prior MPDP, there was no Mean Time Between Demand (MTBD) data on which to base the spares calculation. No one the researcher contacted was able to give a sufficient answer on how the spares were calculated. One would think 92 spares was adequate (143%), but we must remember, this was state-of-the-art technology and prone to failures.

According to AFMCMAN 23-1, Requirements for Secondary Items, the Air Force uses many aspects in calculating the spares required. Contained in the calculation are features such as projected operating requirements, projected condemnations, projected lead times, projected pipeline requirements, projected repair cycle requirements,

projected safety stock level, projected additive requirements, and projected War Reserve Materiel (WRM) and Readiness Spares Packages (RSP) requirements (AFMCMAN 23-1, 2004:39-40). The USAF is currently using the Requirements Management System (RMS) D200 to calculate such things, but has forever had systems in place for estimating spares requirements. Figure 15, Typical USAF Logistics Pipeline, shows a typical USAF logistics pipeline covering all facets described above (O'Malley, 1996:3).

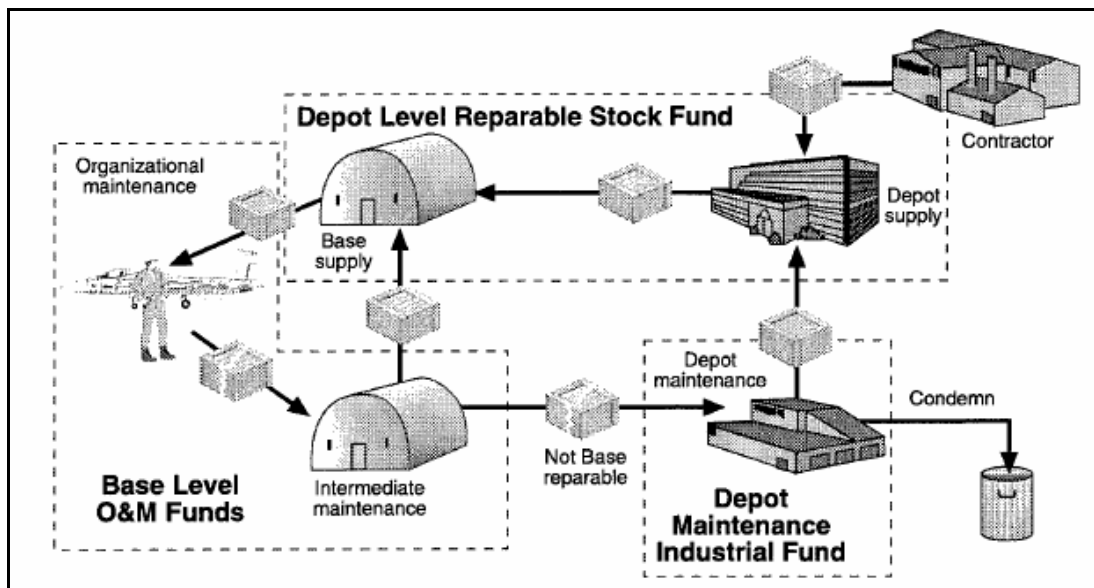

Figure 15. Typical USAF Logistics Pipeline (O'Malley, 1996)

It is important to remember the MPDP is mandatory for flight, and the Quantity Per Aircraft (QPA) for the MPDP is one. Therefore, if an MPDP or an SRU for the MPDP is backordered, the aircraft is grounded. It is also relevant to note the MPDP is scheduled for replacement by the aforementioned ADCP in short order. This removes the MPDP from the buy aspect covered in Section 1.8 Initial and Follow On Spares in

AFMCMAN 23-1 (2004:42). Table 9, MPDP Projected Requirements, details the projected MPDP requirements (F-15 Systems Program Office Website, 2005). December 2008 is the date when all Strike Eagles should be modified with ADCP, and the process begins anew.

Table 10. MPDP Projected Requirements

Date	QPA	Application %
Dec-87	1	100
Dec-04	1	100
Mar-05	1	100
Jun-05	1	100
Sep-05	1	100
Dec-05	1	96
Mar-06	1	89
Jun-06	1	82
Sep-06	1	76
Dec-06	1	67
Mar-07	1	57
Jun-07	1	48
Sep-07	1	38
Dec-07	1	29
Mar-08	1	20
Jun-08	1	11
Sep-08	1	3
Dec-08	1	0

(F-15 Systems Program Office Website, 2005)

Summary

This chapter presented the history of the MPDP. The chapter began by addressing the needs of the USAF and the eventual purchase of the F-15E Strike Eagle. It then described the various components associated with the Avionics, and more specifically the Instrumentation, System. From there, it covered the life of the MPDP—from procurement, to active use, to the eventual phasing out of the asset. The following chapter documents the results of the researcher’s case study.

V. Tracking the MPDP through the Supply Chain

Chapter Overview

The purpose of this chapter is to present findings discovered by the researcher during his visit to three key areas of the USAF pipeline/supply chain. The first visit was to an operational base, Seymour-Johnson Air Force Base, Goldsboro, North Carolina. While there, he gathered information from members of the 4th Fighter Wing concerning processes regarding the MPDP. The next visit was to ACCRSS, Langley Air Force Base, Langley, Virginia where he gathered more data from the Command-level supply aspect. Lastly, he traveled to Robins Air Force Base, Warner-Robins, Georgia, where he communicated with the Item Manager, Program Manager, Depot Level Maintenance, and others regarding their involvement with the MPDP.

Overall MPDP

These three stops are classic examples of a USAF logistics pipeline. Typically, the operational base is supported by a RSS, who in turn is supported by the depot. Ploos van Amstel states a pipeline is the physical goods flow from the supplying organization to its customer (1990:4). That may have been true in 1990, but in today's market other aspects come into play. The best definition this researcher happened upon was the one

posited by Mentzer, et al stating a supply chain is a set of three or more entities (organizations or individuals) directly involved in the upstream and downstream flows of products, services, finances, and/or information from a source to a customer (2001:4).

As stated previously, the MPDP is an exceptional piece of equipment, solely residing on the F-15E Strike Eagle. Figure 16, F-15 Operating Locations, shows the location of all jets in the inventory (F-15 Systems Program Office Website, 2005). Of the 730 total (USAF) F-15s, 224 are Strike Eagles. Almost half of those, 96, are located in Seymour-Johnson AFB, home of the 4th Fighter Wing. The majority of the rest are positioned around the world at the 3rd Wing, Elmendorf AFB, Alaska, the 48th FW, Lakenheath AFB, United Kingdom, and the 366th FW, Mountain Home AFB, Utah.

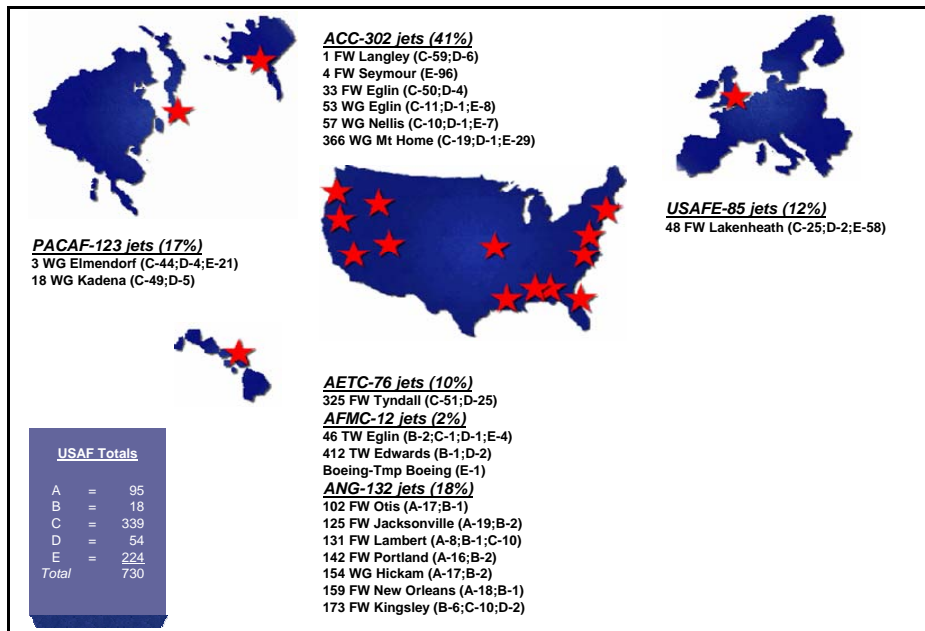

Figure 16. F-15 Operating Locations

(F-15 Systems Program Office Website, 2005)

Most importantly, the goal of the Expeditionary Aerospace Force concept is to rely on rapidly deployable, immediately employable, highly effective and flexible air and space packages to flexibly serve the role that a permanent forward presence formerly played in deterring and quickly responding to aggression (Peltz, et al, 2000:3). And, with the Air Expeditionary Force notion of light, lean, and lethal, many of these aircraft are being deployed to forward locations in support of national interests. Needless to say, what was once a huge pipeline has now become even longer. Not only has the pipeline grown the flying hours (OPSTEMPO) have increased. In a 1998 article regarding such OPSTEMPO, Colonel Irving Halter, 1st Fighter Wing Operations Group Commander, stated:

“In 1997, the wing sent 16 F-15s to Saudi Arabia...and over the course of 6 months, they accumulated an average of 485 hours each ... ordinarily, it would take an F-15 more than a year and a half to fly that much... we are finding things breaking on the jets that we had not predicted...”
(Matthews, 1998:13)

The researcher has cited, on numerous occasions, the MPDP is airframe specific to the F-15E. Before we examine the part itself, we will look at how vital it is to the aircraft and more specifically the metrics that the aircraft is judged upon. Perhaps the most important of these metrics is the Mission Capable Rate (MCR). The MCR combines failure frequency with repair efficiency, and thus is dependent on reliability, maintainability, and supply; for example, if a part needed to repair a failed component is not available, then the resulting logistics or supply delay adds to the down time, over and above the time needed to replace the component once available (Balaban, et al,

2000:1036). Figure 17, Historical F-15E Mission Capable Rates, shows a look at roughly the last eight years of MCR basing its success on a USAF standard of 80%. One can see the Strike Eagle enjoyed high MCR initially, followed by a steady decline over the next few years, a sharp decline around Desert Shield/Storm, and a slight recovery (albeit mainly under standards) of late (F-15 Systems Program Office Website, 2005).

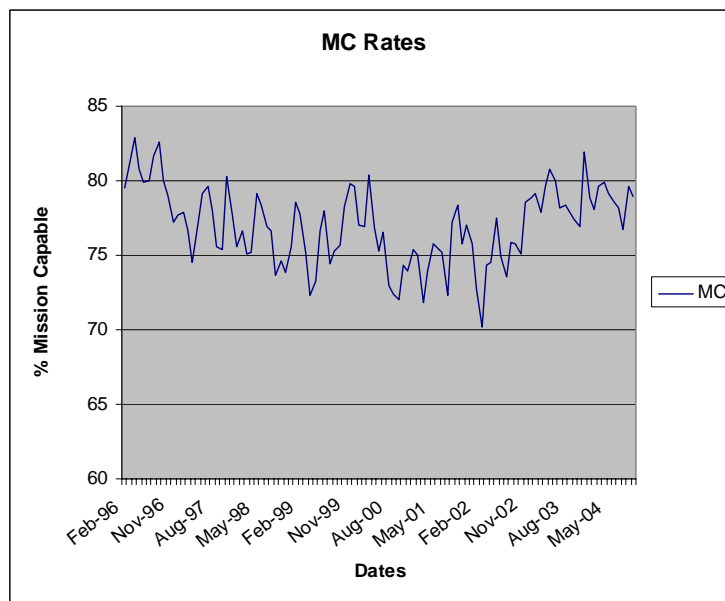

Figure 17. Historical F-15E Mission Capable Rates
(F-15 Systems Program Office Website, 2005)

Two other key metrics worthy of note are the Total Not Mission Capable Supply (TNMCS) and Total Not Mission Capable Maintenance (TNMCM). The TNMCS rate describes the percentage of aircraft not fully mission capable due to the unavailability of spare parts (Oliver, et al, 2001:29). Oliver, et al identify factors such as component reliability and demand, logistics operation factors such as proper mix and level of

inventory, component repair times, order and ship time (O&ST), diminishing manufacturing sources, material shortages, and inventory forecasts (2001:29).

Likewise, the TNMCM rate describes the percentage of aircraft not fully mission capable due to one or more maintenance issues (Oliver, et al, 2001:31). Oliver, et al also point out that factors such as manning, experience, retention, increased inspections, modification to aging aircraft, break rates, cannibalization, increased man-hours, OPSTEMPO, and aircraft maintenance management policy changes are key in this measurement (2001:31).

Figure 18, Historical F-15E Total Not Mission Capable Supply/Maintenance Rates, shows a look at roughly the last eight years of TNMCS/M basing its success on a USAF standard of 10% and 14%, respectively (F-15 Systems Program Office Website, 2005).

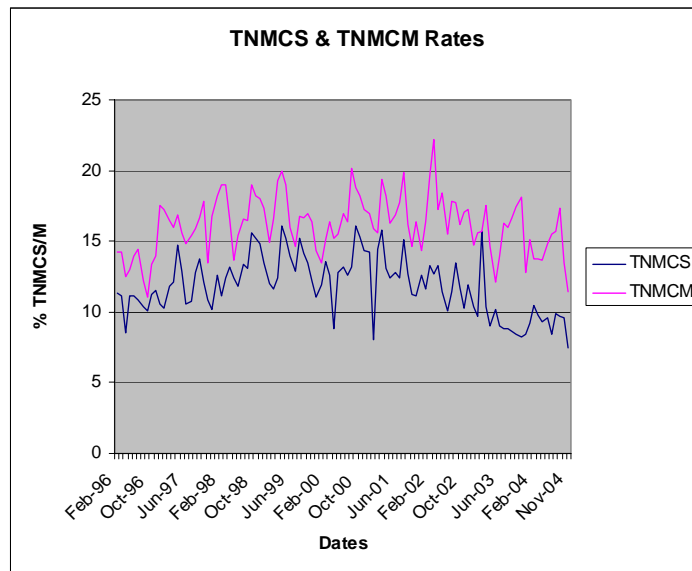

Figure 18. Historical F-15E Total Not Mission Capable Supply/Maintenance Rates (F-15 Systems Program Office Website, 2005)

One of the primary reasons for underwhelming metrics and poor performance of an aircraft is its reliability on parts. An aircraft will experience downtime because of essentially two types of aircraft parts—expendable and repairable. Expendable parts are those usually of low cost and not worthy of being repaired. These are, more often than not, on hand and easily accessible. Repairable parts, on the other hand, are high cost items which can be repaired locally, in some cases, or sent away to the Depot for overhaul. In both cases, if the part is not readily available, the aircraft is grounded, and the part is ordered in a MICAP (Mission Capable) status.

MICAP procedures are used to secure materiel needed to repair mission essential equipment of the highest priority; the MICAP system provides a method of obtaining the kinds of items required by AF organizations to maintain mission capability (AFMAN 23-110, 2005:Volume 2, Part 2, Chapter 17, 17-1). Prior to submitting a MICAP request, base Supply personnel must verify that all possible assets at base-level are depleted.

They, and Maintenance personnel, should determine whether a substitute item can be used; search for items issued for time change and Time Compliance Technical Order kits; check bench stocks; check War Readiness Materiel/Readiness Spares Packages, Special Purpose Recoverables Authorized Maintenance or supply point details; check items listed on component parts/repair lists; consider cannibalization or items due-in from maintenance not awaiting parts; assess the possibility of priority repair; determine if a next higher assembly is available or cannibalization is feasible, and consider diverting materiel in storage awaiting installation (AFMAN 23-110, 2005:Volume 2, Part 2, Chapter 17, 17-2).

MICAPs are very important items in the Air Force logistics world and provide us with some excellent metrics. One way is back taking the MICAP numbers and “racking and stacking” them for assessment. Figure 19, Recent F-15E Top 100 MICAP Drivers by System, is one of the most note-worthy. It provides a thirteen-month timeframe of data and a snapshot of the diverse systems on the Strike Eagle. It represents a computation of the time a specific system spends in Top 100 MICAP status and compares it with supplementary systems on the aircraft. These percentages are derived by adding all of the MICAPs currently on the Top 100 MICAP list for a particular system and dividing the sum by the total number of Top 100 MICAPs for the month. The Fire Control System, of which the MPDP is an essential component, has remained an enduring fixture on the top of the list (F-15 Systems Program Office Website, 2005).

SYSTEMS	Nov-03	Dec-03	Jan-04	Feb-04	Mar-04	Apr-04	May-04	Jun-04	Jul-04	Aug-04	Sep-04	Oct-04	Nov-04
Fire Control	18.9%	14.4%	13.8%	16.2%	19.8%	13.3%	15.7%	12.6%	16.5%	12.2%	15.3%	15.5%	16.0%
Flight Controls	7.1%	8.8%	20.5%	20.4%	18.2%	16.5%	20.3%	18.0%	18.9%	13.1%	12.3%	13.0%	12.2%
Airframe	8.2%	11.2%	6.2%	6.5%	7.6%	11.6%	11.6%	7.2%	6.6%	6.9%	8.2%	9.7%	11.7%
Secondary Power	1.3%	1.4%	1.5%		1.0%	1.1%	1.5%	3.2%	0.4%	8.8%	13.3%	15.6%	11.4%
Radio Navigation	4.8%	4.6%	2.0%	1.8%	3.6%	4.2%	5.0%	9.8%	7.0%	11.2%	11.6%	11.6%	11.1%
Fuel System	7.0%	10.7%	8.9%	7.7%	8.9%	5.7%	4.5%	3.2%	5.8%	3.2%	2.8%	5.0%	6.5%
AutoPilot	6.5%	4.7%	4.2%	2.9%	3.8%	2.7%	1.0%	1.5%	1.9%	1.4%	1.4%	2.1%	5.8%
Electrical Power Supply	0.6%	2.8%	2.2%	2.5%	3.2%	5.2%	3.9%	3.0%	2.0%	3.9%	2.5%	2.6%	5.3%
ECS	13.2%	5.7%	2.0%	1.4%	0.6%	4.9%	6.7%	12.2%	14.1%	19.4%	11.4%	7.6%	3.8%
Landing Gear	9.1%	11.8%	17.5%	15.3%	8.5%	7.6%	12.8%	9.9%	8.2%	3.7%	3.5%	1.8%	3.8%
Hydraulic/Pneum Power	1.6%	0.9%	0.9%	1.2%	1.4%	1.4%	1.1%		1.6%	1.5%	1.8%	1.8%	2.9%
Instruments	8.2%	6.0%	4.2%	3.4%	4.3%	4.6%	5.7%	6.2%	6.1%	5.8%	4.0%	3.6%	2.0%
Guidance/Flt Ctrls	1.0%	2.5%	3.2%	8.5%	12.3%	13.9%	5.5%	3.2%	3.2%	2.7%	2.9%	1.7%	1.7%
Lighting System	2.8%	1.9%	1.1%	1.5%				0.4%	0.8%	1.5%	1.7%	1.2%	1.8%
Cockpit	1.7%	1.6%	3.0%	2.4%	1.9%	1.2%	0.7%	2.3%	2.1%	2.3%	1.6%	0.8%	0.9%
Oxygen			0.5%	0.9%	0.7%	0.4%	1.3%	0.5%	0.7%		1.9%	1.9%	0.6%
UHF Communications	1.2%	1.1%	1.9%	2.2%		0.6%		2.0%	0.8%	0.8%	1.9%	0.8%	0.6%
ECM	1.4%	4.7%	4.2%		1.6%	0.4%	0.5%	1.0%	0.4%	0.4%	0.7%		0.4%
Weapons Delivery	1.9%	3.2%	1.2%	3.0%	4.3%	3.2%	0.8%	2.7%		0.4%	0.8%	0.9%	0.3%
Computer/Data Display	1.3%					0.4%	0.6%		0.4%	0.6%		0.6%	
Radar Navigation													
IFF			0.5%										
Emergency Equipment	0.5%												
Malfunction Equipment								0.5%	0.6%	0.4%			

Figure 19. Recent F-15E Top 100 MICAP Drivers by System
(F-15 Systems Program Office Website, 2005)

As previously stated, one of the major reasons the Fire Control System is a mainstay on the Top 100 MICAP Drivers by System is the MPDP. Figure 20, Recent F-15 Top 10 MICAP Drivers, shows the MPDP is the number one F-15E specific piece of equipment—the Fighter Data Link, Power Take-off Shaft, Rudder Actuator, Air Navigation Multiple Indicator, and Multipurpose Color Display are A-D model assets. While this is a look at the last six months of data in 2004, the researcher was informed by everyone involved it is not an enigma. The MPDP has been on or near the top of the list for many months (reasons to come in the following paragraphs) and its get-well date is, in fact, the date all F-15Es are equipped with the replacement ADCP (F-15 Systems Program Office Website, 2005).

MICAP HOURS						MICAP RANK						NOUN	SYSTEM	Cum Hrs FY 04
Jun-04	Jul-04	Aug-04	Sep-04	Oct-04	Nov-04	Jun-04	Jul-04	Aug-04	Sep-04	Oct-04	Nov-04			
9575	11529	21010	19598	20539	20242	2	2	2	2	2	1	FDL	Radio Navigation	40,781
1207	2686	14694	21513	27833	16719	41	18	4	1	1	2	PTO SHAFT	Secondary Power	44,552
15054	16210	16419	17066	13562	15146	1	1	3	3	3	3	RUDDER ACT	Flight Controls	28,708
5038	6579	2751	5003	9450	7894	5	5	15	5	4	4	ANMI	Fire Control	17,344
2063	2427	1550	1437	1367	5194	20	19	33	35	35	5	MPCD	Fire Control	6,561
4990	6849	3749	3666	4028	5096	6	4	8	8	7	6	MPDP	Fire Control	9,124
3122	4317	1914	1147	851	4137	10	11	21	51	68	7	LH MLG	Landing Gear	4,988
81	283		528	1757	3904	530	226		135	21	8	SERVO	Airframe	5,661
1028	481	1582	2459	2626	3837	50	139	31	15	11	9	GEARBOX	Secondary Power	6,463
59	188	1519	1200	2240	3710	654	290	35	45	13	10	CABLE ASSY	Electrical Power	5,950

Figure 20. Recent F-15 Top 10 MICAP Drivers

(F-15 Systems Program Office Website, 2005)

Now that we have explained some of the metrics and shown the recent history of the MPDP, we will delve into the information gathered by the researcher on his visits. Again, we will begin with the operational base, then on to ACCRSS, and finally conclude with a call upon the Depot.

Seymour-Johnson Air Force Base

Seymour-Johnson AFB (SFAFB) was selected for two reasons—proximity of the F-15E base to the researcher and the fact that it possesses nearly half of the USAF's assigned Strike Eagles. While visiting SJAFB, the researcher was able to engage several of the key players in the MPDP at base level. In this section, trips to the 4th Operations Support Squadron, the 4th Aircraft Maintenance Squadron (AMXS), the 4th Component Maintenance Squadron (CMS), and the 4th Logistics Readiness Squadron will be discussed.

4th Operations Support Squadron (4 OSS)

Before a single mission is flown at an operational base, much work has gone into the creation of the flying schedule; this was the reason for the researcher's first stop at 4 OSS. Air Force Policy Directive 11-1, Flying Hours Program, outlines the strategies for all in the Total Air Force—Active Air Force, Air National Guard, and the Air Force Reserve. It states the Air Force will plan the flying hour program based on peacetime, home station training requirements, execute its approved flying hour program to the maximum extent possible, and allocate resources to support its approved flying hour program (AFPD 11-1, 2004:1).

The Air Force Flying Hour Program consists of the flying hours necessary to train aircrews to safely operate their aircraft and sustain them in numbers sufficient to execute their core tasked mission (AFI 11-102, 2002:3). The Air Force Flying Hour Model provides the methodology and processes that MAJCOMs use to build their flying hour programs; this model determines the number of flying hours needed to attain and maintain combat readiness for all aircrews, test weapons and tactics, and fulfill collateral requirements (AFI 11-102, 2002:3).

The AFFHM is composed of 5 core elements: Force Structure, Aircrew Data, Requirements, Calculation, and Summary seen in Figure 21, Air Force Single Flying Hour Model. For operational flying units the relationship of these components expresses the mathematical description: force structure determines the number of pilots, pilots multiplied by requirements determine the number of flying hours; for formal training units the mathematical description is average daily student load multiplied by the average number of flying hours per student per day, multiplied by the number of training days determines the number of required student flying hours, which determines force structure (AFI 11-102, 2002:3).

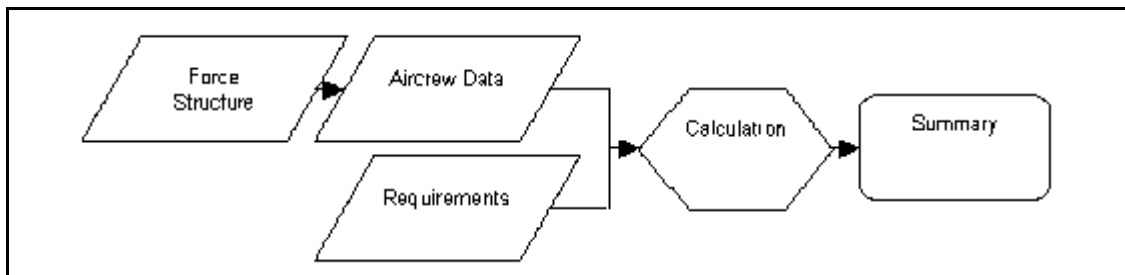

Figure 21. Air Force Single Flying Hour Model (AFI 11-102, 2002)

When the MAJCOM, in this case Air Combat Command (ACC), finalizes the flying hours calculated by the AFFHM, they are sent to the Wing operations controllers at each base. At this point, each Wing works its minuscule piece of the enormous Air Force flying hours pie. There they decide how many hours will be assigned, or contracted, to each squadron in the Wing. The contracts are between ACC and each operational base. They may be renegotiated quarterly, if you ahead or behind your sorties or hours, but this is not usually done. There is quite often a large push in September (end of fiscal Year) if behind, or numerous flying down days if ahead. The key, of course, is to try to stay on schedule.

After studying the attrition rates of the last three years, operations and maintenance are able to divide the entire schedule into monthly segments. This is then used by maintenance to create stability in their scheduling of Programmed Depot Maintenance, Phase Inspections, etc. The actual tail numbers of aircraft are not decided upon until the week before by the squadron maintenance scheduling sections. One such section is located in the 4th Aircraft Maintenance Squadron.

4th Aircraft Maintenance Squadron (4 AMXS)

4 AMXS directs all on-equipment maintenance for the largest F-15E Strike Eagle fighter wing in the Air Force, consisting of 96 aircraft; conducts tactical aircraft, avionics, engine, electrical, environmental, and weapons sub-system maintenance and munitions

loading for both qualification training of F-15E aircrews in day/night, all weather, air-to-air, and air-to-ground missions and in direct support of worldwide contingency operations (Seymour Johnson Air Force Base Home Page, 2004). On-equipment maintenance is any work done on the aircraft itself. Any maintenance on assets removed from the aircraft, to be worked in a back shop for example, is termed off-equipment.

With the pilot as the only exception, 4 AMXS is the final customer. It is there, ultimately, that parts are deemed flight-worthy or not. These malfunctioning parts can be found any number of ways. Multiple inspections are performed prior to and after each sortie, and the pilots themselves may identify a failure in a particular system and document in the aircraft forms for attention.

Following recognition of a faulty asset, a replacement part is placed on order. Regardless of the status of the part, expendable or repairable, it is routed through the 4 AMXS supply representative. The supply representative then verifies if the asset is expendable or repairable and places it on order in one of two systems. It can be ordered in CAMS (Core Automated Maintenance System, used primarily by maintainers) or SBSS (Standard Base Supply System, used by base supply personnel). CAMS is a database that stores all of the maintenance history data about each aircraft in the AF inventory, while SBSS takes the order and places a demand on the supply system. Fortunately, these two systems are electronically linked and ideally exchange information automatically.

Upon order, a priority code is placed on the request. In the requisitioning, movement, and issue of materiel, it is necessary that competing demands be identified

according to relative importance in order to issue the most effective management of logistics system resources (AFMAN 23-110, 2005: Volume 1, Part 1, Chapter 24, 24-3). The Uniform Materiel Movement and Issue Priority System (UMMIPS) establishes a series of two-digit numeric codes (01-15) to express the comparative significance of requisitions, known as priority designators. The priority designator entry entered for requisitions and related documentation is based upon a combination of factors which signify the mission of the requisitioner or the intended recipient (Force/Activity Designator) and the urgency of need or end use (Urgency of Need Designator) (AFMAN 23-110, 2005:Volume 1, Part 1, Chapter 24, 24-3).

Regardless of the priority, if the part is available on another aircraft, usually one already inoperative for another reason, it may be cannibalized. If so, the part is ordered against the broken aircraft and is recognized by 4 CMS personnel as a “soft (Memo) MICAP.” This results in a lower priority, since the aircraft is already down, and is not seen by anyone outside of the base level. If there are no aircraft to cannibalize (or the “Cann-birds” have already been relieved of said part) it results in a “hard MICAP.” This hard MICAP (in definition they are both MICAP, but one is a work-around) flags everyone in the Supply system. ACCRSS and the Item Manager are alerted and the search for the part begins in earnest.

It is important to remember, either type part, be it expendable or repairable, is a potential showstopper if deemed MICAP and not readily available. If expendable, the part is in effect disposed of; if repairable, the part is routed to the 4th Component Maintenance Squadron for analysis. The MPDP is a repairable asset.

4th Component Maintenance Squadron (4 CMS)

4 CMS accomplishes off-equipment aircraft maintenance on the wing's F-15E Strike Eagle aircraft; the squadron performs maintenance on propulsion, avionics, electronic weapon, and accessory systems in support of worldwide contingency operations (Seymour Johnson Air Force Base Home Page, 2004). They deal directly with their flight line maintenance counterparts regarding the faulty Line Replaceable Unit (LRU).

The malfunctioning component is routed to 4 CMS in hopes of a quick repair. When the part enters the door, the attached paperwork, or the maintenance/supply liaison them self, will alert the 4 CMS representative of its MICAP status. If 4 CMS wishes to double check the 4 AMXS request, they may run a query in CAMS to verify the document number against the NSN. However, in the case of the MPDP, everyone in the shop knows the NSN by heart—due to its constant MICAP condition.

Worthy of note is 4 CMS' exceptional Eagle Eye program. It is a local, historical database tracking all work accomplished on an asset. The database is web-based so any team member can easily access any report. Based on their self-assigned categories, they determine (in concert with AF needs) which components get worked first. The oldest document number in each of the following categories is worked first: Test Station Maintenance (if a test station goes down, no work can be accomplished), hard MICAP LRU, soft MICAP LRU, Routine LRU, and LRU from other locations.

LRU have what are called “Due In From Maintenance” (DIFM) days. A DIFM detail is established for a reparable item flowing through maintenance from the time of removal from the aircraft to its actual return into the supply system. This ensures the part returns quickly back into the system by punishing the repair facility for retaining the part too long. As a matter of fact, 4 CMS has sixty days to repair the part or they are charged with the carcass price (net cost with no repairs accomplished) of the asset. This is not only costly, but it is hugely frowned upon. The feeling is, why hold on to the part for so long? If you cannot repair it, get it back into the system so someone else can.

If they, indeed, cannot repair the part, it is known as “Not Repairable This Station” (NRTS) and is sent to the Depot for repair. Each maintenance section employs a DIFM monitor to track this metric daily. This monitor prints out a daily run and presents it to the Production Superintendent to monitor shop production. In consequence, in house work priorities may be altered if there is an old document number and part accumulating DIFM days.

When the LRU is deemed reparable on station, the component is troubleshot by avionics technicians. If a faulty subcomponent, or Shop Replaceable Unit (SRU), is discovered, the SRU is ordered in the exact same way as detailed above. If the SRU issues, the LRU is repaired and returned to the supply system. If not, the component is entered into AWP (Awaiting Parts) Status. This, in effect removes it from the watchful eye of the DIFM Monitor. However, it is now being tracked by an AWP monitor. Needless to say, AWP days result in the same outcome as DIFM days so they are both equally deficient.

The MPDP is a Three Level Maintenance (3LM) item as opposed to Two Level Maintenance (2LM). This simply means repairs can occur at essentially every level—Organizational (4 AMXS), Intermediate (4 CMS), and the Depot Repair Facility. Each level indicates the type of repair to be performed from simplest to most difficult. Organizational is the simplest and consists of minor repairs, cannot duplicate testing (CND), and calibration; intermediate repair is primarily testing and replacement of component parts; and Depot level are those repairs that could not be accomplished at the intermediate level and major overhauls (AFI 21-129, 1998:3). 2LM, the goal of the Air Force, for all intents and purposes eliminates the intermediate functions thereby reducing manpower, equipment, facilities, and mobility footprint.

Lastly, how often a component can be repaired by a base-level back shop is tracked in a metric called Percentage of Base Repair (PBR). PBR is calculated by adding the total components repaired and CND (Could Not Duplicate malfunction) and divide that by adding the sum of repaired and CND and NRTS (components deemed Not Repairable This Station, and routed to Depot). Figure 22, Recent 4 CMS MPDP Production, summarizes 4 CMS Received, Repaired, CND, and PBR rates (Stockwell, 2004). Also, interesting is the steady decline in the overall MPDP turned (either repaired or CND) over the last four years.

01-Jan-00 to 31-Dec-00						Overall
Nomenclature	Received	Repaired	CND	NRTS	PBR	Total Turned Per Month
MPDP	239	116	90	32	86.55%	17.17
01-Jan-01 to 31-Dec-01						Overall
Nomenclature	Received	Repaired	CND	NRTS	PBR	Total Turned Per Month
MPDP	208	90	102	13	93.66%	16
01-Jan-02 to 31-Dec-02						Overall
Nomenclature	Received	Repaired	CND	NRTS	PBR	Total Turned Per Month
MPDP	227	110	67	50	77.97%	14.75
01-Jan-03 to 31-Dec-03						Overall
Nomenclature	Received	Repaired	CND	NRTS	PBR	Total Turned Per Month
MPDP	176	97	51	28	84.09%	12.33
01-Jan-04 to 31-Dec-04						Overall
Nomenclature	Received	Repaired	CND	NRTS	PBR	Total Turned Per Month
MPDP	175	101	35	40	77.27%	11.33

Figure 22. Recent 4 CMS MPDP Production (Stockwell, 2004)

4th Logistics Readiness Squadron

In September 1999, the Chief of Staff directed a top-to-bottom evaluation of base-level logistics procedures. One of the four process focus areas was materiel management. The MAJCOMs agreed to integrate the wing-level materiel management processes into a single authority responsible for base-level supply and transportation functions...thus streamlining processes and eliminating overlapping functions (Zettler, 2001:8). In 2001, the Logistics Readiness Squadron was created by merging the old Supply and Transportation Squadrons with Logistics Plans Flight (a Wing-level function) into a single logistics squadron (Chapman, 2002:17).

The lead action officer for the creation and implementation of the new squadron said the goal was to find a single point of contact for expeditionary logistics and combat readiness capability (Lopez, 2002). She stated the goal was creating a single point of contact for distribution at the wing, so the Wing Commander could ask one person a question and that one person would know the order status, the movement status, and the warehousing status (Lopez, 2002).

The result of the *Program Action Directive (PAD) 02-05: Implementation of the Chief of Staff of the Air Force Direction to Establish a New Combat Wing Organization Structure* gave the Chief and the local Wing Commander just what they wanted. Figure 24, LRS Structure, outlines the present Logistics Readiness Squadron. The primary interest for the research dealt with the supply functions located in the Distribution flight.

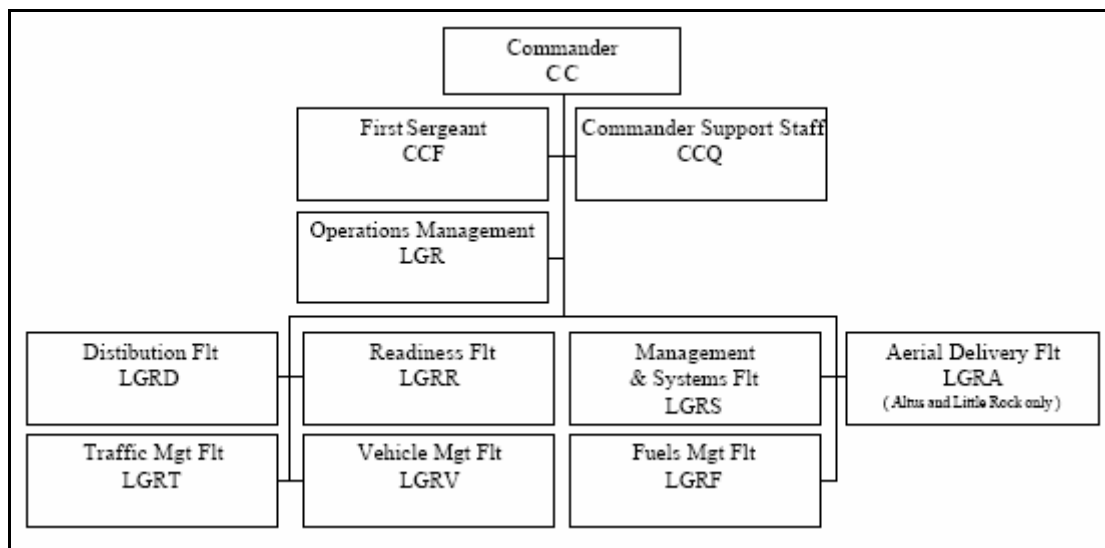

Figure 23. LRS Structure

(PAD 02-05, 2001)

The Materiel Management Section is made up of traditional supply functions. HAZMART, Storage, and Individual Equipment Issue will be located in this section if not outsourced. However, the researcher’s chief concern is with the sections that personally interface with the maintainer—the Flightline Service Center and Aircraft Parts Store. Figure 24, LRS Distribution Flight (LGRD) Structure, provides a visual representation of all sections in LGRD.

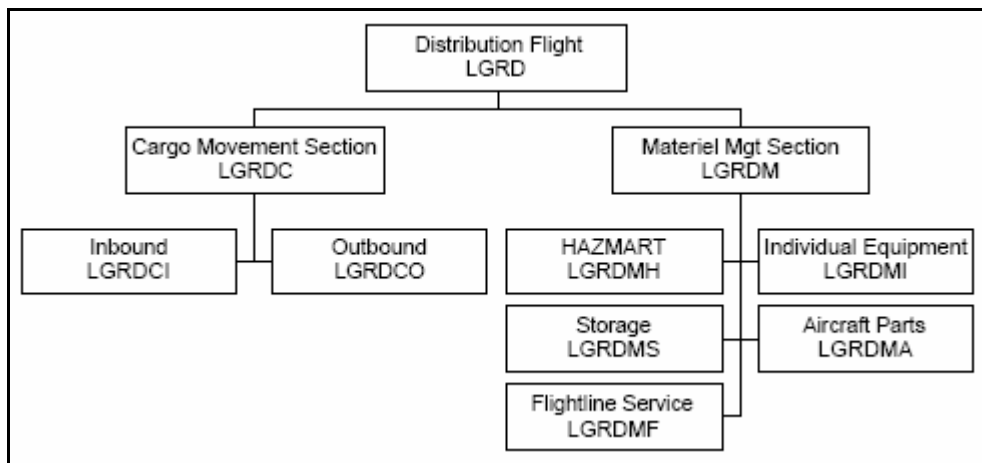

Figure 24. LRS Distribution Flight (LGRD) Structure (PAD 02-05, 2001)

The Aircraft Parts Store (APS) is strategically located next to its primary customer, Aircraft Maintenance. It is largely a warehouse, a storing and staging area for aircraft assets. If a part is available on base, it is usually held in reserve on a shelving unit in the APS.

The key element to this research is the Flightline Service Center (FSC) Element. The FSC is the principal interface with the most important customer, the Aircraft Maintenance and Maintenance Squadrons. The Flightline Service Center acts as the

primary point for submission and preparation of supply items requests, whether received by radio, telephone, intercom, teletype, or mail (AFMAN 23-110, 2005:Volume 2, Part 2, Chapter 2, 2-47). Another key function of the FSC is their repair cycle support. The chief duties of repair cycle support are to manage DIFM items and the AWP list (with the help of their maintenance counterparts), manage Deficiency Reports, and process turn-in transactions (AFMAN 23-110, 2005:Volume 2, Part 2, Chapter 2, 2-52).

They are also responsible for the task formerly completed by the Mission Support element, controlling and requisitioning all MICAP requirements and MICAP reporting, and establishing procedures for coordinating and verifying MICAP data between supply and maintenance activities to ensure that MICAP data are valid (AFMAN 23-110, 2005:Volume 2, Part 2, Chapter 2, 2-50). In days gone by, the MICAP section could do almost anything to get the part to the customer. However, due to recent draw downs in manpower, several functions of Base Supply were moved to the Regional Supply Squadron. This, of course, leads to almost constant contact with their counterparts at the RSS.

Langley Air Force Base

Langley Air Force Base (LAFB) was selected because it is the home of the Air Combat Command Regional Supply Squadron. They provide supply support to all entities in ACC. While at LAFB, the researcher

ACCRSS

The Regional Supply Squadron (RSS) Concept of Operations (CONOPS) is put in plain words in AFMAN 23-110, Volume 2, Part 6, Chapter 1. It states the intent of the CONOPS is to establish Air Force standard RSS that support the Agile Combat Support CONOPS, providing combatant commanders, i.e., war fighting CINCs, and Major Command commanders with operational materiel distribution command and control and regional weapon system support (2005:1-1). It was born as the Air Force Contingency Supply Support Activity (AFCSSA) during Desert Shield/Storm to effectively manage supply support to units deployed overseas. The AFCSSA transmuted into an RSS in each of the following commands: ACC, Air Mobility Command, United States Air Forces in Europe, and Pacific Air Forces; each dedicated 24 hours a day, 7 days a week to their respective Command.

ACS principles of responsiveness, time definite delivery and resupply, CONUS reach back, and leveraging information technology place strong demands on materiel

distribution activities supporting the EAF (AFMAN 23-110, 2005:Volume 2, Part 6, Chapter 1, 1-1). Particular attention was paid to providing the same unblemished support in peacetime, contingency, and wartime, and in transition from one to another. Also, by centralizing supply command and control functions—such as stock control, weapons system spares support, stock fund management, equipment management, and computer operations—the supply career field could realize a reduction of 570 manpower positions for annual savings of \$25M (Alexander, et al, 2002:15).

The RSS is a three-flight organization, led by a Commander (military) and an Operations Deputy (civilian) and supported by a squadron section. The basic structure is shown in Figure 23, RSS Structure (AFMAN 23-110, 2005:Volume 2, Part 6, Chapter 1, 1-2). The researcher’s primary interest is in the Weapon Systems Flight.

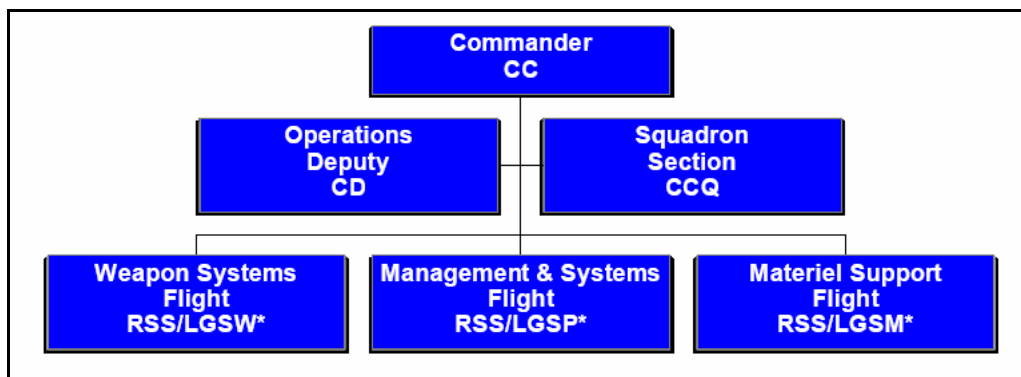

Figure 25. RSS Structure (AFMAN 23-110, 2005)

The Weapon Systems Flight (WSF), which includes MICAP, stock control, and traffic management functions, is primarily responsible for the sustainment of weapon systems, and are organized along weapon systems lines; here flight elements are

organized to support specific weapon systems (e.g., fighter, bomber, tactical airlifter, etc.) or process lines (MICAP, Stock Control, and Traffic Management Elements supporting all weapon systems) (AFMAN 23-110, 2005: Volume 2, Part 6, Chapter 1, 1-2).

To recap, when maintenance personnel place the part on order, they are able to interrogate the entire supply system by using CAMS or SBSS to determine if there are any serviceable assets available in the supply system. This interrogation is checking for assets on Bench Stock, Supply Point, and Mobility Readiness Spares Package (MRSP) details.

Once it's determined that no serviceable assets are available on base and local repair or manufacture capability can not be accomplished, they will submit a memo backorder due-out into CAMS/SBSS and into the MICAP Asset Sourcing System (MASS) with a statement of "MICAP verification complete, RSS please work." MASS is used to identify and provide information on all MICAP requirements. RSS reviews MASS on an hourly basis, if not shorter time frame, and will acknowledge the new MICAP requirement by annotating in MASS, "RSS is working."

The RSS will see this MICAP requisition as a document number. It will look similar to the following: FB206550489002 (FB—Supply; 2065—Identifies the requirement is for SJAFB; 5048—Julian date requirement was established (the 48th day of 2005); 9002—Identifies the requirement is an F-15 MICAP requirement). When the requirement is submitted (i.e. to Depot or another base), FB2065 tells that particular location where to ship that requirement.

No one MICAP is more important than another; however, there is an option to divert a MICAP asset from one location to another. This is done by changing the Supply address (FB2065) to another destination. It is seldom used and is reserved for situations such as when a unit has been forward deployed and is returning to home station. The rule of thumb states when a unit departs the deployed location, all back ordered requirements, including MICAPs, are cancelled and re-established at home station if still required.

WSF personnel interact directly (by telephone, e-mail, etc.) with the base-level supply technicians and upwardly with the Depot-level Item Manager when researching a MICAP. They use a variety of electronic products to accomplish this. The specific product the RSS personnel use to research information on the transaction depends on the Source of Supply for the particular component requisitioned. Common Sources of Supply are Defense Logistics Agency (DLA), Air Force Material Command (AFMC), and all AF bases. RSS will utilize WebCATS when dealing with DLA assets, D035A/K for AFMC, and MASS to source for possible serviceable balances at all of the bases.

WebCATS, or Web Based Customer Accounts Tracking System, is accessed through and maintained by Defense Supply Center Richmond's Home Page. It allows the RSS researcher to make queries by NSN, Requisition Inquiries, Requisition Processing, Weapons System Support, and Special List Processing (WebCATS Desk Guide, 2004:10).

The D035, USAF Stock Control System, is one of several logistics information support systems supporting the AF supply chain. It includes, among many other things, global management of orders, assets, items and inventory levels; web based wholesale

requisition processing; asset visibility; in transit tracking; receipt processing; and inventory accounting (AFI 21-118, 2003:11). It is basically an on-line, interactive wholesale requisitioning process aiding in the timely output of supply status information to Air Force base customers, therefore improving their capability to make timely decisions.

In particular, the RSS uses D035A, Item Manager Requisition Wholesale Processing System, and D035K, Wholesale Receiving and Shipping System. The D035A provides the supply representative with immediate stock control decision-making inputs for customer requisitions, optimal stock distributions, and local asset visibility; the D035K provides functions to include computing retail requirements, property accounting, cataloging and management data, and item visibility (AFMC Guide to Supply Chain Management, 2004:11).

Prioritization is handled differently by each organization. DLA releases requirements based on oldest requisition date, to include priority codes. AFMC uses different programs such as Execution and Prioritization of Repair Support System (EXPRESS, a system used to prioritize repairs at the Depot level to be covered in depth in the next section) in some cases and requisition dates if EXPRESS is not used—again, oldest priority requisitions release first, to include project codes if assigned. For AFMC managed assets, a customer can request a Special Program Requirement (SPR) deviation in an attempt to move ahead of other requisitions, but this is rarely used due to the justification (i.e. Command-level) needed. DLA does not even offer this option.

As is clearly stated in AFMAN 23-110, 2005: Volume 2, Part 6, Chapter 1:

The RSS is the single point of contact for supported units to sources of supply. As such, the RSS provides continuous MICAP support for supported units, to include lateral support sourcing, follow-ups with sources of supply, asset tracking, and status reporting. Supported units will *not* contact item managers, ALC liaisons, or home station directly to obtain status, cannibalization, or other assistance that duplicates RSS responsibilities, jeopardizes inventory accountability, or detracts from handling other supply support requests from the field. As the RSS is a single, recognizable face to supported units, it is also the single, recognizable face to sources of supply. (2005:1-6)

In perfect compliance with the Regional concept, operational base supply sections would allow the RSS to work the MICAP issues within the proper channels. However, most bases still retain a MICAP section to deal with the constant requests and high Wing visibility of MICAP assets. Not only are base-level supply personnel contacting Item Managers, ALC, etc. but base-level maintenance personnel are doing the same.

Everyone is searching for the latest information to present to their superiors at the daily meetings—sometimes at the detriment of others in the room. The Item Manager is the custodian of most of this vital information; however, there are many people involved with the asset at the next level, located at Robins AFB. Key players are the Weapons System Supply Chain Manager, the Program Manager, the Item Manager, and finally the Avionics Repair Facility.

Robins Air Force Base

Robins AFB (RAFB) was selected because it is the home of the Warner Robins Air Logistics Center (WR-ALC). While visiting WR-ALC, the researcher was able to speak with several of the key players in the MPDP at Depot level. In this section, trips to the Weapons System Supply Chain Manager, the Integrated Product Team, and Avionics Repair Facility will be discussed.

Weapons System Supply Chain Manager

As stated previously, Supply Chain Management is a complete cultural change. It involves buy-in from upper management and forces us to look at the entire supply chain instead of solitary items. In the past, the USAF looked only at NSNs; now we are changing from our functional stovepipes or organizational boxes to looking at the whole system that produces, stores, moves, funds, buys, repairs and tracks what the customer wants and needs (AFMC Guide to Supply Chain Management, 2004:2). It also encompasses contracting, maintenance, transportation, and information technology, forcing them to act together in one integrated process to provide the ultimate customer, the warfighter, what they need to defend the nation (AFMC Guide to Supply Chain Management, 2004:2).

Each ALC has a top Supply Chain Manager, usually the Senior O-6, GS-15 or Senior Executive (SES) who leads the organization. They are ultimately responsible for the following (AFMC Guide to Supply Chain Management, 2004:5):

- (1) *Requirements Determination*—determining what is needed in terms of quantity, quality, and time to provide responsive support.
- (2) *Cataloging, Standardization, and Engineering Data Management*—achieving and maintaining a single uniform cataloging system, the highest practicable standardization of items, materials, practices, procedures and terminology, and managing the acquisition, reproduction, retrieval, storage, dissemination and disposal of data.
- (3) *Stock Control and Distribution*—maintaining inventory data on the quantity, location, condition of supplies and equipment due-in, on-hand, due-out to determine quantities of material and equipment available and/or required for issue and to facilitate distribution and management of material. Distribution includes the act of dispensing materiel, services, transportation, storage, and handling activities.
- (4) *Technical Management Functions*—responsibilities involving configuration, maintainability, reliability, and modernization of equipment, service engineering, technical data and product improvement.
- (5) *Pricing*—responsibilities include forecasting sales (revenues), estimating costs such as direct, indirect and general administration, developing operational rates,

evaluating prices for accuracy, and explaining prices and pricing issues to customers.

- (6) *Coordination and Communication*—responsibilities include synchronizing with all elements of the supply chain including those that may not be under the direct control of the Supply Chain Manager to optimize operational and financial support to customers.

Below the ALC Supply Chain Manager is the Weapons System Supply Chain Manager (WS SCM). They are essentially the eyes and ears of their respective weapon system. They provide focus for the weapon system supply chain, are responsible for strategic issues associated with the overall health of the weapon system, and are vitally interested in the impact the lack of spares support will have on their weapon system's established Weapon System Availability (WSA) targets (AFMC Guide to Supply Chain Management, 2004:6). Figure 26, WS SCM Scope, provides an overview of the areas monitored by the WS SCM; keeping in mind, their common focus is to optimize Weapons System Availability and Total Costs of Ownership (AF Portal, eLog 21 Initiatives, 2004).

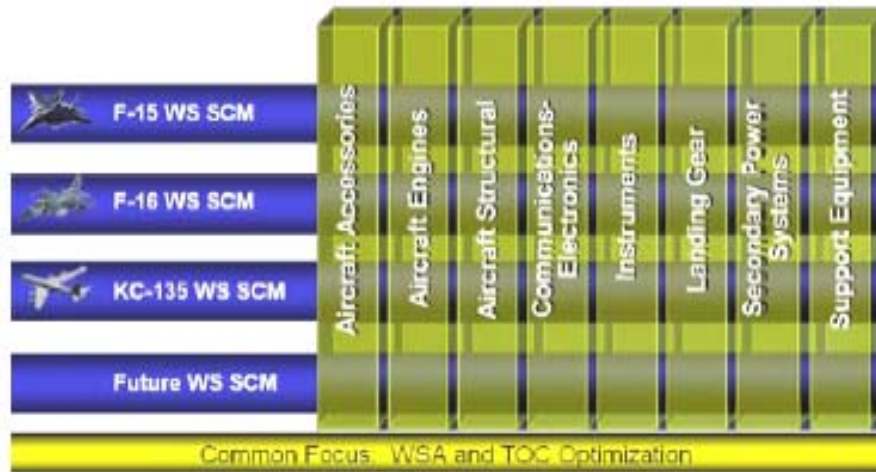

Figure 26. WS SCM Scope (AF Portal, eLog 21 Initiatives, 2004)

The principal responsibilities and characteristics of the WS SCM are as follows (AFMC Guide to Supply Chain Management, 2004:6-7):

- (1) Oversight of all support activity in respect of their weapon system.
- (2) Monitor execution of buy and repair priorities and identify and staff actions necessary to influence execution.
- (3) Maintain visibility of all aspects of supply support to the supported WS utilizing the Common Operating Picture (COP).
- (4) Represent supply chain issues in the Advanced Planning System (APS) determination of optimum demand/workload planning.
- (5) Conduct constraint analysis on situations that impede the achievement of a given WSA target.
- (6) Identify and advocate constraint resolutions.

- (7) Coordinate distribution of intensively managed items with the Lead Command Regional Supply Squadrons (LC RSS).
- (8) Prepare and present a periodic formal review of weapon system support.

Each WS SCM is responsible for multiple system Integrated Product Teams (IPTs). The IPTs consist of the Program Manager, the Item Manager, and in some cases, an Equipment Specialist.

Integrated Product Team

The Program Manager (PM) leads a team of multi-functional professionals in the acquisition and support of Air Force weapons systems. They are responsible for managing and coordinating all aspects of the program to achieve cost, schedule, performance, and sustain goals during the acquisition process. The PM must not only be able to make decisions, but lead and motivate their team to perform effectively. They have an overall view of the whole system and deal with the System Program Office (SPO) at Wright Patterson AFB, Ohio, about new systems yet to be acquired. Each PM has Item Managers working for them (with them) on the IPT.

The Item Manager (IM) is tasked with not only the day-to-day management of an NSN, but also the “cradle-to-grave” aspect, as well. As stated previously, the PM, IM, and ES form the IPT. However, due to the matrix-type structure of the IPTs, the IM may

have numerous PMs, depending on how many systems each are accountable for and how many they have in common.

Specifically the IM for the MPDP is also accountable for the MPCD, the Programmable Signal Data Processor, the VHSIC, and the Wide Field Of View HUD—in all, over 300 NSNs! In this case, the IM is responsible for five specific components (and hundreds of associated NSNs), and has five different PMs. This may lead to a conflict of interests if one PM wants one thing and another PM wants something different.

The IM is in constant contact with the RSS personnel on the “demand” side and the Depot Avionics Repair line on the “supply” side (by telephone, email, electronic products, in person) regarding the status of assets. One item of note is the System Management Analysis Reporting Tool (SMART). Vital information from numerous systems is collected by the IM and manually updated on this web-based product. The fact that it is on the internet means it can be accessed any time—day or night, weekday or holiday. However, the fact that it is manually updated might mean the information is invalid.

Figure 25, SMART Example, provides a look at the information available. Of particular importance to those involved are the availability of assets (in transit, at Depot, and at other bases); repair status of those assets; EXPRESS, MICAP, and D200 data (4/8 quarter moving averages for forecasting spares requirements); and comments by the IM themselves (Cooke, 2005).

ORDER NSN	TOTAL BO	+/- RO	SOS	SDR	Print	Back	<	>	>
-----	013841108					Select Detail Mews...				

PROBLEM ITEM DATA SHEET (PIDS)				02/17/2005	BACKORDERS	2 NEW	D035A
NSN: 1270-01-384-1108FX				Mgr Rev: _			
NOUN: PROCESSOR,RADAR TAR				Budget: 8			
SOS/ORG: WR/LFLV				IMS: UAQ	ES: RR	AAC: C	
IM NAME: David W. Hand / 86108				ERRC: T			

ASSETS (RAMP)	SVC	UNSV	TOTAL	ASSETS at DEPOT				D035A
WWW	INTRAN:	2	3	5				
27	DEPOT:	0	13	13				
VAR	BASE:	5	5	10				
1	TOTAL:	7	21	28				

REPAIR G004L (Current Quarter) / G019C (Past Quarters)				EXPRESS								
SOR: WR	PROD + ADD =	TTL	QTR	Pushed (Attempted Inductions)				32				
Shop: MIF19B	38	0	38	04/3	EXPRESS FIRST FAIL				ITEM #: 1			
Control #: 35539A	30	0	30	04/4	CARC				PARTS	HOURS	FUNDS	SORT VALUE
Work Lvl CSI: 8	24	0	24	05/1	F				9.100014260			
QWD: 4	10	0	10	05/2								
G019C as of: 02/10/2005												

D200 DATA	(SEP 04)	8 Qtr Avg	4 Qtr Avg	RATES %
BASE REP GEN:	96.62	90.75		
NRTS:	17.62	13.25	18%	
RTS:	79	77.5		
MTBD (hours):	175	188		
DEP REP GEN:	5.87	8.75	72%	
DEP O/H REPAIR:	24.75	28.5		
OIM PROGRAM:	169.37	170.5		
DLM PROGRAM:	8.12	8		

BR Cvc	DR L/T	Q&ST	Shp Flo	On Order	DI UnSvc
3 A	22	10 A	21 C	0	0

MDR:	7.0	QDR: 21.00	PSC:	1X00	Rate: 2 Year
------	-----	-------------------	------	------	--------------

Dmd Lvl	RSP Lvl	Prep-Req	RO	+/- RO:	-10
15	4	1	17	%RO:	41.18%

Base D/O	DOTM	D200 Sp Lvl	Curr Rqmt	+/- Dmd
14	0	0	31	29

COMMENTS

~:) david.hand 02/04/2005 (~

Current GWD for Micaps: 28 Feb 05

Problem: Currently 3 assets are on work order in the shop, 6 more are AWP. Production is hampered by shortage of carcasses (3 ea. are out of the normal repair pipeline in MIP status), competing requirements for AWP SRU production, time consuming repair of motherboards and other coas, and distributing shop capacity among several active LRU's(WFDV HUD and MPCDs to name a few). Repair of the 26 layer motherboard is a complicated and time consuming process for the depot. When a MICAP or SURGE requirement hits, the shop is usually able to produce an asset in 5 - 7 days. However when numerous concurrent requirements hit, as is frequently the case, not all of them can be filled as quickly.

Action/Status: WR-ALC/MAI is averaging 1 - 2 MPDP repairs per week. The shop has gone to non-job routing repairs and competes with field requirements for AWP SRU production. Long-term solution is a planned replacement by the Advanced Display Core Processor (ADCP), scheduled to begin installation FY08.

Est. GWD for all backorders - May 06.

Program Manager: Theresa Franzinger, DSN 468-5480
Materiel Manager: David Hand, DSN 468-6108.
[Signed:david.hand]

MICAP DATA			
MDS/TMS	Hours	Rank	Cmnt Hrs
F015	2549	8	2270

APPLICATIONS			
MDS/TMS	PSC	QPA	APPL%
F015E	1X00	1	100

Figure 27. SMART Example (Cooke, 2005)

The IM receives NSN repair information daily automatically through EXPRESS and through meetings such as the Product Availability/Supportability Team (PAST) weekly meeting. The PAST is above and beyond Depot Repair Enhancement Program (DREP) meetings. DREP was initiated to standardize depot repair processes focused on

the daily throughput of parts based on the greatest Air Force need to reduce logistics response time and improve warfighter support (Handy, 1999). Although these are excellent ways of receiving information, they are inherently reactive. EXPRESS will not drive a repair unless a back order has been generated, and any meeting, no matter how good, looks at “what have we done wrong...how can we fix it.”

The last member of the IPT is the Equipment Specialist (ES) is involved in all of the technical aspects of the particular NSN. This includes everything from technical data accuracy to special configurations to working with the SPO regarding the replacement of the asset. The same is true for the ES as was for the IM; they may have multiple PMs, as well.

The IPT tries to resolve each and every encounter, but resolving questions can be time consuming, frustrating, and can take them away from working asset life-cycle issues and providing quality customer support. Item Managers (IPT) need timely and accurate data to allow them to provide realistic delivery dates to customers and to inform repair facilities of changes in priorities; they need to spend less time chasing information and more time managing to meet customer needs (Altarum, et al, 2004:ES-1).

Avionics Repair

The WR-ALC Directorate of Maintenance, Avionics and Instruments Division (MAI), one of the leading USAF Avionics centers, provides depot level test, maintenance, repair, and manufacturing capabilities for our war-fighting forces to include repair, manufacturing, modification, calibration, certification, and engineering support to various airborne electronics weapon systems and associated support equipment (Robins AFB Homepage, 2004). It is an enormous repair line capable of operating around the clock, depending on demand.

The MAI personnel are charged with repairing all avionics associated with WR-ALC Programmed Depot Maintenance—F-15 Eagle, C-5 Galaxy, C-130 Hercules, and C-141 Starlifter. More specifically, they repair over thirty LRUs on their LRU repair line and over 400 SRUs on their SRU repair line. Fortunately, the LRU and SRU lines are collocated in the same building, and a Raytheon Technical Representative is on site for extra assistance, if needed.

As stated in the last section, the Execution and Prioritization of Repair Support System, or EXPRESS, is the heart of the repair cycle. It establishes the precedent in which components will be repaired. EXPRESS takes input from a variety of other sources, including projected and actual customer needs, and determines what the best repair requirement should be; it then prioritizes those requirements, and after repairs are accomplished, distributes the repaired items (Air Force Materiel Command Guide to Supply Chain Management, 2004:12).

EXPRESS is a module of the Weapon System Management Information System (WSMIS), and is one of a series of initiatives implemented as part of the DREP to enhance AF logistics support by focusing on implementing institutional improvements in the depot repair process (Logtech, 2004). It upheld one of the primary expectations of DREP—the use of standard data systems to support specific components of the depot repair process. It replaced the Distribution and Repair in Variable Environments (DRIVE) system, and is built on the DRIVE logic and infrastructure. It is essentially based on an algorithm that is designed to maximize aircraft availability for its customers (Air Force Materiel Command Guide to Supply Chain Management, 2004:12).

EXPRESS updates daily and basically builds a “to-do” list for the MAI management. Each morning, a “workbook” (or EXPRESS printout) is printed out and the day’s schedule of repairs, *to be followed explicitly*, is passed down to the LRU/SRU Line Chiefs. They then apportion the work orders to the appropriate sections.

The inoperative LRUs and SRUs arrive from their various originations and are held in waiting in a large warehouse on one end of the mammoth repair facility. Here, they wait until their number is called by EXPRESS. Of course, if there is little or no demand for the asset, it may sit in the warehouse for a very long time; however, if it is like the MPDP, dust will rarely settle on it before it is on its way to the LRU line.

The components (LRUs and SRUs) are tested on a variety of Electronic System Test Set (ESTS). Multiple components can be run on each ESTS with the insertion of jump-out cables (designed to marry the component with the ESTS), however not

simultaneously. How long a component takes to repair depends on the set up time for the ESTS and the nature of the malfunction.

Avionics repair technicians informed the researcher that the MPDP averages about 45 hours from start to finish. For example, this includes perhaps finding a faulty Circuit Card Assembly (CCA) on the LRU ESTS, ordering the CCA through supply functions, routing the broken CCA to the SRU ESTS, waiting for the repaired CCA (or receiving one immediately if it happens to issue), installing the repaired CCA, and retesting the LRU on the ESTS. When the asset is refurbished, it is return to the supply system and EXPRESS determines the distribution determination.

MAI has a new, exemplary system use to order and track data on parts known as the Lean Depot Management System, or LDMS. LDMS can identify whether or not the needed part is available and, if not, place the part on order. This save many unnecessary steps because the technicians no longer have to research and track down parts; LDMS allows the technician to return to his work station knowing the part will be delivered as soon as it is obtainable (Mathews, 2004:8A). The system also tracks parts usage and, in essence, is designed to have the correct parts available when needed; thereby keeping the repair work on schedule (Mathews, 2004:8A).

A graphic version of the amount of MPDP produced versus the amount demanded is depicted in Figure 27, Depot MPDP Production Vs Backorders. The repair (production) data was provided by HQ AFMC, Depot Operations Division, Process Improvement and Performance Branch, and consists of monthly production data for the MPDP for Fiscal year 2002, 2003 and 2004 (AFMC, 2004). The demand (backorder)

data was also provided by the Process Improvement and Performance Branch, and consists of monthly demand data for the MPDP for the same period (AFMC, 2004). One can clearly see demand clearly outweighs supply, and not enough MPDP are being repaired locally (at intermediate level) to narrow the gap.

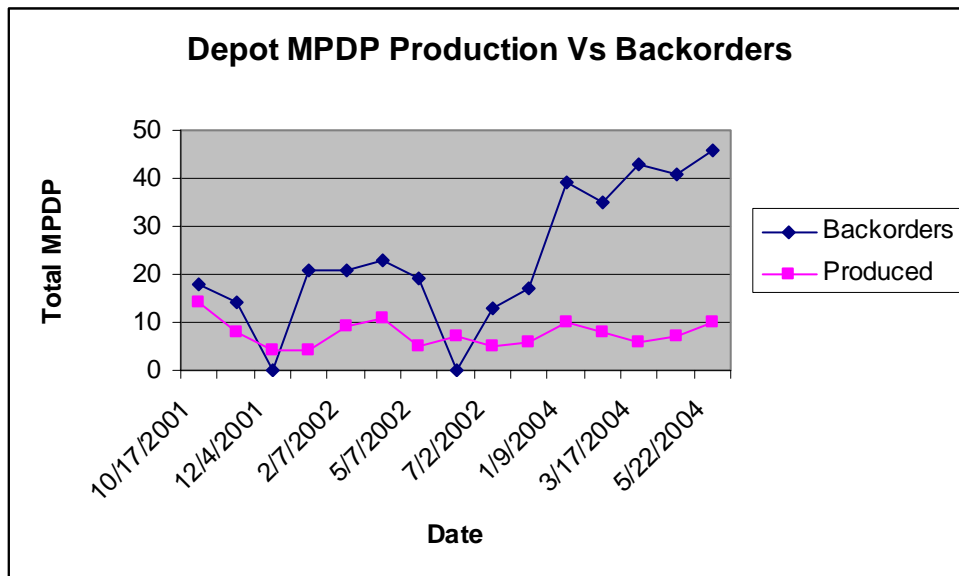

Figure 28. Depot MPDP Production Vs Backorders (AFMC, 2004)

Summary

This chapter presented findings discovered by the researcher during his visit to three key areas of the USAF pipeline/supply chain. The chapter began by addressing the first visit was to Seymour-Johnson Air Force Base, and while there visiting the 4th OSS, the 4th AMXS, the 4th CMS, and the 4th LRS. The next visit was to Langley Air Force Base to visit with Command-level supply personnel. Lastly, he traveled to Robins Air Force Base where he communicated with the Integrated Product Team and others regarding their involvement with the MPDP. The following chapter documents the researcher's conclusions of the case study and recommendations for further research.

VI. Conclusions and Recommendations

Chapter Overview

The previous chapters have given the overall picture for this case study. The researcher provided a background for the research topic of a case study of the degree of collaboration between various levels in the repairable chain in the United States Air Force and stated the overall research question and subsequent investigative questions used during the research. Then he reviewed the terminology and examined current literature concerning recent Supply Chain Initiatives and Collaborative Planning, Forecasting, and Replenishment (CPFR). From there, he described the methodology used to conduct the research. Next the researcher presented a case study narrative the selected NSN—1270-01-384-1108, better known as the F-15E Eagle Multipurpose Display Processor (MPDP). Finally he presented findings discovered during his visit to three key areas of the USAF pipeline/supply chain.

In this chapter, the researcher will attempt to answer the Investigative Questions presented in the first chapter of this work and ultimately endeavor to answer the Research Question itself. Lastly, he will recommend area for further research.

Investigative Questions Revisited

Investigative Question One

What are the material, information, and financial flows of a reparable item in the United States Air Force?

In the cradle-to-grave life cycle of an AF reparable, there are many flows of which to note. The primary three—material, information, and financial—all are worthy of examining. It is important to mention, they require no specific sequence. As a matter of fact, each run throughout the life of the asset.

In the beginning, information flows between the contractors and AF as they decide who, in fact, will receive the bid for the contract. This may involve material and financial flow, as well, if the AF requires prototypes of the equipment, regardless of the size of the project—be it a new AF fighter or a new avionics component. This discourse continues over the life of the asset. Let us concentrate on the reparable item.

The reparable item enters service usually under a warranty. During this phase, all repair work is done by the party awarded the contract. In this phase, hopefully all of the faults are worked out of the reparable. Constant communication is vital as the AF provides the contractor with fundamental information needed to make any modifications needed. Upon expiration of the warranty, repair of the asset is turned over to AF organic

repair facilities. By this time, the Technical Orders should be established as quality documents. However, even in these late stages of the process, maintainers may find mistakes. These can be corrected through the proper channel, sometimes even resulting in the technician receiving a cash reward for their diligence.

During the life cycle, there is an abundance of material, information, and financial flow regarding the reparable. The MPDP has been in service, in some form or another, since 1986. There have been several upgrades in the MPDP which require all of the flows. Also, any time the asset is demanded, material, information, and money are exchanged. The AMXS personnel initially requisition the asset if it cannot be repaired by their avionics counterparts in the CMS. The AMXS Commander must then purchase the component with Transportation Working Capital Funds from the LRS Commander's Stock Fund; that is, if the asset is available on base. If not, various systems (CAMS, SBSS, etc.) are queried for information regarding the component.

If the asset is backordered, it becomes MICAP and other agencies get involved. RSS personnel are in constant contact with the NSN IPT (chiefly the IM), and they go to work to get the appropriate part to the correct location. The IM is responsible for the requirements determination, supply distribution, procurement and provisioning, requirements and distribution analysis, and funds management for items managed (AFMC Guide to Supply Chain Management, 2004:51). He communicates directly with the Avionics Repair lines upwardly and RSS downwardly throughout the entire life cycle.

As the life cycle ends, many of the aforementioned flows continue to be essential. Usually, the end of a life cycle for one asset is the beginning of the life cycle for another.

A perfect case in point is the MPDP; it is at the end of its usefulness. It is operating on early 1980s technology (even with upgrades) with low reliability and severe computer resource limitations; for example, it contains 44 Circuit Card Assemblies. Its replacement, the Advanced Display Core Processor, contains only 12 CCA, and is capable of many more functions. For continuity's sake, the same IM will be responsible for the ADCP after the MPDP has departed.

All in all, material, information, and financial flows keep the AF logistics chain moving. If there is a breakdown in any of the three, it is a critical break in the continuum. However, our old friend communication rears its head yet again. Material does not move itself. Information, although much of it is automated, still requires human guidance and correction. Lastly, financial matters must be settled person to person. Without communication, none of these flows can take place.

Investigative Question Two

What are the partner relationships between Depot Maintenance, RSS, and operational bases?

Merriam-Webster defines partnership as follows: “a legal relation existing between two or more competent persons who have contracted to place some or all of their money, efforts, labor, and skill in lawful commerce or business with the understanding

that there shall be a communion of profit between them” (1976:1648). While no contract has been signed between the three institutions focused upon in this research, they are indeed partners. The “profit” in this case is ultimately getting the aircraft wheels off the ground, on time.

Let us first examine the relationship between the operational base and RSS. The bread and butter of the operational base is the on time departure of aircraft. No matter what metrics you use to look at your individual situation that is what matters in the long run. For instance, if an aircraft misses a sortie, the Wing Commander “notifies” his various Group Commanders, who in turn look to their involved Squadron Commanders until the real answer is known. Unfortunately, what rolls downhill at the base level can do the same thing at the RSS level.

The “communion of profit” is felt when neither has to go through the scenario detailed above. Also, there may well be very important customers on the other end of that sortie who are relying heavily on the fact that it will depart on time. Further down from the operational base and RSS is the interaction of the individual squadrons at the operational base. Partnering is vital at this level as well.

If there is no sense of partnership between base level squadrons, all is lost. When a part is removed from an aircraft by an AMXS troop and given to either a CMS troop to repair or a LRS troop to forward to Depot, it must be treated as a priority. It is easy to get the “that’s not my problem” attitude when you don’t actually feel the pain personally, but you must put yourself into their shoes and know if they (partner!) hurt, then you hurt.

Next is the relationship between the RSS and Depot. This relationship is even harder to define. RSS has limited customers, and in some cases, such as the one covered in the research, individual flights are tasked with individual airframes. This keeps the amount of people involved relatively small. Depot, on the other hand, is a huge unit of people who, for the most part, are greatly separated from the airman on the flightline. Depot personnel go to work every day, read the priority schedule of assets to repair that day, and go to work on that schedule.

It is important to remember MAI repairs all of the avionics for four separate airframes; the one day this researcher visited the avionics repair section, there were more than 200 LRUs and 900 SRUs on the EXPRESS to-be-worked sheet! Therefore, it may be hard for the depot repair technician, through no fault of his own, to feel the pain of the others in the chain. Moreover, if the requirement is not on the daily EXPRESS sheet, the technician has no idea what is going on away from his bench.

The flightline maintainer may feel helpless in the overall situation, but their demand is crucial first step. The intermediate avionics technician may feel small in the big picture, but the quicker he repairs the asset or turns it in as Not Repairable This Station, the shorter the total supply chain will be. The supply technician must treat each of these MICAPs requisitions as the most important; RSS must do the same. Of course, the folks at WR-ALC are vital to the situation. The WS SCM must listen to his IPT and certainly their IM—they have their finger on the pulse of the asset, from the repair at depot to the final destination. Even though at some times the point may seem moot,

communication is the key.

Investigative Question Three

In what areas can Depot Maintenance, RSS, and operational bases realize improvements by adopting CPFR processes?

Before we attempt to answer this question, let us recap the 8 key steps in the CPFR process. They are as follows: Collaboration Arrangement, Joint Business Plan, Sales Forecasting, Order Planning/Forecasting, Order Generation, Order Fulfillment, Exception Management, and Performance Assessment (VICS, 2004), also remembering that we may be involved in any or all of the steps at the same time.

Unfortunately, whether we want to be or not, we are involved in a Collaboration Arrangement. A Collaboration Arrangement is the process of setting the business goals for the relationship, defining the scope of collaboration and assigning roles, responsibilities, checkpoints and escalation procedures (VICS, 2004). Each level in the process has been predetermined many years previously, but overall is the mission.

The Joint Business Plan then identifies the significant events that affect supply and demand in the planning period (VICS, 2004). While there are no such things as promotions and store openings/closings, we do have inventory policy changes and

sometimes product introductions. Much of this is done automatically through various AF legacy systems.

Sales Forecasting (projecting consumer demand at the point of sale), Order Planning/Forecasting (determining future product ordering and delivery requirements based upon the sales forecast, inventory positions, transit lead times, and other factors), and Order Generation (transitions forecasts to firm demand) (VICS, 2004). Again, legacy systems track this input with the help of forecasting tools such as Regression, Time Series Decomposition, Moving Averages, and Autoregressive/Integrated Moving Averages.

Order Fulfillment is the process of producing, shipping, delivering, and stocking products for consumer purchase (VICS, 2004). EXPRESS handles the production, shipping, and delivery, but, as stated previously, it cannot drive production to fill up the warehouse.

Exception Management, the active monitoring of planning and operations for out-of-bounds conditions and Performance Assessment Analysis, the calculation of key metrics to evaluate the achievement of business goals, uncover trends or develop alternative strategies are the last steps (VICS, 2004). Of course, we have metrics of metrics to measure every little step we take. We must ensure, however, our metrics are correct and easily understood.

We currently have numerous systems tracking numerous things. However, a new system, the Advanced Planning and Scheduling (APS) System is being generated to do these even better. It is essentially an ERP with its eyes on the entire supply chain.

According to its designers it will provide integrated modules for the following: demand planning (forecasting, planning, and management), supply planning (procurement, inventory, and distribution), production planning (planning, rough cut capacity planning, and detail scheduling), collaboration (collaborative planning, monitoring, and measurement of enterprise-wide metrics), and transportation (routing and scheduling) (Bearing Point, 2004).

Investigative Question Four

What barriers currently exist to implementing CPFR?

In the past, the AF has not been overwhelmingly effective at implementing new processes. Careful consideration must be taken as to what exactly is wrong and how exactly can this new process help us. Again, any or all of the steps of CPFR may improve our current processes. CPFR is a business practice that combines the intelligence of multiple trading partners in the planning and fulfillment of customer demand (VICS, 2004). We have superior knowledge of the supply chain in our resident subject matter experts, and if we use this human “intelligence”, we can create a great system. We must get over the fear of change and implement wisely.

CPFR links sales and marketing best practices, such as category management, to supply chain planning and execution processes to increase availability while reducing

inventory, transportation and logistics costs (VICS, 2004). This statement, while not custom-fit to our situation, should embody our overall objective. Our only exception would be the “sales” aspect. By using commercial best practices, we can more accurately monitor and forecast our demand. It appears APS will bring some of this to the fight and thereby reduce our total costs.

Communication is also a key barrier. We must remember CPFR is an ongoing process that we may be involved in any or all of the steps at the same time. Any time this is the case, value added communication is vital. Great amounts of our “communication” are automatically done through systems talking to each other. We must ensure these systems are transmitting data that is essential and of the right variety. If this involves a complete scrub of current legacy systems, so be it; it would be money well spent. This, of course, can only be done through the communication of humans! As noted earlier, we have a plethora of brilliant subject matter experts; we must not forget them when implementing any process.

Research Question Revisited

What opportunities exist between Depot Maintenance, Regional Supply Squadron (RSS), and Operational Bases for implementation of the CPFR processes?

Again, let us review the ultimate CPFR Model to attempt to answer our research question. It is represented in Figure 28, VICS CPFR Manufacturer and Retailer Tasks Model (VICS, 2004).

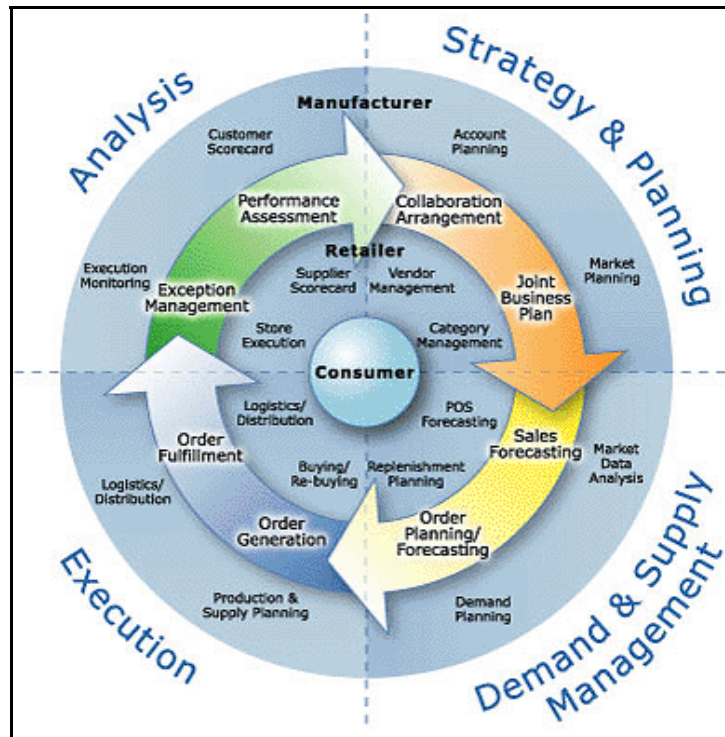

Figure 29. VICS CPFR Manufacturer and Retailer Tasks Model (VICS, 2004)

As we can see the model is broken into four major areas: Strategy and Planning, Demand and Supply Management, Execution, and Analysis. It is this researcher's view that Depot Maintenance falls into the Manufacturer role, RSS (and some base level supply functions) falls into the Retailer role, and the Operational Bases are the eventual consumer. This is especially true if we view the final product as a Fully Mission Capable aircraft departing on time.

The vast majority of the CPFR steps are automated in the current AF logistics arena. However, of course, there is always room for improvement. In the first quadrant, Strategy and Planning, we see the collaboration agreement and joint business plan. These have long since been established, but it is imperative for one to know the others goals and mission. They are forced into long term partnerships, but must work together to achieve these goals. Only through open communication and information sharing can they truly experience the true rewards of collaboration.

In the next section, Demand and Supply Management, there is sales forecasting and order planning/forecasting. As stated previously, these are highly automated. However, we must remember the old adage “garbage in, garbage out.” We must ensure our people are diligent when processing any type of transaction; wrong information could skew the forecast months down the line. Even the best forecast must be monitored, and when collaborating, two sets of eyes are infinitely better than one.

Execution brings order generation and fulfillment. There are processes in place for placing orders, preparing and delivering shipments, receiving the product, and making payment for the product—again, mostly automated. Nevertheless, we must strive to look for improvements, remembering that CPFR is an end-to-end process, meaning what we change may mean little to us but mean a great deal to a partner.

If there is one thing the AF does, that is analyze! We have metrics on top of metrics. Therefore, we must do our utmost to ensure these metrics calculate key performance, share insights, and allow for adjusting of processes for continuous improvement.

It appears the AF got it right in their acquisition of the ADCP. PNUM 33, the Executive Summary of the F-15E Multipurpose Display Processor (MPDP) Upgrade, is a story of collaboration from beginning to end. It tells of the acquisition of the ADCP and how it came to be. The F-15E community spoke explicitly with their contractor in an open forum about their wants and needs, specifically the application of commercial hardware and software technology (PNUM 33, 2004). Above that, the Navy F-18 Hornet is scheduled to be retrofitted to use the ADCP, as well.

The Defense Advanced Research Projects Agency (DARPA), the central research and development organization for the Department of Defense (DOD), played a key role in the process. They initiated the Commercial Operational and Support Savings Initiative (COSSI), allowing the AF and the Navy to collaborate openly with their contractor, Boeing. The AF even showed their support by signing a Cooperative Research and Development Agreement (CRADA) on 13 April 1997 to provide the Boeing Company with an F-15E (PNUM 33, 2004). The AF and Navy representatives continue to be involved daily with the MPDP replacement.

Just a few of the results of the collaboration are the following (PNUM 33):

1. Creation of an Integrated Product Team—Members of F-15 Project Team participated across multiple Boeing open system/acquisition reform activities. Lessons learned and data shared across these programs. Project Team also met with multiple key avionic suppliers to obtain supplier perspectives and to jointly produce specifications and validation/verification procedures for the ADCP.

2. Performance Specifications and Improved Environmental Descriptions—F-15 environmental analysis on aircraft cold/hot operations has provided better definition of the current F-15E environment. Detailed data is being documented and will be made available to the supplier community to better determine the viability of commercially based products.
3. Software/Hardware Metrics and Built-In Test (BIT) Philosophy—Detailed BIT philosophy, applicable to all aircraft programs, established in close coordination with suppliers and USAF logistics personnel.

Also, all of the experiences of the collaboration have been documented to provide a model for future programs (PNUM 33, 2004).

Recommendations for Future Research

This research provided an overall look at the flows and relationships to identify opportunities Air Combat Command Regional Supply Squadron (ACCRSS), Depot Repair Facilities, and Operational Bases. It was a sweeping, all encompassing look at the entire AF supply chain. Perhaps the chain can be broken into smaller sections and viewed more in depth. There are opportunities for improvement in the smallest of areas to include flow between squadrons, flow between sections at RSS, and even flow between members of the IPT.

Another area of interest is our existing legacy systems. Is APS the cure-all it is being advertised as? Does EXPRESS do the best job of prioritizing repair and distribution? Are there other systems (either legacy or commercial) which could possibly do the job better?

Summary

This chapter symbolized the conclusion of all of the researchers work. In this chapter, the researcher answered the Investigative Questions and Research Question presented in the first chapter of this work by recapping various CPFR processes and made several proposals for solutions to problems encountered. He then made recommendations for further research.

Bibliography

“Air Force Materiel Command Guide to Supply Chain Management.” HQ AFMC/LGI, Version 8.3, July 2004.

Air Force Portal. “Weapons System Supply Chain Management Fact Sheet.”
<https://www.my.af.mil/gcss-af/USAF/AFP40/Attachment/20041006/WS%20SCM%20Fact%20Sheet.pdf>.
Accessed 15 December 2004.

Alexander, Debbie, John Gunselman, Jody Cox, Jonathan Matthews, Gregory Grehawick, Christopher Brockaway, Jondavid DuVall, Joseph Codispoti, and Charles Masters. “2002 Spares Campaign: Supply Chain Command and Control.” *Air Force Journal of Logistics*. Volume XXVI, number 3, 2002, pp.10-17.

Altarum, ICF Consulting, Headquarters Air Force Materiel Command, Rockwell Collins, and WR-ALC. “The Final Report for the Development and Deployment of Contract Repair Information System Protocol (CRISP) Technologies.”
http://dsc.atcorp.org/documents/CRISP_PHASE3_FINALREPORTchedits.doc.
Accessed 15 December 2004.

Balaban, Harold S., Robert T. Brigantic, Samuel A. Wright, and Anthony F. Papatyi. “A Simulation Approach to Estimating Aircraft Mission Capable Rates for the United States Air Force.” *Proceedings of the 2000 Winter Simulation Conference* J. A. Joines, R. R. Barton, K. Kang, and P. A. Fishwick, eds. 2000, pp. 1035-1042.

Baughner, Joseph. “Joe Baughner’s Encyclopedia of American Military Aircraft.”
http://www.csd.uwo.ca/~pettypi/elevon/baughner_us/. Accessed 15 December 2004.

Bearing Point. Class slide, Enhanced Supply Chain Integration Through APS. Module 7: SCM Operational And Process Analysis Tools and Information Technology Initiatives. Supply Chain Management Course, Air Force Materiel Command, Wright-Patterson AFB Ohio, 2004.

Billington, P.J., J.O. McClain, and L.J. Thomas. “Mathematical Program Approaches to Capacity-Constrained MRP Systems: Review, Formulation, and Problem Reduction.” *Management Science*. Volume 29, number 10, 1983, pp.11-26.

Bowersox, D. L. *Logistical Management: A Systems Integration of Physical Distribution, Materials Management and Logistical Coordination*. New York New York. Macmillan, 1974.

- Burt, David N., Donald W. Dobler, and Stephen L. Starling. *World Class Supply Management: The Key to Supply Chain Management*. Boston Massachusetts. McGraw-Hill, 2003.
- Chapman, Suzann. "Air Force Implements New Wing Structure." *Air Force Magazine*. Volume 84, number 6, 2002, pp. 16-17.
- Cooke, Marshaye, O. F/A-22 Command Weapons System Manager. ACCRSS, Langley Air Force Base. Personal Interview. 18 February 2005.
- Council of Supply Chain Management Professionals Web Page. "CSCMP Definition of Supply Chain Management."
<http://www.cscmp.org/Website/AboutCSCMP/Definitions/Definitions.asp>. Accessed 15 December 2004.
- Creswell, John W. *Research Design: Qualitative, Quantitative, and Mixed Methods Approaches*. Thousand Oaks California. Sage Publications, 2003.
- Crum, Colleen, and George E. Palmatier. *Demand Management Best Practices: Processes, Principles and Collaboration*. Boca Raton Florida. J. Ross Publications, 2003.
- Defense Supply Center Richmond. "WebCATS Desk Guide."
<http://www.dscr.dla.mil/UserWeb/procurement/CATS/cr.htm>. Accessed 15 December 2004.
- Dennis, Pascal. *Lean Production Simplified: A Plain-Language Guide to the World's Most Powerful Production System*. New York New York. Productivity Press, 2002.
- Department of the Air Force. *F-15E Flight Manual*. Air Force Technical Order 1-F-15E-1. Washington: HQ USAF, 15 July 2004.
- Department of the Air Force. *Flying Operations: Flying Hours Program*. Air Force Policy Directive 11-1. Washington: HQ USAF, 10 August 2004.
- Department of the Air Force. *Flying Operations: Flying Hours Program Management*. Air Force Instruction 11-102. Washington: HQ USAF, 5 April 2002.
- Department of the Air Force. *Improving Air and Space Equipment Reliability and Maintainability*. Air Force Instruction 21-118. Washington: HQ USAF, 2 October 2003.

- Department of the Air Force. *Indicating/Recording Systems: USAF Series F-15E Aircraft*. Air Force Technical Order 1-F-15E-2-31GS-00-1. Washington: HQ USAF, 15 November 2004.
- Department of the Air Force. *Program Action Directive (PAD) 02-05: Implementation of the Chief of Staff of the Air Force Direction to Establish a New Combat Wing Organization Structure*. Washington. Headquarters United States Air Force, 2002.
- Department of the Air Force. *Requirements for Secondary Items (D220A, D220N)*. Air Force Manual 23-1. Washington: HQ USAF, 13 September 2004.
- Department of the Air Force. *Two Level Maintenance and Regional Repair of Air Force Weapons Systems and Equipment*. Air Force Instruction 21-129. Washington: HQ USAF, 1 May 1998.
- Department of the Air Force. *USAF Supply Manual*. Air Force Manual 23-110. Washington: HQ USAF, 1 January 2005.
- Dorr, Robert F. and David Donald. *Fighters of the United States Air Force: From WWI Dogfighters to the Stealth Fighter*. New York New York. Military Press, 1990.
- Eisenhardt, Kathleen M. "Building Theories from Case Study Research." *Academy of Management Review*. Volume 14, Number 4, 1989, pp.532-550.
- F-15 Instrument Panels: Jet Fighters, McDonnell Douglas F-15 Eagle. <http://gra.midco.net/mlgould/Jet%20Fighters/Jet%20Fighters.html#F15>. Accessed 15 December 2004.
- F-15 Systems Program Office Website. <https://f15spo.robins.af.mil/index.cfm>. Accessed 15 December 2004.
- Frankfort-Nachmias and David Nachmias. *Research Methods in the Social Sciences*. New York New York. St. Martin's Press, 1996.
- Gething, Michael L. *Volume 1: Modern Fighting Aircraft: F-15*. New York New York. Arco Publishing, Inc., 1983.
- Goldratt, Eliyahu M. *The Goal*. Croton-on-Hudson New York. North River Press, 1992.
- Goldratt, Eliyahu M. *What Is This Thing Called Theory of Constraints and How Should It Be Implemented?* New York New York. North River Press, Inc., 1990.

- Green, William and Gordon Swanborough. *The Complete Book of Fighters: An Illustrated Encyclopedia of Every Fighter Aircraft Built and Flown*. New York New York. Smithmark Publishers, 1994. p.371.
- Handy, John W. “Statement of Lieutenant General John W. Handy, Deputy Chief of Staff, Installation and Logistics, United States Air Force.”
<http://www.house.gov/hasc/testimony/106thcongress/99-02-25handy.htm>. Accessed 15 December 2004.
- Harmon, R. L. *Reinventing the Warehouse: World Class Distribution Logistics*. New York New York. Free Press, 1993.
- Hines, Peter, Richard Lamming, Daniel Jones, Paul Cousins, and Nick Rich. *Value Stream Management: Strategy and Excellence in the Supply Chain*. Harlow England. Financial Times Prentice Hall, 2000.
- Hugos, Michael. *Essentials of Supply Chain Management*. Hoboken New Jersey. John Wiley & Sons, 2003.
- Jablonski, Joseph. *Implementing TQM: Competing in the Nineties Through Total Quality Management*. San Diego California: Pfeiffer & Company, 1992.
- Kolacia, Mike, Jennifer Kranzel, Dirk Mieth, and Fuyuki Saka. “CPFR Implementation.”
<http://www.som.syr.edu/som2/mkkolaci/scm402/implementation.html>. Accessed 15 December 2004.
- Langenwalter, Gary A. *Enterprise Resource Planning and Beyond: Integrating Your Entire Organization*. Boca Raton Florida. St. Lucie Press, 2000.
- Leedy, Paul D. and Jeanne E. Ormrod. *Practical Research: Planning and Design*. Upper Saddle River New Jersey. Merrill Prentice Hall, 2001.
- Logtech, Inc. “*Management Philosophy underlying the Execution and Prioritization of Repair Support System (EXPRESS): EXPRESS Information Handbook*.” Technical Support and Analysis for the Air Force Materiel Command Logistics Directorate Item Management Division Logistics Programs Branch. 13 February 2004.
- Lopez, C. Todd. “New Logistics Squadron Serves as Focal Point for Distribution.”
http://www.af.mil/news/story_print.asp?storyID=92602423. Accessed 15 December 2004.

- Luscombe, Martyn. *MRP II: Integrating the Business, A Practical Guide for Managers*. Oxford England. Butterworth-Heinemann Ltd, 1993.
- Mathews, Lisa. "New System Tracks Parts Data for MA Workers." *Robins Rev Up*. Volume 49, Number 42, 22 October 2004, p. 8A.
- Matthews, William. "Midlife Crisis--Aging Planes Are a Maintenance Challenge." *Air Force Times*. Issue 58, 20 April 1998, pp. 12-15.
- Mentzer, John T., William DeWitt, James S. Keebler, Soonhong Min, Nancy W. Nix, Carlos D. Smith, and Zach G. Zacharia. "Defining Supply Chain Management." *Journal of Business Logistics*. Volume 22, number 2, 2001, pp.1-25. ABI/Inform Research.
- Merriam, G. & C. *Webster's Third New International Dictionary Of The English Language Unabridged*. Springfield Massachusetts. G. & C. Merriam Company, 1976.
- Moore, James F. *The Death of Competition: Leadership and Strategy in the Age of Business Ecosystems*. New York New York. Harper Collins Publications, 1996.
- Narasimhan, Ram and Soo Wook Kim. "Information System Utilization Strategy for Supply Chain Integration." *Journal of Business Logistics*. Volume 22, number 2, 2001, pp.51-75. ABI/Inform Research.
- National Museum of the United States Air Force. "McDonnell Douglas F-15A Eagle." http://www.wpafb.af.mil/museum/modern_flight/mf21b.htm. Accessed 15 December 2004.
- Novack, Robert A., Lloyd M. Rinehart, and Michael V. Wells. "Rethinking Concept Foundations in Logistics Management." *Journal of Business Logistics*. Volume 13, number 2, 1992, pp.233-267. ABI/Inform Research.
- O'Leary, D. E. *Enterprise Resource Planning Systems: Systems, Life-Cycle, Electronic Commerce, and Risk*. Cambridge Massachusetts. Cambridge University Press, 2000.
- O'Malley, T.J. *Lean Logistics and Its Impact on the USAF Spares Requirement*. Report Number LMI-AF603RD1. McLean VA: Logistics Management Institute, 1996.
- Olson, David L. *Managerial Issues of Enterprise Resource Planning Systems*. New York New York. McGraw-Hill Companies, 2004.

- Ohno, Taichi. *Toyota Production System: Beyond Large Scale Production*. New York New York. Productivity Press, 1988.
- Oliver, Steven A., Alan W. Johnson, Edward D. White III, and Marvin A. Arostegui. "Forecasting Readiness, Regression Analysis Techniques: Military Operational Readiness." *Air Force Journal of Logistics*. Volume 25, number 3, 2001, pp. 29-40.
- Orlicky, Joseph. *Material Requirements Planning*. New York New York. McGraw-Hill Book Company, 1975.
- Panarisi, Michael T. *A Comparative Analysis of Internal and External Solutions to Provide Air Combat Maneuvering Instrumentation Functionality*. Masters Thesis, The School of Advanced Airpower Studies, Air University, Maxwell AFB AL, December, 2001.
- Peltz, Eric, Hyman L. Shulman, Robert S. Tripp, Timothy L. Ramey, John G. Drew. *Supporting Expeditionary Aerospace Forces: An Analysis of F-15 Avionics Options*. Santa Monica California. RAND, 2000.
- Pinkerton, Richard L. "The Evolution of Purchasing to Supply Chain Management." *Contract Management*. Volume 40, number 2, February 2000, pp.19-26. The Magazine of the National Contract Management Association, Vienna Virginia.
- Ploos van Amstel, M.J. "Managing the Pipeline Effectively." *Journal of Business Logistics*. Volume 11, number 2, 1996, pp.1-26. ABI/Inform Research.
- PNUM 33. "Executive Summary: F-15E Multipurpose Display Processor (MPDP) Upgrade." <http://www.acq.osd.mil/osjtf/msword/33.doc>. Accessed 15 December 2004.
- Ptak, Carol A. *ERP: Tools, Techniques, and Applications for Integrating the Supply Chain*. Boca Raton Florida. St. Lucie Press, 2004.
- Raytheon. "AN/APG Radar." <http://www.raytheon.com/products/apg70/>. Accessed 15 December 2004.
- Robins Air Force Base Home Page. "Warner Robins-Air Logistics Center Product Lines." <https://wwwmil.robins.af.mil/organizations.asp>. Accessed 15 December 2004.

- Scott, Bill. *Manufacturing Planning Systems*. Berkshire England. McGraw-Hill International Limited, 1994.
- Seifert, Dirk. *Collaborative Planning, Forecasting, and Replenishment: How to Create a Supply Chain Advantage*. New York New York. American Management Association, 2003.
- Seymour-Johnson Air Force Base Home Page. "4th Aircraft Maintenance Squadron." <http://www.seymourjohnson.af.mil/4fwunits/mxg/amxs/4amxs.htm>. Accessed 15 December 2004.
- Simchi-Levi, David, Philip Kaminsky, and Edith Simchi-Levi. *Designing and Managing the Supply Chain: Concepts, Strategies, and Case Studies*. Boston Massachusetts. McGraw-Hill Higher Education, 2000.
- Smith, Bernard T. *Focus Forecasting and DRP: Logistics Tools of the Twenty-first Century*. New York New York. Vantage Press, 1991.
- Spencer, M. S. and J. F. Cox III. "Optimum Production Technology (OPT) and the Theory of Constraints (TOC): Analysis and Genealogy." *International Journal of Production Research*. Volume 34, pp. 1495-1504. 1995.
- Stockwell, Mickey L. F-15E Avionics Intermediate Shop Superintendent. Seymour-Johnson Air Force Base. Personal Interview. 27 September 2004.
- Voluntary Interindustry Commerce Standards (VICS). "CPFR: An Overview", 2004. <http://www.vics.org/committees/cpfr/>. Accessed 15 Dec 2004.
- Voluntary Interindustry Commerce Standards (VICS). CPFR Version 2.0, 2002. <http://www.vics.org/committees/cpfr/>. Accessed 15 December 2004.
- Wight, Oliver. *Manufacturer Resource Planning: MRPII: Unlocking America's Productivity Potential*. Essex Junction Vermont. Oliver Wight Publications, 1984.
- Womack, James P. and Daniel T. Jones. *Lean Thinking: Banish Waste and Create Wealth in your Corporation*. New York New York. Simon and Schuster, 1996.
- Womack, James P., Daniel T. Jones, and Daniel Roos. *The Machine that Changed the World: The Story of Lean Production*. New York New York. Harper Perennial, 2001.

Yin, Robert. *Case Study Research: Design and Methods*. Thousand Oaks California. Sage Publications, 2003.

Zettler, Michael E. "Changing Air Force Logistics: Chiefs Logistics Review." *Air Force Journal of Logistics*. Volume 25, number 2, 2001, pp. 2-13.

Vita

First Lieutenant Robert Allen Lee, Jr. graduated from West Henderson High School in Hendersonville, North Carolina. He enlisted in the United States Air Force in 1988 and attended Avionics Guidance and Control Systems Technical School at Kessler Air Force Base, Mississippi. His first active duty assignment was at Sembach Air Station, Germany where he worked the A-10 Thunderbolt II aircraft. From there, he moved to Dover Air Force Base, Delaware where he worked C-5 Galaxy, C-141 Starlifter, and C-17 Globemaster III. Along the way, he had many Temporary Duty assignments to include Italy, Spain, Africa, Germany, Iceland, Puerto Rico, Honduras, Panama, and numerous others. He entered undergraduate studies at Southern Illinois University Carbondale at Dover Air Force Base where he graduated with a Bachelor of Science degree in Industrial Technology in December 2000. He was commissioned through the Officer Training School at Maxwell Air Force Base, Alabama where he was nominated for a Regular Commission.

His first assignment as a commissioned Logistics Readiness Officer was at Travis Air Force Base, California where he was assigned to the 60th Logistics Readiness Squadron. He served there as Management and Systems Flight Commander. In August 2003, he entered the Graduate School of Engineering and Management, Air Force Institute of Technology. Upon graduation, he will be assigned to the Air Combat Command Regional Supply Squadron, Langley Air Force Base, Virginia.

REPORT DOCUMENTATION PAGE				<i>Form Approved</i> <i>OMB No. 074-0188</i>	
The public reporting burden for this collection of information is estimated to average 1 hour per response, including the time for reviewing instructions, searching existing data sources, gathering and maintaining the data needed, and completing and reviewing the collection of information. Send comments regarding this burden estimate or any other aspect of the collection of information, including suggestions for reducing this burden to Department of Defense, Washington Headquarters Services, Directorate for Information Operations and Reports (0704-0188), 1215 Jefferson Davis Highway, Suite 1204, Arlington, VA 22202-4302. Respondents should be aware that notwithstanding any other provision of law, no person shall be subject to a penalty for failing to comply with a collection of information if it does not display a currently valid OMB control number. PLEASE DO NOT RETURN YOUR FORM TO THE ABOVE ADDRESS.					
1. REPORT DATE (DD-MM-YYYY) 21-03-2005		2. REPORT TYPE Master's Thesis		3. DATES COVERED (From - To) September 2003 - March 2005	
4. TITLE AND SUBTITLE A CASE STUDY OF THE DEGREE OF COLLABORATION BETWEEN VARIOUS LEVELS IN THE REPARABLE CHAIN IN THE UNITED STATES AIR FORCE				5a. CONTRACT NUMBER	
				5b. GRANT NUMBER	
				5c. PROGRAM ELEMENT NUMBER	
6. AUTHOR(S) Lee, Robert A., Jr., 1Lt, USAF				5d. PROJECT NUMBER	
				5e. TASK NUMBER	
				5f. WORK UNIT NUMBER	
7. PERFORMING ORGANIZATION NAMES(S) AND ADDRESS(S) Air Force Institute of Technology Graduate School of Engineering and Management (AFIT/EN) 2950 Hobson Way, Building 640 WPAFB OH 45433-8865				8. PERFORMING ORGANIZATION REPORT NUMBER AFIT/GLM/ENS/05-13	
9. SPONSORING/MONITORING AGENCY NAME(S) AND ADDRESS(ES) HQ AF/ILID Attn: Lt Col Glen Marumoto 1030 Air Force Pentagon DSN: 695-6661 Washington, DC 20330-1030 e-mail: Glen.Marumoto@pentagon.af.mil				10. SPONSOR/MONITOR'S ACRONYM(S)	
				11. SPONSOR/MONITOR'S REPORT NUMBER(S)	
12. DISTRIBUTION/AVAILABILITY STATEMENT APPROVED FOR PUBLIC RELEASE; DISTRIBUTION UNLIMITED.					
13. SUPPLEMENTARY NOTES					
14. ABSTRACT Collaborative Planning, Forecasting, and Replenishment and other logistics processes were developed in the commercial sector to reduce total system costs of production while simultaneously providing reduction in inventory levels, improved customer service levels, greater flexibility in scheduling, greater velocity of inventory through the pipeline, and, as a result, greater profitability (Ploos van Amstel, 1990:1). Many companies including Wal*Mart, Motorola, Target, Johnson & Johnson, and Kellogg's, just to name a few, have seen great achievements since implementing CPFR processes. Can these processes be applied to the Air Force supply chain? This thesis intends to examine the flows and relationships to identify opportunities Air Combat Command Regional Supply Squadron (ACCRSS), Depot Repair Facilities, and Operational Bases. This research will use a case study approach to address the research and investigative questions. Air Force supply chain management has many responsibilities that must be accomplished. This thesis will seek to look at many of the variables but does not promise to cover all aspects or attempt to provide the ultimate solution. It will merely present the literature reviewed and the data collected and try to draw a conclusion as to whether civilian CPFR techniques can be applied to current Air Force supply chain practices.					
15. SUBJECT TERMS					
16. SECURITY CLASSIFICATION OF:			17. LIMITATION OF ABSTRACT	18. NUMBER OF PAGES	19a. NAME OF RESPONSIBLE PERSON
a. REPORT	b. ABSTRACT	c. THIS PAGE			Brady, Stephan P., Lt Col, USAF (ENS)
U	U	U	UU	142	19b. TELEPHONE NUMBER (Include area code) (937) 255-3636, ext 7801 Stephan.brady@afit.edu

