

ГОДИШНИК на Минно-геоложкия университет "Св. Иван Рилски", Том 54, Св. III, Механизация, електрификация и автоматизация на мините, 2011
ANNUAL of the University of Mining and Geology "St. Ivan Rilski", Vol. 54, Part III, Mechanization, electrification and automation in mines, 2011

ESTIMATION ON THE SWITCHING LOSSES AT IGBT BRIDGES POWER CONVERTER

Goce Stefanov¹, Ljupco Karacinov² Dobri Cundev¹,

¹ University Goce Delcev, Faculty of Electrical Engineering, 22 October bb., Radovis, R. Macedonia, goce.stefanov@ugd.edu.mk, dobri.cundev@ugd.edu.mk

² University Sts. Cyril and Methodius, Faculty of Electrical Engineering, Karpos 2 bb., P. O. Box 574, Skopje, R. Macedonia, L.Karadzinov@ukim.edu.mk

ABSTRACT. In the paper estimation on the switching losses at IGBT bridge converter with the output serial resonant load is given. The converter works on frequency higher than resonant frequency and supports the work of IGBT transistors in the bridge with zero voltage turn on. In the analysis of the converter, PowerSim and SemiSiel simulation programs is used. The results to the switching losses estimated by simulation are compared with the results in a practical realized converter.

Keywords: switching losses, IGBT transistors, full bridge converter.

ОЦЕНКА НА ЗАГУБИ ОД ВКЛЮЧВАНЕ НА IGBT МОСТЕН КОНВЕРТОР

Гоце Стефанов¹, Љупчо Караџинов² Добри Чундев¹

¹ Универзитет Гоце Делчев-Штун, e-mail goce.stefanov@ugd.edu.mk, dobri.cundev@ugd.edu.mk

² Универзитет Св.Кирил и Методиј-Скопје, e-mail L.Karadzinov@ukim.edu.mk

РЕЗЮМЕ. В статијата оценка на превклучване загуби на IGBT мостен преобразувател с изходно сериен резонансен натоварване е дадено. Конверторът работи на честота по-висока от резонансната честота и поддрепя работата на IGBT транзистори в мост с нулево напрежение вклучите. В анализа на преобразувателя, PowerSim и SemiSiel симулационни програми, се използва. Резултатите на превклучване загуби оценява чрез симулация се сравняват с резултатите на практика реализира конвертор.

1. Introduction

Generally, semiconductor switching devices operate in Hard Switch Mode in various types of PWM DC-DC converters and DC-AC inverter topology employed in a power system, [1], [2], [3]. In this mode, a specific current is turned on or off at a specific level of voltage whenever switching occurs, as shown in Fig. 1, [3].

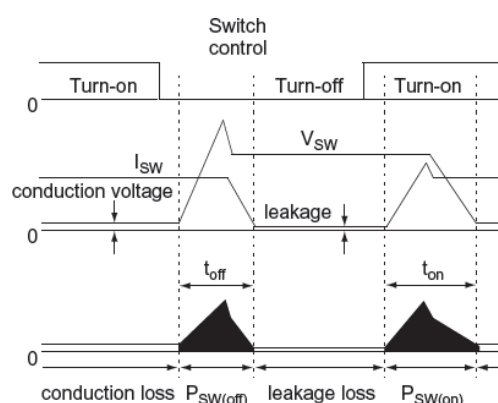

Fig. 1. Wave forms of a semiconductor switching device

This process results in switching loss. The higher the frequency the more the switching loss, which obstructs efforts to raise the frequency. Switching loss can be calculated in a simple way as:

$$P_{sw} = \frac{1}{2} V_{sw} I_{sw} f_s (t_{on} + t_{off}) \quad (1)$$

where,

P_{sw} - switching loss [W]
 V_{sw} - switching voltage [V]
 I_{sw} - switching current [A]
 f_s - switching frequency [Hz]
 t_{on} - switch turn-on time [s]
 t_{off} - switch turn-off time [s]

Switching also causes an EMI problem, because a large amount of di/dt and dv/dt is generated in the process.

By raising the switching frequency, can reduce the size of a transformer and filter, which helps build a smaller and lighter converter with high power density, [3], [4], [5] [6], [7], [8]. But as presented earlier, switching loss undermines the efficiency of the entire power system in converting energy, as more losses are generated at a higher frequency. Switching loss can be partly avoided by connecting a simple snubber circuit parallel to the switching circuit. However, the total amount of switching loss generated in the system remains the same.

The loss avoided, has in fact, just moved to the snubber circuit. Higher energy conversion efficiency at high frequency switching can be obtained by manipulating the voltage or current at the moment of switching to become zero. This is called "Soft Switching", which can be subcategorized into two methods: Zero-voltage switching and Zero-current switching. Zero-voltage switching refers to eliminating the turn-on switching loss by having the voltage of the switching circuit set to zero right before the circuit is turned on. Zero-current switching is to avoid the turn-off switching loss by allowing no current to flow through the circuit right before turning it off. The voltage or current administered to the switching circuit can be made zero by using the resonance created by an L-C resonant circuit. This topology is named a "resonant converter." In Zero-current switching, the existing inductance is absorbed into the resonant circuit, eliminating the surge in voltage in a turn-off situation. A voltage surge resulting from an electric discharge of junction capacitance, which occurs upon turning on the switching circuit, cannot be avoided. This method has a defect of causing switching loss ($0.5CV^2f$). In full bridge serial resonant converter with switching frequency under resonant frequency the output current leads in terms of the output voltage, and this converter support operating of the switches with Zero-current switching (Zero-current turn off). But the transistor in one half bridge turn on in conditions when parallel diode of the other transistor in the same half is turn on. At this moment has stored charge of the diode. And this transistor turn on with a voltage, (non Zero-voltage turn on). Transistor turn-on transition is identical to hard switched, and switching loss occurs.

In full bridge serial resonant converter with switching frequency over resonant frequency the output current lagging in terms of the output voltage, and this converter support operating of the switches with Zero-voltage switching (Zero-voltage turn on). Zero-voltage switching, is free from such a defect by making both the existing inductance and capacitance to be absorbed by the resonant circuit. This eliminates any chance of causing a surge in current both at turn-off (caused by inductance) or turn-on (by capacitance) conditions. Zero-voltage switching enables switching with less loss while substantially reducing the problem of EMI at high frequency. This difference in features make Zero-voltage switching more desirable than Zero-current switching. This is reason for using the series resonant converter at work of the converter on the frequency over resonant frequency. And this topology support work of converter in mode of induction heating.

2. Estimation of the switching losses at power converter

A. Estimation of the switching losses in PowerSim program

To estimation in the switching losses of the semiconductor switches used topology on the full bridge IGBT converter with serial resonant circuit in PowerSim simulation program [9]. On the Fig. 2 a topology of the serial resonant converter is given. This converter work on switching frequency $f_{sw}=6150\text{Hz}$ over resonant frequency $f_0=6000\text{Hz}$, [10]. That is ensure work in the switches in converter in conditions of Zero-voltage turn on, ZVS.

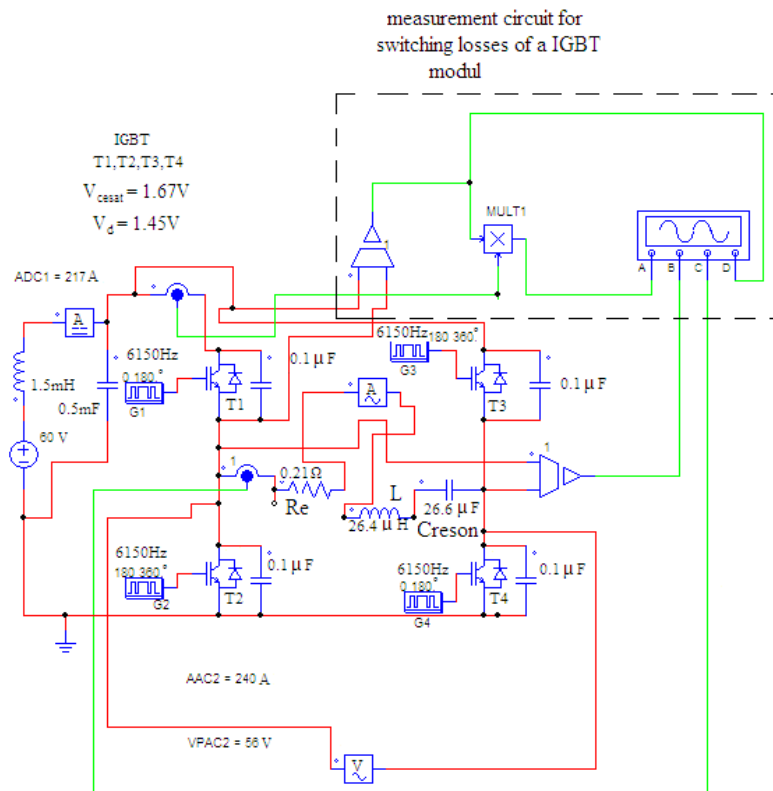

Fig. 2. Simulation circuit of the full bridge serial resonant power converter and circuit to measurement of the switching losses of a IGBT transistor in PowerSim simulation program

The values of the elements in the RCL circuit for resonant frequency is given in the Table 1, [10].

Table 1: Values of the elements in the RCL circuit for resonant frequency 6000Hz.

L (μH)	C_{reson} (μF)	$ Z $ (Ω)	$I_m(Z)$ (Ω)	$R_e(Zind)$ (Ω)	f_o (kHz)
26.4	26.6	1.02	0.98	0.21	6

Also, in the Fig. 2 is given circuit for measurement of the switching losses of a IGBT transistor in the converter.

The work on the converter is simulation with IGBT transistor by $V_{\text{cesat}}=1.67\text{V}$ and diode voltage $V_F=1.45\text{V}$. An IGBT consists of a transistor in anti-parallel with a diode. It is turned on when the gating is high and the switch is positively

biased. It is turned off when the gating is low or the current drops to zero. In PowerSim program is not used system for cooling of the IGBT modules.

In the Fig. 3 is given the wave forms on the output voltage $u_{\text{out}}(t)$ and the output current $i_{\text{out}}(t)$ on the power converter to work over the resonance frequency. Fig. 3 shows that the output voltage lead before the output current to angle $\varphi=3.5^\circ$.

In the Fig. 4 is given the wave forms on the voltage collector – emitter $U_{\text{ce}}(t)$, the collector current $i_c(t)$ and the power losses P_{Tz} on an IGBT transistor in the converter.

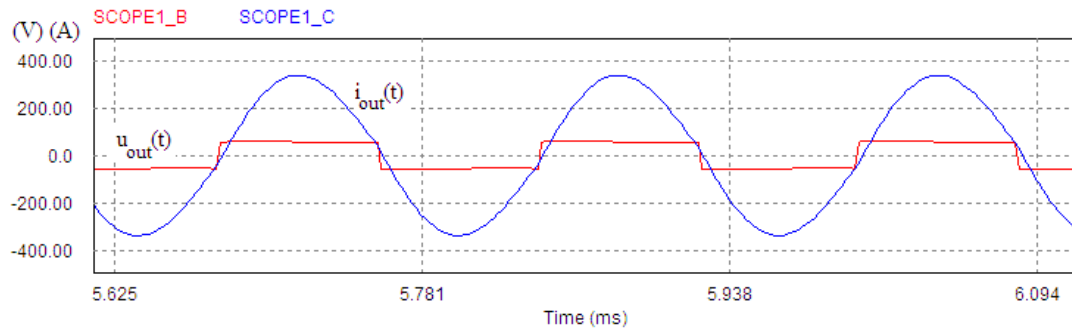

Fig. 3. Wave forms on the output voltage $u_{\text{out}}(t)$ and output current $i_{\text{out}}(t)$ for work of the power converter over resonant frequency

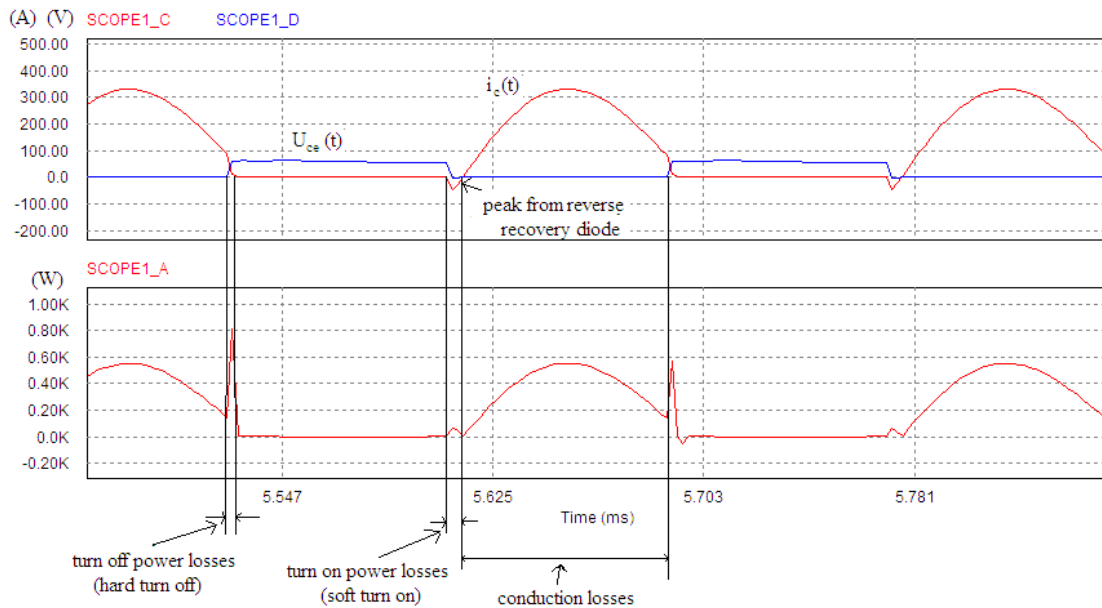

Fig. 4. Wave forms on the voltage collector – emitter $U_{\text{ce}}(t)$, the collector current $i_c(t)$ and the power losses P_{Tz} on an IGBT transistor in the converter

The Fig. 4 shows that the transistor is exposed to stress due the switching mode on work. Turn on power losses are insignificant. Turn off power loss are greater. Turn on is soft (transistor turn on when his parallel diode is turn on, and voltage on it is small). Due to reverse recovery diode (in turn on, the current is transferred from the diode to transistor) peak is occurs.

Transistor turn off hard (current flowing through it in the time of turn off). Also on the Fig. 4 are shows and conduction losses of the transistor.

Based to Fig. 4, in the Table 2 is given the semiconductor stress of who is exposed one of the transistors, power losses and switching power losses in a IGBT transistor.

Table 2: Semiconductor stress, power losses and switching power losses in a IGBT transistor

$U_{\text{CE}}(t)$ (V)		$i_c(t)$ (A)		P_{Tz} (W)		P_{Tsw} (W)	
MAX	average value	max	average value	max	average value	max	average value
62	35	330	104	800	195	750	10

From Table 2 is concludes:

- maximum transistor voltage collector emitter is 62V,
- maximum transistor collector current is 330A,
- the power losses to transistor module P_{Tz} (transistor and diode) are 195W,
- total power losses on four IGBT transistor module in the converter (switching power losses and conduction losses) is $4 \times 195 = 780W$,

- switching power losses of a transistor (transistor and diode) P_{Tsw} is 10W. This power losses obtained from waves forms in the Fig. 4 when the voltage collector emitter into turn on state is 0V.

In the Table 3 is given the value on the magnitudes of the converter, obtained with simulation on the circuit in Fig. 2 in PowerSim program.

Table 3: Value on the parameters of the converter, obtained with simulation in PowerSim program

L (μH)	C_{reson} (μF)	$R_e(Z)$ (Ω)	I_{outms} (A)	U_{outms} (V)	$S_{conv.}$ (kVA)	I_{DC} (A)	U_{DC} (V)	P_{DC} (kW)	P_R (kW)	$\eta_{conv.}$ (%)	P_{cz} (kW)
26.4	26.6	0.21	241	56.4	13.6	217	60	13.02	12.2	93	0.820

In the Table 3 the magnitudes is:

- $U_{outms} = \sqrt{\frac{1}{T} \int_0^T u_{out}^2(t) dt} = U_{DC} - 2V_{cesatIGBT} = 60 - 3.34 = 56.4V$
- $P_R = I_{outms}^2 R_e$ power on resistor load R_e ,
- $P_{DC} = U_{DC} I_{DC}$ power on the DClink circuit,
- $\eta_{conv} = \frac{P_R}{P_{DC}} 100\%$ efficiency on the converter,
- $P_{cz} = P_{DC} - P_R$ total power losses of the converter.

- $P_{cz} / 4 = P_{Tz} = 820 / 4 = 205W$ power losses to transistor module P_{Tz} (transistor and diode)

The values on the switching power losses in Table 2 are obtained by reading in the diagram of the wave form of the losses of Fig. 4. The values of the power losses in Table 3 are obtained by simulation in the circuit in Fig. 2. Can be concluded that the relative error in the difference of the estimation of the losses in both cases is:

$$\xi = \frac{|820 - 780|}{820} 100\% = 4.9\% \quad (2)$$

Dependence of losses of IGBT module with changing to the inductance

In the Table 4 is shows changes on the value of the inductance and the power losses in the converter, obtained with simulations.

Table 4: Change on the power losses to transistor module with changes of the inductance

$\frac{L}{L_{eo}}$	L_{eo} (μH)	P_{Tz0} (W)	$\frac{P_{Tz}}{P_{Tz0}} 100\%$	f_o (Hz)	$\frac{f_o}{f_{eo}} 100\%$
1	26.4	195	100	6150	100
1.1	29	183	94	5863	95
1.2	31.7	173	89	5615	91
1.3	34.3	167	86	5403	88
1.4	37	158	81.5	5197	84.5
1.5	39.6	152	78.6	5027	82

Based on the results of the Table 4 may be the draft diagrams of the dependence of the frequency of changes on the inductance $f = F(L)$ and dependence of the power losses of IGBT module of the frequency $P_{Tz} = F(f)$. On the Fig. 5 a is given dependence on $f = F(L)$.

The Fig. 5 a shows that the change frequency is proportional to $\approx 1/L^{1/2}$.

On the Fig. 5 b is given relative change of the power losses of IGBT module of the change frequency. The Fig. 5 b shows that with increasing on the switching frequency power losses of IGBT module increases linearly.

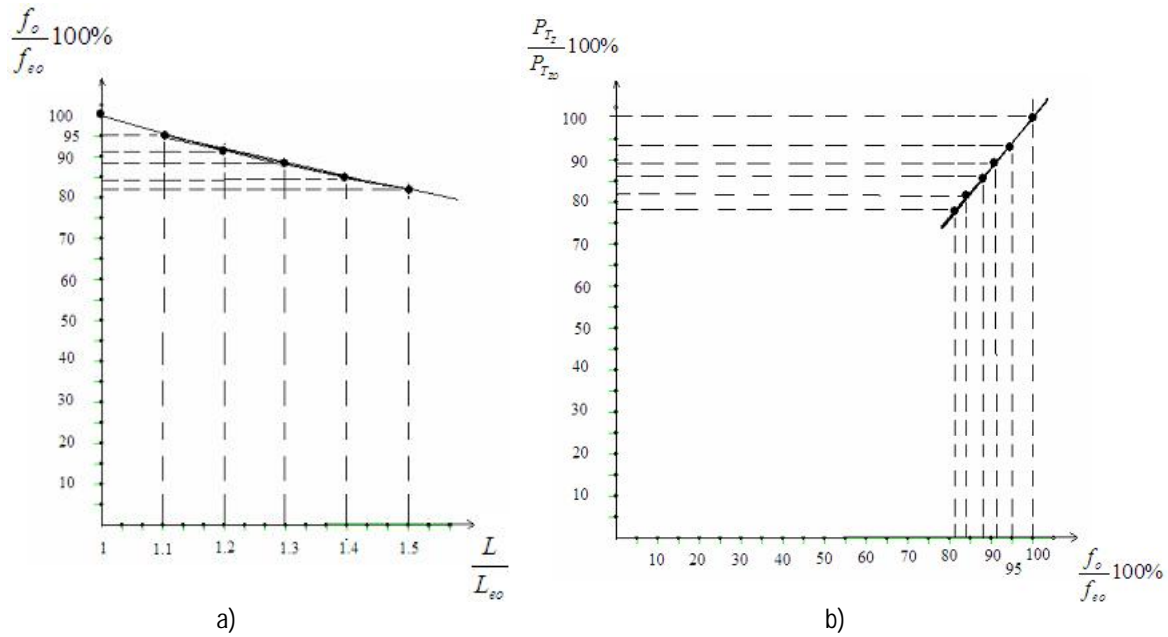

Fig. 5. Relative change: a) dependence of the change frequency of changes on the inductance $f = F(L)$, b) dependence of the power losses of IGBT module of the change frequency $P_{Tz} = F(f)$.

B. Estimation of the switching losses in Semisiel program

Based on the defined power, voltage and frequency in SemiSiel simulation program defines the topology of the converter with choice on the transistors modules, [11]. We choose semiconductor IGBT module SKM195GB066D with $V_{cesat}=1.67V$ and diode voltage $V_F=1.45V$. Also, consider two topologies: cooling air with flow $80m^3/h$ and cooling water with flow $6 l/min$. In the Table 5 shows the losses of power by semiconductor module for two proposed topologies obtained in SemiSiel simulation program.

Table 5: Power losses

	SKM195GB066D) air cooling 80 m ³ /h current	SKM195GB066D water cooling 6 l/min current
$P_{cond tr}$	92 W	88 W
$P_{sw tr}$	4.82 W	3.90 W
P_T	96 W	92 W
$P_{cond d}$	0.00 W	0.00 W
$P_{sw d}$	0.94 W	0.51 W
P_d	0.94 W	0.51 W
P_{tot}	778 W	737 W

P_{condtr} , P_{swtr} , P_T is conduction power losses, switching power losses and total power losses on the transistor in IGBT module.

$P_{cond d}$, $P_{sw d}$, P_d is conduction power losses, switching power losses and total power losses on the diode in the IGBT module.

$P_{tot} = P_{cz}$ is total power losses on the converter.

Table 5 shows that:

- Switching power losses $P_{swtr}+P_{swd}$ on IGBT transistor module (for system with cooling) are smaller of those obtained in Table 2, (P_{Tsw}),
- Total power losses decrease in topology with water cooling to 5%.
- Total power losses is a sum of the switching losses and conduction losses on the transistor and the diode.

Used on system with water cooling, total power losses are the decrease. IGBT module SKM195GB066 has positive temperature coefficient, for the voltage collector emitter [7]. The voltage collector emitter in turn on state is $V_{cesat} = 1.45V$ on junction temperature $T_j = 25^\circ C$, and $V_{cesat} = 1.7V$ on junction temperature $T_j = 150^\circ C$. Because the power losses in turn on state dependent from voltage V_{cesat} , this means that of higher operating temperature power losses are higher. So, system with water cooling reducing the junction temperature and reduces power losses.

C. Experimental results

Here us interested total power losses in a practical realized power converter obtained with measurement.. Topology of full IGBT bridge power converter with serial resonant load by values of the magnitudes as in the Table 1 and 3, is used for controlling of induction heating device. The induction heating device is used for melting on the work piece copper with mass $6kg$. The metal piece acts as a secondary transformer winding and load at the same time and can be modelled as series resonant RLC circuit, [5]. This resonant output load changes during the metal treatment and has a dynamics that depends and affect the operation of the resonant converter. With such loads, output power of the converter depends not only on the voltage rms value, but on the frequency as well. The dynamics of the induction heating process is affected by the values of the primary inductance L and the resonant load. As the resonant frequency is determined by L and C , the operating frequency has to be changed to maintain the constant output power. With

such loads it is necessary to constantly regulate the output power by adjusting the operating frequency.

The Table 6 is shows values of the magnitudes obtained with measurement in practical realized power converter.

Table 6: Power losses in a practical realized power converter in mode of induction heating device obtained with measurement

I_{DClink} (A)	U_{DClink} (V)	P_{DC} (kW)	I_{outrms} (A)	U_{outrms} (V)	$S_{out} \approx P_{out}$ (kVA)	η_{conv} (%)
220	60	13.2	225	55	12.38	93

Table 6 shows that:

- $P_{DC} = I_{DClink} U_{DClink}$ is the power on the DClink circuit, this is input power in the converter,
- $S_{out} \approx P_{out} = I_{outrms} U_{outrms}$ is the apparent output power on the converter, because converter work close to resonance frequency, apparent output power is close to the active power,
- $P_{DC} - P_{out} = 820W$ is total power losses on the converter, and she is close to total power losses in the Table II, III and V,
- $\frac{P_{out}}{P_{DC}} = \eta_{conv} = 93.8\%$ is efficiency on the power converter.

3. Conclusion

In the paper the researching for estimation on the switching losses to IGBT bridge converter with the output serial resonant load is given. The results to the switching losses, estimated by simulation are compared with the results in a practical realized converter. The results from the researching shows that the estimation on the total switching power losses obtain with simulation are almost identical with the same in an practical realized converter. Also, the researching shows that the switching power losses is frequency depend, and they is increased with increasing to the frequency. The work of the resonant converter on frequency higher than resonant frequency ensure the switching of IGBT transistors in the bridge with zero voltage turn on (ZVS). Turn on of IGBT transistors in conditions on ZVS reduces the switching power losses. The results in this paper are good basis for determining on the switching power losses and can be used for optimal design of the power converter.

*Recommended for publication
of Editorial board*

References

- W. B. Williams, *Principles and Elements of Power Electronics*, University of Strathclyde, Glasgow, 2006.
- R. W. Ericson, *Fundamentals of Power Electronics*, Kluwer, 2002.
- AN9012: *Induction Heating System Topology Review*, Fairchild, July, 2000.
- Jang Y. and Jovanovic M. M., *A new PWM ZVS full-bridge converter*, IEEE Trans. Power Electron., vol. 22, no. 3, pp. 987-994, May 2007.
- G.Stefanov, L.Karadzinov, T.Czekov,, *Design of an IGBT Bridge Converter for Serial Resonant Load* 14th International Power Electronics and Motion Control Conference, EPE-PEMC 2010, 978-1-4244-7854-5/10/\$26.00 ©2010 IEEE, T9 19 – 26, Ohrid, R.Macedonia
- M.Orban, M.Orban, K.Ianakiev, E.Kartzelin, *Static converters and thir application*, St. "Ivan Rilski" Publishing house, University of mining and geology, Sofia, 2002
- "SEMİKRON *Power Electronics News 2008*".
- Viriya Pichetjamroen,. Naras Yongyuth, and Kouki Matsuse, *Analysis of Two Continuous Control Regions of Conventional Phase Shift And Transition Phase Shift for Induction Heating Inverter under ZVS and NON-ZVS Operation*, IEEE, 2008.
- PowerSim 8.0.5 *simulation program*.
- G. Stefanov, L.Karadzinov, N. Mojsoska, *Calculation of Induction Device with Simulation Methods*, MGU International Scientific Conference, Sofia, VOL. 53, pp. 160-165, 19-20.10.2010.
- SEMISEL Thermal calculator & simulator, www.semikron.com, semisel.semikron.com