



January 2020

## A Study Of The Feasibility Of Growth, Extraction, And Industrial Scale Up Processing Of Microalgae Lipids.

Jasmine Oleksik

Follow this and additional works at: <https://commons.und.edu/theses>

---

### Recommended Citation

Oleksik, Jasmine, "A Study Of The Feasibility Of Growth, Extraction, And Industrial Scale Up Processing Of Microalgae Lipids." (2020). *Theses and Dissertations*. 3115.  
<https://commons.und.edu/theses/3115>

This Thesis is brought to you for free and open access by the Theses, Dissertations, and Senior Projects at UND Scholarly Commons. It has been accepted for inclusion in Theses and Dissertations by an authorized administrator of UND Scholarly Commons. For more information, please contact [und.common@library.und.edu](mailto:und.common@library.und.edu).

A STUDY OF THE FEASIBILITY OF GROWTH, EXTRACTION, AND  
INDUSTRIAL SCALE UP PROCESSING OF MICROALGAE LIPIDS

By

Jasmine LouAnn Kreft  
Bachelor of Science, University of North Dakota, 2017

A Thesis

Submitted to the Graduate Faculty

Of the

University of North Dakota

In partial fulfillment of the requirements

For the degree of

Master of Science

Grand Forks, North Dakota

May  
2020



This thesis, submitted by Jasmine Kreft in partial fulfillment of the requirements for the Degree of Master of Science from the University of North Dakota, has been read by the Faculty Advisory Committee under whom the work has been done and is hereby approved.

---

Dr. Wayne Seames

---

Dr. Yun Ji

---

Dr. Alena Kubatova

This thesis is being submitted by the appointed advisory committee as having met all of the requirements of the School of Graduate Studies at the University of North Dakota and is hereby approved.

---

Chris Nelson  
Associate Dean of the School of Graduate Studies

---

Date

## PERMISSION

Title	A Study of the Feasibility of Growth, Extraction, and Industrial Scale Up Processing of Microalgae Lipids
Department	Chemical Engineering
Degree	Master of Science

In presenting this thesis in partial fulfillment of the requirements for a graduate degree from the University of North Dakota, I agree that the library of this University shall make it freely available for inspection. I further agree that permission for extensive copying for scholarly purposes may be granted by the professor who supervised my thesis work or, in his absence, by the chairperson of the department or the dean of the School of Graduate Studies. It is understood that any copying or publication or other use of this thesis or part thereof for financial gain shall not be allowed without my written permission. It is also understood that due recognition shall be given to me and to the University of North Dakota in any scholarly use which may be made of any material in my thesis.

Jasmine Krefth  
May 1, 2020

## TABLE OF CONTENTS

LIST OF FIGURES.....	viii
LIST OF TABLES.....	ix
LIST OF DRAWINGS.....	x
ACKNOWLEDGEMENTS.....	xi
ABSTRACT.....	xii
CHAPTER I.....	1
1. INTRODUCTION.....	2
CHAPTER II.....	6
ABSTRACT.....	7
1. INTRODUCTION.....	7
2. EXPERIMENTAL METHODS AND MATERIALS.....	10
2.1 Solvent and microalgae to Solvent Ratio Selection.....	10
2.2 Design.....	11
2.3 Economic Analysis.....	11
2.4 Process Design Assumptions.....	13
2.5 Equipment Design Assumptions.....	14
2.6 Utility Assumptions.....	15
3. RESULTS AND DISCUSSION.....	16
3.1 Process Design.....	16
3.2 Broad Cost Estimates.....	23
3.3 Operating Cost Estimates.....	27
3.4 Revenues.....	34
3.5 Overall Profitability.....	35
4. CONCLUSION.....	39
5. ACKNOWLEDGEMENTS.....	41
CHAPTER III.....	42
ABSTRACT.....	43
1. INTRODUCTION.....	44
2. MATERIALS AND METHODS.....	46
2.1 Materials and Reagents.....	46
2.2 Experimental Setup.....	48
2.3 Experimental Methods.....	49
2.4 Analytical Methods.....	51
3. RESULTS AND DISCUSSION.....	53
3.1 TCA and Ultimate Analysis.....	53
3.2 HPLC Analysis.....	56
4. CONCLUSIONS.....	59
5. ACKNOWLEDGEMENTS.....	59
CHAPTER IV.....	60
ABSTRACT.....	61

1. INTRODUCTION.....	62
2. MATERIALS AND METHODS.....	64
2.1 Materials and Reagents.....	64
2.2 Experimental Methods.....	66
2.3 Experimental Methods.....	67
2.3.1 Grinding Study Methods.....	69
2.3.2 Microalgae to Solvent Ratio Study Methods.....	71
2.3.3 Microwave Study Methods.....	71
2.3.4 Sonication Study Methods.....	72
2.3.5 Temperature Study Methods.....	72
2.3.6 In-Situ Transesterification Study Methods.....	73
2.3.7 Optimization Study Methods.....	73
2.4 Analytical Methods.....	74
3. RESULTS AND DISCUSSION.....	75
3.1 Grinding Study Results.....	75
3.2 Microalgae-to-Solvent Ratio Study Results.....	76
3.3 Microwave Study Results.....	83
3.4 Sonication Study Results.....	86
3.5 Temperature Study Results.....	88
3.6 In-Situ Transesterification Study.....	94
3.7 Optimization Study Results.....	99
4. CONCLUSIONS.....	103
5. ACKNOWLEDGEMENTS.....	104
CHAPTER V.....	105
1. CONCLUSION.....	106
APPENDIX A: HETERTROPHIC PROCESS.....	A-1
A.1 DETAILED PROCESS DECRPTION.....	A-2
APPENDIX B: AUTOTROPHIC PROCESS.....	B-1
B.1 DETAILED PROCESS DECRPTION.....	B-2
APPENDIX C: HETERTROPHIC PROCESS.....	C-1
C.1 MAJOR EQUIPMENT LIST.....	C-2
APPENDIX D: AUTOTROPHIC PROCESS.....	D-1
D.1 MAJOR EQUIPMENT LIST.....	D-2
APPENDIX E: OPERATIONAL CASH FLOW SHEETS.....	E-1
E.1 HETERTROPHIC PROCESS.....	E-2
E.2 AUTOTROPHIC PROCESS.....	E-3
APPENDIX F: CAPITAL COST SUMMARY TABLES.....	F-1
F.1 HETERTROPHIC PROCESS.....	F-2
F.2 AUTOTROPHIC PROCESS.....	F-13
APPENDIX G: INCREMENTAL NPV.....	G-1
G.1 INCREMENTAL NPV.....	G-2

APPENDIX H: HETEROTROPHIC PROCESS DRAWINGS .....	H-1
APPENDIX I: AUTOTROPHIC PROCESS DRAWINGS .....	I-1
APPENDIX J: GROWTH MEDIA REQUIREMENTS .....	J-1
J.1 BOLD'S BASAL MEDIA .....	J-2
J.2 HETEROTROPHIC BASAL MEDIA .....	J-2
APPENDIX K: HPLC RESULTS .....	K-1
K.1 HPLC HMB CHROMATOGRAPH .....	K-2
APPENDIX L: OIL EXTRACTION PROTOCOL .....	L-1
L.1 GRINDING STUDY PROCEDURE .....	L-2
L.2 MICROALGAE-TO-SOLVENT RATIO STUDY PROCEDURE .....	L-3
L.3 MICROWAVE STUDY PROCEDURE .....	L-5
L.4 SONICATION STUDY PROCEDURE .....	L-6
L.5 TEMPERATURE STUDY PROCEDURE .....	L-7
L.6 IN-SITU TRANSESTERIFICATION STUDY PROCEDURE .....	L-9
APPENDIX M: OIL EXTRACTION EXPERIMENT LIST .....	M-1
M.1 EXPERIMENT LIST .....	M-2
APPENDIX N: REFERENCE LIST .....	N-1
N.1 REFERENCES .....	N-2



## LIST OF FIGURES

FIGURE II-1: Heterotrophic Microalgae Fatty Acid Based Oil Extraction PFD.....	19
FIGURE II-2: Autotrophic Microalgae Fatty Acid Based Oil Extraction PFD.....	20
FIGURE II-3: Extraction Efficiency of Fatty Acid Based-Oils from Autotrophic Microalgae Based on Solvent Performance.....	25
FIGURE II-4: Extraction Efficiency of Fatty Acid Based-Oils from Autotrophic Microalgae Based on Solvent to Microalgae Ratio.....	26
FIGURE III-1: Thermal Carbon Analysis Results for the Total Eluded Carbon at Each Temperature Fraction for Each Feedstock.....	54
FIGURE III-2: Lipid Concentration for Microwave Samples throughout Growth...	58
FIGURE IV-1: Small Batch Reactor.....	67
FIGURE IV-2: Effect of Cell Wall Rupture due to Grinding Gravimetric Results...	76
FIGURE IV-3: Effect of Microalgae to Solvent Ratio with Microwave Gravimetric Results.....	78
FIGURE IV-4: Effect of Microalgae to Solvent Ratio with Sonication Gravimetric Results.....	80
FIGURE IV-5: Effect of Microalgae to Solvent Ratio with Sonication Thermal Carbon Analysis Results.....	80
FIGURE IV-6: Effect of Solvent to Microalgae Ratio with Sonication Gravimetric Results.....	81
FIGURE IV-7: Effect of Solvent to Microalgae Ratio with Sonication Thermal Carbon Analysis Results.....	82
FIGURE IV-8: Effect of Microwave Facilitated Extraction Gravimetric Results.....	84
FIGURE IV-9: Effect of Microwave Facilitated Extraction Thermal Carbon Analysis Results.....	85
FIGURE IV-10: Effect of Temperature Facilitated Extraction Gravimetric Results.....	90
FIGURE IV-11: Effect of Temperature Facilitated Extraction Thermal Carbon Analysis Results.....	91
FIGURE IV-12: Effect of Temperature Facilitated Extraction Gravimetric Results.....	93
FIGURE IV-13: Effect of Temperature Facilitated Extraction Thermal Carbon Analysis Results.....	94
FIGURE IV-14: Effect of In-Situ Transesterification Gravimetric Results.....	96
FIGURE IV-15: Effect of In-Situ Transesterification Thermal Carbon Analysis Results.....	97
FIGURE IV-16: Effect of Optimized Conditions Gravimetric Results.....	101
FIGURE IV-17: Effect of Optimized Conditions Thermal Carbon Analysis Results.....	102

## LIST OF TABLES

TABLE II-1: Raw Material Requirements.....	18
TABLE II-2: Utility Requirements and Costs.....	21
TABLE II-3: Fatty Acid Oil Composition from Each Process.....	24
TABLE II-4: Equipment Table for Heterotrophic Process.....	28
TABLE II-5: Equipment Table for Autotrophic Process.....	29
TABLE II-6: Operating Cost Summary.....	30
TABLE II-7: Nutrient Cost Chart and Media Requirements.....	31
TABLE II-8: Revenue Projection for the Heterotrophic and Autotrophic Process.....	35
TABLE II-9: Economic Cash Flow Sheet for the Heterotrophic Process.....	37
TABLE II-10: Economic Cash Flow Sheet for the Autotrophic Process.....	38
TABLE III-1: Ultimate Analysis of the 3 Microalgae Feedstock.....	55
TABLE III-2: Increase in Lipids Production for Each Starting Concentration.....	59
TABLE IV-1: A Summary of Extraction Experiments Performed.....	70
TABLE IV-2: Comparison of Extraction Experiment Results.....	103

## LIST OF DRAWINGS

DRAWING H.1: Heterotrophic Microalgae Oil Extraction I/O Diagram.....	H-1
DRAWING H.2: Heterotrophic Microalgae Oil Extraction BFD.....	H-2
DRAWING H.3: Heterotrophic Microalgae Oil Extraction BFD.....	H-3
DRAWING H.4: Heterotrophic Microalgae Oil Extraction BFD.....	H-4
DRAWING H.5: Heterotrophic Microalgae Oil Extraction PFD.....	H-5
DRAWING H.6: Heterotrophic Microalgae Oil Extraction PFD.....	H-6
DRAWING H.7: Heterotrophic Microalgae Oil Extraction PFD.....	H-7
DRAWING H.8: Heterotrophic Microalgae Oil Extraction PFD.....	H-8
DRAWING H.9: Heterotrophic Microalgae Oil Extraction PFD.....	H-9
DRAWING H.10: Heterotrophic Microalgae Oil Extraction PFD.....	H-10
DRAWING H.11: Heterotrophic Microalgae Oil Extraction PFD.....	H-11
DRAWING H.12: Heterotrophic Microalgae Oil Extraction PFD.....	H-12
DRAWING H.13: Heterotrophic Microalgae Oil Extraction PFD.....	H-13
DRAWING H.14: Heterotrophic Microalgae Oil Extraction PFD.....	H-14
DRAWING I.1: Autotrophic Microalgae Oil Extraction I/O Diagram.....	I-1
DRAWING I.2: Autotrophic Microalgae Oil Extraction BFD.....	I-2
DRAWING I.3: Autotrophic Microalgae Oil Extraction BFD.....	I-3
DRAWING I.4: Autotrophic Microalgae Oil Extraction BFD.....	I-4
DRAWING I.5: Autotrophic Microalgae Oil Extraction PFD.....	I-5
DRAWING I.6: Autotrophic Microalgae Oil Extraction PFD.....	I-6
DRAWING I.7: Autotrophic Microalgae Oil Extraction PFD.....	I-7
DRAWING I.8: Autotrophic Microalgae Oil Extraction PFD.....	I-8
DRAWING I.9: Autotrophic Microalgae Oil Extraction PFD.....	I-9
DRAWING I.10: Autotrophic Microalgae Oil Extraction PFD.....	I-10
DRAWING I.11: Autotrophic Microalgae Oil Extraction PFD.....	I-11
DRAWING I.12: Autotrophic Microalgae Oil Extraction PFD.....	I-12
DRAWING I.13: Autotrophic Microalgae Oil Extraction PFD.....	I-13
DRAWING I.14: Autotrophic Microalgae Oil Extraction PFD.....	I-14
DRAWING I.15: Autotrophic Microalgae Oil Extraction PFD.....	I-15
DRAWING I.16: Autotrophic Microalgae Oil Extraction PFD.....	I-16

## ACKNOWLEDGMENTS

I wish to express my sincere appreciation to the members of my advisory Committee, Dr. Alena Kubatova and Dr. Yun Ji, for their guidance and support during my time at the University of North Dakota. I would like to thank the UND Chemical Engineering Department for the support during my undergraduate and graduate time in the department.

I would like to thank the National Science Foundation International Research Experience for Students grant for providing the funding for to complete the present work and provide the opportunity for collaborative research with the University of Leeds.

I would like to thank Ian Foerster for his contributions to this work and the guidance he provided throughout this research. I would also like to thank Dave Hirschmann for his assistance in my laboratory work. I would like to thank the members of my plant design partners, Eric Moe and Nick Garcia, for their efforts towards the design aspect of this work. I would also like to thank our advisor for the work, Dr. Edward Kolodka, for his guidance.

I would like to thank my friends and family for all the support and encouragement throughout graduate school. I would especially like to thank my husband, John Oleksik, for his love and support throughout this process.

Finally, I would like to thank my advisor, Dr. Wayne Seames, for all his advice, patience, and support.

## ABSTRACT

The interest in microalgae as a plausible alternative to crop oils as a raw material in the form of triglycerides and free fatty acids (FA oils) for renewable fuels and chemicals is increasing and it is a widespread research topic at the lab scale. Microalgae contain a higher lipid content on a dry weight basis compared to oilseeds such as soybeans. Additionally, the growth and cultivation cycle of microalgae is 15 days, in comparison to soybeans where the cycle occurs once or twice annually. Despite these advantages, to date it has been uneconomical to produce microalgae oils in a world-scale facility due to limitations in cultivating microalgae at commercial scales and the inefficiency and high costs to extract the lipids.

Extensive research has been done to identify ideal microalgae strains in order to increase lipids production, biomass growth rate and density, and to minimize nutrient consumption, environmental impacts, invasive biologicals and other external factors<sup>1</sup>. Of the hundreds of different strains of microalgae commercially available, a strain which has proven to yield a high lipids content is *Chlorella Vulgaris* which is also one of the fastest growing microalgae strains<sup>2</sup>. Additionally, this strain of microalgae has been found to be amenable to heterotrophic adaptation<sup>3</sup>.

Recent developments suggest that the use of heterotrophic microalgae may be economically feasible for large-scale oil production. Traditional autotrophic microalgae cultivation at the industrial scale is challenging because either numerous photo bioreactors or large open ponds are required to disperse photons throughout the feedstock for efficient

photosynthesis but present a challenge because of the considerable economic investment to procure the large quantity necessary for commercial scale FA oil production. Recent research has explored the potential of transforming autotrophic microalgae to heterotrophic microalgae, negating the light dependence of the studied strains and thus relieving this key scale-up constraint. The transition to heterotrophic halts the photosynthesis process, but requires an organic carbon source to provide energy, as the heterotrophic strain of microalgae is unable to assimilate carbon dioxide as an energy source via photosynthesis<sup>4</sup>. The transition from autotrophic to heterotrophic has been shown to increase the FA oil content of the microalgae by replacing the chlorophyll cells produced during photosynthesis with additional lipids<sup>5,6</sup>.

This thesis presents three studies. Each addresses a different challenge related to the commercial feasibility of fatty acid-based oil extraction from microalgae. First, a comparative scoping study was performed analyzing the feasibility of an industrial scale process plant for the growth and extraction of oil from microalgae from autotrophic and heterotrophic subspecies of the same microalgae strain. Processes were developed at the preliminary design level using heterotrophic subspecies and autotrophic subspecies of *Chlorella Vulgaris*. AACE Class 4 cost estimates and economic analyses were performed. This study concludes that processes based on heterotrophic microalgae are more likely to reach economic feasibility than processes using autotrophic microalgae. However, a few barriers still remain to achieve free market economic viability.

The second study provides thermal carbon analysis, as well as ultimate analysis to showcase the differences between the autotrophic and heterotrophic strains of *Chlorella Vulgaris* grown in-house at the University of North Dakota, and an additional autotrophic strain of *Chlorella Vulgaris* obtained from the University of Leeds. Both analyses indicate an increased lipids content in the heterotrophic microalgae when directly compared to autotrophic microalgae.

Finally, a study was performed of the most attractive of the various techniques previously reported for optimization of microalgae lipid extraction using an autotrophic version of *Chlorella Vulgaris*. The best method was then applied to a heterotrophic version of the same microalgae strain for comparison. The factors which were able to be optimized were: 1) the effect of three different solvents: methanol, ethanol, and hexane; 2) the effect of a mechanical pre-treatment of ball mill with a variety of grinding speeds; 3) the effect of various microalgae to solvent ratios; 4) the effect on extraction when the process is facilitated by microwave; 5) the effect on extraction when the process is facilitated by sonication; 6) the effect on extraction when the process is facilitated by temperature; and 7) the effect of in-situ transesterification on extraction efficiency.

## CHAPTER I. INTRODUCTION



## *1. Introduction*

Microalgae has been proposed by many as a potential source of fatty acid-based oils, in the form of lipids, that can be converted into renewable replacements for a number of petroleum derived fuels and chemicals<sup>7-9</sup>. By utilizing microalgae as the feedstock, the land area required to produce this oil is significantly reduced compared to oilseed crops. The short growing cycle of microalgae, which has a two-week growing and cultivation cycle, maximizes the number of harvesting cycles per year compared to harvesting once or twice a year due to the lengthy growing season when using an oilseed crop<sup>10</sup>. Despite these advantages, to date it has been uneconomical to produce microalgae oils in a world-scale facility due to limitations in cultivating microalgae at commercial scales and the inefficiency and high costs to extract the lipids.

Traditionally, the microalgae are grown in an autotrophic environment where the microalgae require an inorganic carbon source, such as carbon dioxide, combined with a light source to create energy via photosynthesis. Autotrophic microalgae cultivation at the industrial scale is challenging because either numerous photo bioreactors or large open ponds are required to disperse photons throughout the feedstock for efficient photosynthesis. The best photo bioreactors currently available are small-diameter, clear plug flow reactors (PFRs) or polymer-bag batch reactors. Both types present a challenge because of the considerable economic investment to procure the large quantity of reactors and handle the substantial quantities of water and nutrients necessary for commercial scale FA oil production<sup>11</sup>.

If the strain of microalgae used was non-light dependent it could negate the requirement for massive numbers of clear photo bioreactors or open ponds at the industrial

scale. Recent research has demonstrated the potential of transforming autotrophic microalgae to heterotrophic microalgae, negating the light dependence of the studied strains<sup>6</sup>. The transition to heterotrophic halts the photosynthesis process and requires an organic carbon source to provide energy, as the heterotrophic strain of microalgae is unable to assimilate carbon dioxide as an energy source via photosynthesis<sup>2</sup>. Heterotrophic strains also require an outside source of oxygen for cellular respiration.

Because heterotrophic strains can be grown in enclosed tank reactors, the required capital investment, land mass, and maintenance will all be substantially reduced due to the drastic difference in the number of growth reactors, water, and nutrients required compared to the autotrophic strains. This in turn increases the feasibility of scale-up. The transition from autotrophic to heterotrophic has also been shown to increase the FA oil content of the microalgae by replacing the chlorophyll cells produced during photosynthesis with additional FA oils<sup>5, 6</sup>. One of the goals of my research has been to evaluate the feasibility of heterotrophic microalgae as a fatty acid generation source.

Extensive research has been done to identify ideal microalgae strains in order to increase lipids production, biomass growth rate and density, and to minimize nutrient consumption, environmental impacts, invasive biologicals and other external factors<sup>1</sup>. There are hundreds of different strains of microalgae commercially available. A strain which has proven to yield a high lipids content is *Chlorella Vulgaris* which is also one of the fastest growing microalgae strains<sup>2</sup>. Additionally, this strain of microalgae has been found to be amenable to heterotrophic adaptation<sup>3</sup>.

The extraction of lipids from microalgae has been studied extensively at the laboratory scale. However, comprehensive studies of extraction methods with follow-on

techno-economic analysis are lacking. Thus, another goal of my research has been to extend the work of another UND graduate student, Ian Foerster, in order to provide such a study for autotrophic microalgae and perform conditions optimized with autotrophic microalgae with heterotrophic microalgae.

The following three chapters present three studies. Each addresses a different challenge related to the commercial feasibility of fatty acid-based oil extraction from microalgae. Chapter II, “Comparative Scoping Study Report for the Extraction of Microalgae Oils from Two Subspecies of *Chlorella Vulgaris*,” documents a study conducted to evaluate the commercial potential for the production of fatty acid oils from the cultivation and extraction of lipids using a heterotrophic version of the microalgae strain, *Chlorella Vulgaris*. In order to evaluate the heterotrophic strain completely, two process designs were developed, one based on the autotrophic version of the strain and the second based on the heterotrophic version.

Chapter III, “Comparative Study of the Growth of Two Subspecies of *Chlorella Vulgaris*, Autotrophic and Heterotrophic Microalgae for Optimal Lipid Content,” presents a study focused on the growth and transition of the autotrophic strain of *Chlorella Vulgaris* to the heterotrophic strain of *Chlorella Vulgaris*, to study the energy consumption of heterotrophic versus autotrophic production. Inputs, growth rates, and other factors were quantified and are available to assist in future studies in this area.

Chapter IV, “Optimization of Triglycerides and Free Fatty Acid Extraction from Autotrophic and Heterotrophic Strains of The Microalgae *Chlorella Vulgaris*,” documents a study of techniques and operating parameters for the optimization of microalgae lipid extraction using an autotrophic version of *Chlorella Vulgaris*. These optimum conditions

were then applied to a heterotrophic version of the same microalgae strain for direct comparison.

**CHAPTER II. COMPARITIVE SCOPING STUDY REPORT FOR THE EXTRACTION OF  
MICROALGAE OILS FROM TWO SUBSPECIES OF CHLORELLA VULGARIS**

## *Abstract*

The production of microalgae as a fatty acid oil resource for use in biofuels production is a widespread research topic at the lab scale. Microalgae contain a higher lipid content on a dry weight basis compared to oilseeds such as soybeans. Additionally, the growth and cultivation cycle of microalgae is 15 days, in comparison to soybeans where the cycle occurs once or twice annually. However, to date it has been uneconomical to produce microalgae oils in a world-scale facility due to limitations in cultivating microalgae at commercial scales. Recent developments suggest that the use of heterotrophic microalgae may be economically feasible for large-scale oil production. To assess this feasibility, a comparative scoping study was performed analyzing the feasibility of an industrial scale process plant for the growth and extraction of oil from microalgae. Processes were developed at the preliminary design level using heterotrophic subspecies and autotrophic subspecies of *Chlorella Vulgaris*. AACE Class 4 cost estimates and economic analyses were performed. This study concludes that processes based on heterotrophic microalgae are more likely to reach economic feasibility than processes using autotrophic microalgae. However, a few barriers still remain to achieve free market economic viability.

### *1. Introduction*

Microalgae has been proposed by many as a potential source of fatty acid-based oils, in the form of lipids, that can be converted into renewable replacements for a number of petroleum derived fuels and chemicals<sup>7-9</sup>. By utilizing microalgae as the feedstock, the land area required to produce this oil is significantly reduced. The short growing cycle of microalgae which has a two-week growing and cultivation cycle, maximizes the number

of harvesting cycles per year compared to harvesting once or twice a year due to the lengthy growing season when using a cash crop<sup>10</sup>.

Despite a decade of extensive research and development activities, currently there are no world scale facilities for the production of lipid-based oil extracted from microalgae. Research has been done to identify ideal microalgae strains to increase lipid production, growth rate and growth density, and to minimize nutrient consumption, environmental impacts, invasive biologicals and other external factors<sup>1</sup>. Yet barriers to commercialization remain. One of these is the inability to effectively cultivate microalgae at large scales. Recently, some researchers have explored transforming autotrophic microalgae to heterotrophic microalgae, negating the light dependence of the studied strains.

The transition to heterotrophic halts the photosynthesis process and requires an organic carbon source to provide energy since heterotrophic microalgae are not able to produce energy using the same processes as autotrophic strains which produce an energy source through photosynthesis<sup>4</sup>. However, the transition has been shown to increase the lipid content of the microalgae by replacing the chlorophyll cells produced during photosynthesis with lipids and, more importantly, eliminates one of the key scale-up barriers of autotrophic microalgae cultivation. If the strain of microalgae used is non-light dependent it eliminates the requirement of industrial scale, clear photo bioreactors or of open ponds. Further, it has been shown that these heterotrophic strains can be grown efficiently using waste carbon resources, mitigating the need for more valuable sources<sup>5, 6</sup>.

This paper documents a study conducted to evaluate the commercial potential for the production of fatty acid oils from the cultivation and extraction of lipids using a heterotrophic version of the microalgae strain, *Chlorella Vulgaris*. In order to evaluate the

heterotrophic strain completely, two process designs were developed, one based on the autotrophic version of the strain and the second based on the heterotrophic version. In-house lab scale experimental data were generated where such data were not readily available in the literature as required to develop a preliminary process design of the required production facility.

The *Chlorella Vulgaris* strain of microalgae has been proven to yield a high lipid content (15-35 wt%) and is one of the fastest growing microalgae strains<sup>2</sup>. Additionally, this strain of microalgae has been found to be amenable to heterotrophic adaptation<sup>4</sup>. The heterotrophic strain of *Chlorella Vulgaris* should yield a higher lipid content which will generate a larger amount of oil when compared to the autotrophic strain. The microalgae would be grown in trains of reactors for heterotrophic or autotrophic growth. The reactors within each train increase in size and would be designed for microalgae growth to optimize the operating time of the plant.

The lipid extraction method for both the heterotrophic and autotrophic processes can be similar with the only difference being minor variations in the flow rates of each process. The extraction process begins with the separation of the majority of the liquid growth media using a vacuum filter. Subsequently, a press is utilized to remove the majority of the entrained water and to begin to break the cell walls of the microalgae. A grinder is then used to completely destroy the cell walls and expose the lipids. A solvent is used to leach the lipids out of the biomass. Methanol has been shown to be an effective solvent for this purpose<sup>12</sup>. The oil-lean biomass is collected and sold as a high protein animal feedstock by-product. The lipid/methanol mixture is separated using a multi-effect



evaporator from which the fatty acid oils are collected as the primary product and the methanol is recycled as solvent in the oil leaching portion of the process.

The preliminary process design was developed to produce 500,000 kg/yr of fatty acid-based oil from either the heterotrophic or autotrophic strains of the microalgae. This oil can be transformed into biodiesel and other high value chemicals. However, the transformation of the oil was outside of this study and these processes were not developed.

## *2. Experimental methods and materials*

### *2.1 Solvent and Microalgae to Solvent Ratio Selection*

Methanol was chosen as the extraction solvent for the scoping study as a result of an in-house preliminary solvent selection study for optimum fatty acid oil extraction from the strain of microalgae *Chlorella Vulgaris* that will be documented in the Dissertation of Ian Foerster, a UND Chemical Engineering Ph.D. candidate. The solvents utilized for the preliminary study were chloroform, methanol, hexane, acetonitrile, ethanol and DI water. The study was performed by mixing autotrophic microalgae, cultured from a strain purchased from Qingdao Sunrise Trading Co., Ltd., Qingdao, China, and each solvent in a 1:10 ratio (mass to volume) followed by filtration to separate the oils from the biomass.

The 1:10 (mass to volume) algae-to-solvent ratio was chosen as the extraction ratio for the scoping study as a result of an in-house preliminary solvent selection study for optimum fatty acid oil extraction from the strain of microalgae *Chlorella Vulgaris*. The ratios utilized for the preliminary study were the following, 1:3, 1:7, 1:11, 1:15, and 1:19. The study was performed by mixing autotrophic microalgae, cultured from a strain purchased from Qingdao Sunrise Trading Co., Ltd., Qingdao, China, and a solvent in each ratio (mass to volume) followed by gravity filtration to separate the oils for collection.

In both the extraction solvent and solvent to microalgae ratio studies the filtered liquid product was collected, heated to separate the solvent from the product, and weighed. The residual biomass was collected, heated to remove any remaining solvent, and weighed. The gravimetric result of the liquid product was utilized to determine extraction efficiency, and the gravimetric result of the residual biomass was utilized for mass balance closure. It was assumed that comparable extraction efficiency could be accomplished from both heterotrophic and autotrophic strains.

## *2.2 Design*

A preliminary design was developed for each process option. This includes identification and size approximation of all equipment of pump or larger size, organized into the unit operations necessary to transform the raw material and other inputs into the product oil and by-products. In addition to equipment sizing, the design includes an estimate of all required utilities, chemicals, and other resources required by the process. The design is primarily summarized on Process Flow Diagrams (PFDs). Equipment sizing was performed using approximate methods from Ulrich<sup>13</sup> or using the ChemCad<sup>TM</sup> simulation program.

## *2.3 Economic Analysis*

A broad cost estimate (AACE class 4<sup>14</sup>) of the project costs along with estimates of the manufacturing costs, raw material costs, and product revenues were generated at an accuracy level of  $\pm 30\%$ . These cost elements were used to quantify the economic feasibility of the technology. The discounted cash flow return on investment (DCFROR) and net present value at a hurdle rate of 20% (NPV@20%) were estimated to evaluate the economic feasibility of the two process options at a basis date of October 2016. The broad cost

estimate is primarily based on the process flow diagrams (PFD) and the preliminary equipment sizes of the design. The revenues of the process were calculated based on trend price forecasts for product sales, by-product sales, and operating cost credits. To determine the overall potential profitability of each process, an economic cash flow sheet consisting of the process revenues, operating cost, gross profit, depreciation, taxable profit, income tax, nontaxable charges, net profit, and present value was developed based on a 20-year project life.

Depreciation for tax calculations was based on the value of the fixed capital investment (FCI) written off over a period of 17 years with no salvage value using the MACRS method. The taxable income for the process designs was determined by subtracting all expenditures (except capital expenditures) and depreciation charges from the gross income. The income tax was calculated by multiplying the annual taxable income by the tax rate, which was assumed 35% (2017 US tax law basis). The nontaxable charges included the fixed capital investment spread across the estimated project completion time with an estimate for the initial inventory of chemicals plus working capital added to the final project year. The working capital was recovered in the final year.

The annual net profit was determined by subtracting the annual operating expenses, annualized capital costs, and annual taxes from the annual revenue. The present value for each year was determined by discounting the annual net profit using a 20% discount rate to determine the value at the chosen basis date. The NPV@20% was then found as the sum of all of the present values over the life of the project. The DCFROR was determined to be the hurdle rate at which the NPV was equal to zero.

#### *2.4 Process Design Assumptions*

1. The process was designed as a grassroots project with a lifespan of 20 years.
2. The designed process would have an operating factor of 95%.
3. The fatty acid-based oil product should be of sufficient quality for processing into a biofuel in a downstream operation.
4. The growth media in both the autotrophic and heterotrophic processes would enter the growth system already mixed as a concentrated solution in an outside auxiliary area. 95% consumption of Bolds Basal Media and Heterotrophic Basal Media was assumed.
5. Each process would produce 500,000 kilograms per year of oil.
6. 32% of the heterotrophic microalgae and 15% of the autotrophic microalgae can be extracted as lipids<sup>2</sup>.
7. The cell density of heterotrophic microalgae during the growth phase is 20 g/L and of autotrophic microalgae during the growth phase is 8 g/L.
8. CO<sub>2</sub> flow rate: 12mL/min for 200mL Bold Basal Media<sup>15</sup>
9. Seed concentration required for growth is 40 mg/L<sup>16</sup>.
10. 5% methanol is lost on an annual basis and requires a make-up stream.
11. Sucrose solubility in water is 200 g/100 mL<sup>17</sup>.
12. NaNO<sub>3</sub> solubility in water is 91 g/100 mL<sup>18</sup>.
13. CaCl solubility in water is 74 g/100 mL<sup>18</sup>.
14. MgSO<sub>4</sub> solubility in water is 34 1 g/100 mL<sup>18</sup>.
15. NaCl solubility in water is 35 g/100 mL<sup>18</sup>.

## *2.5 Equipment Design Assumptions*

1. A pressure drop of 35 kPa occurs across all unit operations unless otherwise specified.
2. All pumps have an overall efficiency of 70%.
3. Compressor polytropic efficiency is 65%.
4. The surge drum was sized based off an overall length to diameter ratio of 4 to 1.
5. The surge drum was required to have a holding time of 10 minutes.
6. Conveyors are 0.61 m wide, 15 m long, and doubled/redundant.
7. Water removal out of the vacuum filter leaves 5% weight in the outlet solid.
8. Water removal out of the filter press is 95%
9. Heterotrophic reactors were sized with a height to diameter ratio of 2:3<sup>19</sup>.
10. Carbon steel material is sufficient for all equipment.
11. The multi-effect evaporator operates with the first effect at 97 kPa and the final effect at 14 kPa. All effects will have an equal pressure drop over that range.
12. All evaporators have the same heat transfer area<sup>13</sup> and the same volume. The multi-effect evaporator system is small enough such that each separate effect is not individually optimized. The volume of the first effect is sized by utilizing the rule of thumb that a 30-minute residence time will account for 75% of the total volume. For each evaporator effect, the bottom diameter is equal to the height divided by 5 and the top diameter is equal to two times the bottom diameter. A 14 kPa pressure drop occurs across the heat transfer area in each effect of the evaporators.
13. A 62 kPa pressure drop occurs around E-103 and E-1003 due to the stream having to be routed to the beginning of the multi-effect evaporator system.

14. 4 wt% methanol will exit with the biomass stream from the leacher.

### *2.6 Utility Assumptions*

1. Low pressure steam is available at  $T = 160\text{ }^{\circ}\text{C}$  and  $P = 500\text{ kPa}^{20}$ .
2. Process cooling water is available at  $T = 30\text{ }^{\circ}\text{C}$  and  $P = 210\text{ kPa}^{20}$ .
3. Moderately Low Temperature Refrigerated Water is available at  $T = 5\text{ }^{\circ}\text{C}$  and  $P = 210\text{ kPa}^{20}$ .
4.  $\text{CO}_2$  will be externally supplied to the process and priced as a consumable chemical cost.

### *2.7 Economic Assumptions*

1. Values of 400, 543, and 585 were used as the 2004, 2016, and 2012 CEPCI values<sup>13,21</sup> respectively, which were used to bring all economic data to the same basis date
2. The annual maintenance cost was approximated as 6% of the fixed capital investment.
3. No royalties or patent fees are required for this process.
4. A rough planning schedule based on rule of thumb: 30% design, 40% procurement, 30% implementation was used to estimate the project schedule with the longest procurement time used to dictate the schedule.
5. The fixed capital investment is depreciated over a 17-year period.
6. The hurdle rate (minimum acceptable rate of return) is 20%.

### 3. Results and Discussion

#### 3.1 Process Design

Preliminary designs were prepared to generate 500,000 kg/yr of the primary fatty acid-based oil product from either heterotrophic or autotrophic strains of the microalgae *Chlorella Vulgaris*. Figure II-1 and Figure II-2 provide an overview of the heterotrophic and autotrophic process schemes, respectively used in this evaluation. Each process is organized into three major areas. Area 01, shown in Drawing H5 and Drawing I5 through I6 for the heterotrophic and autotrophic processes, respectively, is the Growth and Cultivation Area; Area 02 is the Filtration and Crushing Area, shown in Drawing H6 through H7 and Drawing I7 through I8 for the heterotrophic and autotrophic processes, respectively; and Area 03 is the Extraction and Solvent Separation Area, shown in Drawing H8 through H13 and Drawing I9 through I16 for the heterotrophic and autotrophic processes, respectively. A more detailed display of the preliminary design for each area of the heterogeneous microalgae option is provided on the Process Flow Diagrams (PFDs), Figures H5 through H13 provided in the Supplemental information displays the PFDs for the heterotrophic process while the comparable information for the autotrophic microalgae option is provided on the PFDs in Figures I5 through I16. A detailed process description is also provided in the Supplemental information to explain the PFDs.

The most substantial difference in the design occurs in the Area 01. The growth reactors for the autotrophic case were based on the largest scale commercially available reactor design we could identify at the time of the study, which was 25,000 liters. Based on the capacity of this reactor, the autotrophic case requires 792 reactors. The growth of the *Chlorella Vulgaris* is accomplished by using seeded trains of photo bioreactors, where

each train contains three different sized reactors. The microalgae from each reactor will be transferred into the next reactor after a 14-day growing period. With each transfer, additional growth media will be added to facilitate the growth process. The final stage 25,000-liter reactors are fed to a holding tank that will feed the rest of the process at a constant rate of 45,000 kg/hr.

For the heterotrophic case, the growth reactors were based on the typical size of the reactors used in a world-scale ethanol process which was estimated at 4,500,000 liters. Based on the capacity of this reactor, the heterotrophic case requires 7 reactors. The growth of the *Chlorella Vulgaris* is accomplished by using 3 initial reactors that feed 4 final reactors. At the end of the 15-day growth period each of the final reactors will contain enough microalgae to feed the rest of the process continuously for five days at 4,200 kg/hr. This rate is substantially lower than for the autotrophic case due to differences in biomass density in the final reactors and the lower lipid content of the autotrophic strain. In both cases, these configurations provide a continuous production of biomass that can be fed to the rest of the process.

There were also substantial differences in the inputs required to grow the two different microalgae strains. The estimated annual consumption of these inputs is summarized in Table 1 for both cases. The annual input into the autotrophic process will be higher in comparison to the heterotrophic process to yield the same amount of product due to the lower lipid content in autotrophic microalgae. Utility requirements, summarized in Table 2, were also substantially different due to the additional challenge in the autotrophic reactors.



Table II-1: Raw Material Requirements

<b>Raw Material</b>	<b>Heterotrophic Process (kg/yr)</b>	<b>Autotrophic Process (kg/yr)</b>
<i>Chlorella Vulgaris</i>	2.1	0.45
Carbon Dioxide	-	340,000,000
Sterile Process Air	20,000,000	-
Sucrose	3,200,000	-
Sterile Process Water	210,000	21,000,000

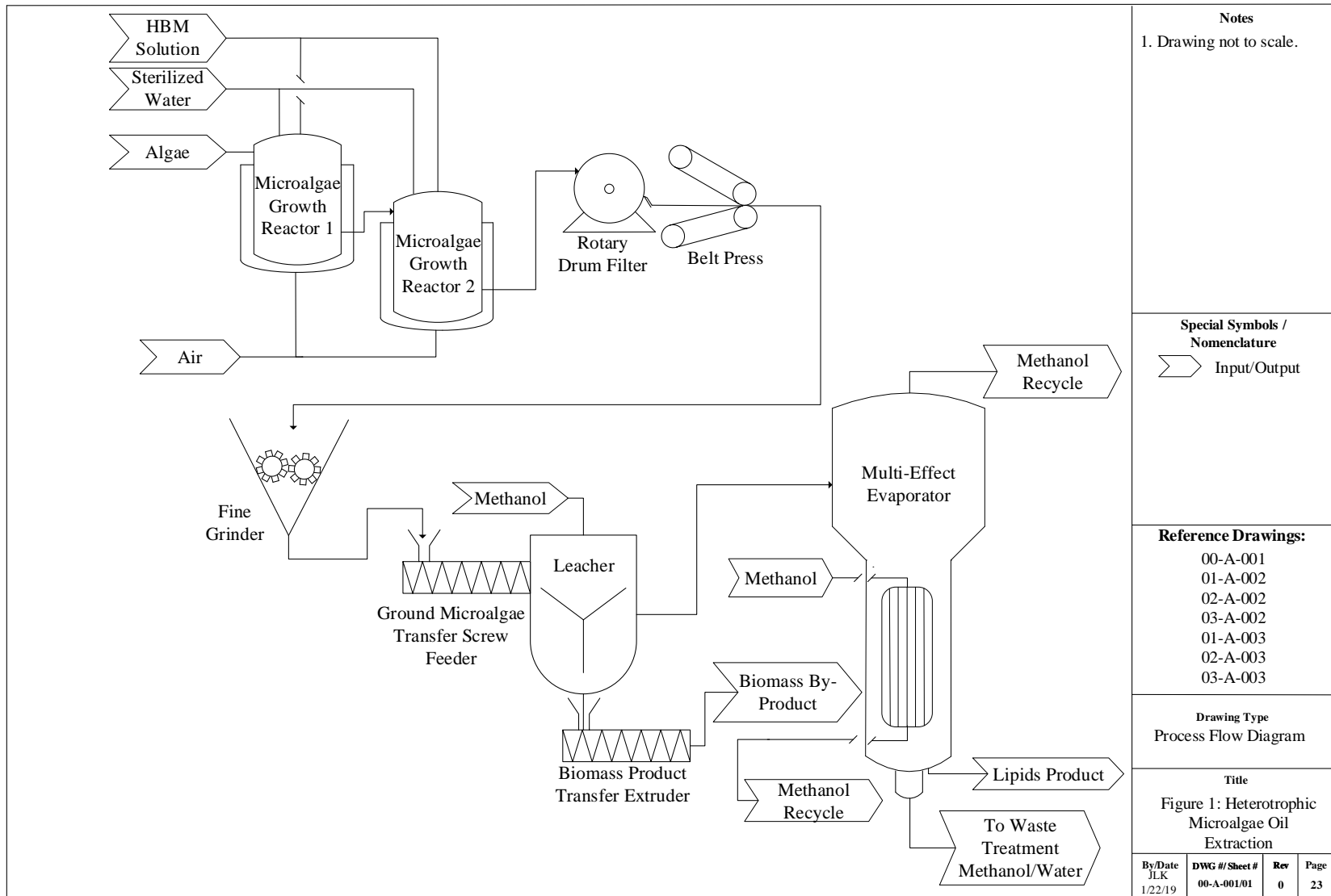

Figure II-1: Heterotrophic Microalgae Fatty Acid Based Oil Extraction Process Flow Schematic

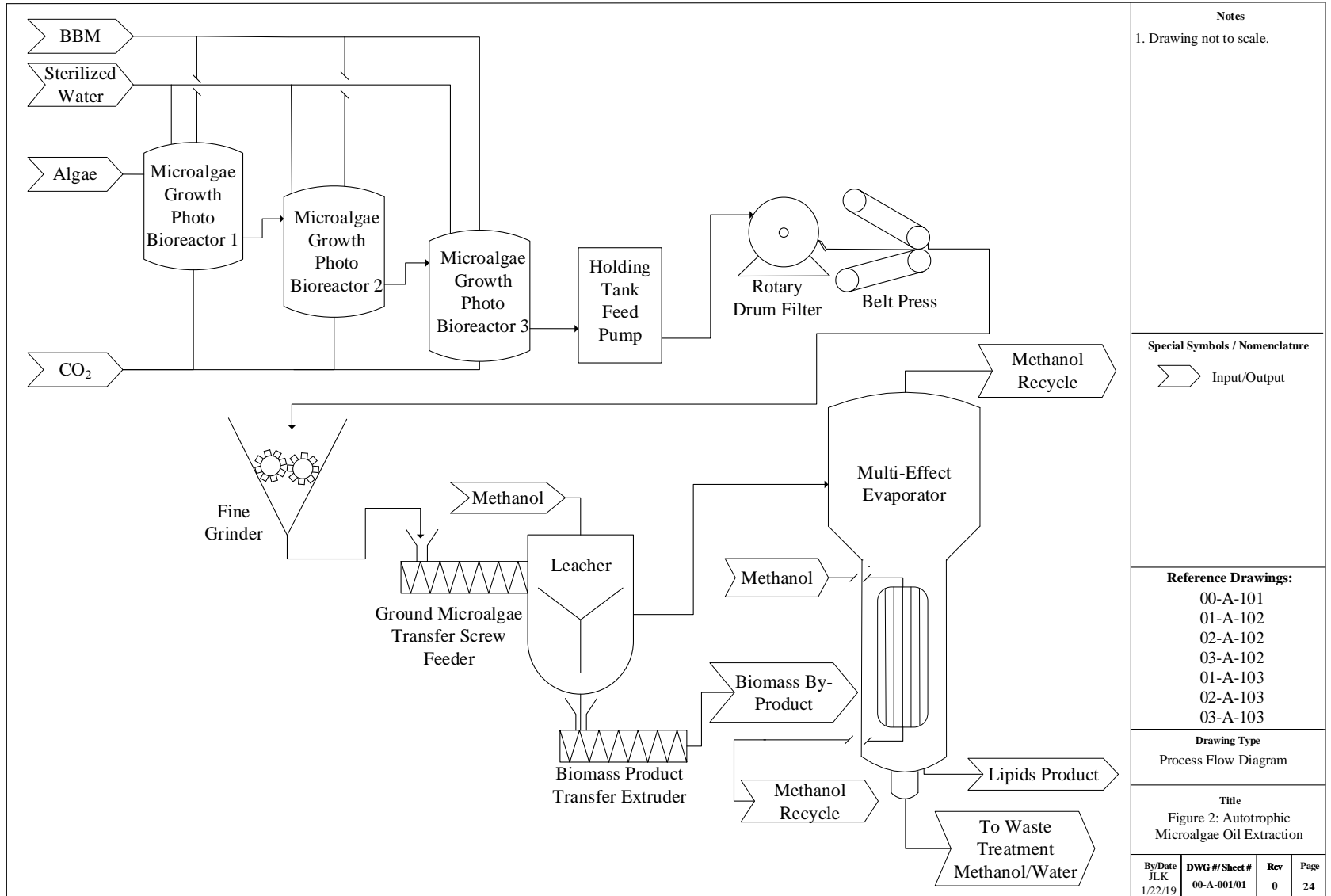

Figure II-2: Autotrophic Microalgae Fatty Acid Based Oil Extraction Process Flow Diagram

Table II-2: Utility Requirements and Costs

Utility Description	Heterotrophic Process		Autotrophic Process	
	Annual Cost (\$/yr)	Requirement	Annual Cost (\$/yr)	Requirement
Electricity	2,200	Amount: 49,000 kWh/yr	12,000	Amount: 270,000 kWh/yr
Low Pressure Steam	350,000	Amount: 12,000,000 kg/yr Supply Temperature: 149°C Supply Pressure: 450 kPa	1,800,000	Amount: 64,000,000 kg/yr Supply Temperature: 149°C Supply Pressure: 450 kPa
Carbon Dioxide	-	-	-	Amount: 340,000,000 kg/yr Supply Temperature: 25°C Supply Pressure: 140 kPa
Process Cooling Water	560	Amount: 38,000,000 kg/yr Temperature: 10°C Pressure: 100 kPa	8,700	Amount: 590,000,000 kg/yr Temperature: 10°C Pressure: 100 kPa
Heating Water	-	-	210,000,000	Amount: 1,500,000,000,000 kg/yr Temperature: 43°C Pressure: 100 kPa
Moderately Low Temperature Refrigerated Water	2,100	Amount: 11,000,000 kg/yr Temperature: 5°C Pressure: 210 kPa	4,500	Amount: 24,000,000 kg/yr Temperature: 5°C Pressure: 210 kPa
Sterile Air	-	Amount: 20,000,000 kg/yr Temperature: 43°C Pressure: 100 kPa	-	Amount: 1,100,000 kg/yr Temperature: 43°C Pressure: 100 kPa
Methanol	17,000	Amount: 34,000 kg/yr Temperature: 43°C Pressure: 100 kPa	660,000	Amount: 590,000 kg/yr Temperature: 25°C Pressure: 100 kPa
<b>Total</b>	<b>\$370,000/yr</b>		<b>\$210 million/yr</b>	

After growth and cultivation in Area 01, the microalgae is dewatered by filtration and then crushed to rupture the cell walls, making oil extraction more efficient in Area 02. These units were designed to operate continuously and are essentially the same for both feedstocks.

Area 03 was designed for the extraction and recovery of the oil from the biomass. The system was designed based on the use of methanol as the extracting solvent. The choice of methanol was based on lab-scale experiments performed with a number of different solvents. A summary of the results of the solvent performance study for the autotrophic strain is shown in Figure II-3. Comparable results were obtained for the heterotrophic strain (results not shown). Additionally, a summary of the results of the study to optimize the solvent-to-microalgae ratio is provided in Figure II-4. A detailed description and documentation of this work is currently being finalized and will be published by Foerster and coworkers<sup>12</sup> in the near future.

In order to recover the oil out of the methanol, a multi-effect evaporator was used to separate the solvent from the desired lipid product. Although this method is relatively energy intensive, it allows us to use a proven method in this comparison study. This is an area where future technology development is likely to improve the efficiency of this process. Annual solvent losses were estimated to be 5% of the recirculating solvent. This section of the process generates 500,000 kg/yr of fatty acid-based oil with the composition summarized in Table 3. 1,000,000 kg/yr and 2,800,000 kg/yr of residual microalgae biomass are produced from the heterotrophic and autotrophic process designs, respectively, as a by-product that was assumed to be sold as a high protein animal feed stock.

### *3.2 Broad Cost Estimates*

A broad estimate of the capital costs for both heterotrophic and autotrophic process designs was completed based on the equipment listed in Tables 4 and 5, respectively. The condensed estimated capital costs for each process are also reported in Tables 4 and Table 5 and include an approximate cost for each piece of equipment, as well as the total capital investment required for the project at an October 2016 basis date. Detailed estimated capital cost tables are included in the supplementary information in Tables S3 and S4.

The cost estimates for the conveyors and fine grinder for this process were determined by acquiring a vendor cost estimate. The remaining equipment was estimated by utilizing the cost charts published by Ulrich and Vasudevan<sup>13</sup>. The Ulrich Cost Data estimates the costs of the equipment to a basis date of 2004. These costs were projected to the basis date using CEPCI values for 2004 and 2016. The total capital investment for the heterotrophic and autotrophic processes were estimated to be \$13 million  $\pm$  40% and \$84 million  $\pm$  40%, respectively.

Area 01 for each process is where the two process designs differ and account for most of the difference in the total capital investment of the two processes. The autotrophic process has higher capital costs due to the large quantity (792) of photobioreactors coupled with the use a more expensive (polypropylene) material of construction than for the heterotrophic bioreactors (7 carbon steel reactors). The designs for Area 02 and Area 03 are nearly identical, except for slightly larger equipment in the autotrophic process due to a higher throughput of raw materials.

*Table II-3: Fatty Acid Oil Compositions from Each Process*

<b>Product</b>	<b>Heterotrophic Process (kg/yr)</b>	<b>Autotrophic Process (kg/yr)</b>
Free fatty acids	500,000	500,000
<b>Components (wt %)</b>		
Palmitic Acid	29%	29%
Palmitoleic acid	2%	2%
Stearic Acid	1%	1%
Oleic Acid	18%	18%
Linoleic Acid	27%	27%
Alpha Linolenic Acid	23%	23%

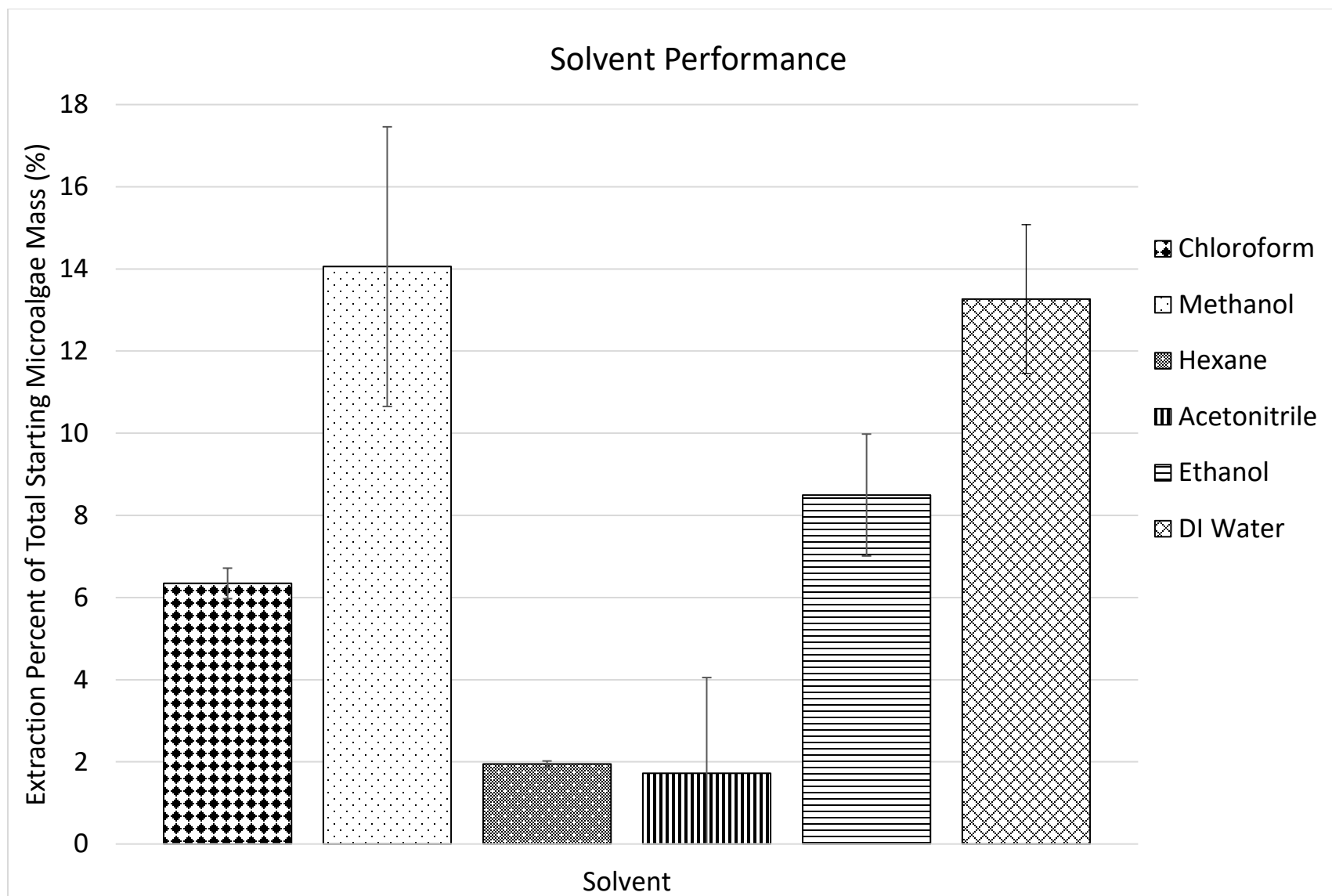
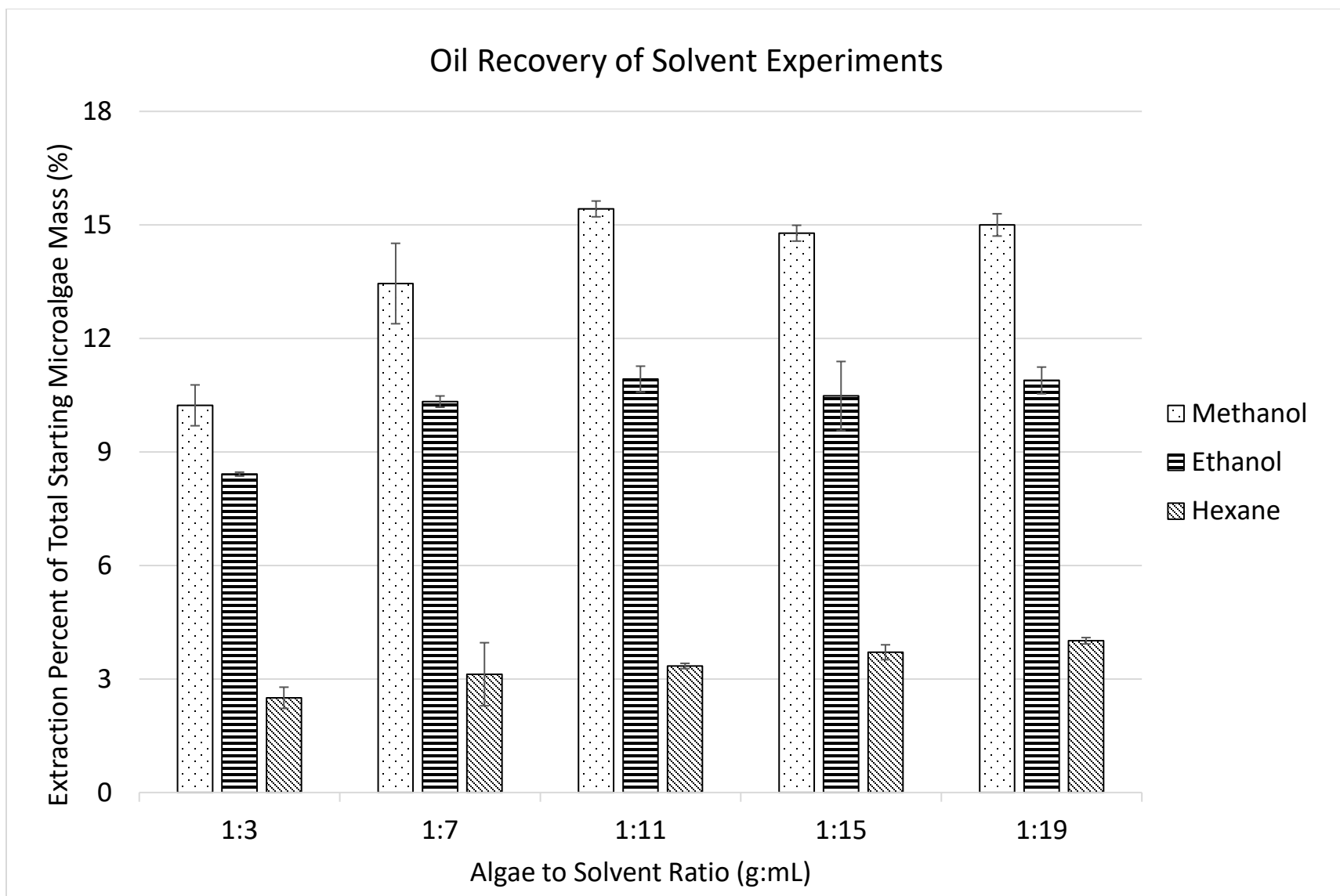

Figure II-3: Extraction Efficiency of Fatty Acid Based-Oils from Autotrophic Microalgae Based on Solvent Performance





*Figure II-4:* Extraction Efficiency of Fatty Acid Based-Oils from Autotrophic Microalgae Based on Solvent to Microalgae Ratio

### 3.3 Operating Cost Estimates

The estimated yearly operating costs for the heterotrophic and autotrophic processes are reported in Table 6. This table shows an itemized analysis of the operating costs. More details of the operating costs are included in the supplementary information in Tables S5 and S6. The total operating costs for the two processes are estimated to be \$3.7 million and \$240 million per year for the heterotrophic and autotrophic processes, respectively at an October 2017 basis date. These costs include raw materials costs, chemical and catalyst costs, operating labor, maintenance costs, and utilities. These costs were based on a plant operating factor of 95%.

The heterotrophic process requires four raw materials: *Chlorella Vulgaris*, sucrose, water, and air. The autotrophic process requires three raw materials: *Chlorella Vulgaris*, process water, and carbon dioxide. The requirements for raw materials are reported in Table 1. Sucrose was priced using commodity trend pricing<sup>22</sup>. The water was priced using a commonly accepted cost<sup>20</sup>. Carbon dioxide was priced using a spot price<sup>23</sup>. The yearly cost for the four raw materials for the heterotrophic process is estimated to be \$880,000 per year. The yearly cost for the three raw materials for the autotrophic process is estimated to be \$7.4 million per year. The difference in the cost of raw materials for the two processes is due to the difference in water consumption. The autotrophic process requires significantly more process water due to the lower percentage of fatty acid-based oil in the autotrophic strain of *Chlorella Vulgaris*, therefore more water is required to grow a greater amount of microalgae.

Table II-4: Equipment Table for Heterotrophic Process

ID#	Equipment Description	# of Units	Total BMC	
C-101 A/B	Fine Grinder	2	\$	440,000
D-101	Leacher	1	\$	34,000
D-102	Surge Drum	1	\$	11,000
E-101-105 A/B	Heat Exchangers	12	\$	180,000
G-101	Gas Compressor and Drive Shaft	1	\$	160,000
H-101 A/B	Vacuum Filter	2	\$	320,000
H-102 A/B	Belt Press	2	\$	380,000
J-101-105 A/B	Conveyors/ Screw Feeders	10	\$	100,000
L-101-113, 201-202 A/B	Pumps	66	\$	680,000
T-101	Water Recycle Tank	1	\$	23,000
R-101 A-C, R-102 A-D	Algae Growth Reactor	7	\$	4,900,000
V-101-107	Evaporator	7	\$	63,000
<b>Total Bare Modular Cost</b>		$C_{TBM}^A \gg$		\$ 7,200,000
<b>Contingency and Fee</b>		$C_{TM}^B$	$C_{TBM}^A * 0.18 =$	\$ 1,300,000
<b>Total Module Cost</b>		$C_{TM}^B \gg$		\$ 8,500,000
<b>Auxiliary Facilities</b>		$C_{AUX}^C$	$C_{TM}^B * 0.30 =$	\$ 2,600,000
<b>Fixed Capital Investment</b>		$FCI^D \gg$		\$ 11,000,000
<b>Working Capital</b>		$C_{WC}^E$	$FCI^D * 0.15 =$	\$ 1,700,000
<b>Chemicals and Catalysts</b>				\$ 340,000
<b>Total Capital Investment</b>		$TCI^F \gg$		\$ 13,000,000

A.  $C_{TBM}$  – Total Bare Modular Cost

B.  $C_{TM}$  – Total Module Cost

C.  $C_{AUX}$  – Auxiliary Facilities Cost

D. FCI – Fixed Capital Investment

E.  $C_{WC}$  – Working Capital

F. TCI – Total Capital Investment

Table II-5: Equipment Table for Autotrophic Process

ID#	Equipment Description	# of Units	Total BMC
C-1001 A/B	Fine Grinder	2	\$ 440,000
D-1001	Leacher	1	\$ 34,000
D-1002	Surge Drum	1	\$ 15,000
E-1001-1005 A/B	Heat Exchangers	12	\$ 280,000
G-1001	Gas Compressor and Drive Shaft	1	\$ 220,000
H-1001 A/B	Vacuum Filter	2	\$ 580,000
H-1002 A/B	Belt Press	2	\$ 380,000
J-101-105 A/B	Conveyors/ Screw Feeders	10	\$ 100,000
L-101-113, 201-202 A/B	Pumps	792	\$ 7,900,800
T-1001 A-C, T-1002	Holding Tank	4	\$ 260,000
R-101 A-C, R- 102 A-D	Algae Growth Reactor	691	\$ 37,000,600
V-101-107	Evaporator	10	\$ 110,000
<b>Total Bare Modular Cost</b>		<b><math>C_{TBM}^A \gg</math></b>	<b>\$47,000,000</b>
<b>Contingency and Fee</b>		<b><math>C_{TM}^B</math></b>	<b><math>C_{TBM}^A * 0.18 =</math></b>
<b>Total Module Cost</b>		<b><math>C_{TM}^B \gg</math></b>	<b>\$ 8,500,000</b>
<b>Auxiliary Facilities</b>		<b><math>C_{AUX}^C</math></b>	<b><math>C_{TM}^B * 0.30 =</math></b>
<b>Fixed Capital Investment</b>		<b><math>FCI^D \gg</math></b>	<b>\$17,000,000</b>
<b>Working Capital</b>		<b><math>C_{WC}^E</math></b>	<b><math>FCI^D * 0.15 =</math></b>
<b>Chemicals and Catalysts</b>			<b>\$ 160,000</b>
<b>Total Capital Investment</b>		<b><math>TCI^F \gg</math></b>	<b>\$84,000,000</b>

A.  $C_{TBM}$  – Total Bare Modular Cost

B.  $C_{TM}$  – Total Module Cost

C.  $C_{AUX}$  – Auxiliary Facilities

D.  $FCI$  – Fixed Capital Investment

E.  $C_{WC}$  – Working Capital

F.  $TCI$  – Total Capital Investment

Table II-6: Operating Costs Summary (\$/yr)

<b>Process</b>	<b>Year</b>	<b>Raw Materials</b>	<b>Chemicals &amp; Catalysts</b>	<b>Operating Labor</b>	<b>Maintenance</b>	<b>Utilities</b>	<b>Royalties &amp; Patent Fees</b>	<b>Other Expenses</b>	<b>Yearly Total</b>
Heterotrophic	1-20	880,000	180,000	1,600,000	660,000	370,000	-	28	3,700,000
Autotrophic	1-20	7,400,000	2,300,000	14,000,000	4,400,000	210,000,000	-	60	240,000,000

Table II-7: Nutrient Cost Chart and Media Requirements<sup>23</sup>

Component	Cost (\$/kg)	Heterotrophic Basal Media		Bolds Basal Media	
		kg/yr	Cost (\$/yr)	kg/yr	Cost (\$/yr)
Sodium Nitrate <sup>24</sup>	0.10			590,000	290,000
Calcium Chloride <sup>25</sup>	0.024	110	10.00	59,000	7,100
Magnesium Sulfate <sup>26</sup>	0.13	1,400	860.00	180,000	110,000
Dipotassium Hydrogen Phosphate <sup>27</sup>	0.41	1,400	2,700.00	180,000	350,000
Potassium Dihydrogen Phosphate <sup>28</sup>	0.41	3,200	6,400.00	420,000	840,000
Sodium Chloride <sup>29</sup>	0.045	110	20.00	59,000	13,000
Trace Element Solution** <sup>30</sup>	0.81	4,500	18,000.00	43,000	170,000
Sucrose <sup>21</sup>	-	3,000,000	-	-	\$-
Yeast Extract <sup>31</sup>	1.60	18,000	150,000.00		
EDTA <sup>30</sup>	16			24,000	1,900,000
Acidified Iron Stock Solution <sup>32</sup>	0.000054			43,000	\$12
Boric Acid <sup>33</sup>	0.31			43,000	65,000
Distilled Water	-	4,500,000	-	24,000,000	\$-
<b>Total</b>		<b>7,700,000</b>	<b>180,000.00</b>	<b>56,000,000</b>	<b>3,700,000</b>

\*\*Trace Element Solution priced as 5% EDTA

The chemicals required for the heterotrophic process are the nutrients required for the Heterotrophic Basal Media (HBM) while those required for the autotrophic process are the nutrients required for the Bolds Basal Media (BBM). The nutrient requirements and costs are reported in Table 7. The costs associated with the media were priced based on bulk prices commercially available for each component. The bulk price of EDTA was obtained from a vendor<sup>24</sup>. The HBM was estimated to cost a total of \$180,000 per year. The BBM was estimated to cost a total of \$2.3 million per year. The difference in the cost of chemicals for the two processes is due to the larger quantity of chemicals required to generate the BBM per liter in comparison to the quantity of chemical to generate the HBM per liter.

The heterotrophic process design requires an estimated five operators per shift with an additional board operator yielding a total of 21 operators across 4.5 shifts to obtain a 95% operating factor. The autotrophic process design requires 36 operators per shift with an additional board operator, yielding a total of 166 operators across 4.5 shifts. The labor estimation requirement was determined by utilizing the method found in Ulrich<sup>13</sup>. The average hourly wage for a plant operator in Texas of \$25.86<sup>25</sup> was used. Due to the number of operators needed per day, a supervisor was also estimated to be required. The supervisory labor cost was estimated to be 15% of the operating labor costs.<sup>10</sup> The total yearly labor cost for the heterotrophic design was estimated at approximately \$1.6 million while the costs for the autotrophic design case were estimated to be approximately \$40 million. The estimate for the cost of labor is based on the number of pieces of minor and major equipment each process contains. The autotrophic process design has a higher

quantity of equipment due to the large number of photobioreactors required, thus generating a much higher cost of labor in comparison to the heterotrophic process.

The maintenance cost for the heterotrophic and autotrophic process designs were estimated by utilizing the rule of thumb that the cost of maintenance is 6% of the fixed capital investment<sup>13</sup>. The cost of maintenance is reported in Table 6. The yearly cost for maintenance for the heterotrophic process design is approximately \$660,000 while the yearly cost for maintenance for the autotrophic process design is approximately \$21 million. The estimate for the cost of maintenance is based on the cost of the fixed capital investment for each process. The autotrophic process design has a higher fixed capital investment due to the large number of photobioreactors required in area 01, thus generating a much higher cost of maintenance in comparison to the heterotrophic process.

The required utilities for the heterotrophic process design are electricity, low pressure steam, process water, cooling water, low temperature refrigerated water, and methanol, whereas the required utilities for the autotrophic process design are electricity, low pressure steam, medium pressure steam, cooling water, heating water, moderately low temperature refrigerated water, and methanol. The annual requirement for each utility is reported in Table 2. The price of electricity was found using trend price data. The costs for low pressure steam, medium pressure steam, heating water, moderately low temperature refrigerated water, process water, and cooling water were estimated using commonly accepted utility prices<sup>20</sup>. The price of methanol was determined to be \$0.23 per pound<sup>26</sup>, with an estimated 5% annual make-up.

The difference in the cost of utilities for the two processes is due to the difference in water and steam consumption. The autotrophic process requires significantly more



process water due to the heating and cooling of the photobioreactors to ensure the microalgae is grown at a consistent temperature year-round. Additionally, low pressure steam is utilized to sterilize the tank reactors and photobioreactors after each use. A greater amount of low-pressure steam is required for the autotrophic process due to the increased quantity of reactors required.

### *3.4 Revenues*

The revenue earned by the heterotrophic and autotrophic process designs are generated by the sale of the extracted lipids to be utilized in the production of biodiesel and high value chemicals and from sales of the lipid-lean biomass. The value for the lipid was based on a high value, unconverted bio-oil<sup>27</sup>. The lipid-lean biomass is sold as high protein animal feed. Table 8 reports the analysis of the revenues from the product and by-product. The total yearly revenues for the heterotrophic and autotrophic processes, respectively, are approximately \$1.3 million and \$3.1 million. No tax credits associated with “green” products production were added to these revenues. In order to drive each process towards economic viability, the total revenue for each process needs to increase. The current economic analysis indicates that each process generates less revenue than is required on an annual basis for operating costs. The total revenue could be increased if either the fatty acid-based oil was sold at a higher rate, or if a higher value co-product was also produced.

Table II-8: Revenue Projection for the Heterotrophic and Autotrophic Processes

Products	\$ /kg	Heterotrophic		Autotrophic	
		Amount (kg/yr)	Revenue (\$/yr)	Amount (kg/yr)	Revenue (\$/yr)
Lipids	\$ 0.40	500,000	\$ 970,000	500,000	\$ 970,000
Biomass	\$ 0.059	1,000,000	\$ 300,000	2,800,000	\$ 2,100,000
		<b>Total</b>	<b>\$1,300,000</b>		<b>\$ 3,100,000</b>

Note: Numbers may not sum to total due to rounding

### 3.5 Overall Profitability

The cash flow sheets for the heterotrophic and autotrophic process designs are reported in Tables 9 and 10, respectively and indicate the overall profitability. The fixed capital investment required for the project was spread out over 15 months as specified by the preliminary schedule. Over the 20-year lifetime of the heterotrophic project, it has an NPV@20% of negative \$20 million  $\pm$  40% while the autotrophic project has a negative NPV@20% of \$850 million  $\pm$  40%. Based on this economic assessment, the project is expected to be unprofitable. If a tax credit of \$11.0/liter is added to the revenues, the heterotrophic process will rise to a breakeven point.

Adjusting the revenue price of the primary product, the breakeven point for the heterotrophic process corresponds to an oil products price of \$14/kg (\$3.30/gal) while the comparable sales price for the autotrophic process is \$240/kg (\$126/gal). In 2014, a process design with economics produced by the National Renewable Energy Laboratory (NREL) indicated that the breakeven point for a microalgae oil was \$4.35/gallon gasoline equivalent (GGE). The goal is to advance microalgae oil extraction to a cost of \$3/GGE<sup>28</sup>. The designed heterotrophic process the oil price was determined to be \$3.89/GGE. These results suggest that if one or more of the key steps in the process can be made more cost

efficient, heterotrophic microalgae production may become a competitive source for renewable biofuels/chemicals oil feedstock.

Table II-9: Economic Cash Flow Sheet for the Heterotrophic Process (\$ millions)

Job Title: Oil Extraction from Heterotrophic Microalgae

Location: Texas

Basis Date: Oct 2016

Year	Revenues	Operating Cost	Gross Profit	Depreciation	Taxable Profit	Income Tax	Nontaxable Charges	Net Profit	Present Value @20%
-1							(2.2)	(2.2)	(2.6)
0							(11)	(11)	(11)
1	1.3	(3.7)	(2.4)	1.3	3.7	1.3		(1.1)	(0.92)
2	1.3	(3.7)	(2.4)	1.1	3.5	1.2		(1.2)	(0.81)
3	1.3	(3.7)	(2.4)	1.0	3.4	1.2		(1.2)	(0.70)
4	1.3	(3.7)	(2.4)	0.89	3.3	1.2		(1.2)	(0.60)
5	1.3	(3.7)	(2.4)	0.78	3.2	1.1		(1.3)	(0.52)
6	1.3	(3.7)	(2.4)	0.69	3.1	1.1		(1.3)	(0.44)
7	1.3	(3.7)	(2.4)	0.61	3.0	1.1		(1.3)	(0.38)
8	1.3	(3.7)	(2.4)	0.54	2.9	1.0		(1.4)	(0.32)
9	1.3	(3.7)	(2.4)	0.48	2.9	1.0		(1.4)	(0.27)
10	1.3	(3.7)	(2.4)	0.45	2.8	1.0		(1.4)	(0.23)
11	1.3	(3.7)	(2.4)	0.45	2.8	1.0		(1.4)	(0.19)
12	1.3	(3.7)	(2.4)	0.45	2.8	1.0		(1.4)	(0.16)
13	1.3	(3.7)	(2.4)	0.45	2.8	1.0		(1.4)	(0.13)
14	1.3	(3.7)	(2.4)	0.45	2.8	1.0		(1.4)	(0.11)
15	1.3	(3.7)	(2.4)	0.45	2.8	1.0		(1.4)	(0.090)
16	1.3	(3.7)	(2.4)	0.45	2.8	1.0		(1.4)	(0.080)
17	1.3	(3.7)	(2.4)	0.45	2.8	1.0		(1.4)	(0.060)
18	1.3	(3.7)	(2.4)	-	2.4	0.84		(1.6)	(0.060)
19	1.3	(3.7)	(2.4)	-	2.4	0.84		(1.6)	(0.050)
20	1.3	(3.7)	(2.4)	-	2.4	0.84	1.7	0.14	0.0037
NPV @20%=									(20)

Note: Numbers in parentheses represent negative values

Table II-10: Economic Cash Flow Sheet for the Autotrophic Process (\$ millions)

Job Title: Oil Extraction from Autotrophic Microalgae

Location: Texas

Basis Date: Oct 2016

Year	Revenues	Operating Cost	Gross Profit	Depreciation	Taxable Profit	Income Tax	Nontaxable Charges	Net Profit	Present Value @20%
-3							(15)	(15)	(30)
-2							(19)	(19)	(30)
-1							(19)	(19)	(23)
0							(30)	(30)	(30)
1	3.1	(240)	(240)	8.6	(250)	(90)		(150)	(130)
2	3.1	(240)	(240)	7.6	(240)	(90)		(150)	(110)
3	3.1	(240)	(240)	6.7	(240)	(90)		(150)	(88)
4	3.1	(240)	(240)	5.9	(240)	(80)		(150)	(73)
5	3.1	(240)	(240)	5.2	(240)	(80)		(150)	(61)
6	3.1	(240)	(240)	4.6	(240)	(80)		(150)	(51)
7	3.1	(240)	(240)	4.1	(240)	(80)		(150)	(43)
8	3.1	(240)	(240)	3.6	(240)	(80)		(150)	(36)
9	3.1	(240)	(240)	3.2	(240)	(80)		(150)	(30)
10	3.1	(240)	(240)	3.0	(240)	(80)		(150)	(25)
11	3.1	(240)	(240)	3.0	(240)	(84)		(150)	(21)
12	3.1	(240)	(240)	3.0	(240)	(84)		(150)	(17)
13	3.1	(240)	(240)	3.0	(240)	(84)		(150)	(14)
14	3.1	(240)	(240)	3.0	(240)	(84)		(150)	(12)
15	3.1	(240)	(240)	3.0	(240)	(84)		(150)	(10)
16	3.1	(240)	(240)	3.0	(240)	(84)		(150)	(8.3)
17	3.1	(240)	(240)	3.0	(240)	(84)		(150)	(6.9)
18	3.1	(240)	(240)	-	(240)	(83)		(150)	(5.8)
19	3.1	(240)	(240)	-	(240)	(83)		(150)	(4.8)
20	3.1	(240)	(240)	-	(240)	(83)	11	(140)	(3.7)
								NPV@=	(850)

Note: Numbers in parentheses represent negative values

#### 4. Conclusion

The objective of this scoping study was to determine if a process for the growth and extraction of lipids from the heterotrophic microalgae strain of *Chlorella Vulgaris* would be more economically attractive than a process based on the autotrophic version of the same microalgae. A process design was developed for the growth and extraction of lipids from the heterotrophic strain of *Chlorella Vulgaris* and the autotrophic strain of *Chlorella Vulgaris*. Using the heterotrophic strain was clearly more cost effective than the autotrophic strain, although currently, neither the heterotrophic nor autotrophic process designs are economically feasible. However, the heterotrophic-based process is close to the breakeven point and suggests that this strategy has the potential, with additional advances, of providing a commercially viable industrial microalgae oil generation and extraction facility.

Several recommendations to improve the economic feasibility of this technology can be concluded from the design. The two areas which appear to have the most room for improvement are the growth phase and the fatty acid solvent extraction phase. During the heterotrophic microalgae growth phase, the media requires a large quantity of chemicals and an organic carbon for production. If an alternative growth media which already contained some of the nutrients was identified and/or if an alternative organic carbon source, such as a wastewater stream routed from another industrial process, were utilized, the cost of growing the microalgae would decrease greatly. Additionally, the cell density of the microalgae during in the growth media is very low, resulting in a large water requirement. The large water requirement causes the dewatering of the microalgae to be

energy intensive. If a method of increasing cell density during growth was developed, the cost of the growth phase would decrease.

The fatty acid solvent extraction requires a low ratio of microalgae to solvent to efficiently extract the oils. The large quantity of solvent is cost prohibitive to use and recover from the low quantity of oils extracted. The total oils in the methanol after extraction is approximately 3.9 wt%. This low concentration results in the selection of a multi-effect evaporator to most efficiently separate the two miscible liquids. If a more efficient solvent extraction step were developed, the cost of the solvent recovery would decrease, and the separation step would be simplified, pushing the economics of the process towards profitability. Further, adding a less energy intensive preconcentration step for the oils-in-methanol solution, such as a pervaporation membrane may also further reduce costs.

An evaluation of the innovation of utilizing a strain of non-light dependent heterotrophic microalgae has shown that this alternative application of microalgae is a plausible source of fatty acid-based oil and that this process is closer to economic viability than autotrophic-based facilities. By continuing to develop and focus current research on the described hurdles, the utilization of a heterotrophic microalgae fatty acid-based oil extraction to be converted into renewable replacements for many petroleum derived fuels and chemicals has the potential to become a viable alternative.

### *5. Acknowledgments*

The authors would like to thank the following for their contributions to this work: Edward Kolodka, Yun Ji, Ian Foerster, and Maram Al-Sayaghi. Funding for the experimental work was provided by the U.S. National Science Foundation International Research Experiences for Students program. Any opinions, findings, and conclusions or recommendations expressed in this material are those of the author(s) and do not necessarily reflect the views of the NSF.



CHAPTER III. COMPARATIVE STUDY OF THE GROWTH OF TWO SUBSPECIES OF CHLORELLA VULGARIS, AUTOTROPHIC AND HETEROTROPHIC MICROALGAE, FOR OPTIMAL LIPID CONTENT

## *Abstract*

The interest in microalgae as a plausible alternative to crop oils as a raw material in the form of triglycerides and free fatty acids (FA oils) for renewable fuels and chemicals is increasing. Traditional autotrophic microalgae cultivation at the industrial scale is challenging because either numerous photo bioreactors or large open ponds are required to disperse photons throughout the feedstock for efficient photosynthesis. This presents a challenge because of the considerable economic investment to procure and manage the large quantity of reactors, water, and nutrients necessary for commercial scale FA oil production.

Recently, researchers have begun transforming autotrophic microalgae to heterotrophic microalgae, negating the light dependence of the studied strains. The transition to heterotrophic halts the photosynthesis process, but requires an organic carbon source to provide energy, as the heterotrophic strain of microalgae is unable to assimilate carbon dioxide as an energy source via photosynthesis<sup>4</sup>. The transition from autotrophic to heterotrophic has been shown to increase the FA oil content of the microalgae by replacing the chlorophyll cells produced during photosynthesis with additional Lipids<sup>5,6</sup>.

In the present study, a comparison of the autotrophic strain of *Chlorella Vulgaris* to its adapted heterotrophic analog performed. This work provides thermal carbon analysis, as well as ultimate analysis, to showcase the differences between the autotrophic and heterotrophic strain of *Chlorella Vulgaris* grown inhouse at the University of North Dakota, and the autotrophic strain of *Chlorella Vulgaris* obtained from the University of Leeds. Both analyses indicate an increased lipids content in the heterotrophic microalgae when directly compared to autotrophic microalgae.

### *1. Introduction:*

The interest in microalgae as a plausible alternative to crop oils as a raw material in the form of triglycerides and free fatty acids (FA oils) for renewable fuels and chemicals is increasing. By utilizing microalgae as the feedstock, the land area required to produce lipids in the form of FA oils is significantly smaller than oilseed crops. Microalgae has a two week growing and cultivation cycle, and can reproduce from a cell density of 0.040 g/L to a maximum cell density of 20 g/L during that cycle<sup>16</sup>. The shorter growing cycle of microalgae maximizes the number of harvesting cycles per year compared to harvesting once or twice a year due to the lengthy growing season when using oilseed crops<sup>10</sup>. In the United States, 2.3 billion kilograms per year of soybeans are used for the extraction of FA oils for fuels. The necessary soybeans are grown utilizing 8.1 billion square meters of farmland<sup>29</sup>. However, if the raw material source for the FA oils was converted entirely to microalgae the annual land mass requirement would be 810 million square meters annually<sup>30</sup>.

Traditionally, the microalgae are grown in an autotrophic environment where the microalgae require an inorganic carbon source, such as carbon dioxide, combined with a light source to create energy via photosynthesis. Autotrophic microalgae do not require an oxygen source for cellular respiration as oxygen is produced as a by-product in the algae's photosynthesis reaction and therefore does not need to be supplied for growth<sup>4</sup>. Supplementary chemicals supplied to the system as growth media and catalysts are required for optimum growth and development of the microalgae strains.

Autotrophic microalgae cultivation at the industrial scale is challenging because either numerous photo bioreactors or large open ponds are required to disperse photons throughout the feedstock for efficient photosynthesis. The best photo bioreactors currently available are small-diameter, clear plug flow reactors (PFRs) or polymer-bag batch reactors which present a challenge because of the considerable economic investment to procure the large quantity necessary for commercial scale FA oil production.

Previous studies have demonstrated the growth of microalgae in open ponds for world scale production. However, the cell density during growth was substantially decreased compared to photo bioreactors. Open ponds present the challenges of dependency on the natural elements which contain a high level of uncertainty such as cloudy days and precipitation, as well as contamination which may occur from a non-enclosed system. These challenges can be mitigated by enclosing the open ponds, although this adds additional capital expense, and these efforts would not mitigate the risk of non-sunny days<sup>31</sup>.

If the strain of microalgae used was non-light dependent it could negate the requirement for massive numbers of clear photo bioreactors or open ponds at the industrial scale. Recently, researchers have begun transforming autotrophic microalgae to heterotrophic conditions, negating the light dependence of the studied strains. The transition to heterotrophic halts the photosynthesis process, and requires an organic carbon source to provide energy, as the heterotrophic strain of microalgae is unable to assimilate carbon dioxide as an energy source via photosynthesis<sup>4</sup>. Heterotrophic strains also require an outside source of oxygen for cellular respiration. However, because heterotrophic strains can be grown in enclosed tank reactors, the required capital investment, land mass,

and maintenance will all be substantially reduced due to the drastic difference in the number of growth reactors required compared to the autotrophic strains which increases the feasibility of scale-up<sup>11</sup>.

The transition from autotrophic to heterotrophic has been also been shown to increase the FA oil content of the microalgae by replacing the chlorophyll cells produced during photosynthesis with additional Lipids<sup>5,6</sup>.

The first goal of the present study was to grow, transition, and compare the autotrophic strain of *Chlorella Vulgaris* to the heterotrophic strain of *Chlorella Vulgaris*. The second goal was to study various organic carbon concentrations in the Heterotrophic Basal Media (HBM) utilized for growth of the heterotrophic microalgae and identify the optimum concentration range of organic carbon in the growth media to produce the largest quantity of Lipids.

## *2. Materials and Methods:*

### *2.1 Materials and Reagents*

For the present study, a single strain of autotrophic *Chlorella Vulgaris* was purchased from Carolina Biological (Item # 152075). The sample was inoculated into a Bolds Basal Media (BBM) growth solution, defined in Appendix J.1. The microalgae were grown for 2 weeks before additional BBM growth media was added.

The heterotrophic *Chlorella Vulgaris* microalgae was generated by transplanting a portion of the generated autotrophic *Chlorella Vulgaris* into a PVC (nearly dark) tubular reactor with Heterotrophic Basal Media (HBM), defined in Appendix J.2, to begin the transition from autotrophic to heterotrophic. The microalgae were grown for 2 weeks before additional HBM growth media was added. Eight PVC reactors were inoculated with

450 mL of autotrophic *Chlorella Vulgaris* and 1500 mL of HBM, with four different concentrations of sucrose (used as the carbon source). A four sets of two reactors were inoculated with heterotrophic microalgae and one of the four concentrations of sucrose, either 20, 40, 60, or 80 g/L.

A second strain of autotrophic *Chlorella Vulgaris* microalgae was obtained from a culture grown at the University of Leeds, Leeds, UK from the original 80-120 mesh, freeze-dried strain purchased from Qingdao Sunrise Trading Co., Ltd., Qingdao, China.

The following chemicals were utilized to produce the BBM and HBM growth solutions. Sodium Nitrate was purchased from Fisher Scientific, product number 7631-99-4. Calcium Chloride was purchased from Fisher Scientific, product number C70-500. Magnesium Sulfate Heptahydrate was purchased from Fisher Scientific, product number 10034-99-8. Dipotassium Hydrogen Phosphate was purchased from Sigma Aldrich, product number P3786-100G. Potassium Dihydrogen Phosphate was purchased from Fisher Scientific, product number 7778-77-0. Sodium Chloride was purchased from Fisher Scientific, product number 7647-14-5. Copper Sulfate Pentahydrate product number 60-004-59, molybdenum trioxide product number ICN15254880, zinc sulfate heptahydrate product AC205982500, manganese chloride tetrahydrate product M87-100, cobalt nitrate hexahydrate product AC213091000 were all purchased from Fisher Scientific to generate Trace Element Solution. EDTA was purchased from Sigma Aldrich, product number ED2SSS-50G. Acidified Iron Stock Solution was purchased from Fisher Scientific, product number 7782-63-0. Boric Acid was purchased from Fisher Scientific, product number A74-500. 2.3 kg bags of American Crystal retail brand sugar was obtained locally

to be used as the organic carbon source. Yeast Extract was purchased from Fisher Scientific, product number 8013-01-2.

## *2.2 Experimental Setup*

An Electrolab Biotech Ltd. Photobioreactor (Northway Trading Estate, Tewkesbury UK), with a model 320 Series Light Shroud for 10L 200 vessel was utilized for the growth of the autotrophic *Chlorella Vulgaris* at the larger scale. A 10L scale allowed for an adequate quantity of microalgae to be harvested and analyzed. Additionally, the bioreactor provided aerating and stirring attachments that were utilized to facilitate growth.

A Masterforce Ultra-Quiet 6.8 liter 860 kPa Portable Electric Trim Air Compressor (Alton Industries, Batavia, IL USA) was utilized as an air supply for the heterotrophic growth tank reactors. An air compressor was required to supply adequate air flow to the eight tank reactors, where the air was dispersed through a layer of bubbling stones for aeration and mixing with the microalgae slurry.

A Barnstead Thermolyne Corporation 21100 Tube Furnace (Thermo Fisher Scientific, Waltham, MA USA) was utilized to sterilize the air supply from the Masterforce Air Compressor before entering the heterotrophic tank reactors. This was necessary as the air supply for the tank reactors was air from the surrounding room.

Two SPEARS 15 cm PVC Pipe Caps (SKU: 447-060; SPEARS Manufacturing, Sylmar, CA USA) and 46 cm lengths of 15 cm diameter Solid Core PVC Plain End Schedule 40 Pipe (SKU: 6899725; Charlotte Pipe and Foundry Company, Charlotte, NC USA) were utilized to construct each individual heterotrophic tank reactor. The PVC

offered a near dark design to eliminate the ability of most light to penetrate the reactors. The amount penetration was insufficient to sustain an autotrophic culture of the microalgae.

### *2.3 Experimental Methods*

The *Chlorella Vulgaris* autotrophic microalgae was grown in three 500 mL Erlenmeyer flasks, as well as the Electrolab Biotech Ltd. 10 L photo bioreactor. The Erlenmeyer flasks were utilized for analyzing growth rate, while the photo bioreactor was utilized for larger scale production of microalgae. Each Erlenmeyer flask was capped with a 2-hole stopper and was filled with a small portion of the inoculated algae suspended in Bolds Basal Media. A second Erlenmeyer flask containing deionized (DI) water and capped with a 2-hole stopper was utilized in parallel to each growing flask. One hole of the microalgae growing flask contained a small glass tube which extended into the microalgae solution and approximately 2.5 cm above the stopper. The portion above the stopper was topped with clear 0.64 cm outer diameter vinyl tubing connecting the glass tube to another glass tube inserted the DI water flask but kept above the water level.

A second glass tube was inserted into the 2-hole stopper of the DI flask and kept below the water level and extended to approximately 2.5 cm above the stopper. Clear 0.64 cm outer diameter vinyl tubing connected the extended glass tube of the DI water flask to a Petco Aquarium Air pump (AC-9904) to aerate with moist air and create movement in the microalgae solution. The excess air was routed out of the reactors and vented to a fume hood. GT-Lite 32W Equivalent Linear Fluorescent Grow Lights were utilized for the light source to stimulate the process of photosynthesis in the autotrophic microalgae grown in the Erlenmeyer flasks.



The photobioreactor was filled with a small portion of the inoculated algae suspended in Bold's Basal Media. An Erlenmeyer flask containing deionized (DI) water and capped with a 2-hole stopper was utilized in parallel to the photobioreactor. The photobioreactor contained an aerator attachment which was connected to the Erlenmeyer flask filled with DI water by clear 0.64 cm outer diameter vinyl tubing in a similar manner as the Erlenmeyer flask used for microalgae growth. The excess air was routed out of the reactors and vented to a fume hood. Voltix Full Spectrum A19 LED Grow Lightbulbs were utilized for the light source to stimulate the process of photosynthesis in the autotrophic microalgae grown in the 10L Photobioreactor. A stirring attachment and motor for the photo bioreactor were used to provide additional movement in the microalgae solution.

The *Chlorella Vulgaris* heterotrophic microalgae was grown in 10 15cm diameter by 46 cm tall polyvinyl chloride (PVC) reactors. The PVC reactors were utilized for analyzing growth rate and larger scale production of microalgae. The bottom of each reactor was closed with a 15 cm PVC cap and sealed. The top of each reactor was closed with a 15 cm PVC cap and left unsealed. Two G.A. Murdock, Inc. JG Speedfit fittings were built into the caps for each reactor to allow air inlet and outlet ports. The reactor inlet was equipped with a 0.64 cm JG Speedfit Bulkhead Union-Grey fitting on the outside of the cap and a 0.95 cm JG Stem x 0.64 cm Hose Barb Grey fitting on the inside of the cap. The Bulkhead fitting was connected to 0.64 cm MUR-LOK LLDPE Tubing to the air inlet. The hose barb fitting was connected to 0.64 cm low density polyethylene tubing to an Imagitarium Bubbling Column of 2.5 cm Airstone (Marineland Spectrum Brands Pet LLC, Blacksburg, VA USA) to aerate the microalgae. The outlet of each tank reactor used a 0.64

cm JG Speedfit x 0.64 cm Male NPTF-Grey connected to 0.64 cm MUR-LOK LLDPE Tubing to route excess air out of the reactors and vent to a fume hood. The outlet stream from the Masterforce Air Compressor was routed through the Barnstead Thermolyne Corporation Tube Furnace to sterilize the air before being split into 10 streams to supply the microalgae solution with the necessary oxygen for growth and development. The air to each tank reactor was controlled by a 0.64 cm JG Speedfit Shut Off Valve. From the Shut Off Valve, the sterilized air was routed to the inlet of each tank reactor.

To analyze the growth rate of the heterotrophic microalgae, eight PVC reactors were inoculated with 450 mL of autotrophic *Chlorella Vulgaris* and 1500 mL of HBM, with four different concentrations of sucrose (used as the carbon source). A four sets of two reactors were inoculated with heterotrophic microalgae and one of the four concentrations of sucrose, either 20, 40, 60, or 80 g/L. Microalgae in each reactor was allowed to grow for a 22-day period without the addition of any growth media. Two 1.0 mL samples were collected from each of the reactors on days 1, 4, 7, 10, 13, 16, 19, and 22. Each sample vial was weighed before and after sampling to determine the exact quantity sampled. One of the samples from each flask was capped to be analyzed via high performance liquid chromatography. The second sample was placed in a drying oven at 50°C to evaporate the liquid so that the mass of the total solids in each sample could be quantified.

#### *2.4 Analytical Methods*

A Flash 2000 CHNS-O, with Flash EA 1112 FPD was utilized to performed carbon, hydrogen, nitrogen, and sulfur Analyses (CHNS). These analyses were performed by allotting a small amount of combustible solid or liquid sample into a tin capsule to perform

elemental (ultimate) analysis. An oxidation/reduction reaction operating at 900-1000°C occurs by introducing oxygen into the system to facilitate complete combustion. The initial reactions cause an exothermic reaction between the oxygen and the tin capsule, causing the temperature to increase to 1800 °C which gasifies all components of the sample into elemental gases. Carbon dioxide is generated from the carbon, water is generated from the hydrogen, N<sub>2</sub> or NO<sub>x</sub> are generated from the nitrogen, and sulfur dioxide is generated from the sulfur. These gases are separated in a chromatographic column and analyzed by a thermal conductivity detector.

Thermal carbon analysis (TCA) was completed utilizing a thermal optical analyzer from Sunset Laboratory Inc. (Portland, OR). Methanol was used to dissolve each of the feedstock samples for quantification. 10 µL of each sample was loaded onto a Pall Flex 2500QAT-UP tissue quartz filter (Pall Corp. East Hills, NY). The sample was dried at 50°C for 7 minutes to evaporate the methanol before analysis<sup>32</sup>. A sucrose (40 µg of loaded carbon) run was used as a daily external calibration. All samples were analyzed in triplicate.

High performance liquid chromatography (HPLC) was utilized to observe the changes in the autotrophic and heterotrophic *Chlorella Vulgaris* microalgae during the growth cycle. An Agilent 1200 series HPLC coupled to an Agilent Refractive Index Detector Model G1362A (Agilent, Santa Clara, CA USA) was used to analyze the microalgae solution with an Agilent Hi-Plex H Organic Acid Column, catalog #PL1170-68530 (Stockport, UK) and a 5 millimolar sulfuric acid mobile phase (EMD Millipore Corporation H<sub>2</sub>SO<sub>4</sub> 98% for analysis EMSURE, Chicago, USA).

Each sample analyzed by HPLC was collected in 1.0 mL volumes at various time increments during the growth cycle of the microalgae. Each sample was filtered using a 0.20-micron nylon membrane Acrodisc syringe filter (Pall Corporation, Catalog #PN4540) into a 2 mL Thermo Scientific HPLC vial (Fisher Sci, Catalog #03-375-3R).

### *3. Results and Discussion*

The two goals of the present study were: 1) to grow, transition, and compare the autotrophic strain of *Chlorella Vulgaris* to the heterotrophic strain of *Chlorella Vulgaris* and 2) to study various organic carbon concentrations in the Heterotrophic Basal Media (HBM) utilized for growth of the heterotrophic microalgae and identify the optimum concentration range of organic carbon in the growth media to produce the largest quantity of lipids. To achieve these goals, several different analytical techniques were employed. The first goal of growing, transitioning, and comparing the autotrophic strain of *Chlorella Vulgaris* to the heterotrophic strain of *Chlorella Vulgaris* was met by performing thermal carbon analysis and ultimate analysis of each strain. For the second goal of the study, the organic carbon concentration in the HBM was varied to identify the optimum concentration range of organic carbon in the growth media to produce the largest quantity of lipids. These were assessed by performing HPLC of various samples during the growth cycle.

#### *3.1. Thermal Carbon Analysis and Ultimate Analysis*

The first method of analysis for comparison for autotrophic and heterotrophic microalgae was TCA. TCA evaluates the total carbon in a sample across several temperature fractions<sup>32</sup>. Figure III-1 indicates the total pyrolyzed carbon at each temperature fraction for each of the three feedstocks. Each temperature fraction is represented as the fraction of the initial microalgae that elutes at that temperature. This

was completed by dividing the total carbon evolves in each fraction by the total amount spiked.

The 200°C fraction is assumed to represent the carbon in the carbohydrates in each feedstock while the 300°C and 400°C fractions are assumed to represent the carbon in the lipids in each feedstock. All temperature fractions above 400°C are assumed to represent the proteins in each feedstock. The goal of this analytical method was to study the 300°C and 400°C fractions of each feedstock and compare to determine if the heterotrophic microalgae had a higher lipids content than the original autotrophic strain<sup>56</sup>.

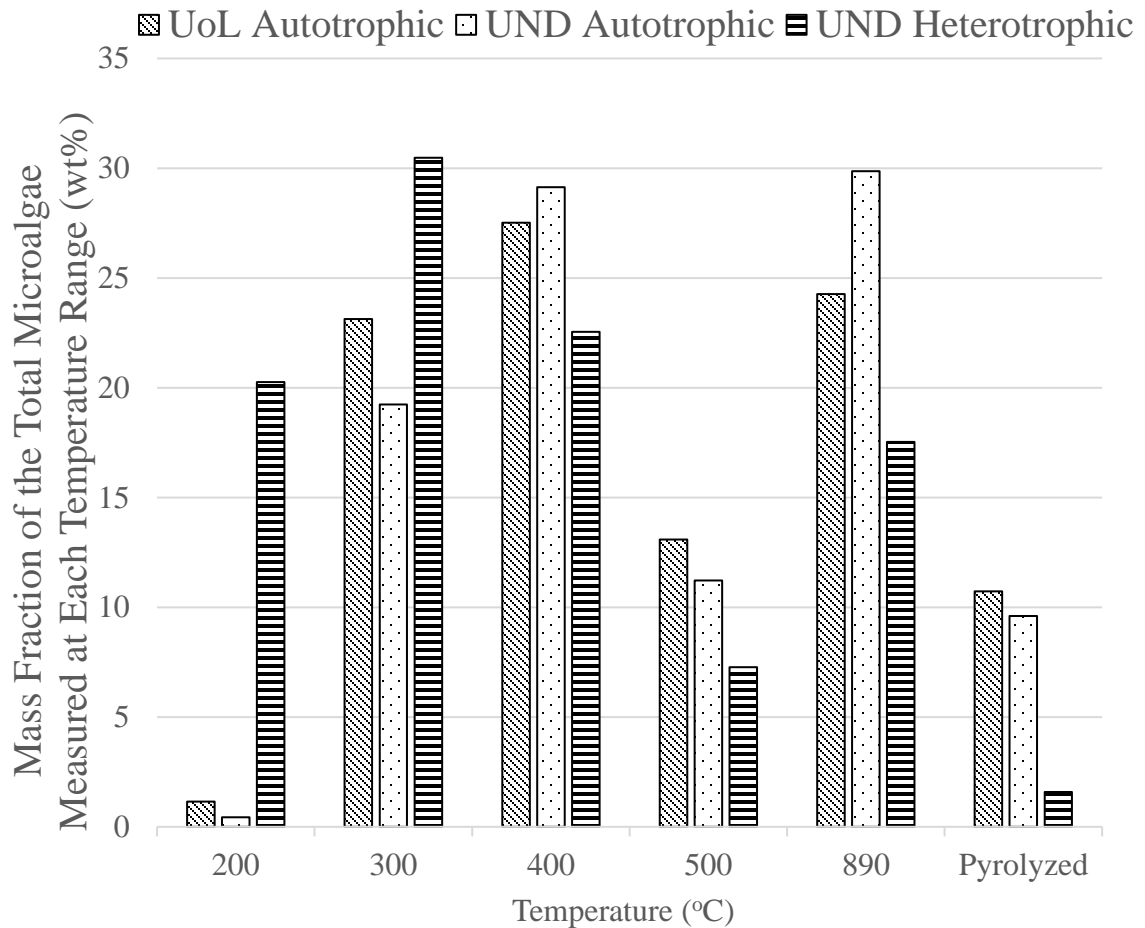

*Figure III-1:* Thermal carbon analysis results for the total eluded carbon at each temperature fraction for each feedstock.

The heterotrophic microalgae yielded 53% of the total carbon in the 300°C and 400°C fractions while the in-house autotrophic microalgae yielded 48% carbon in the 300°C and 400°C fractions. The autotrophic microalgae obtained from the University of Leeds yielded 51% carbon in the 300°C and 400°C fractions. The heterotrophic feedstock yielded the highest percentage of carbon in the 300°C and 400°C fractions by 5% when compared to the in-house autotrophic microalgae. These values fall within literature values for the *Chlorella Vulgaris* strain of microalgae has been proven to have a lipid content between 15-35 wt%<sup>2</sup>.

The second method of analysis for comparison of autotrophic and heterotrophic microalgae was ultimate analysis. This method identified the elemental components to each feedstock, as well as its energy value, as shown in Table 1. The heterotrophic strain of microalgae yielded the highest caloric value of the analyzed samples. Beyond the difference in caloric value, the elemental analysis indicates only very minor differences between the feedstocks.

*Table III-1:* Ultimate Analysis of the three different microalgae feedstocks (mean values ±standard deviation).

<b>Sample</b>	<b>N (wt%)</b>	<b>C (wt%)</b>	<b>H (wt%)</b>	<b>S (wt%)</b>	<b>Gross Caloric Value (kCal kg<sup>-1</sup>)</b>	<b>Net Caloric Value (kCal kg<sup>-1</sup>)</b>
UND Autotrophic	4.9 ± 0.1	48 ± 0.8	8.6 ± 0.3	ND <sup>1</sup>	6500 ± 100	6100 ± 100
UND Heterotrophic	6.0 ± 0.05	50 ± 1.0	9.7 ± 0.2	ND	7000 ± 200	6500 ± 100
UoL Autotrophic	7.6 ± 0.05	46 ± 0.1	8.2 ± 0.2	ND	6200 ± 50	5800 ± 40

<sup>1</sup> ND = below detection limit

The results obtained from the Thermal Carbon Analysis and Ultimate Analysis support the literature that indicates that with conversion to heterotrophic microalgae growth from autotrophic growth, the lipid concentration in the cell increases and replaces the

chlorophyll. When the lipids replace the chlorophyll, it yields a higher concentration of total carbon in the 300°C and 400°C fractions. Further, lipids have a higher energy value than chlorophyll and thus the caloric value is higher for heterotrophic microalgae<sup>5,6</sup>.

### 3.2. HPLC Analysis

The HPLC analysis method was used to assess the effectiveness of various concentrations of organic carbon in the HBM growth solution for lipids production. To compare the growth and production of the lipids in heterotrophic *Chlorella Vulgaris* microalgae, samples from each reactor on incremental days throughout the growth cycle were analyzed. Four different concentrations of organic carbon were studied in the Heterotrophic Basil Media to assess the effect of varying composition on growth.

All the components of each growth media and the final mixture of the growth media were analyzed individually by HPLC to determine the retention times of the concentrated components individually and in the growth media mixture. Each chemical of the growth media was analyzed individually at a higher concentration than present in the final growth media solution, as the HBM dilutes each individual component by three orders of magnitude and the HPLC is unable to quantify these chemicals at these lower concentrations. The chromatograms from the described analysis are included in Appendix K. The results from the HBM analysis did not affect the assessment of the growth study, because all concentrations of the chemicals in the media were too low for detection via HPLC.

To assess growth, samples were analyzed from each reactor at the following time periods (days): before growth solution additional, 1, 4, 7, 10, 13, 16, 19, and 22. Eight reactors, two reactors with each sucrose concentration, were utilized. The samples from

the reactors with the same concentration of starting organic carbon in the growth media were averaged to determine the lipids production for each concentration on each day a sample was collected.

To analyze the total lipids concentration in each sample, a peak determined to be representative of glycerol<sup>33</sup> present in each sample was utilized to quantify growth rate of lipids through the growth cycle. Glycerol was assumed to compose a consistent fraction of the total lipid content in the microalgae throughout the growth process, therefore an increase of glycerol concentration in a sample correlated directly to an increase in lipids content due to microalgae growth.

Ideal growth conditions were determined based on the growth rate of glycerol in each sample. Figure III-2 shows the glycerol peak generated by the response area produced by the RID detector coupled with the HPLC at various times during the growth cycle for each sucrose level. Glycerol peak values increased with increased starting organic carbon concentration and leveled off at around 10 days of growth time. The growth rate increased with increasing starting sucrose concentration level. Therefore, the maximum growth rate may occur at a sucrose concentration level greater than those used in these experiments. However, these data can be used in a future cost benefit study of lipids production relative to organic carbon concentration in the growth media to determine the optimum organic carbon inlet loading.



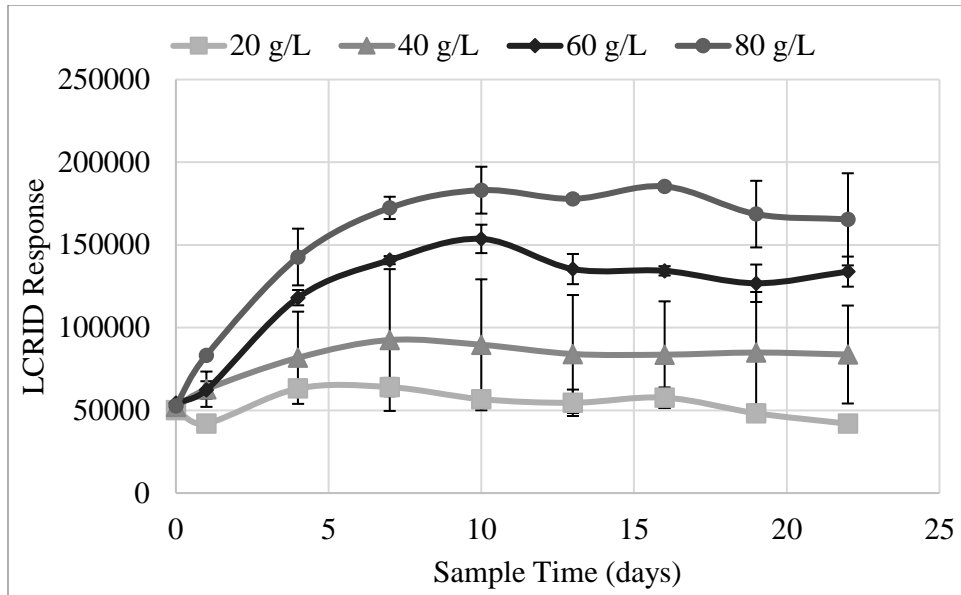

*Figure III-2:* Glycerol peak values as measured by LCRID Respond value for microalgae samples throughout the heterotrophic microalgae growth cycle with different starting concentrations of organic carbon.

Table 2 shows the highest normalized growth rate for each different starting organic carbon concentration in the growth media. These results suggest that while it may be possible to obtain higher overall concentrations of lipids at organic carbon concentrations above the maximum value of 80g/L used in this study, the rate of increase in growth rate begins to decrease between 60-80 g/L. Therefore, the optimum concentration is likely to be near 60 g/L because the benefit of increased lipids production would no longer exceed the increased costs of increased organic carbon loading.

Table III-2: Normalized Increase in Lipids Production (response area per gram of organic carbon) for Each Starting Sucrose Concentration.

Concentration (g/L)	Growth Rate (wt%/day)
20	8.7%
40	10%
60	30%
80	24%

#### 4. Conclusions

- This study demonstrated that an autotrophic strain of *Chlorella Vulgaris* can be adapted to heterotrophic conditions and that the transition is straightforward.
- An optimum concentration of organic carbon in the HBM appears to lie in or near the range of 60-80g/L. However, a cost benefit analysis, coupled with additional research at growth rates above 80 g/L are required to determine the optimum carbon loading.

#### 5. Acknowledgments

The author would like to thank the following for their contributions to this work: Wayne Seames, Andrew Ross, Edward Kolodka, Yun Ji, Ian Foerster, and Maram Al-Sayaghi. Financial support was provided by the National Science Foundation IRES Program [grant number 1458962]. Any opinions, findings, and conclusions or recommendations expressed in this material are those of the author(s) and do not necessarily reflect the views of the National Science Foundation

CHAPTER IV. OPTIMIZATION OF TRIGLYCERIDES AND FREE FATTY ACID  
EXTRACTION FROM AUTOTROPHIC AND HETEROTROPHIC STRAINS OF  
THE MICROALGAE CHLORELLA VULGARIS

## *Abstract*

One challenge to the exploitation of microalgae as a resource for renewable fuels and chemicals is the ability to effectively extract the lipids from the microalgae. While the extraction of lipids, comprised of triglycerides and free-fatty acids (FA oils), from microalgae has been studied extensively at the laboratory scale<sup>34-37</sup> comprehensive studies of the most attractive of the various techniques using a similar and consistent experimental and analytical methodology is missing. The purpose of the research presented herein was to complete a comprehensive study using an autotrophic version of *Chlorella Vulgaris* begun by UND Chemical Engineering Ph.D. candidate Ian Foerster (work not yet published). After optimization, the best method was applied to a heterotrophic version of the same microalgae strain for comparison.

The factors which were optimized included: solvent type (methanol, ethanol, and hexane); the impact on extraction efficiency of mechanical pre-treatment using a ball mill with a variety of grinding speeds; the impact on extraction efficiency of various microalgae-to-solvent ratios; the impact on extraction efficiency when extraction is facilitated by microwave; the impact on extraction efficiency when extraction is facilitated by sonication; the impact on extraction efficiency when extraction is facilitated by increasing temperature; and the impact on extraction efficiency when in-situ transesterification is used to convert the lipids into esters prior to extraction.

The optimum conditions determined during the initial studies of free fatty acid extraction from microalgae were: temperature facilitated extraction at 160°C with a microalgae-to-solvent (g:mL) ratio of 1:9.

## 1. Introduction

One challenge to the exploitation of microalgae as a resource for renewable fuels and chemicals is the ability to effectively extract the lipids from the microalgae. While the extraction of lipids, comprised of triglycerides and free-fatty acids (FA oils), from microalgae has been studied extensively at the laboratory scale,<sup>34-37</sup> a comprehensive study of the most attractive of the various techniques using a similar and consistent experimental and analytical methodology is missing. The purpose of the present research is to complete a comprehensive study using an autotrophic version of *Chlorella Vulgaris* begun by UND Chemical Engineering Ph.D. candidate Ian Foerster (work not yet published). After optimization, the best method was applied to a heterotrophic version of the same microalgae strain for comparison.

Three categories of lipid leaching strategies are common in the literature: mechanical, physical, and chemical. Mechanical extraction techniques include an expeller and an oil press, both of which are commonly used with oilseed crops. However, these methods by themselves have been found to be ineffective in removing the lipids from microalgae<sup>38</sup>.

Physical extraction techniques include ball milling, microwave, sonication, and supercritical fluid extraction. Ball milling, microwave and sonication are cell disruption techniques used to rupture the cell walls to allow for easier passage of lipids out of the cell. Microwave and sonication methods have been reported as effective but energy intensive methods<sup>38</sup>.

Chemical extraction techniques include solvent extraction, an exhaustive leaching of microalgae via Soxhlet, or the Bligh-Dyer method.<sup>39, 40</sup> Non-polar solvents, such as

hexane, have most commonly be utilized for fatty acid extraction.<sup>41, 42</sup> Unfortunately in microalgae, non-polar solvents are unable to penetrate the cell due to the strong hydrogen bonds which are formed between the membrane associated with the lipids and the proteins in the cell. A method using a mixture of a polar and non-polar solvent has been studied to utilize a polar solvent to disrupt the hydrogen bonds in the cell and the non-polar solvent to extract the oil. Several different pure solvents and combination of solvents have been studied at length. Some of the solvents used in different combinations include chloroform, methanol, dimethyl sulfoxide, hexane, isopropanol, ethanol, and acetonitrile<sup>40</sup>. As the results from these individual studies are not always consistent, a screening study was performed as part of a previous study to identify the best solvents for more detailed study<sup>12</sup>. An additional technique that might enhance solvent extraction is to react the acidic groups of the lipids with lower order alcohols to generate esters. This technique is known as in-situ transesterification<sup>43</sup>. Excess alcohol then acts as a solvent to extract the esters<sup>44</sup>.

For all chemical extraction methods, an efficient microalgae-to-solvent ratio is necessary if the method is to be commercially feasible. Previous work identified the large quantity of solvent in comparison to the low concentration of lipids in the extraction product as a limiting factor for scale-up<sup>11</sup>. The ratio utilized in that study was 1.0 g microalgae:10 mL solvent (methanol). The present work includes an optimization of the microalgae-to-solvent ratio for the most promising solvents.

The purpose of the research presented herein was to complete a comprehensive study of the most attractive of the various techniques previously reported for optimization of microalgae lipid extraction using an autotrophic version of *Chlorella Vulgaris* and to

then apply this best method to a heterotrophic version of the same microalgae strain. Extensive research has been done to identify ideal microalgae strains in order to increase lipids production, biomass growth rate and density, and to minimize nutrient consumption, environmental impacts, invasive biologicals and other external factors<sup>1</sup>. Of the hundreds of different strains of microalgae commercially available, a strain which has proven to yield a high lipids content is *Chlorella Vulgaris* which is also one of the fastest growing microalgae strains<sup>2</sup>. Additionally, this strain of microalgae has been found to be amenable to heterotrophic adaptation<sup>3</sup>.

This study builds from the knowledge obtained in a study produced by Foerster, et. al.<sup>12</sup> and the challenges identified in Chapter II of this Thesis.

## *2. Materials and Methods*

### *2.1 Materials and Reagents*

Two sources of autotrophic *Chlorella Vulgaris* microalgae were used. The first source was cultured at the University of Leeds, Leeds, England from the original 80-120 mesh, freeze-dried strain purchased from Qingdao Sunrise Trading Co., Ltd., Qingdao, China. The second source was obtained from Carolina Biological Burlington, NC, USA and inoculated into a Bolds Basal Media (BBM) growth solution (Item # 152075), defined in Appendix J.1. A Heterotrophic Basal Media (HBM) growth solution, defined in Appendix J.2, was used to culture, adapt, and grow heterotrophic *Chlorella Vulgaris* microalgae as described below under *Methods*. The growth of the second variety of autotrophic *Chlorella Vulgaris* and the adaptation of this culture to heterotrophic *Chlorella Vulgaris* was completed at the University of North Dakota, Grand Forks, ND USA.

The following chemicals were utilized to produce the BBM and HBM growth solutions. Sodium Nitrate was purchased from Fisher Scientific, product number 7631-99-4. Calcium Chloride was purchased from Fisher Scientific, product number C70-500. Magnesium Sulfate Heptahydrate was purchased from Fisher Scientific, product number 10034-99-8. Dipotassium Hydrogen Phosphate was purchased from Sigma Aldrich, product number P3786-100G. Potassium Dihydrogen Phosphate was purchased from Fisher Scientific, product number 7778-77-0. Sodium Chloride was purchased from Fisher Scientific, product number 7647-14-5. Copper Sulfate Pentahydrate product number 60-004-59, molybdenum trioxide product number ICN15254880, zinc sulfate heptahydrate product AC205982500, manganese chloride tetrahydrate product M87-100, cobalt nitrate hexahydrate product AC213091000 were all purchased from Fisher Scientific to generate Trace Element Solution. EDTA was purchased from Sigma Aldrich, product number ED2SSS-50G. Acidified Iron Stock Solution was purchased from Fisher Scientific, product number 7782-63-0. Boric Acid was purchased from Fisher Scientific, product number A74-500. 2.3 kg bags of American Crystal brand sugar was obtained locally for use as the organic carbon source for the heterotrophic strain. Yeast Extract was purchased from Fisher Scientific, product number 8013-01-2.

The following solvents were used in the preliminary study of potential solvents, as described in the experimental section below: chloroform, methanol, hexane, acetonitrile, ethanol and deionized water. Subsequent experiments were performed using methanol, ethanol, and hexane. High purity solvents were purchased from Fisher Scientific (ethanol product number BP28184, hexane product number H2924, and methanol product number A433S20). Hydrochloric acid purchased from Fisher Scientific (product number



A142212), was utilized in the examination of the feasibility of in-situ transesterification for the extraction of microalgae oil.

Dichloromethane (DCM) purchased from Fisher Scientific (product number AC406920040) was utilized in sample preparation for Thermal Carbon Analysis (TCA) to suspend the extraction products in solution.

## *2.2 Experimental Setups*

An International Equipment Company (IEC) HN-SII Centrifuge, was used to obtain a concentrated slurry of microalgae before freeze drying. The centrifuge was operated at 2000 rpm for 10 minutes with 4 x 250 mL high density polyethylene bottles to concentrate several liters of microalgae suspended in growth solution to less than 25 mL of slurry.

A FreeZone Freeze Dryer (Kansas City, Missouri), was used to dehydrate and preserve the microalgae for future use. Additionally, freeze drying acts as an initial method to crack the cell wall which aids solvent extraction. Freeze drying cracks the cell walls by first freezing the microalgae slowly to form large intracellular ice crystals before exposing the sample to a low pressure and temperature around 1 kPa and -40°C causing the ice crystals to sublime to dry the microalgae<sup>45</sup>.

A Retsch MP100 Planetary Ball Mill (Retsch, Haan, Germany), was used to crack the microalgae cell walls to facilitate more efficient solvent extraction. Planetary ball mills yield a well-mixed sample with a high degree of fineness. Additionally, planetary ball mills provide high pulverization energy which leads to shorter grinding times<sup>4</sup>. The revolution rate in this unit could be varied. Therefore, the rate of grinding was also explored to identify the optimum condition to crack the cell walls.

A Milestone StartSYNTH Microwave Synthesis Labstation<sup>46</sup> (Milestone, Sorisole, Italy) was used in selected experiments to further crack the microalgae cell walls and to facilitate more efficient solvent extraction.

Another wave-based method to disrupt microalgae cells is sonication. A Fisher Scientific 5.7L Ultrasonic Bath (Fisher Scientific, Denver, USA) was also used in selected experiments to further crack the microalgae cell walls and facilitate more efficient solvent extraction.

Another method to increase the internal energy of microalgae in order to facilitate extraction is to increase the temperature of the algae-solvent solution. To explore this option, a small-scale batch reactor, Figure IV-2, built with a repurposed gas chromatography oven to allow temperature control, was used in selected experiments. A turntable attached to a motor with clasps to hold each sample in place provided agitation in the reactor. The small-scale batch reactor allowed temperature to be tested as a method to facilitate extraction without any additional cell wall disruption techniques being utilized.



*Figure IV-1: Small Batch Reactor used in Temperature Studies*

### *2.3 Experimental Methods: Microalgae Lipid Extraction*

Several factors were examined to determine the effect on lipid extraction efficiency, including solvent choice, mill grinding speed, microalgae-to-solvent ratio, microwave facilitated extraction, sonication facilitated extraction, temperature facilitated extraction, and in situ transesterification facilitated extraction.

A preliminary study was completed which analyzed a wide range of solvents for lipids extraction from autotrophic microalgae. The solvents utilized in the initial study

were chloroform, methanol, hexane, acetonitrile, ethanol and DI water. Subsequent experiments were performed using methanol, ethanol, and hexane. Methanol was chosen as it was determined to yield the highest extraction efficiency in the preliminary study. Ethanol was chosen to provide a similar solvent derived from a renewable feedstock while hexane was chosen as it is the traditional solvent of choice for triacylglyceride extraction from oil seeds (e.g. soybean, canola) and thus provides a standard for comparison with other solvents and also with other fatty acid generating resources (such as oil seeds).

The efficiency of the three chosen solvents was studied by examining the following factors: grinding speed, microalgae-to-microalgae ratio, microwave facilitated extraction across several temperature profiles, sonication facilitated extraction, temperature facilitated extraction, and in situ transesterification facilitated extraction.

Each extraction experiment was performed in triplicate with each of three solvents (methanol, ethanol, and hexane) with the following procedure. Eighty-two separate experimental conditions were chosen as summarized in Table IV-1. Appendix M lists the experimental conditions for each of the 82 tests. A German Retsch MP100 Planetary Ball Mill, was used in conjunction with samples of microalgae from the University of Leeds at various speeds depending on the desired test condition. Three samples of microalgae containing approximately 1.0 g each at each grinding speed were weighed and inserted into the reaction vessel. Each experimental trial in the triplicate set was performed simultaneously, with each triplicate set being performed subsequently.

Solvent was combined with the microalgae in a fashion to evenly suspend the microalgae in the solution. The reaction vessel was inserted into the required equipment set up for each reaction condition. The microalgae and solvent were allowed to be in

contact for 25 minutes. After 25 minutes, the reaction vessel was removed from the experimental apparatus and emptied into a pre-weighed 12.5-centimeter double ring 102 filter paper. The vessel was rinsed with additional solvent to remove all residual microalgae from the vessel. The liquid was collected in a pre-weighed container. The containers of liquid were dried in a drying oven at 50°C until all the solvent had evaporated. The filter with the residual microalgae was also dried in a drying oven at 50°C until any residual solvent had evaporated. The weight of the filter and the container after drying were recorded to determine the total residual microalgae and extractant.

### *2.3.1 Grinding Study Methods*

The effect of grinding on extraction efficiency was determined before any additional experimentation was completed. Tests were performed with unground and with samples that had been ground in the ball mill at 200, 300 400, 500, and 600 rpm. The solvent extraction procedure was performed without any additional cell disruption technique.

Table IV-1: A Summary of the Experiments Performed in this Study (a more complete list is provided in Table S1)

Experimental Set →	Grinding Study	Solvent Study I	Solvent Study II	Solvent Study III	In Situ Transesterification Study	Microwave Study	Temperature Study	Optimization Study
<b>Number of Experiments</b>	15	18	15	5	4	15	10	3
<b>Microalgae Type<sup>1</sup></b>	UoL A	UoL A	UoL A	UoL A	UoL A, UND H	UoL A	UoL A	UoL A, UND A, UND H
<b>Solvent<sup>2</sup></b>	M, E, H	M, E, H	M, E, H	M	M, E	M	M	M
<b>Mill Grinding Speed (RPM)</b>	200, 300, 400, 500, 600	500	500	500	500	500	500	500
<b>Microalgae-to-Solvent Ratio (g<sub>biomass</sub>/mL)</b>	10:1	1:3, 1:7, 1:10, 1:11, 1:15, 1:19	1:7, 1:8, 1:9, 1:10, 1:11	1:8, 1:8.5, 1:9, 1:9.5, 1:10	1:10	1:10	1:10	1:9
<b>Temperature (°C)</b>	25	80	25	25	80	25, 50, 80, 110, 140	25, 50, 80, 110, 140, 150, 160, 170, 180	160
<b>Microwave-Assisted</b>	-	+	-	-	+	+	-	-
<b>Temperature-Assisted</b>	-	-	-	-	-	-	+	+
<b>Sonicator-Assisted</b>	-	-	+	+	-	-	-	-
<b>Transesterification (HCl Addition)</b>	-	-	-	-	+	-	-	-

<sup>1</sup> UoL = performed at University of Leeds, UK; UND = performed at University of North Dakota, USA; A = autotrophic; H = Heterotrophic

<sup>2</sup> M = methanol; E=ethanol; H=hexane

<sup>3</sup> + = Method employed in listed experiments, - = Method not employed in listed experiments

### *2.3.2 Microalgae-to-Solvent Ratio Study Methods*

The effect of the microalgae-to-solvent ratio on the extraction efficiency was completed in three studies. The first study utilized microwave facilitated extraction at 80°C to analyze a wide range of microalgae-to-solvent ratios. An operating temperature of 80°C was chosen to allow all extractions performed with methanol, ethanol, and hexane to be completed at the same temperature. The microalgae-to-solvent ratios (g to mL) which were initially studied were 1:3, 1:7, 1:11, 1:15, and 1:19. Each ratio was performed with microwave and methanol, ethanol or hexane.

The second study utilized extraction facilitated by sonication to analyze a narrow range of ratios. The microalgae-to-solvent ratios (g to mL) which were studied were 1:7, 1:8, 1:9, 1:10, and 1:11. Each ratio was performed with sonication and methanol, ethanol or hexane. The third study utilized extraction facilitated by sonication to analyze an even narrower range of ratios. The microalgae-to-solvent ratios (g to mL) which were studied were 1:8, 1:8.5, 1:9, 1:9.5, and 1:10. Each ratio was performed with sonication and methanol.

### *2.3.3 Microwave study methods*

The effect of microwave facilitated extraction on efficiency was determined by performing the extraction protocol with the use of microwave at several temperatures. By utilizing microwave at various temperatures, the effect of microwaves can be directly compared to extraction efficiency due to temperature without microwave. Microwave facilitated extraction experiments were performed at 25, 50, 80, 110, and 140°C with either methanol, ethanol or hexane as the solvent. 140°C was the upper limit due to pressure and temperature limitations in the microwave system. No 140°C experiments were performed

with hexane. When operating with hexane at temperatures of 110°C and above, the microwave P&ID controller was unable to properly analyze the internal temperature of the mixture and continued to call for power to heat beyond the temperature set point.

#### *2.3.4 Sonication study methods*

The effect of sonication facilitated extraction for increased efficiency was determined by performing the extraction protocol with the use of sonication across several microalgae-to-solvent ratios and with an operating temperature of approximately 25°C. These results could then be compared to other cell disruption techniques for impact on extraction efficiency. Experiments were performed at each ratio with sonication and methanol.

#### *2.3.5 Temperature study methods*

The effect of temperature facilitated extraction on efficiency was determined by performing the extraction protocol with two different techniques. The first technique was the use of a small batch reactor (Figure IV-3) across the same temperature profiles as analyzed with the microwave, 25, 50 and 140°C, as well as 200°C to determine if a temperature over 140°C would indicate an increase in extraction efficiency. The second technique utilized Ace Glass Incorporated Pressure Tubes (Catalog #: 8648-07; Vineland, NJ USA) heated in an oven at temperatures that ranged from 140°C to 180°C in increments of 10°C. These experiments allow the impact of temperature on extraction efficiency to be isolated from the other methods.

During an initial temperature facilitated extraction study, experiments were performed at 25, 50, 140, and 200°C with methanol, ethanol or hexane as the extraction solvent. Due to vapor-liquid equilibrium thresholds, 200°C was the upper limit for ethanol

or hexane. Since 200°C was the upper limit for two of the studied solvents, 200°C was the maximum temperature tested for all three solvents. A subsequent temperature facilitated extraction study was performed to optimize the operating temperature during each extraction. For this study, experiments were performed at 140, 150, 160, 170, and 180°C with methanol as the extraction solvent.

### *2.3.6 In situ transesterification methods*

The effect of in-situ transesterification facilitated extraction on efficiency was determined by performing the extraction protocol with the additional of a small quantity of hydrochloric acid. The in-situ transesterification was performed with two feedstocks, the autotrophic strain of microalgae from the University of Leeds and the heterotrophic strain of microalgae produced at the University of North Dakota. This technique was used in conjunction with microwave-assisted extraction at a temperature of 80°C. The experiments were performed with each strain and with either methanol or ethanol and a drop of HCl in the 10 mL of solvent in the quartz microwave reaction vessel.

### *2.3.7 Optimization study methods*

The optimum conditions determined during the initial studies of free fatty acid extraction from microalgae were: temperature facilitated extraction at 160°C with a microalgae-to-solvent (g:mL) ratio of 1:9. When temperature facilitated extraction was compared to microwave facilitated extraction at an identical temperature of 140°C, microwave facilitated extraction efficiency was 1% greater on the basis of fraction of inlet carbon extracted. However, microwave requires a high energy input and was not capable of operating above 140°C. The optimum solvent was determined to be methanol, as it performed the best throughout the study in comparison to ethanol and hexane.



The extraction efficiency achieved using temperature facilitated extraction in the small batch reactor at temperatures above 140°C exceeded the maximum efficiencies achieved in the microwave. Therefore, additional experiments were completed to identify the near optimum conditions. The final optimization experiments to compare the maximum extraction efficiency obtainable were performed with three different feedstocks, an autotrophic strain of *Chlorella Vulgaris* obtained from the University of Leeds, an autotrophic strain of *Chlorella Vulgaris* grown at the University of North Dakota, and a heterotrophic strain of *Chlorella Vulgaris* grown at the University of North Dakota. The operating conditions of the optimized experiments were methanol solvent with a microalgae-to-solvent ratio of 1:9 and an extraction temperature of 180°C with no microwave or sonication.

#### 2.4 Analytical Methods

Gravimetric analysis and thermal carbon analysis (TCA) were used to analyze the extraction products and to determine the optimum conditions. Gravimetric results were obtained by filtering the extraction solution to separate the residual solids from the free fatty acid rich solvent mixture. The liquids and solids were then dried to evaporate any remaining solvent and weighed.

TCA results were obtained from the liquid samples containing the lipids by fractioning a small portion of the fatty acids to be dissolved in dichloromethane (DCM). 10 µL of each sample was loaded onto a Pall Flex 2500QAT-UP tissue quartz filter (Pall Corp. East Hills, NY). The sample was dried at 40°C for 4 minutes to evaporate the DCM before analysis. TCA was completed utilizing a thermal optical analyzer from Sunset Laboratory Inc. (Portland, OR). The lipids were assumed to elute in the 300°C and 400°C

fractions based on the work of Lima et. al. which focused on the pyrolysis reactions of oils<sup>56</sup>. A sucrose (40 µg of loaded carbon) run was used as a daily external calibration. All samples were analyzed in duplicate.

### 3. Results and Discussion

The main objectives for the described work were to optimize the extraction conditions to remove lipids from the autotrophic strain of *Chlorella Vulgaris*, and then to utilize these conditions to extract lipids from a heterotrophic strain of *Chlorella Vulgaris* grown in-house for comparison. In order to optimize the extraction of the lipids, several different factors were studied as shown in Table 1. For each set of experimental conditions results for both the solid and liquid product fractions were analyzed.

#### 3.1 Grinding Study Results

The first factor analyzed was optimizing the ball mill speed for the mechanical pre-treatment of the microalgae. The gravimetric results from the 18 experiments performed in triplicate for lipid extraction at different grinding conditions are summarized in Figure IV-4. This figure shows the liquid collected after solvent leaching reported as the mass fraction of the initial algae recovered (wt%). The figure indicates that with no grinding as the mechanical pre-treatment for extraction, for methanol, ethanol and hexane, respectively less than a 6 wt%, 2 wt%, and 1 wt% recovery was achieved, respectively. The figure also shows that as the speed of grinding increases so does the recovery. Therefore, it can be concluded that grinding the microalgae with a planetary ball mill increases overall yield. It was determined that grinding the microalgae at 500 rpm resulted in a 9 wt%, 5 wt%, and 1 wt% or greater recovery for methanol, ethanol and hexane, respectively which was the optimum pretreatment condition, as speeds above 500 rpm generated no additional lipid

during extraction. This conclusion is consistent with the findings from previous studies which suggest mechanical pre-treatment should be performed before performing a chemical extraction<sup>47</sup>.

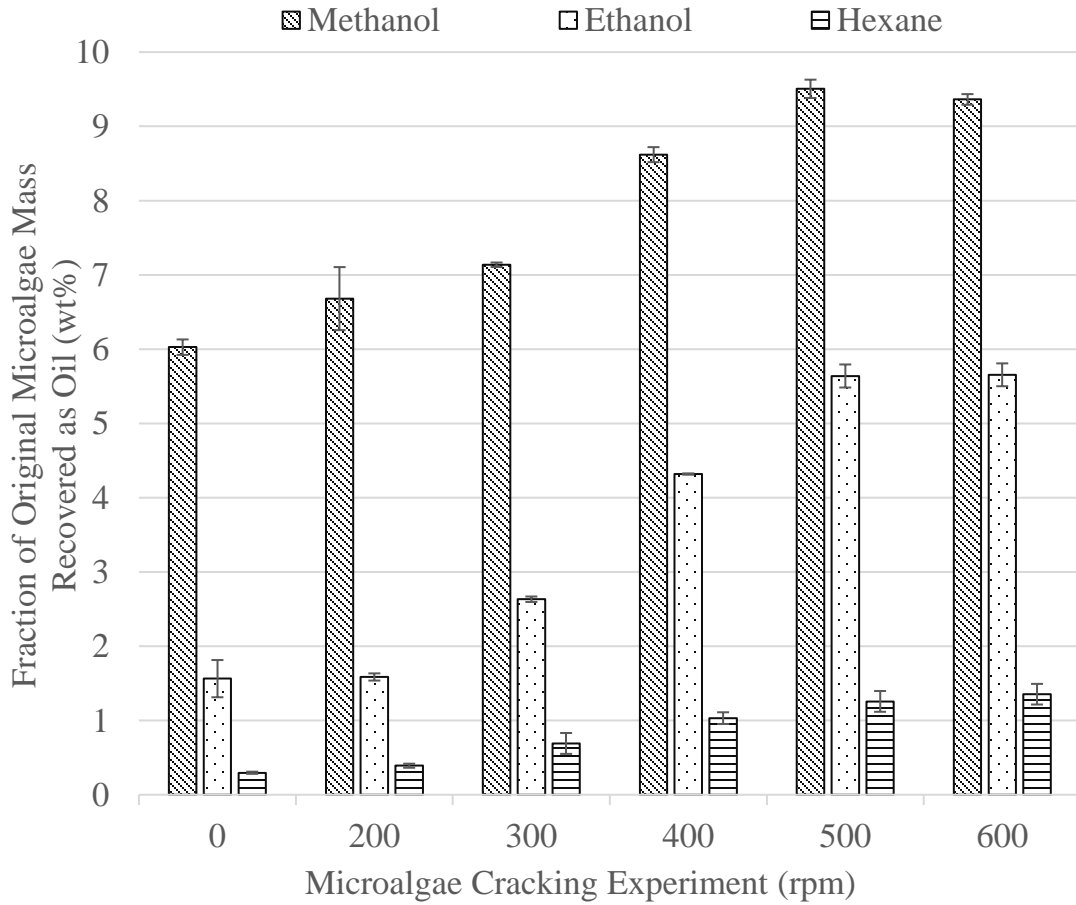

Figure IV-4: Effect of cell wall rupture due to grinding gravimetric results.

### 3.2 Microalgae-to-Solvent Ratio Study Results

The second factor analyzed was the microalgae-to-solvent ratio which was completed in three studies. Finding an optimum microalgae-to-solvent ratio is a key component for scaling up to an industrial scale as handling a large quantity of solvent

greatly increases the overall cost of the process. Further, as the microalgae-to-solvent ratio decreases the difficulty of separation of the solvent from the lipids increases.

Each of the three studies were performed using microalgae pretreated at the optimum grinding speed of 500 rpm described in section 3.1. In the first study, a wide range of microalgae-to-solvent ratios were tested based on previous literature results, with the objective of bounding the optimum ratio.

The gravimetric results from the initial 15 experiments are summarized in Figure IV-5. This figure shows the liquid collected after solvent leaching reported as the mass fraction of the initial algae recovered (wt%). The ratio of 1:3 produced the lowest extraction at approximately 11 wt%, 9 wt%, and 3 wt% recovery for methanol, ethanol and hexane, respectively. The recovery increased with the ratios of 1:7 and 1:11 but plateaued after 1:11. It was concluded that the ideal ratio of microalgae-to-solvent ratio is between 1:7 and 1:11 as ratios beyond 1:11 generate no additional lipids.

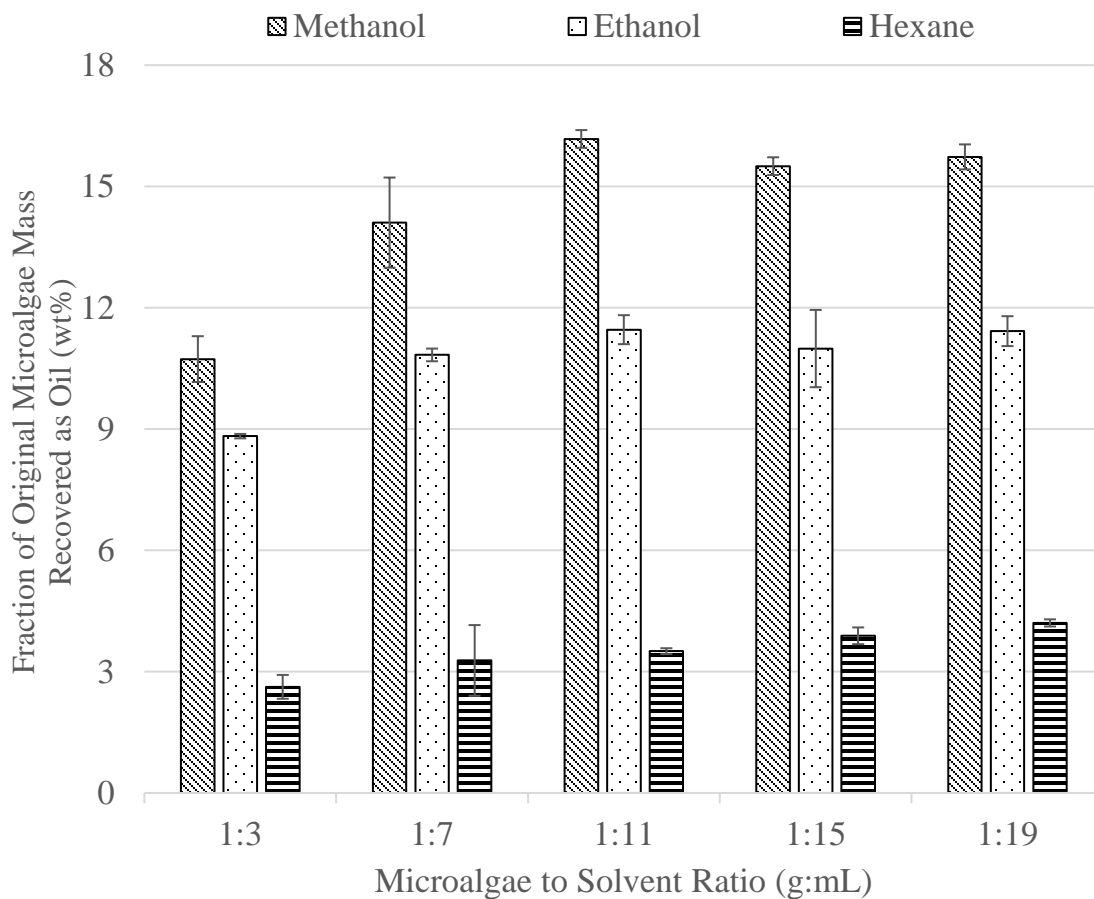

Figure IV-5: Effect of microalgae to solvent ratio with microwave gravimetric results.

The second study analyzed a smaller range of ratios, all of which fell in between the ratios studied in the previous study, to determine the optimum microalgae-to-solvent ratio. Figure IV-6 shows the liquid collected after solvent leaching reported as the mass fraction of the initial algae recovered (wt%) for the triplicated experiments at the 15 conditions of the second study. Figure IV-7 shows the fraction of the original lipids extracted at each condition (wt%) from the initial mass of microalgae. This fraction was calculated using TCA results from the extracted oil sample compared to TCA results from the original microalgae biomass. The combined mass in the 300°C and 400°C temperature fractions for the extracted oil was divided by the combined mass in the 300°C and 400°C

temperature fractions measured in the microalgae feedstock. The overall recovery for this second study is lower than the initial ratio study as this was completed with sonication at 25°C instead of microwave at 80°C. The recoveries measured at a ratio of 1:11 were under 8, 2, and 1 wt% of the initial microalgae mass for methanol, ethanol and hexane, respectively whereas in the initial study the ratio of 1:11 yielded over 16, 12, and 3 wt% recovery. However, the results still display the same trend and indicate that the optimum extraction ratio falls between 1:7 and 1:11. It was determined that extraction efficiency of lipids from microalgae is optimized at a ratio of microalgae-to-solvent ratio between 1:8 and 1:10 as ratios beyond 1:10 generate no additional extraction.

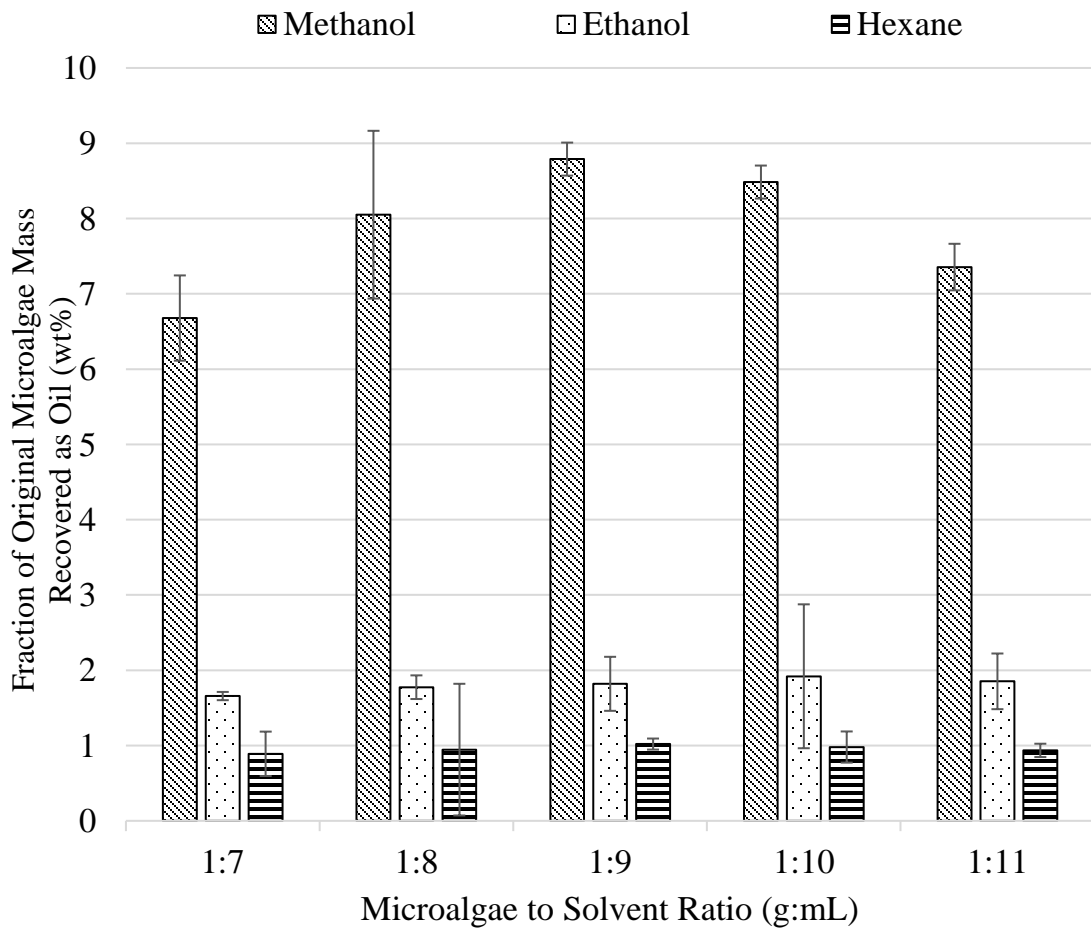

Figure IV-6: Effect of microalgae-to-solvent ratio with sonication on lipids extraction; gravimetric results.

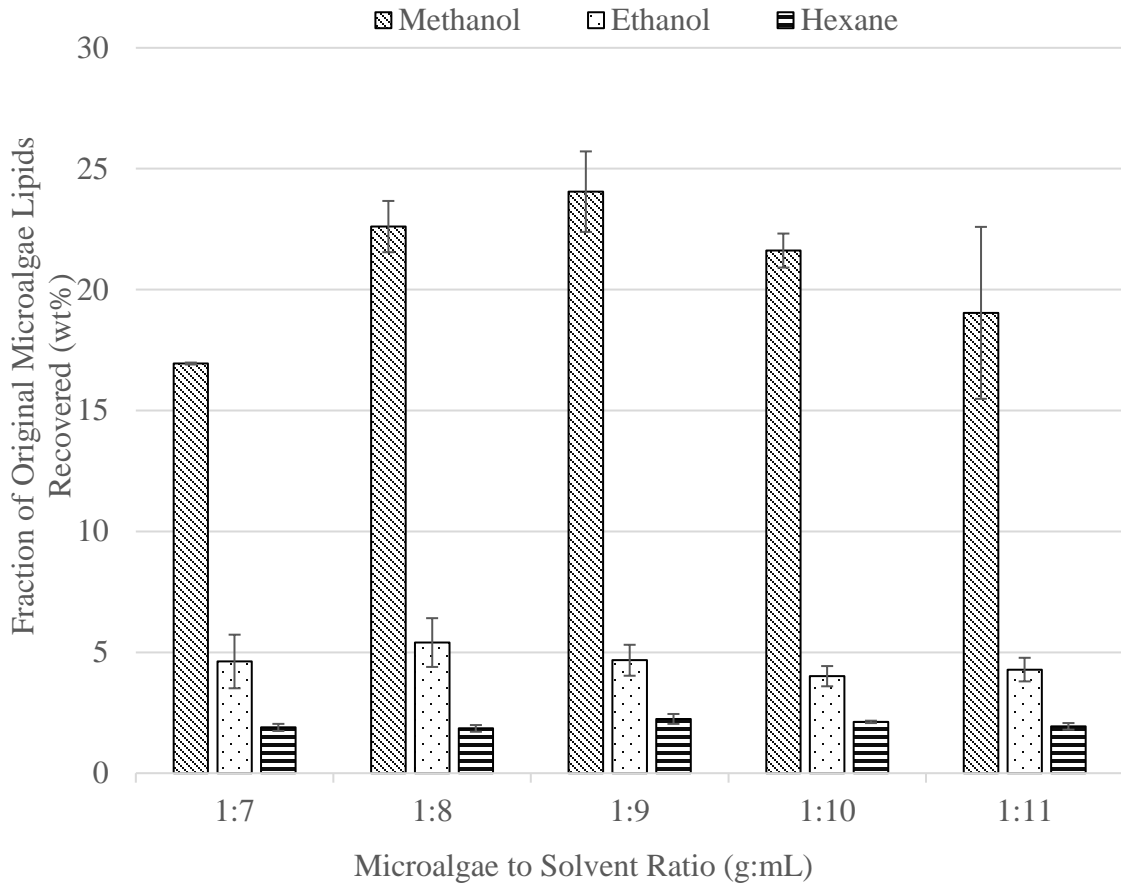
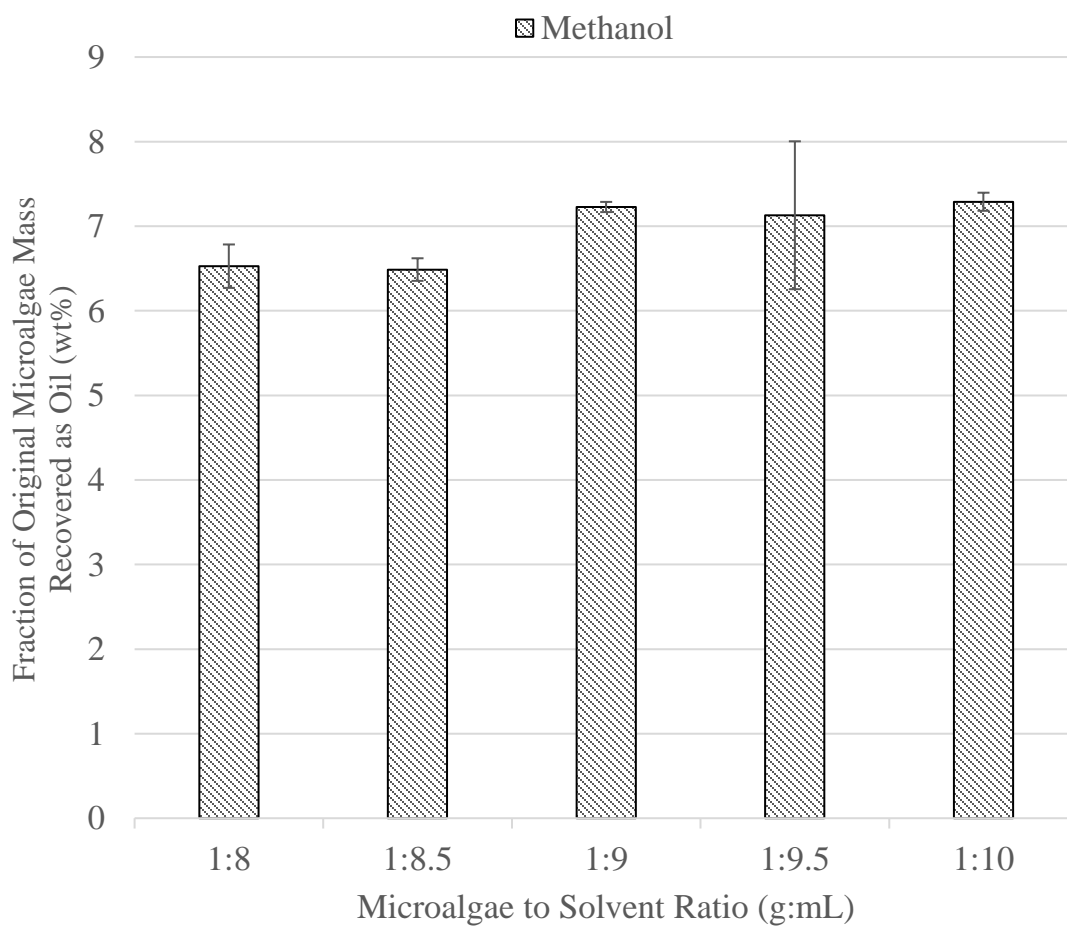

Figure IV-7: Effect of microalgae-to-solvent ratio with sonication on lipids extraction; thermal carbon analysis results.

In the third study, five experiments were performed in triplicate for the range 1:8 through 1:10. The results, Figure IV-8, are displayed as the liquid collected after solvent leaching reported as the mass fraction of the initial algae recovered (wt%). Figure IV-9 represents the fraction of the original lipids extracted at each condition, calculated the same as for Figure IV-7. It was determined that extraction efficiency of lipids from microalgae is optimized with a microalgae to solvent ratio of 1:9.



*Figure IV-8:* Effect of solvent-to-microalgae ratio with sonication on lipid extraction; gravimetric results.



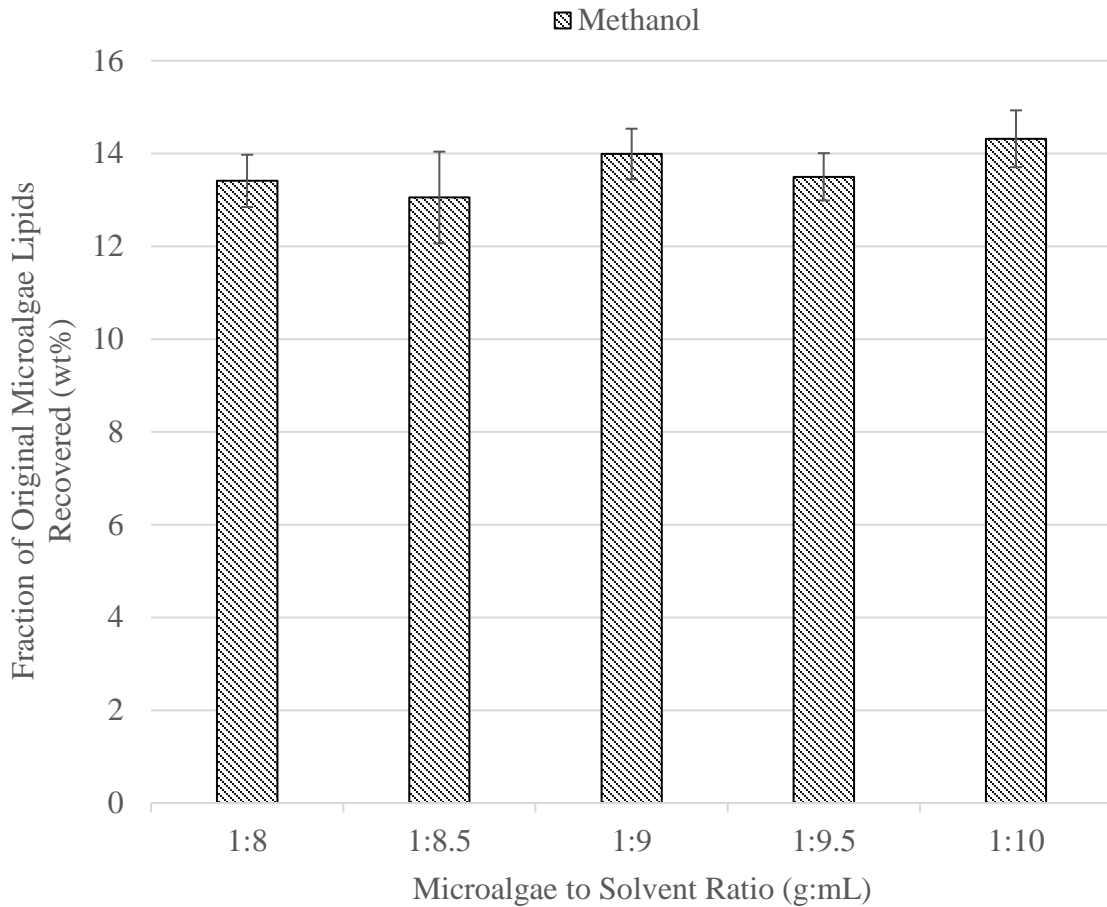

*Figure IV-9:* Effect of solvent to microalgae ratio with sonication on lipid extraction; thermal carbon analysis results.

The optimum solvent (methanol) and ratio (1:9) shown in Figure IV-8 compares favorably with those reported in previous studies: 1:10 (g to mL) with a mixture of chloroform/methanol<sup>48</sup>, 1:15 (g to mL) with a mixture of chloroform/methanol<sup>49</sup>, 1:15 (g to mL) with a mixture of hexane/isopropanol<sup>49</sup>, 1:15 (g to mL) with a mixture of hexane/isopropanol<sup>49</sup>, and 1:10 (g to mL) with a mixture of methanol<sup>50</sup>. These studies produced lipid yields from 2 to 14 wt% with respect to the quantity of lipids in the original biomass compared to the 14% found in the present work. This result is significant because

the microalgae-to-solvent ratio is one of the remaining major barriers for scaling up microalgae lipid/oil extraction processes.

### *3.3 Microwave Study Results*

The third factor analyzed was the effect of microwave for the enhancement of lipid extraction. Microwave facilitates extraction by generating heat from within the cell due to friction generated by molecular movement inside the cell walls, primarily provided by entrained water inside the cell vaporizing due to the microwaves<sup>45</sup>. Additionally, microwave facilitated extraction may be a promising method to facilitate increased solvent extraction efficiency as it can decrease extraction time and solvent consumption<sup>51</sup>.

The microwave study was performed using microalgae that had been pretreated by grinding at the optimum 500 rpm and at microalgae-to-solvent ratios which fell within the range determined in the initial ratio study. The gravimetric results from the 15 experiments performed in triplicate for the microwave study are summarized in Figure IV-10. Comparing Figure IV-10 to Figure IV-4, the 25 °C microwave test mimics the result of the 500 rpm grinding study experiments, and as microwave temperature is increased, lipid recovery is increased by 15%, 11%, and 6 wt% of the initial microalgae mass for methanol, ethanol and hexane, respectively. Figure IV-11 represents these data as the fraction of the original lipids extracted for each sample from the initial mass of microalgae. This result was determined following the procedure described above for Figure IV-7. Figure IV-10 and Figure IV-11 both support the conclusion that increased microwave temperature increases solvent extraction efficiency. TCA analysis was only completed on a few select experiments for the microwave extraction experiments, therefore since 140°C was not completed for hexane, the experiment at 110°C was analyzed. It was determined

that extraction efficiency of lipids from microalgae increases with increased microwave temperature. Due to microwave temperature limitations, the optimum operating conditions were not bounded.

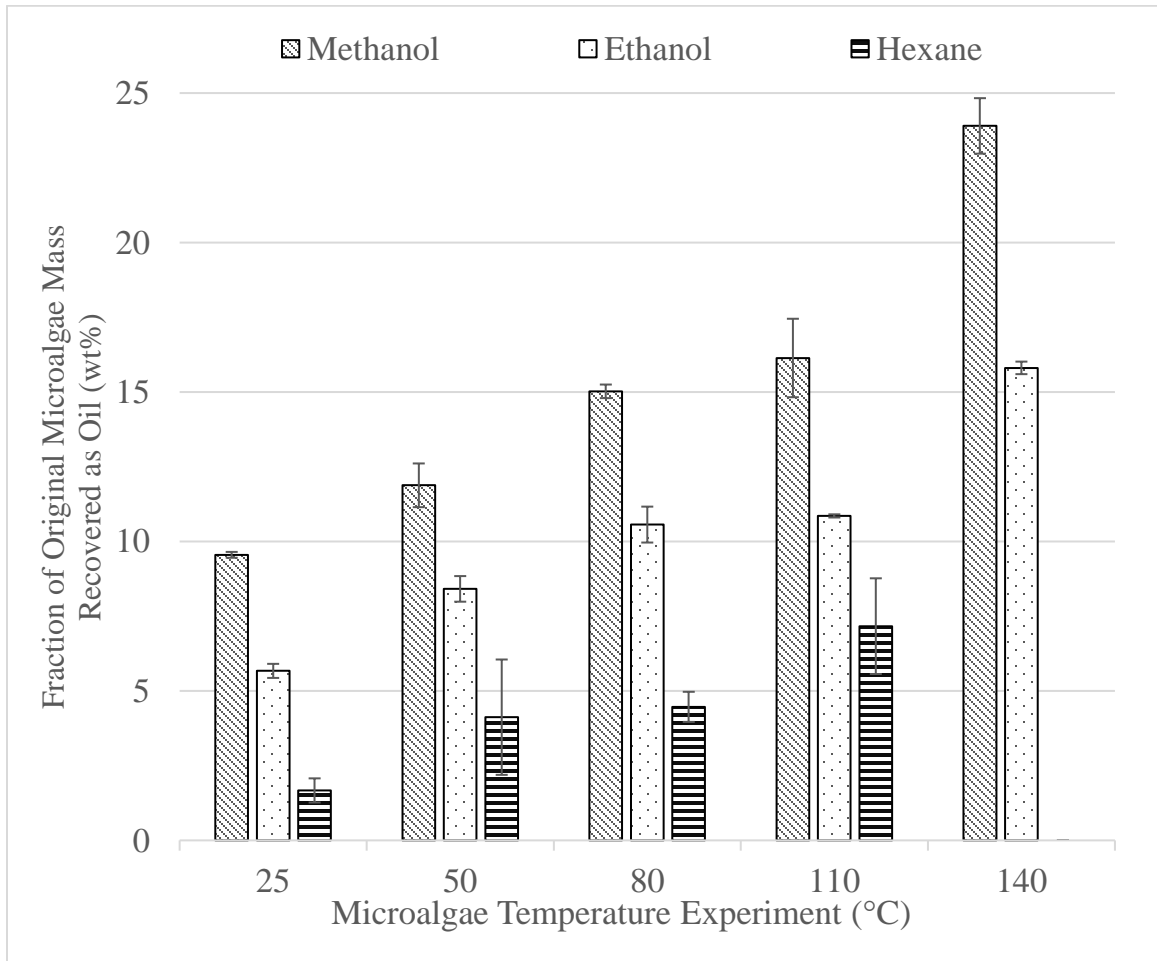

*Figure IV-10:* Effect of microwave facilitated extraction on lipid extraction; gravimetric results

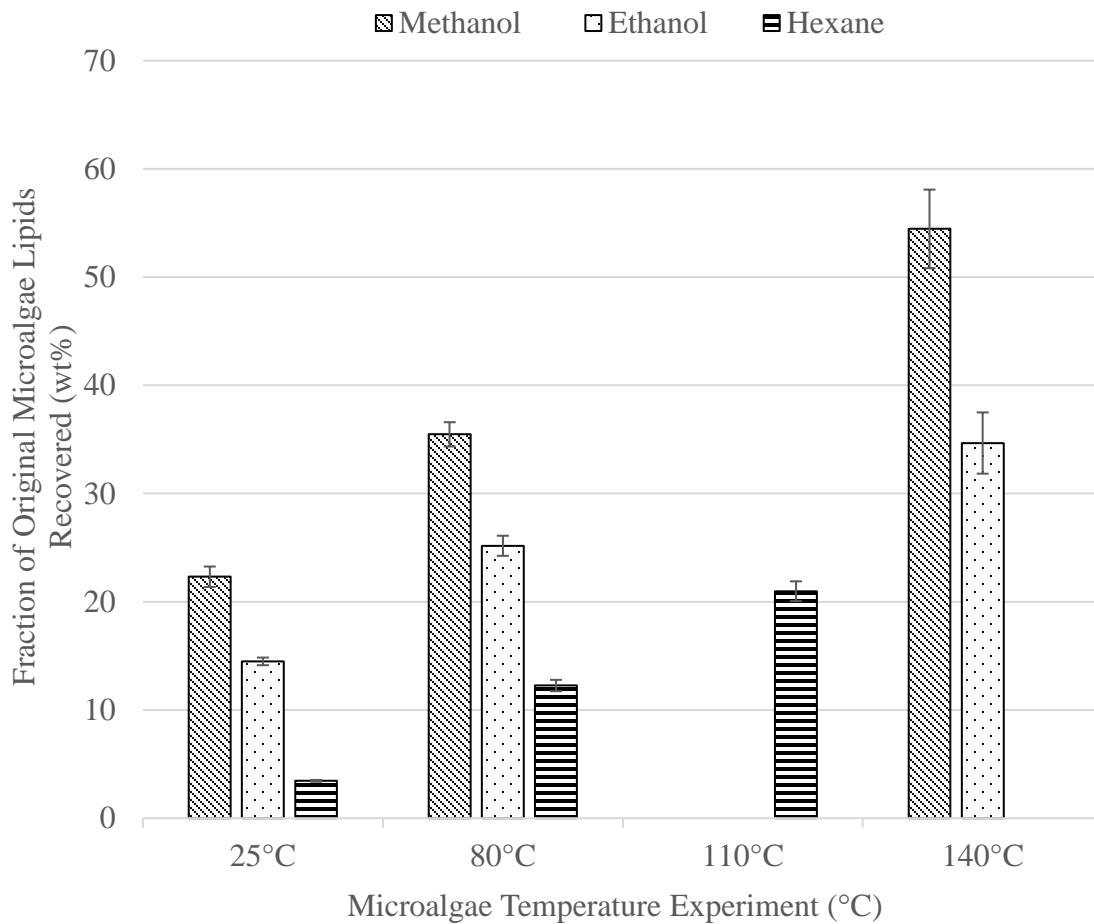

Figure IV-11: Effect of microwave facilitated extraction on lipid extraction; TCA results

A review article by Menegazzo and Fonseca<sup>38</sup> highlights a variety of methods studied to enhance lipid recovery from microalgae and it indicates microwave facilitated extraction yields the highest recovery, which is consistent with the findings of the current study. Previous studies have indicated similar results for microwave facilitated extraction. One such study yielded 17% lipids with microwave facilitated extraction of *Chlorella Vulgaris* at 100°C with a reaction time of 5 minutes<sup>38</sup>. A second study yielded 11% lipids with microwave facilitated extraction of *Chlorella Vulgaris*. The discussed yields from literature are assumed to be percent recovery of initial microalgae feedstock<sup>52</sup>.

However, we observed that the combined effect of increasing extraction temperature with the presence of microwaves had a greater effect on extraction than the effect of the microwave alone. Additionally, the use of temperature to facilitate extraction without other extraction methods was not discussed in the journal review. This observation led to further testing via temperature facilitation to compare the effect of microwave and the effect of temperature, as described in section 3.5, below.

#### *3.4 Sonication study Results*

The fourth factor analyzed was the effect of sonication for the enhancement of lipid extraction. Sonication facilitates extraction by providing ultrasonic waves to cause disruption to the cell wall through rapid compression and decompression cycles. The cycling of ultrasonic waves produces cavitation which will instigate changes in the cell wall<sup>45</sup>. We postulated that sonication facilitated extraction could aid in solvent extraction through a technique which is less energy intensive than microwave facilitated extraction.

The sonication study includes the optimized grinding conditions for the pre-treatment of microalgae and a microalgae-to-solvent ratio which falls within the range determined in the initial study of the ratio. The gravimetric results from the 20 experiments performed in triplicate for the sonication study was used to generate Figure IV-6. This figure is the gravimetric result of the collected liquid from the solvent leaching and is reported as percent recovery based on the initial quantity of algae utilized in each experiment. Figure IV-7 represents the fraction of oil extracted out of the total quantity of quantity of oil in the initial microalgae for each sample. This fraction was calculated using TCA results from the extracted oil sample compared to TCA results from the original microalgae biomass. The combined mass in the 300°C and 400°C temperature fractions

for the extracted oil was divided by the combined mass in the 300°C and 400°C temperature fractions measured in the microalgae feedstock. Figure IV-4 and Figure IV-6 can be utilized to determine that sonication does not significantly impact the recovery as recovery with all other conditions identical except for with (Figure IV-6) or without (Figure IV-4) sonication for both sets of experiments with methanol and ethanol is approximately the same, 9 and 6 wt% of the initial microalgae mass, respectively. Sonication does appear to improve the recovery with hexane as sonication yields approximately a 3 wt% increase.

Figure IV-6 and Figure IV-10 can be used to compare the two techniques of cell disruption: sonication and microwave. In both figures, lipids were extracted from microalgae using the ratio for microalgae to solvent of 1:10 at 25°C with methanol, ethanol, and hexane. The extraction result is approximately 4% higher for microwave extraction than sonication. Microwave is a more energy intensive technique, however as the operating temperature of the microwave increases the extraction efficiency also increases dramatically.

Sonication is a commonly studied technique to enhance extraction efficiency for microalgae oil. Previous studies have yielded similar results to this current study. All of the experiments in literature completed with *Chlorella Vulgaris* and sonication, were performed at a microalgae-to-solvent ratio of 1:10 or 1:15 (g:mL). Maximum extraction yields from sonication facilitated extraction with *Chlorella Vulgaris* range from 7% to 14%<sup>40, 52, 53</sup> with previous work performed with similar conditions to the experimentation performed in this study. The recovery fraction is assumed to be the fraction extracted from the initial biomass, and therefore directly comparable to the results of the gravimetric

analysis. Extraction with sonication was determined to be less efficient in comparison to microwave facilitated extraction and temperature facilitated extraction.

### *3.5 Temperature Study Results*

The fifth factor analyzed was the effect of temperature for the enhancement of lipid extraction. The temperature study was performed using microalgae pretreated at the optimized grinding conditions and a microalgae-to-solvent ratio which falls in the range determined in the initial ratio study. If temperature alone can mimic the high extraction efficiency provided by microwave, it provides an alternative method to increase extraction efficiency without the energy and capital cost intensive cell disruption techniques of microwave or sonication. We postulated that increasing the extraction temperature within the reactor may provide the energy necessary to facilitate solvent extraction of the lipids comparable to the energy provided by microwave or sonication; eliminating the need for highly energy intensive cell disruption techniques in order to improve the scale up potential of the extraction technique.

The first set of temperature study experiments was completed utilizing a small batch reactor (Figure IV-12). The gravimetric results from the 11 experiments performed in triplicate for the temperature study was used to generate Figure IV-13. This figure is the gravimetric result of the collected liquid from the solvent leaching and is reported as percent recovery based on the initial quantity of algae utilized in each experiment. Figure IV-14 represents the fraction of oil extracted out of the total quantity of oil in the initial microalgae, calculated as described for Figure IV-5. Figure IV-13 and Figure IV-14 can be compared to Figure IV-10 and Figure IV-11 to determine the effect of temperature facilitated extraction in comparison to microwave facilitated extraction. Figure IV-13

indicates that the extraction recovery at 140°C, for methanol, ethanol, and hexane is approximately 15, 10, and 2 wt% of the initial microalgae mass, respectively. Figure IV-10 indicates that the comparable recoveries with microwave are 23 and 15 wt% at 140°C for methanol and ethanol, respectively while the recovery at 110°C with microwave is 7 wt% for hexane. Thus, we can conclude that when extraction is performed within the operating range of the microwave system, using the microwave provides increased lipid extraction with these solvents compared to extraction at the same temperature without the use of microwaves.

However, Figure IV-13 also shows that at 200°C extraction recoveries of 35, 25, and 5 wt% of the initial microalgae biomass were achieved for methanol, ethanol, and hexane, respectively which are higher recoveries than could be obtained using the microwave at its highest allowable temperature. Thus, a greater extraction recovery can be achieved through temperature facilitated extraction when operating at a higher temperature than when using a microwave with the added advantage of a greatly reduced energy requirement.



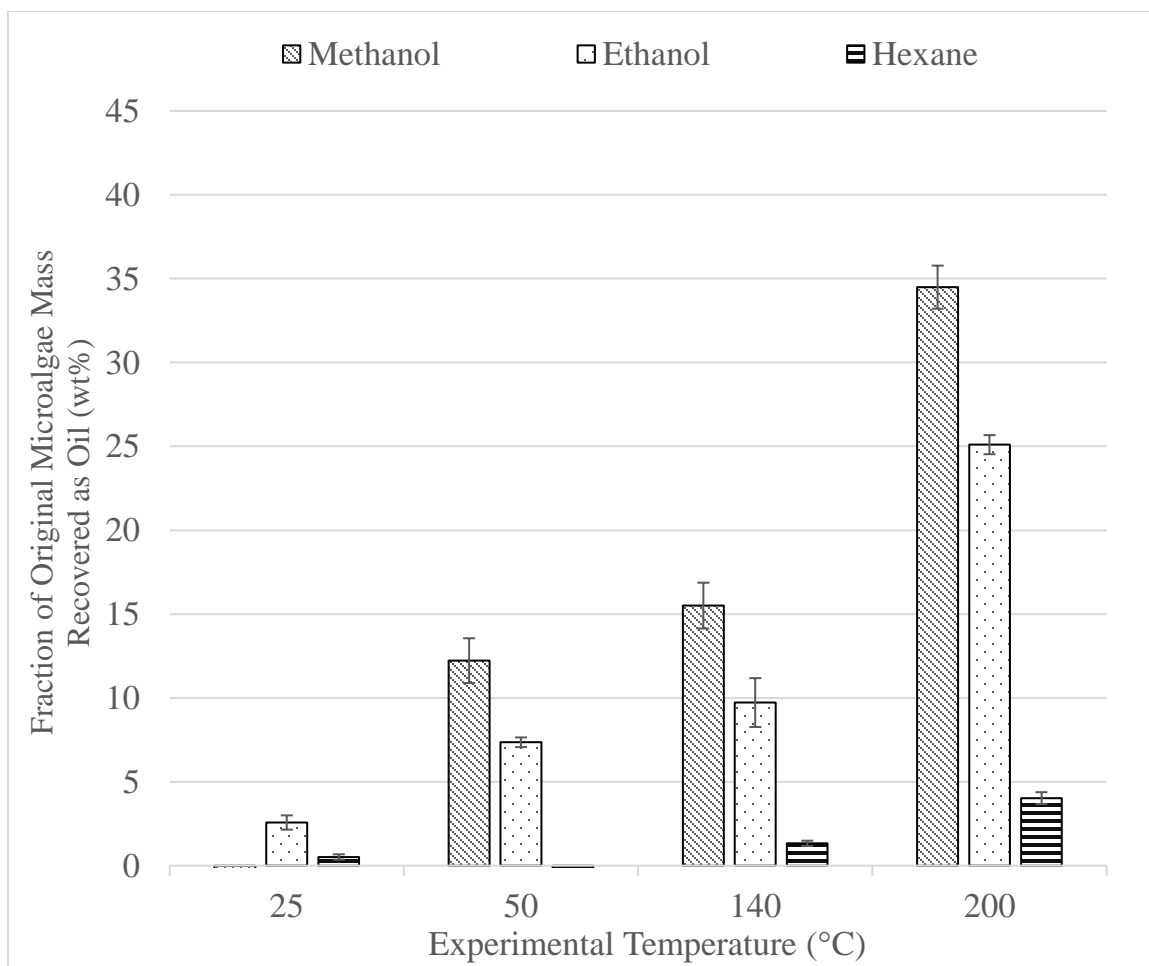

*Figure IV-13:*Effect of temperature facilitated extraction on lipid extraction; gravimetric results

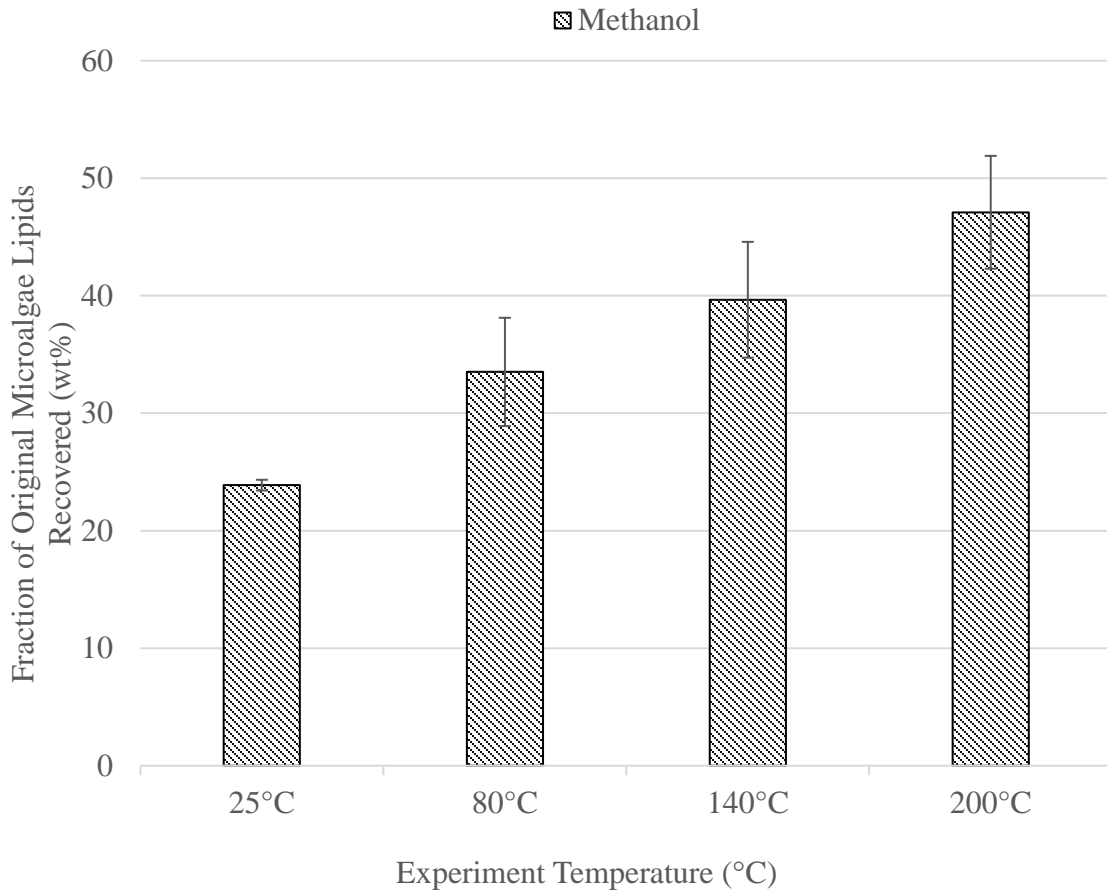
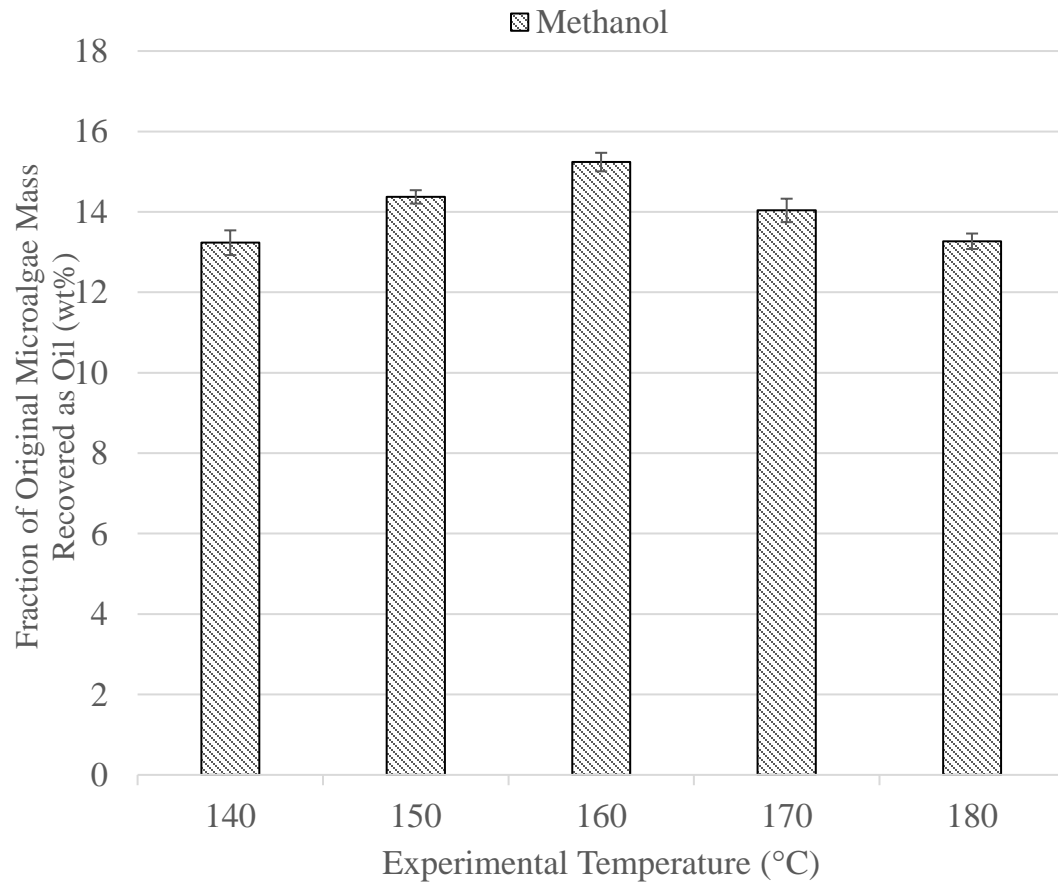

Figure IV-14: Effect of temperature facilitated extraction on lipid extraction; thermal carbon analysis results

The second set of temperature study experiments was completed utilizing a small pressure tube reactor, an oven, and methanol as the only solvent. This set of experiments was to determine the optimum extraction temperature in the range of 140-180°C. The optimum extraction temperature was found before 180°C, therefore experiments up to 200°C were not completed. The gravimetric results from the nine experiments performed in triplicate for the temperature study were used to generate Figure IV-15. This figure is the gravimetrical result of the collected liquid from the solvent leaching and is reported as percent recovery based on the initial quantity of algae utilized in each experiment. Figure

IV-16 represents the fraction of oil extracted in respect to the total quantity of oil in the initial microalgae, calculated as described for figure IV-5. It was determined that extraction efficiency of lipids in microalgae is optimized at 160°C.

Temperature facilitated extraction did not provide extraction efficiencies that matched or exceeded the ability of microwave facilitated extraction. The extraction performed with microwave at 140°C exceeded the extraction performed without microwave at 140°C. However, temperature facilitated extraction was able to be performed above 140°C and under these conditions, the extraction efficiency was comparable to the maximum achieved with the microwave. The increase in extraction when using the microwave is negated by the energy intensity of microwave facilitated extraction.



*Figure IV-15:*Effect of temperature facilitated extraction on lipid extraction; gravimetric

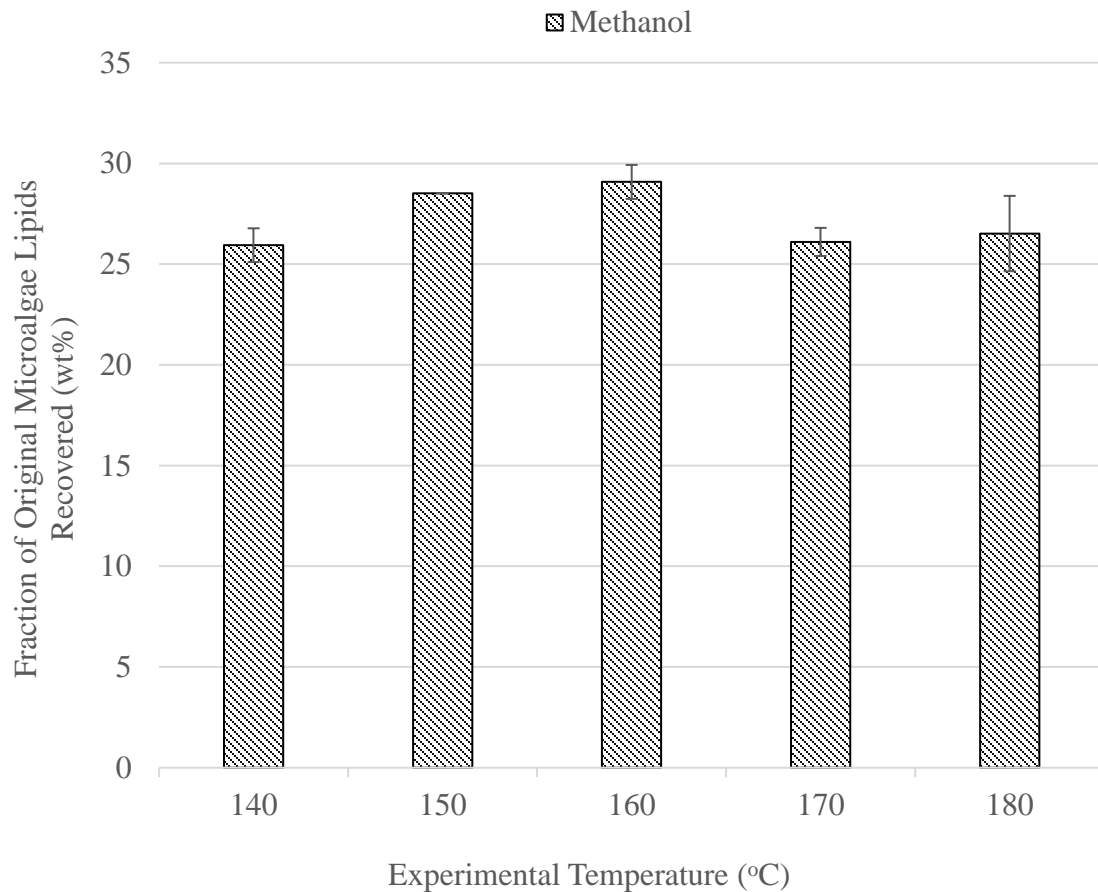

*Figure IV-16: Effect of temperature facilitated extraction on lipid extraction; thermal carbon analysis results*

### *3.6 In Situ Transesterification Study*

The sixth factor analyzed was the effect of in situ transesterification for the enhancement of lipid extraction. Utilizing in-situ transesterification allows the lipids to be transformed to esters during extraction. The transformation is completed using the combination of alcohol and acid, and the extraction is completed with the remaining alcohol.

The in-situ transesterification study includes the optimized grinding conditions for the pre-treatment of microalgae and a microalgae-to-solvent ratio which falls in the range

determined in the initial ratio study. The gravimetric results from the four experiments performed in triplicate for the in-situ transesterification study were used to generate Figure IV-17. This figure is the gravimetric result of the collected liquid from the solvent leaching and is reported as percent recovery based on the initial quantity of algae utilized in each experiment.

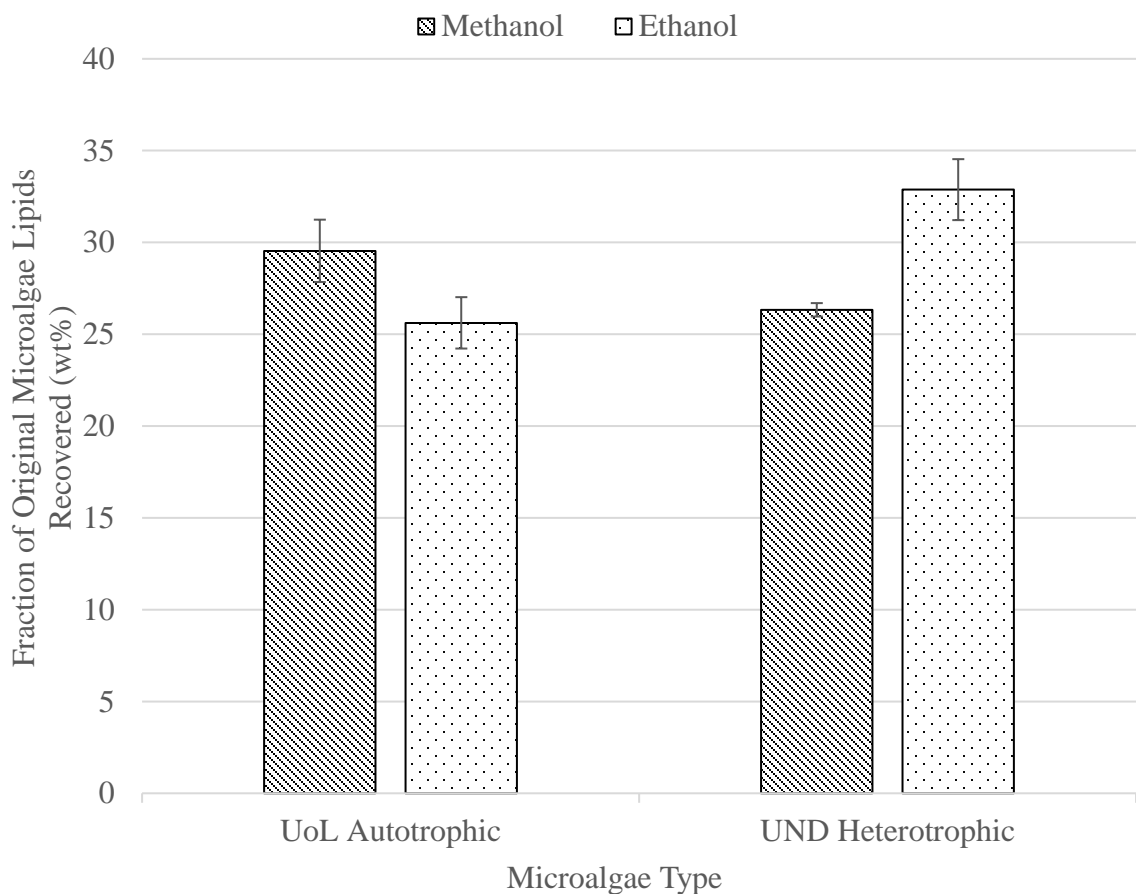
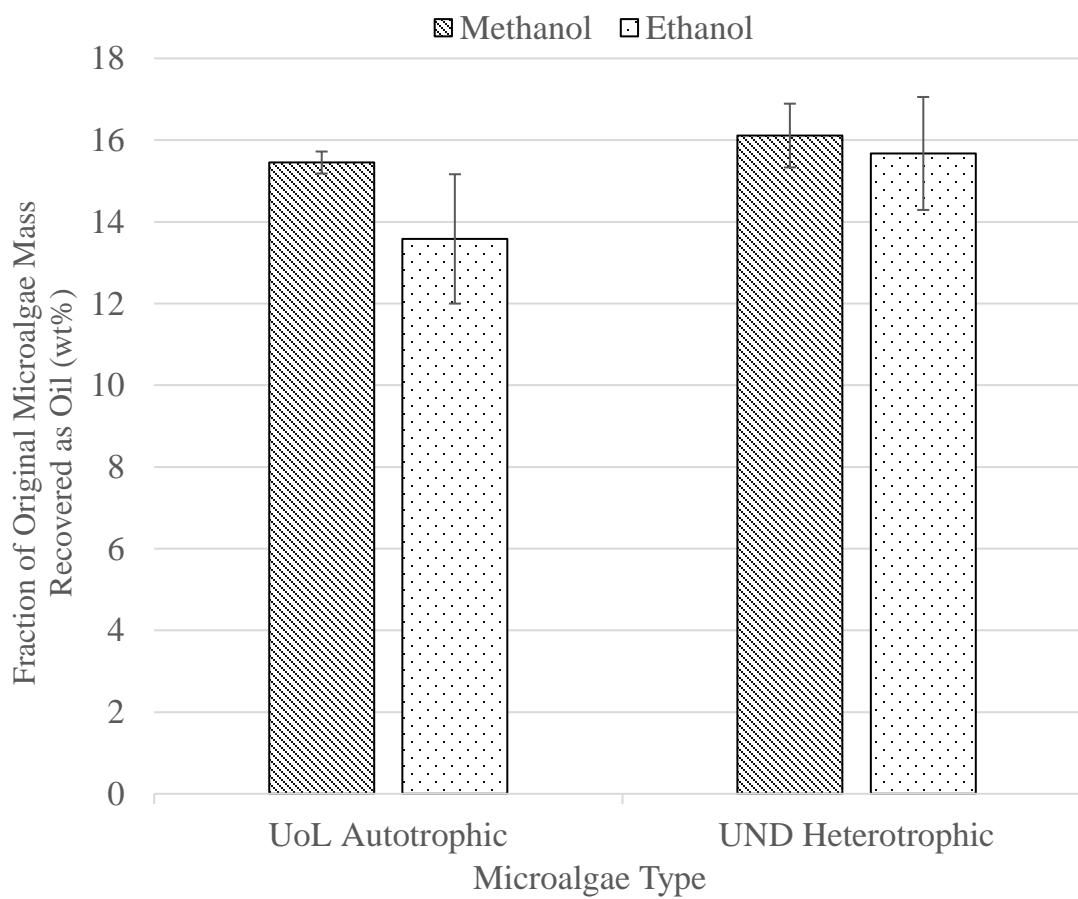
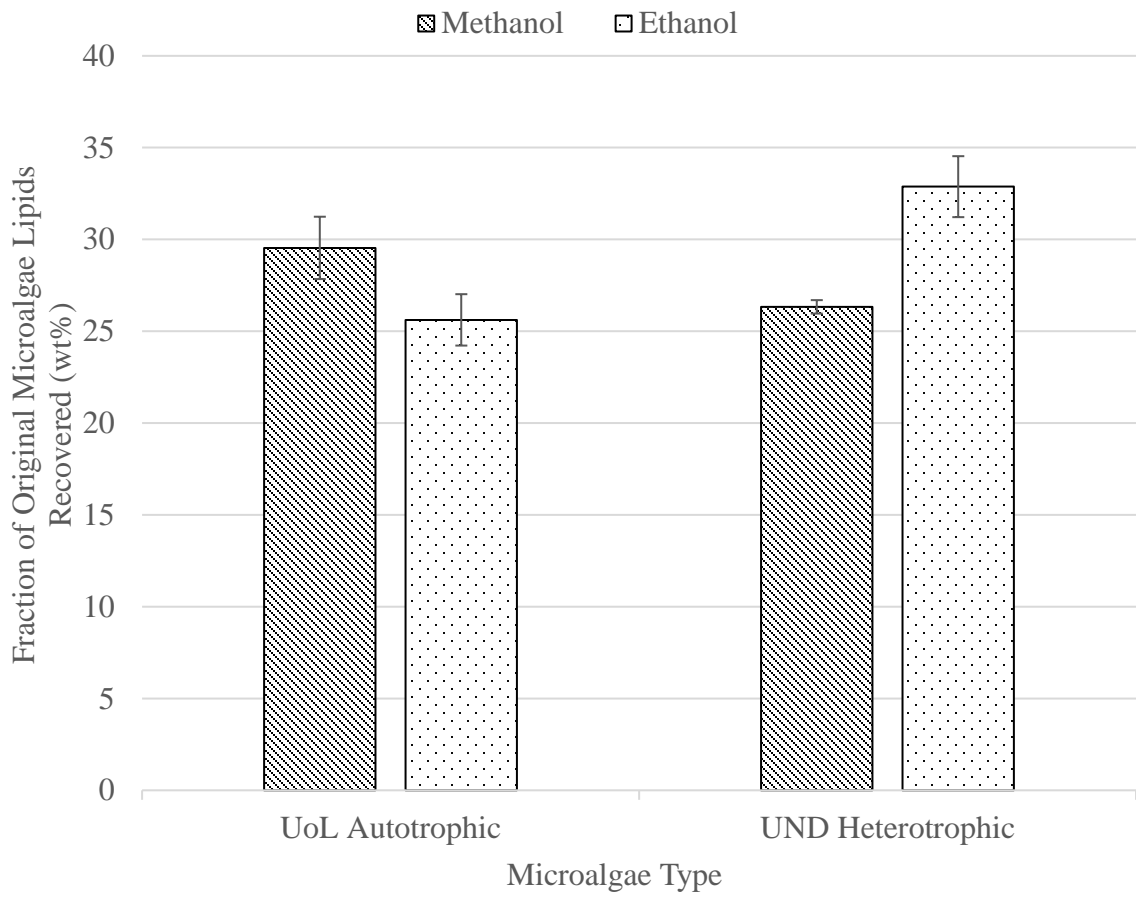

Figure IV-18 represents the fraction of oil extracted with respect to the total quantity of oil in the initial microalgae, calculated as described for Figure IV-5.



*Figure IV-17: Effect of In-situ Transesterification on Lipid Extraction; gravimetric results*



*Figure IV-18:*Effect of In-situ Transesterification on Lipid Extraction; thermal carbon analysis results.

The result of the in-situ transesterification study produced lower yields than experiments to extract the lipids directly, which is consistent to results reported in the literature. To determine how in-situ transesterification facilitated extraction compares to



microwave and temperature, Figure IV-17 and

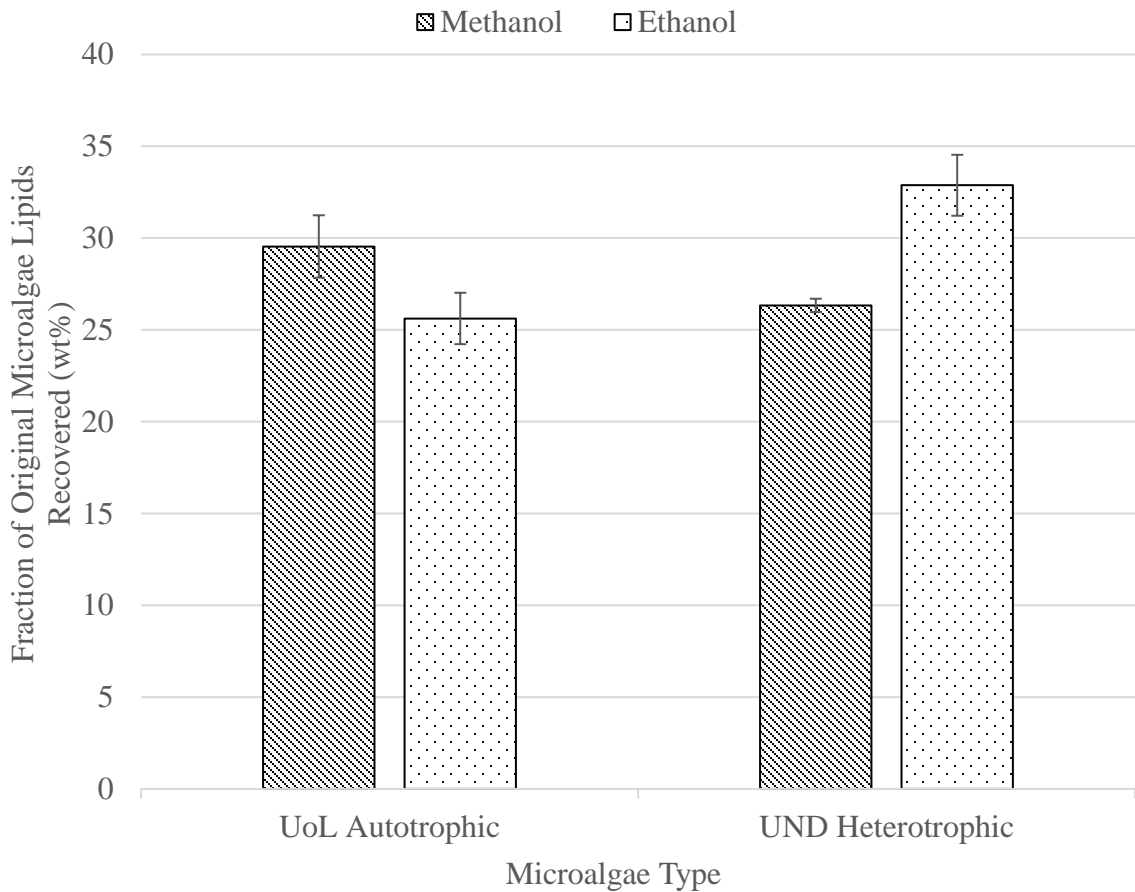

Figure IV-18 should be compared to Figure IV-10 and Figure IV-11 for microwave facilitated extraction and Figure IV-13 and Figure IV-14 for temperature facilitated extraction. The esters recovery for the in-situ transesterification for the autotrophic microalgae was approximately 16 and 14wt% of the total inlet biomass (figure IV-14) for methanol and ethanol compared to lipids recoveries of 24 and 16 wt% for 140° C microwave facilitated extraction (figure IV-8) and 35 and 25 wt% for 160° C temperature facilitated extraction (figure IV-10) for methanol and ethanol, respectively.

It should be noted that the in-situ transesterification facilitated extraction in the present study yielded lower recoveries than was reported by Chamola, et al. Their results,

based on utilizing a reaction temperature of 50°C, 60-minute reaction time, an 1:10 (g:mL) microalgae-to-solvent ratio, and a 1:2.8 (g:mL) microalgae to catalyst ratio, indicate a 90% overall recovery of esters can be achieved for an acid catalyzed reaction and 87% overall recovery for a base catalyzed reaction of free fatty acids to esters and extraction of the esters via in-situ transesterification<sup>54</sup>. However, in a study by Deshmukh et al., that utilized a reaction temperature of 58°C, 90-minute reaction time, an 1:15 (g:mL) microalgae-to-solvent ratio, and a 1:1.5 (g:mL) microalgae to catalyst ratio, a recovery of only 5.4% from the initial biomass<sup>40</sup> was reported, which is lower than the present study. Both of the previous studies utilized a longer reaction time and higher concentration of acid in the experimental mixture in comparison to the current study.

### *3.7 Optimization Study Results*

The final set of experiments were performed at the optimum microalgae oil extraction conditions from the previous experiments in order to compare the efficiency when applied to three feedstocks: the autotrophic *Chlorella Vulgaris* obtained from the University of Leeds, the autotrophic *Chlorella Vulgaris* grown at the University of North Dakota, and the heterotrophic *Chlorella Vulgaris* grown at the University of North Dakota. The three experiments, all completed in triplicate, were performed with the following optimized conditions: methanol as the solvent, 500 rpm grinding speed, 1:9 microalgae to solvent ratio, and at an extraction temperature of 160°C. The gravimetric results from the three experiments performed in triplicate for the microwave study are shown in Figure IV-19 (the liquid collected after solvent leaching reported as the mass fraction of the initial algae recovered) and Figure IV-20 (the fraction of the original lipids extracted for each sample, calculated as described for Figure IV-7). Utilizing the optimized conditions, 14%,

15%, and 45% was extracted and determined to be lipids from the initial microalgae mass. This quantity represents 30%, 35%, and 94% of the total quantity of lipids that could be extracted from the initial microalgae mass.

The gravimetric and thermal carbon analysis results yielded a higher total oil content in the heterotrophic microalgae in comparison to both the autotrophic microalgae obtained from the University of Leeds, as well as the autotrophic microalgae grown at the University of North Dakota. The total oil content in the heterotrophic microalgae was determined to be 26%. The gravimetric oil recovery of the heterotrophic strain yielded a much higher result in comparison to the 26%. This may be due to other impurities in the extraction liquid. However, the thermal carbon analysis did indicate over 94% of the total oil which existed in the heterotrophic strain of *Chlorella Vulgaris* was extracted. In comparison, a typical soybean oil extraction with hexane, operating in the range of 1:5 to 1:10 feed-to-solvent extraction ratio and yields 20% oil with 99% of the total quantity of oil being extracted<sup>55</sup>. At present, we cannot explain the unusually high extraction efficiency from the heterotrophic strain and future study is recommended.

Table 2 shows a comparison between the highest extraction yield both by percent mass of total initial microalgae and by percent mass of initial oil in the microalgae from the optimization of each factor in comparison to the final optimization extraction method. These results indicated that microwave facilitated extraction may provide the highest initial mass extraction and the highest percent yield of initial oil. However, similar results can be obtained simply by extraction at a slightly higher temperature (160 °C without microwave compared to 140 °C with microwave). Thus, the increase in extraction when using the

microwave is negated by the energy and capital cost intensity of microwave facilitated extraction.

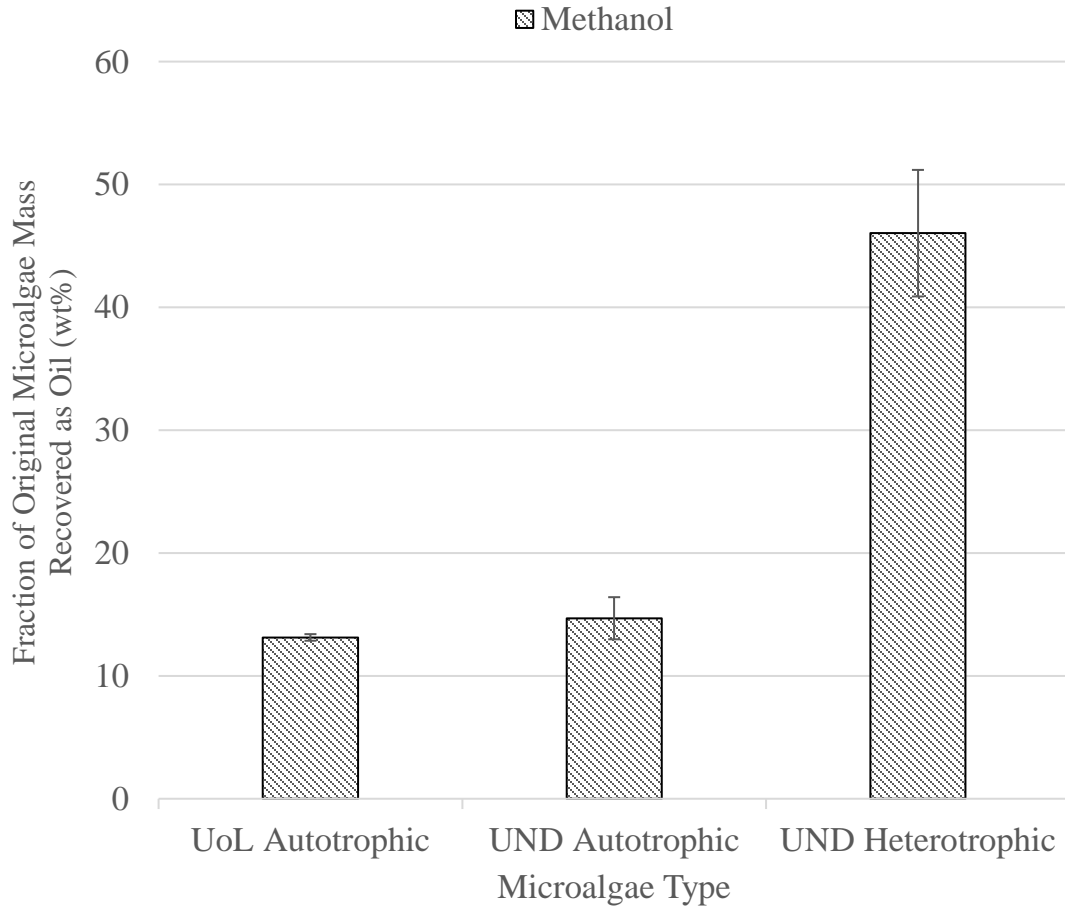
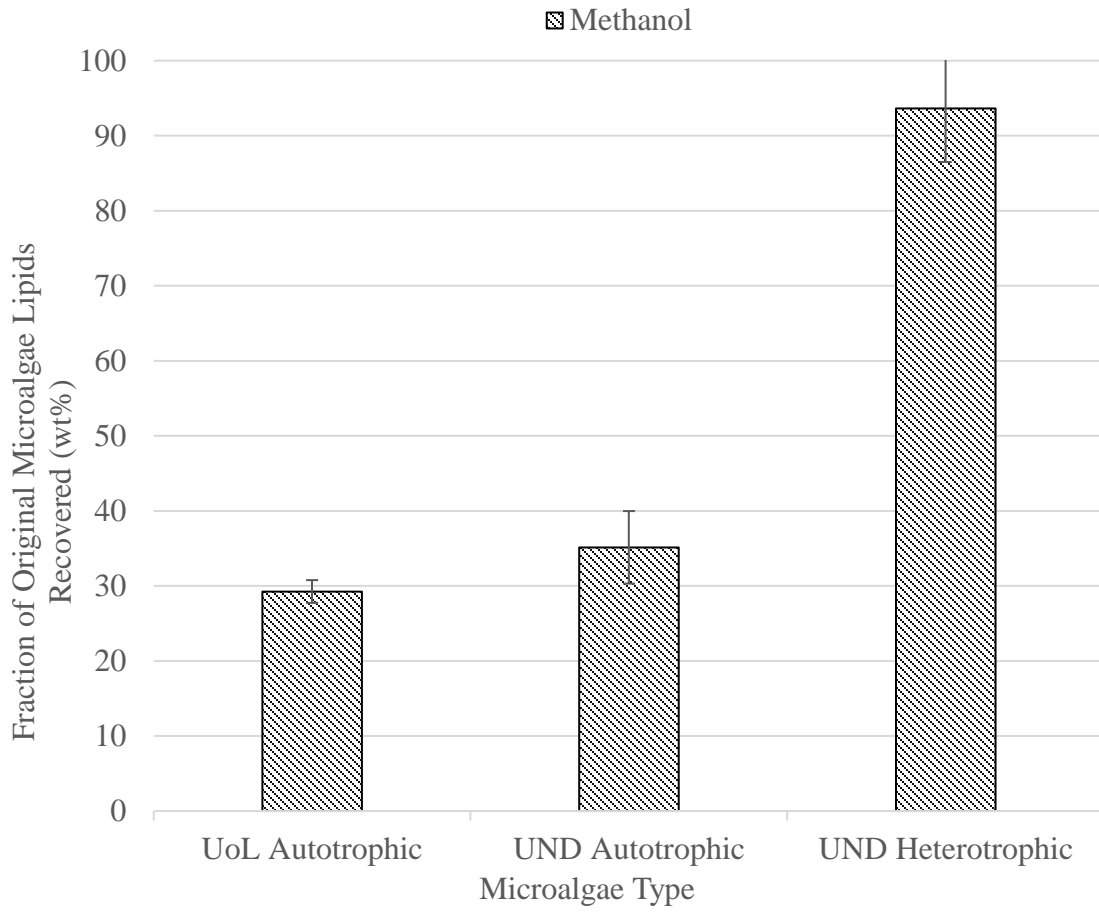

Figure IV-19: Effect of optimized conditions gravimetric results



*Figure IV-20: Effect of optimized conditions thermal carbon analysis results*

*Table IV-2: Summary Comparison of Extraction Experiment Results with the Optimum Solvent, Methanol*

<b>Extraction Study</b>	<b>Fraction of Initial Microalgae Mass Recovered as Lipids (wt%)</b>	<b>Fraction of Initial Lipids in the Microalgae Recovered as Lipids (wt%)</b>
<b>Grinding</b>	9	-
<b>Microalgae to Solvent</b>	9	24
<b>Microwave</b>	24	55
<b>Sonication</b>	9	14
<b>Temperature</b>	16	30
<b>In situ transesterification</b>	16	30
<b>Optimized UoL Autotrophic</b>	14	30
<b>Optimized UND Autotrophic</b>	15	35
<b>UND Heterotrophic at Optimized Autotrophic Conditions (preliminary)</b>	45	94

#### *4. Conclusions*

- This study successfully determined optimum extraction conditions for microalgae oil by analyzing the following factors: solvent choice, mechanical pre-treatment, microalgae to solvent ratios, microwave facilitated extraction; sonication facilitated extraction; temperature facilitated extraction; and in-situ transesterification facilitated extraction.
- The optimized extraction conditions were determined to be utilizing methanol as the solvent, with a grinding speed of 500 rpm, a 1:9 microalgae to solvent ratio, and in at an extraction temperature of 160°C.
- The optimized extraction experiments yielded 14%, 15%, and 45% lipids from the initial microalgae mass from the UoL autotrophic microalgae, UND autotrophic microalgae, and UND heterotrophic microalgae respectively.

- Additionally, the optimized extraction experiments yielded 30%, 35%, and 94% lipids from the initial oil mass contained in the microalgae from the UoL autotrophic microalgae, UND autotrophic microalgae, and UND heterotrophic microalgae, respectively.

### *5. Acknowledgments*

The authors would like to thank the following for their contributions to this work: Edward Kolodka, Yun Ji, Ian Foerster, and Maram Al-Sayaghi. Financial support was provided by the National Science Foundation IRES Program [grant number 1458962]. Any opinions, findings, and conclusions or recommendations expressed in this material are those of the author(s) and do not necessarily reflect the views of the National Science Foundation.

## CHAPTER V. CONCLUSIONS



### *Study Objectives*

#### Chapter II:

1. To determine if a process for the growth and extraction of lipids from the heterotrophic microalgae strain of *Chlorella Vulgaris* would be more economically attractive than a process based on the autotrophic version of the same microalgae.

#### Chapter III:

1. To grow, transition, and compare the autotrophic strain of *Chlorella Vulgaris* to the heterotrophic strain of *Chlorella Vulgaris*, as well as to analyze the effect of various organic carbon concentrations in the Heterotrophic Basal Media (HBM) utilized for growth of the heterotrophic microalgae.
2. To identify the optimum concentration range of organic carbon in the growth media to produce the largest quantity of lipids.

#### Chapter IV:

1. To optimize the extraction of lipids from the strain of microalgae *Chlorella Vulgaris*.
2. To compare the extraction efficiency from both autotrophic and heterotrophic *Chlorella Vulgaris*.

### *Conclusions*

#### Chapter II:

1. Using the heterotrophic strain was more cost effective than the autotrophic strain, although currently, neither the heterotrophic nor autotrophic process designs are economically feasible.
2. The innovation of heterotrophic microalgae has driven microalgae closer to economic viability, however additional research and development is required to improve the growth phase and the solvent extraction efficiency.

### Chapter III:

1. *Chlorella Vulgaris* was successfully grown autotrophically, transitioned to heterotrophic conditions under controlled conditions allowing comparisons between the two end product strains.
2. The effect of various organic carbon concentrations in the Heterotrophic Basal Media (HBM) on heterotrophic algae growth and lipid concentration was analyzed and the optimum concentration was determined to be near 60 g/L.
3. Analyses indicate an increased lipids content in the heterotrophic microalgae when directly compared to autotrophic microalgae.

### Chapter IV:

1. The optimized extraction conditions were determined to be: utilizing methanol as the solvent, a grinding speed of 500 rpm, a 1:9 microalgae to solvent ratio (g/mL), and an extraction temperature of 160°C with no microwave, sonication, or tranesterification.
2. The optimized extraction experiments yielded 13, 14, and 44 wt% lipids from the initial microalgae mass from the UoL autotrophic microalgae, UND autotrophic microalgae, and UND heterotrophic microalgae, respectively.
3. The optimized extraction experiments yielded 30, 35, and 94 wt% lipids from the initial oil mass contained in the microalgae from the UoL autotrophic microalgae, UND autotrophic microalgae, and UND heterotrophic microalgae, respectively. However, future verification should be made of the heterotrophic results as we cannot currently explain why the efficiency is so much higher than from autotrophic strains.

### *Recommendations*

### Chapter II:

Several recommendations to improve the economic feasibility of this technology can be concluded from the design. The two areas which appear to have the most room for improvement are the growth phase and the fatty acid solvent extraction phase. During the heterotrophic microalgae growth phase, the media requires a large quantity of chemicals and an organic carbon for production. If an alternative growth media which already contained some of the nutrients was identified and/or if an alternative organic carbon source, such as a wastewater stream routed from another industrial process, were utilized, the cost of growing the microalgae would decrease greatly. Additionally, the cell density of the microalgae during in the growth media is very low, resulting in a large water requirement. The large water requirement causes the dewatering of the microalgae to be energy intensive. If a method of increasing cell density during growth was developed, the cost of the growth phase would decrease.

The fatty acid solvent extraction requires a low ratio of microalgae to solvent to efficiently extract the oils. The large quantity of solvent is cost prohibitive to use and recover from the low quantity of oils extracted. The total oils in the methanol after extraction is approximately 3.9 wt%. This low concentration results in the selection of a multi-effect evaporator to most efficiently separate the two miscible liquids. If a more efficient solvent extraction step were developed, the cost of the solvent recovery would decrease, and the separation step would be simplified, pushing the economics of the process towards profitability. Further, adding a less energy intensive preconcentration step for the oils-in-methanol solution, such as a pervaporation membrane may also further reduce costs.

Chapter III:

Two recommendations for future work can be concluded from the study focused on the growth, transition, and comparing autotrophic and heterotrophic *Chlorella Vulgaris*. The first recommendation is to perform a study to optimize the concentration of organic carbon in the HBM. Growth at organic loadings above 80 g/L should be performed to bound the optimum growth achievable. Then, additional studies should be performed over a narrower range, perhaps between 40 g/L and 80 g/L where the optimum concentration may occur. A cost benefit analysis should be used to inform this study.

The second recommendation would be to perform additional analysis, such as thermal desorption pyrolysis gas chromatography mass spectroscopy (TD-Py-GC-MS), during growth and cultivation of the *Chlorella Vulgaris* to better understand and identify the optimum growing conditions. This analysis would yield a better understand of the composition of the lipids throughout the growth cycle in respect to organic carbon concentration in the HBM.

#### Chapter IV:

Two recommendations can be concluded from the study focused on extraction efficiency optimization for future work. The first recommendation is to perform TD-Py-GC-MS analysis on the extracted oil from both the autotrophic and heterotrophic microalgae for enhanced characterize the extraction product. The second recommendation is to further study the optimization of lipid extraction from the heterotrophic strain of *Chlorella Vulgaris* to ensure the optimized conditions determined for the autotrophic microalgae are consistent with the optimized conditions for heterotrophic microalgae.

APPENDIX A: CHAPTER 1 HETEROTROPHIC PROCESS  
DETAILED PROCESS DESCRIPTION

### *A.1 Detailed Process Description: Heterotrophic Process*

Process flow diagrams (PFD) detail the unit operations necessary for microalgae oil extraction. Area 01- Growth and Cultivation, Filtration, and Crushing is reported in Drawing 01-A-003. Area 02- Extraction and Lipid Separation is reported in Drawing 02-A-003. These PFDs include mass balances for each unit operation, process temperature profiles, and process pressure profiles.

The major equipment list is reported in Table 6 and details the specifications for each unit operation included in the PFDs. Appendix E reports the simulation data used to size the multi-effect evaporator and necessary surrounding minor equipment. Appendix D reports the sample calculations used to size equipment.

#### *Area 01: Growth, Cultivation, Filtration, and Crushing*

The initial microalgae seed is grown in a lab. The lab growth will yield 0.19 lb of microalgae in 9.5 lb of water which is manually transferred to R-101 A-C to initiate growth in the reactor.

The first process area starts with the reactors R-101 A-C on Drawings 01-A-003 and Drawing 01-A-004. Reactors R-101 A-C operate as a semi-batch process with the following steps: fill the reactors, grow microalgae, transfer microalgae, and sterilize the reactors. The following description is for a single reactor (R-101 A) out of three (R-101 AC). R-101 A (Sheet 01-A-004/01) is already filled with 6.3 lb of sterile air. In the first step, 4,700 lb of water is pumped into R-101 A through stream 6, at 2,400 lb/hr, until the level reaches the water set point. The sterile air is vented through stream 61 to the atmosphere to maintain 100 kPa. In step 2, 220 lb of HBM is added to R-101 through stream 3 at 110 lb/hr until the level reaches the media set point. Sterile air is vented through

stream 61 to maintain 100 kPa. In step 3, 0.19 lb microalgae in 9.5 lb water is manually transferred from the lab to R-101 A through stream 7. Sterile air is vented through stream 61 to maintain 100 kPa.

In step 4 (Sheet 01-A-004/02), sterile air is bubbled into R-101 A via stream 10 at 0.044 lb/hr, until the microalgae density reaches the target microalgae density at approximately 15 days. The sterile air agitates the microalgae and provides oxygen for cellular respiration. Excess air and carbon dioxide produced by the microalgae is vented through stream 61 to maintain 100 kPa. The nutrients present in the HBM are consumed by the microalgae. In step 5, 94 lb of microalgae in 4,700 lb of water is pumped by L-101 A/B from R-101 A to the next set of reactors, through stream 8 at 9,600 lb/hr. During the transfer, 6.3 lb of sterile air is added from stream 10 into R-101 A to maintain 100 kPa. Step 5 ends when the liquid level reaches the minimum level set point. In step 6, 11 lb of low-pressure steam is added to R-101 A through stream 65. Sterile air is vented through stream 61 to maintain 450 kPa until the pressure reaches the pressure set point.

In step 7 (Sheet 01-A-004/03), the low pressure steam is held in R-101 A for 20 minutes, and ends when the time reaches the time set point. Holding the steam sterilizes the reactor of pathogens and remaining microalgae. In step 8, cooling water enters the R-101 A cooling jacket from stream 87 and exits through stream 67. The cooling jacket condenses the low pressure steam. The steam condensate and wastes are transferred out R-101 A through stream 68, and pumped to waste treatment by L-201 A/B. Sterile air is added from stream 10 to R-101 A to help transfer the steam condensates and wastes, and maintain pressure at 100 kPa. Step 8 ends when all the steam is condensed, the condensate is out of the reactor, and the temperature reaches the temperature set point.

Reactors R-101 A-C (Sheet 01-A-004/04) operate on a staggered 15 day cycle. R-101 A starts step 1 on day 1, R-101 B starts step 1 on day 6, and R-101 C starts step 1 on day 11. In the 15 day cycle steps 1-3 and 5-8 are approximately 8 hours total. Step four, the growth step, accounts for 98% of the total cycle time.

After R-101 A-C are reactors R-102 A-D on Drawings 01-A-003 and 01-A-005. Reactors R-102 A-D operate in a semi-batch process with the following steps: fill the reactors, grow microalgae, transfer microalgae, and sterilize the reactors. The following description is for a single reactor (R-102 A) out of four (R-102 A-D).

R-102 A (Sheet 01-A-005/01) is already filled with 3,100 lb of sterile air. In the first step, 2,400,000 lb of water is pumped into R-102 A through stream 5, at 790,000 lb/hr until the water reaches the water set point. The sterile air is vented through stream 93 to the atmosphere to maintain 100 kPa. In step 10, 110,000 lb of HBM is added to R-102 A through stream 2 at 37,000 lb/hr until the level reaches the media level set point. Sterile air is vented through stream 93 to maintain 100 kPa. In step 11, 94 lb microalgae in 4,700 lb water is pumped from the R-101 A-C to R-102 A through stream 8 until the level reaches the microalgae level set point. Sterile air is vented through stream 93 to maintain 100 kPa. In step 12 (Sheet 01-A-005/02), sterile air is bubbled into R-102 A via stream 11 for 15 days at 23 lb/hr, until the microalgae reaches the target microalgae density at approximately 15 days. The sterile air agitates the microalgae and provides oxygen for cellular respiration. Excess air and carbon dioxide produced by the microalgae is vented through stream 93 to maintain 100 kPa. The nutrients present in the HBM are consumed by the microalgae. In step 13, 47,000 lb of microalgae in 2,400,000 lb of water is pumped by L-102 A/B from R-102 A to the vacuum filter, through stream 12 at 20,000 lb/hr. The transfer feeds the



vacuum filter for 5 days, and ends when the level reaches the level set point. A total of 3,200 lb of sterile air is added from stream 10 into R-102 A to maintain 100 kPa. In step 14, 5,800 lb of low pressure steam is added to R-102 A through stream 95 until the pressure reaches the pressure set point. Sterile air is vented through stream 93 to maintain 450 kPa. In step 15 (Sheet 01-A-005/03), the low pressure steam is held in R-102 A for 20 minutes, and ends when the time reaches the time set point. Holding the steam sterilizes the reactor of pathogens and remaining microalgae. In step 16, cooling water enters the R-102 A cooling jacket from stream 98 and exits through stream 99. The cooling jacket condenses the low pressure steam. The steam condensate and wastes are transferred out R-102 A through stream 100, and pumped to waste treatment by L-102 A/B. Sterile air is added from stream 11 to R-102 A to help transfer the steam condensates and wastes, and maintain pressure at 100 kPa. Step 16 ends when all the steam is condensed, the condensate is transferred from the reactor, and the temperature reaches the temperature set point. Reactors R-102 A-D (Sheet 01-A-005/04) operate on a staggered 20 day cycle. R-102 A starts step 9 on day 1, R-102 B starts step 9 on day 6, R-102 C starts step 9 on day 11, and R-101 D starts step 9 on day 16. In the 20 day cycle, steps 9-11 and 14-16 are approximately 10 hours total. Step 12, the growth step, is 15 days and accounts for 73% of the total cycle time. Step 13, the draining step, is 5 days and accounts for 25% of the total cycle time.

Stream 12 contains primarily water, with small amounts of biomass, lipids, and HBM. Stream 12 enters the vacuum filter (H-101 A/B) as shown on Sheet 01-A-003/02 at a flow rate of 20,000 lb/hr. H-101 A/B separates out most of the water at a rate of 20,000 lb/hr as stream 13. Microalgae sludge leaves H-101 A/B as stream 14, and containing 18% water by weight. The sludge is transported via a conveyor (J-101 A/B) to a filter press (H-

102 A/B). 21% of the remaining water in the sludge is filtered out and leaves H-102 A/B as stream 15 at a rate of 19 lb/hr.

Stream 13 is pressurized to 120 kPa using L-103 A/B to prevent backflow into stream 15. These two streams become stream 16 which is sent through a feed pump (L-104 A/B) to increase the pressure from 97 kPa to 240 kPa. The water is heated to 120 °C in E-101 A/B with 3,000 lb/hr of low pressure steam. Heating stream 16 sterilizes the water and allows the water to be recycled back into the growth tanks R-101 A-C, R-102 A-D. The sterilized water leaves E-101 A/B through stream 55 and is cooled back down by E-106 A/B. E-106 A/B vaporizes 3100 lb/hr of water to cool the sterilized water from 120 °C to 25 °C. The sterilized water leaves E-106 A/B from stream 56 and enters T-101.

T-101 (Sheet 01-A-003/03) is a water accumulation tank that operates in semi batch (01-A-006). In steps 17 and 19, sterilized water containing 46 lb/hr HBM continuously enters T-101 at 20,000 lb/hr. Makeup water is continuously added through stream 59 to account for water loss through the methanol extraction and biomass separation. The design assumes a 5% overall water loss from the process, or about 1,000 lb/hr. In step 18, when R-101 AC are filled with water, T-101 is emptied from stream 4 at 4,500 lb/hr. In step 20, when R102 A-D are filled with water, T-101 is emptied from stream 4 at 2,300,000 lb/hr.

The dried microalgae exits H-102 A/B as stream 20 which contains 15% water by weight as well as biomass, lipids, and small amounts of HBM. The dried algae is transported to the grinder (C-101) by a conveyor (J-102 A/B). Within C-101, the cell walls of the microalgae are broken down to improve the lipid extraction. The crushed microalgae exits C-101 as stream 21 and is transported to the next process area with a conveyor (J-103 A/B) at a rate of 470 lb/hr.

## *Area 02: Extraction and Lipid Separation*

Stream 21, from J-103 A/B, enters Area 02, detailed in Drawing 02-A-003. A screw feeder (J-104 A/B) feeds the microalgae into the leacher (D-101) where methanol is utilized as the solvent for extraction of the lipids from the biomass. Entrained water from the filter press (H-102) is present in the leacher (D-101) at the rate of 71 lb/hr in stream 21. The methanol is fed into the process at D-101 at a rate of 3,100 lb/hr as stream 24. The entrained water is completely absorbed into the methanol fraction. Upon extraction of the lipids, the methanol-lipid mixture with entrained water is routed to the multi-effect evaporator (Sheet 02-A-003/02) as stream 25 at a rate of 3,300 lb/hr. The microalgae biomass with entrained methanol, which contains trace amounts of water, leaves D-101 as stream 26, at a rate of 280 lb/hr to be sold as high protein animal feed by-product.

Stream 25 first enters a pump (L-119), reported in Sheet 02-A-003/06 to adequately pressurize the stream to be able to travel through a cross-exchanger (E-103) and enter effect 1 (V-101). Stream 25 is routed to a cross exchanger (E-103) to pre-heat the evaporator feed stream to minimize the amount of low pressure steam required for effect 1 of the multistage evaporator. Stream 25 is being heated utilizing the top product (stream 45) of effect 7 containing 410 lb/hr of vaporized methanol. Stream 25 partially condenses stream 45, while stream 25 approaches the vaporization temperature.

Stream 25 is routed to effect 1 of the multi-effect evaporator, which is reported in Sheet 02-A-003/02. Stream 25 enters effect 1 at a pressure of 100 kPa and a temperature of 63 °C, and the operating pressure of effect 1 is 97 kPa. 220 lb/hr of low pressure steam vaporizes 450 lb/hr of methanol with trace amounts of entrained lipids and water. The 450 lb/hr of methanol exits V-101 as a vapor through stream 28 at 64 °C and 97 kPa. The

remainder of stream 25 exits V-101 as a liquid through stream 29 at 64 °C and 110 kPa. Stream 29 is routed through a pump (L-106) to pressurize the stream to 140 kPa in order to be routed to the entry point of effect 2.

Stream 28 is routed to effect 2 (V-102) to utilize the latent heat of the stream as the heating agent for the vaporization of methanol in V-102. A pressure drop of 14 kPa occurs across the effect and the stream is completely condensed, exiting V-102 at 59 °C and 83 kPa. In order to avoid the vaporization in the methanol recycle stream, stream 28 is sub-cooled in E-102 using 130 lb/hr of process cooling water. The process cooling water (stream 30) enters E-102 at 30 °C and 210 kPa and exits E-102 at 45 °C and 170 kPa. Stream 28 exits E102 at 69 kPa, due to the 14 kPa pressure drop, and 52 °C.

Stream 29 is routed to effect 2 (V-102) to vaporize additional methanol to continue to concentrate the feed stream. Stream 29 enters effect 2 at a pressure of 140 kPa and a temperature of 64 °C, and the operating pressure of effect 2 is 83 kPa. 450 lb/hr of methanol with trace amounts of entrained lipids and water are vaporized by utilizing the flash effect of the pressure drop in the system and by utilizing the latent heat of stream 28. The 450 lb/hr of methanol exits V-102 as a vapor through stream 31 at 60 °C and 83 kPa. The remainder of stream 29 exits V-102 as a liquid through stream 32 at 60 °C and 97 kPa. Stream 32 is routed through a pump (L-107) to pressurize the stream to 130 kPa in order to be routed to the entry point of effect 3.

Stream 31 is routed to effect 3 (V-103) to utilize the latent heat of the stream as the heating agent for the vaporization of methanol in V-103. A pressure drop of 14 kPa occurs across the effect and the stream is completely condensed, exiting V-103 at 55 °C and 69 kPa. Stream 31 is routed to L-108 to pressurize the stream to 76 kPa before being combined

with stream 28 as the methanol recycle stream. Stream 31 requires pressurization to overcome the pressure of stream 28 and to prevent backflow. Stream 31 is added to stream 28 and they become stream 35. Stream 35 is a liquid phase stream at 42 °C and 69 kPa. Stream 32 is routed to effect 3 (V-103) to vaporize additional methanol to continue to concentrate the feed stream. Stream 32 enters effect 3 at a pressure of 130 kPa and a temperature of 60 °C, and the operating pressure of effect 3 is 69 kPa. 440 lb/hr of methanol with trace amounts of entrained lipids and water are vaporized by utilizing the flash effect of the pressure drop in the system and by utilizing the latent heat of stream 31. The 440 lb/hr of methanol exits V-103 as a vapor through stream 33 at 56 °C and 69 kPa. The remainder of stream 32 exits V-103 as a liquid through stream 34 at 56 °C and 83 kPa. Stream 34 is routed through a pump (L-109) to pressurize the stream to 120 kPa in order to be routed to the entry point of effect 4.

Stream 33 is routed to effect 4 (V-104) to utilize the latent heat of the stream as the heating agent for the vaporization of methanol in V-104. A pressure drop of 14 kPa occurs across the effect and the stream is completely condensed, exiting V-104 at 50 °C and 69 kPa. Stream 33 is routed to L-110 to pressurize the stream to 76 kPa before being combined with stream 35 as the methanol recycle stream. Stream 33 requires pressurization to overcome the pressure of stream 35 and to prevent backflow. Stream 33 is added to stream 35 and they become stream 36. Stream 36 is a liquid phase stream at 45 °C and 69 kPa. Stream 34 is routed to effect 4 (V-104) to vaporize additional methanol to continue to concentrate the feed stream. Stream 34 enters effect 4 at a pressure of 120 kPa and a temperature of 56 °C, and the operating pressure of effect 4 is 55 kPa. 440 lb/hr of methanol with trace amounts of entrained lipids and water are vaporized by utilizing flash effect of

the pressure drop in the system and by utilizing the latent heat of stream 33. The 440 lb/hr of methanol exits V-104 as a vapor through stream 38 at 51 °C and 55 kPa. The remainder of stream 34 exits V-104 as a liquid through stream 37 at 51 °C and 69 kPa. Stream 37 is routed through a pump (L-111) to pressurize the stream to 100 kPa in order to be routed to the entry point of effect 5.

Stream 38 is routed to effect 5 (V-105) to utilize the latent heat of the stream as the heating agent for the vaporization of methanol in V-105. A pressure drop of 14 kPa occurs across the effect and the stream is completely condensed, exiting V-105 at 43 °C and 55 kPa. Stream 38 is routed to L-112 to pressurize the stream to 76 kPa before being combined with stream 36 as the methanol recycle stream. Stream 38 requires pressurization to overcome the pressure of stream 36 and to prevent backflow. Stream 38 is added to stream 36 and they become stream 39. Stream 39 is a liquid phase stream at 45 °C and 69 kPa.

Stream 37 is routed to effect 5 (V-105) to vaporize additional methanol to continue to concentrate the feed stream. Stream 37 enters effect 5 at a pressure of 55 kPa and a temperature of 51 °C, and the operating pressure of effect 5 is 41 kPa. 430 lb/hr of methanol with trace amounts of entrained lipids and water are vaporized by utilizing the flash effect of the pressure drop in the system and by utilizing the latent heat of stream 38. The 430 lb/hr of methanol exits V-105 as a vapor through stream 41 at 44 °C and 41 kPa. The remainder of stream 37 exits V-105 as a liquid through stream 40 at 44 °C and 55 kPa. Stream 40 is routed through a pump (L-113) to pressurize the stream to 90 kPa in order to be routed to the entry point of effect 6.

Stream 41 is routed to effect 6 (V-106) to utilize the latent heat of the stream as the heating agent for the vaporization of methanol in V-106. A pressure drop of 14 kPa occurs

across the effect and the stream is completely condensed, exiting V-106 at 35 °C and 28 kPa. Stream 41 is routed to L-114 to pressurize the stream to 83 kPa before being combined with stream 39 as the methanol recycle stream. Stream 41 requires pressurization to overcome the pressure of stream 39 and to prevent backflow. Stream 41 is added to stream 39 and they become stream 42. Stream 42 is a liquid phase stream at 43 °C and 69 kPa. Stream 40 is routed to effect 6 (V-106) to vaporize additional methanol to continue to concentrate the feed stream. Stream 40 enters effect 6 at a pressure of 90 kPa and a temperature of 44 °C, and the operating pressure of effect 6 is 28 kPa. 430 lb/hr of methanol with trace amounts of entrained lipids and water are vaporized by utilizing the flash effect of the pressure drop in the system and by utilizing the latent heat of stream 41. The 430 lb/hr of methanol exits V-106 as a vapor through stream 44 at 36 °C and 28 kPa. The remainder of stream 40 exits V-106 as a liquid through stream 43 at 36 °C and 41 kPa. Stream 43 is routed through a pump (L-115) to pressurize the stream to 76 kPa in order to be routed to the entry point of effect 7.

Stream 44 is routed to effect 7 (V-107) to utilize the latent heat of the stream as the heating agent for the vaporization of methanol in V-107. A pressure drop of 14 kPa occurs across the effect and the stream is completely condensed, exiting V-107 at 22 °C and 14 kPa. Stream 44 is routed to L-116 to pressurize the stream to 83 kPa before being combined with stream 42 as the methanol recycle stream. Stream 44 requires pressurization to overcome the Pressure of stream 42 and to prevent backflow. Stream 44 is added to stream 42 and they become stream 46. Stream 46 is a liquid phase stream at 39 °C and 69 kPa.

Stream 43 is routed to effect 7 (V-107) to vaporize additional methanol to continue to concentrate the feed stream. Stream 43 enters effect 7 at a pressure of 76 kPa and a

temperature of 36 °C, and the operating pressure of effect 7 is 14 kPa. 410 lb/hr of methanol with trace amounts of entrained lipids and water are vaporized by utilizing the flash effect of the pressure drop in the system and by utilizing the latent heat of stream 44. The 410 lb/hr of methanol exits V-107 as a vapor through stream 45 at 22 °C and 14 kPa. The remainder of stream 43 contains approximately 18 wt% of methanol, 30 wt% of water and 0.081 wt% of the heterotrophic basal media which creates a two phase system with the lipids as the lighter organic phase and the methanol/water as the heavier aqueous phase. The aqueous phase is separated and collected in a boot at the bottom of the final effect, with trace amounts of entrained lipids. The aqueous phase exits V-107 through stream 47 at 28 kPa and 22 °C. Stream 47 is routed through L-118 to be pressurized to 170 kPa and sent to a waste treatment facility. The lipids are collected as the product with trace amounts of entrained water/methanol. The remainder of stream 43 exits V-107 as a liquid through stream 48 at 22 °C and 28 kPa. Stream 48 is routed through L-117 to be pressurized to 170 kPa and sent to a product storage facility.

Stream 45 is routed through a 1-stage, 26 hp compressor (G-101) to pressurize the vapor stream. Stream 45 requires pressurization to overcome the pressure of stream 46 and to prevent backflow. Following G-101, stream 45 is at 280 °C and 180 kPa. Stream 45 is routed through a cross exchanger (E-103) to partially condense stream 45, while pre-heating the multi-effect evaporator feed stream (stream 25). Stream 45 exits E-103 as a mixed-phase stream at 68 °C and 120 kPa. The pressure drop across E-103 is 62 kPa, due to the requirement to route the stream to the beginning of the multi-effect evaporator system and back again. Stream 45 enters E-104 to completely condense it before merging with Stream 46 as the methanol recycle stream. Stream 45 exits E-104 as a liquid phase



stream at 59 °C and 83 kPa. Stream 45 is combined with stream 46 to form the methanol recycle stream (stream 23) at 42 °C and 69 kPa.

Stream 23 is routed to a pump (L-120) to pressurize stream 23 to 170 kPa. Stream 25 enters E-105 to adequately cool the recycle stream before re-entering the leacher. Stream 23 exits E-105 at 25 °C and 140 kPa. Moderately low temperature refrigerated water is required at a rate of 3,000 lb/hr and enters E-105 as stream 50 at 5 °C and 210 kPa and exits at 15 °C and 170 kPa.

APPENDIX B: CHAPTER 1 AUTOTROPHIC PROCESS  
DETAILED PROCESS DESCRIPTION

### *B.1 Detailed Process Description: Autotrophic Process*

Process flow diagrams (PFD) detail the unit operations necessary for microalgae oil extraction. Area 01- Growth and Cultivation is reported in Drawing 01-A-103. Area 02- Filtration and Crushing is reported in Drawing 02-A-103. Area 03- Extraction and Lipid Separation is reported in Drawing 03-A-103. These PFDs include mass balances for each unit operation, process temperature profiles, and process pressure profiles. The major equipment list is reported Table A.6 and details the specifications for each unit operation included in the PFDs. Appendix E reports the simulation data used to size the flash drum and necessary surrounding minor equipment. Appendix D reports the sample calculations used to size equipment.

#### *Area 01: Growth and Cultivation*

The initial microalgae seed is grown in a lab. The lab growth will yield 0.036 lb of microalgae in 4.5 lb of water, which is manually transferred to R-1001 A-C to initiate growth in the reactor.

The first process area starts with the reactors R-1001 A-C on Drawings 01-A-103 and 01-A-104. R-1001 A-C are clear, 400 L, polypropylene photo bioreactors which operate as a semi-batch configuration. The following description is for a single reactor (R-1001 A) out of three (R-1001 A-C).

R-1001 A (Sheet 01-A-104/01) is already filled with 1.2 lb of sterile air. In the first step, 490 lb of water is pumped into R-1001 A through stream 6, at 490 lb/hr, until the level reaches the water set point. The sterile air is vented through stream 60 to the atmosphere to maintain 100 kPa. In step 2, 59 lb of BBM in 40 lb of water is added to R-101 through stream 3, until the level reaches the media set point. Sterile air is vented through stream 60

to maintain 100 kPa. In step 3, 0.036 lb microalgae in 4.5 lb water is manually transferred from the lab to R-1001 A through stream 7. Sterile air is vented through stream 60 to maintain 100 kPa.

In step 4 (Sheet 01-A-104/02), carbon dioxide is bubbled into R-1001 A via stream 10 at 2.1 lb/hr, until the microalgae density reaches the target microalgae density after approximately 14 days. The carbon dioxide agitates the microalgae and provides a necessary carbon source for photosynthesis. The nutrients present in the BBM are consumed by the microalgae. Excess carbon dioxide and oxygen produced by the microalgae is vented through stream 60 to maintain 100 kPa. In step 5, 0.53 lb of microalgae in 530 lb of water is pumped by L-1001 A/D from R-1001 A to the next set of reactors, through stream 8 at 1,100 lb/hr. During the transfer, 1.2 lb of sterile air is added from stream 62 into R-1001 A to maintain 100 kPa. Step 5 ends when the liquid level reaches the minimum level set point. In step 6, 1.2 lb of low-pressure steam is added to R-1001 A through stream 63. Sterile air is vented through stream 60 to maintain 240 kPa until the pressure reaches the pressure set point.

In step 7 (Sheet 01-A-104/03), the low-pressure steam is held in R-1001 A for 20 minutes and ends when the time reaches the time set point. Holding the steam sterilizes the reactor of pathogens and remaining microalgae. In step 8, cooling water enters the R-1001 A cooling tube from stream 64 and exits through stream 65. The cooling tube condenses the low-pressure steam. The steam condensate and wastes are transferred out R-1001 A through stream 66 and pumped to waste treatment by L-2001 A/B. Sterile air is added from stream 62 to R-1001 A to help transfer the steam condensates and wastes and maintain

pressure at 100 kPa. Step 8 ends when all the steam is condensed, the condensate is out of the reactor, and the temperature reaches the temperature set point.

Reactors R-1001 A-C (Sheet 01-A-104/04) operate on a staggered 21 day cycle. R-1001 A starts step one on day 1, R-1001 B starts step one on day 15, and R-1001 C starts step one on day 8. In the cycle, 14 days are designated for cleaning, filling, and growing. Steps 1-3 and 6-8 are approximately 8 hours total. Step 4, the growth step, is 14 days and accounts for 65% of the total cycle time. In step 5, the reactors are drained over the course of 7 days to transfer microalgae to R-1002 – R-1045, and accounts for 1/3 of the total cycle time.

After R-1001 A-C are reactors R-1002 through R-1045 on Drawings 01-A-103 and 01-A105. Reactors R-1002 through R-1045 are clear, 530 gal, polypropylene photo bioreactors which operate as a semi-batch process to grow and transfer *C. Vulgaris*. The following description is for a single reactor (R-1002) out of 44 (R-1002 – R-1045). R-1002 (Sheet 01-A-105/01) is already filled with 5.9 lb of sterile air. In the first step, 3200 lb of water is pumped into R-1002 through stream 5 at 3,200 lb/hr, until the level reaches the water set point. The sterile air is vented through stream 67 to the atmosphere to maintain 100 kPa. In step 10, 360 lb of BBM in 200 lb water is added to R-1002 through stream 2, until the level reaches the media set point. Sterile air is vented through stream 67 to maintain 100 kPa. In step 11, 0.53 lb microalgae in 530 lb water is pumped by L-1001 A/B from R-1001 A-C, to R-1002 through stream 8. Sterile air is vented through stream 60 to maintain 100 kPa.

In step 12 (Sheet 01-A-105/02), carbon dioxide is bubbled into R-1002 via stream 11 at 11 lb/hr, until the microalgae density reaches the target microalgae density after

approximately 14 days. The carbon dioxide agitates the microalgae and provides a necessary carbon source for photosynthesis. The nutrients present in the BBM are consumed by the microalgae. Excess carbon dioxide and oxygen produced by the microalgae is vented through stream 67 to maintain 100 kPa. In step 13, 30 lb of microalgae in 4000 lb of water is pumped by L-1002 – L-1004 A/B from R-1002 to the next set of reactors, through stream 12 at 4000 lb/hr. During the transfer, 5.9 lb of sterile air is added from stream 69 into R-1002 to maintain 100 kPa. Step 13 ends when the liquid level reaches the minimum level set point. In step 14, 5.8 lb of low-pressure steam is added to R-1002 through stream 70. Sterile air is vented through stream 70 to maintain 240 kPa until the pressure reaches the pressure set point.

In step 15 (Sheet 01-A-105/03), the low-pressure steam is held in R-1002 for 20 minutes and ends when the time reaches the time set point. Holding the steam sterilizes the reactor of pathogens and remaining microalgae. In step 16, cooling water enters the R-1002 cooling tube from stream 71 and exits through stream 72. The cooling tube condenses the low-pressure steam. The steam condensate and wastes are transferred out R-1002 through stream 73 and pumped to waste treatment by L-2002 A/B. Sterile air is added from stream 69 to R-1002 to help transfer the steam condensates and wastes and maintain pressure at 100 kPa. Step 16 ends when all the steam is condensed, the condensate is out of the reactor, and the temperature reaches the temperature set point.

Reactors R-1002 through R-1045 (Sheet 01-A-105/04-11) operate on a staggered 15-day cycle with 3 reactors starting the cycle each day. Out of the three reactors per day, the first reactor drains for the first 8 hours of the day (step 13), is sterilized (steps 14-16), and then filled for growth (steps 9-12). The second reactor drains for the second eight hours

of the day (step 13), is sterilized (steps 14-16), and then filled for growth (steps 9-12). The third reactor drains for the last eight hours of the day (step 13) and is sterilized (steps 14-16) and filled for growth (steps 9-12) on the next day. In the 15-day cycle, steps 13-16 and 9-11 are 12 hours total, accounting for 3% of the total cycle time. Step 12, the growth step, accounts for the remaining 97%.

After R-1002 through R-1045 are reactors R-1046 through R-1689 on Drawings 01-A-502 and 01-A-517. Reactors R-1046 – R-1689 are clear, 6,600-gal, polypropylene photo bioreactors which operate in a semi-batch process to grow and transfer *C. Vulgaris*. The following description is for a single reactor (R-1046) out of 644 (R-1046 – R-1689). R-1046 (Sheet 01-A-106/01) is already filled with 74 lb of sterile air. In the first step, 46,000 lb of water is pumped into R-1046 through stream 13 at 46,000 lb/hr, until the level reaches the water set point. The sterile air is vented through stream 74 to the atmosphere to maintain 100 kPa. In step 18, 3,700 lb of BBM in 2500 lb of water is added to R-1046 through stream 14, until the level reaches the media set point. Sterile air is vented through stream 74 to maintain 100 kPa. In step 19, 35 lb microalgae in 4,000 lb water is pumped by L-1002 – L-1004 A/B from the previous set of reactors, to R-1046 through stream 12. Sterile air is vented through stream 74 to maintain 100 kPa.

In step 20 (Sheet 01-A-106/02), carbon dioxide is bubbled into R-1046 via stream 15 at 130 lb/hr, until the microalgae density reaches the target microalgae density after approximately 14 days. The carbon dioxide agitates the microalgae and provides a necessary carbon source for photosynthesis. The nutrients present in the BBM are consumed by the microalgae. Excess carbon dioxide and oxygen produced by the microalgae are vented through stream 74 to maintain 100 kPa. In step 21, 440 lb of

microalgae in 55,000 lb of water is pumped by L-1005 – L-1050 A/B from R-1046 to the accumulation tanks (T-1001 A-C), through stream 16 at 56,000 lb/hr. During the transfer, 74 lb of sterile air is added from stream 76 into R-1046 to maintain 100 kPa. Step 21 ends when the liquid level reaches the minimum level set point. In step 22, 72 lb of low-pressure steam is added to R-1046 through stream 77. Sterile air is vented through stream 74 to maintain 240 kPa until the pressure reaches the pressure set point.

In step 23 (Sheet 01-A-106/03), the low-pressure steam is held in R-1046 for 20 minutes and ends when the time reaches the time set point. Holding the steam sterilizes the reactor of pathogens and remaining microalgae. In step 24, cooling water enters the R-1046 cooling tube from stream 78 and exits through stream 79. The cooling tube condenses the low-pressure steam. The steam condensate and wastes are transferred out R-1046 through stream 80 and pumped to waste treatment by L-2046 A/B. Sterile air is added from stream 76 to R-1046 to help transfer the steam condensates and wastes and maintain pressure at 100 kPa. Step 24 ends when all the steam is condensed, the condensate is out of the reactor, and the temperature reaches the temperature set point. Reactors R-1046 through R-1689 (Sheet 01-A-106/04-10) operate on a staggered 14-day cycle with 46 reactors starting the cycle each day. Out of the 46 reactors per day, 23 feed the accumulation tank at a time. Steps 17-19 and 21-24 are a total of 12 hours, which accounts for 4% of the total cycle time. Step 20, the growth step, accounts for the remaining 96%.

After R-1046 through R-1689 are accumulation tanks T-1001 A-C, on Drawings 01-A-502 and 01-A-518. T-1001 A-C are carbon steel, 22,000 ft<sup>3</sup> tanks that accumulate flow from reactors R-1046 – R-1689 and feed the vacuum filter (H-1001 A/B). The following description is for a single tank (T-1001 A) out of three (T-1001 A-C). T-1001



A (Sheet 01-A-107/01) is already filled with 1,600 lb of sterile air. In the first step, 3,200 lb microalgae in 410,000 lb water is pumped from 23 reactors of R-1046 through R1689, to T-1001 A through stream 16. Sterile air is vented through stream 81 to maintain 100 kPa. In step 26, 3200 lb of microalgae in 410,000 lb of water is pumped by L-1051 A/B from T-1001 A to H-1001 A/B, through stream 17 at 100,000 lb/hr. During the transfer, 1600 lb of sterile air is added from stream 82 into T-1001 A to maintain 100 kPa. Step 26 ends when the liquid level reaches the minimum level set point.

In step 27 (Sheet 01-A-107/02), 490 lb of low-pressure steam is added to T-1001 A through stream 83. Sterile air is vented through stream 81 to maintain 240 kPa until the pressure reaches the pressure set point. In step 28, the low-pressure steam is held in T-1001 A for 20 minutes and ends when the time reaches the time set point. Holding the steam sterilizes the reactor of pathogens and remaining microalgae. In step 29, cooling water enters the T1001 A cooling jacket from stream 84 and exits through stream 85. The cooling jacket condenses the low-pressure steam. The steam condensate and wastes are transferred out T1001 A through stream 86 and pumped to waste treatment by L-2090 A/B. Sterile air is added from stream 82 to T-1001 A to help transfer the steam condensates and wastes and maintain pressure at 100 kPa. Step 29 ends when all the steam is condensed, the condensate is out of the reactor, and the temperature reaches the temperature set point. T-1001 A-C (Sheet 01-A-107/03) operate on a staggered 1.5-day cycle. T-1001 A starts step 25 at the beginning of day 0.5, T-1001 B starts step 25 at the beginning of day 1, and T-1001 C starts step 25 at the beginning of day 1.5. Filling the tank, step 25, takes 2 hours. Draining the tank, step 26, takes 12 hours. Sterilizing the tank, steps 27-29, and takes 12 hours.

### *Area 02: Filtration and Crushing*

Stream 17 enters the vacuum filter (H-1001 A/B) on Drawing 02-A-103 at a flow rate of 100,000 lb/hr. The vacuum pressure applied filters out water at a rate of 100,000 lb/hr, leaving H-1001 A/B as stream 18. The microalgae sludge leaves H-1001 A/B as stream 19 and is transported via a conveyor (J-1001 A/B) to a filter press (H-1002 A/B) to further separate water from the microalgae. 95% of the water in the sludge is filtered out and leaves H-1002 A/B as stream 20 at a rate of 40 lb/hr.

Stream 18 is increased to a pressure of 110 kPa using L-1052 A/B to prevent backflow into stream 20. These two streams become stream 21 and is sent through a feed pump (L-1053 A/B) to increase the pressure from 97 kPa to 240 kPa. The water is sterilized to 120 °C in E1001 A/B by heating it with 16,000 lb/hr of low-pressure steam. Heating stream 21 allows the water and BBM to be recycled back into the growth tanks. The sterilized water leaves E-1001 A/B and is cooled by 15,000 lb/hr cooling water in E-1015 A/B from 120 °C to 25 °C. Stream 56 enters T-1002 where 10 minutes of flow is accumulated to dampen the water system, and then supply the growth tanks through stream 4 at 47,000 lb/hr. The dried microalgae leaves H-1002 A/B, stream 25, and is transported to the grinder (C1001) by a conveyor (J-1002 A/B). Within C-1001, the cell walls of the microalgae are broken down to improve the lipid extraction. The crushed microalgae leaves C-1001 as stream 269 and is transported to the next process area, detailed in Drawing 03-A-103, with a conveyor (J-1003 A/B) at a rate of 840 lb/hr.

### *Area 03: Extraction and Flash Separation*

Stream 26 enters Area 03, detailed in Drawing 03-A-103. A screw feeder (J-1004 A/B) feeds the microalgae into the leacher (D-1001) where methanol is utilized as the

solvent for extraction of the lipids from the biomass. Entrained water from the filter press (H-1002 A/B) is present in the leacher (D-1001) at the rate of 150 lb/hr in stream 26. The methanol is fed into the process at D-1001 at a rate of 6,600 lb/hr as stream 29. The entrained water is completely absorbed into the methanol fraction. Upon extraction of the lipids, the methanol-lipid mixture with entrained water is routed to the multi-effect evaporator (Sheet 03-A-103/02) as stream 31 at a rate of 6,900 lb/hr. The microalgae biomass with entrained methanol, which contains trace amounts of water, leaves D-1001 as stream 30, at a rate of 740 lb/hr, to be sold as high protein animal feed by-product. Stream 31 first enters a pump (L-1073), reported in Sheet 03-A-103/08 to adequately pressurize the stream to be able to travel through a cross-exchanger (E-1003) and enter effect 1 (V-1001). Stream 25 then routed to a cross exchanger (E-1003) to pre-heat the evaporator feed stream to minimize the amount of low-pressure steam required for effect 1 of the multi-stage evaporator. Stream 31 is being heated utilizing the top product (stream 45) of effect 7 containing 620 lb/hr of vaporized methanol. Stream 31 partially condenses stream 87, while stream 31 approaches the vaporization temperature.

Stream 31 is routed to effect 1 of the multi-effect evaporator, which is reported in Sheet 03-A-103/02. Stream 31 enters effect 1 at a pressure of 100 kPa and a temperature of 63 °C, and the operating pressure of effect 1 is 97 kPa. 360 lb/hr of low-pressure steam vaporizes 690 lb/hr of methanol with trace amounts of entrained lipids and water. The 690 lb/hr of methanol exits V-1001 as a vapor through stream 34 at 64 °C and 97 kPa. The remainder of stream 31 exits V-1001 as a liquid through stream 35 at 64 °C and 110 kPa. Stream 35 is routed through a pump (L-1055) to pressurize the stream to 140 kPa in order to be routed to the entry point of effect 2.

Stream 34 is routed to effect 2 (V-1002) to utilize the latent heat of the stream as the heating agent for the vaporization of methanol in V-1002. A pressure drop of 14 kPa occurs across the effect and the stream is completely condensed, exiting V-1002 at 59 °C and 83 kPa. In order to avoid the vaporization in the methanol recycle stream, stream 34 is sub-cooled in E-1002 using 220 lb/hr of process cooling water. The process cooling water (stream 32) enters E-1002 at 30 °C and 210 kPa and exits E-1002 at 45 °C and 170 kPa. Stream 34 exits E-1002 at 69 kPa, due to the 14 kPa pressure drop, and 49 °C.

Stream 35 is routed to effect 2 (V-1002) to vaporize additional methanol to continue to concentrate the feed stream. Stream 34 enters effect 2 at a pressure of 97 kPa and a temperature of 64 °C, and the operating pressure of effect 2 is 88 kPa. 680 lb/hr of methanol with trace amounts of entrained lipids and water are vaporized by utilizing the flash effect of the pressure drop in the system and by utilizing the latent heat of stream 34. The 680 lb/hr of methanol exits V-1002 as a vapor through stream 37 at 15 °C and 88 kPa. The remainder of stream 35 exits V-1002 as a liquid through stream 36 at 15 °C and 100 kPa. Stream 36 is routed through a pump (L-1056) to pressurize the stream to 140 kPa in order to be routed to the entry point of effect 3.

Stream 37 is routed to effect 3 (V-1003) to utilize the latent heat of the stream as the heating agent for the vaporization of methanol in V-1003. A pressure drop of 14 kPa occurs across the effect and the stream is completely condensed, exiting V-1003 at 57 °C and 74 kPa. Stream 37 is added to stream 34 and become stream 38. Stream 38 is a liquid phase stream at 43 °C and 69 kPa.

Stream 36 is routed to effect 3 (V-1003) to vaporize additional methanol to continue to concentrate the feed stream. Stream 36 enters effect 3 at a pressure of 88 kPa and a

temperature of 15 °C, and the operating pressure of effect 3 is 78 kPa. 680 lb/hr of methanol with trace amounts of entrained lipids and water are vaporized by utilizing the flash effect of the pressure drop in the system and by utilizing the latent heat of stream 37. The 680 lb/hr of methanol exits V-1003 as a vapor through stream 40 at 58 °C and 78 kPa. The remainder of stream 36 exits V-1003 as a liquid through stream 39 at 58 °C and 92 kPa. Stream 39 is routed through a pump (L-1057) to pressurize the stream to 130 kPa in order to be routed to the entry point of effect 4.

Stream 40 is routed to effect 4 (V-1004) to utilize the latent heat of the stream as the heating agent for the vaporization of methanol in V-1004. A pressure drop of 14 kPa occurs across the effect and the stream is completely condensed, exiting V-1004 at 54 °C and 64 kPa. Stream 40 is routed to L-1058 to pressurize the stream to 76 kPa before being combined with stream 38 as the methanol recycle stream. Stream 40 requires pressurization to overcome the pressure of stream 38 and to prevent backflow. Stream 40 is added to stream 38 and become stream 41. Stream 41 is a liquid phase stream at 47 °C and 69 kPa. Stream 39 is routed to effect 4 (V-1004) to vaporize additional methanol to continue to concentrate the feed stream. Stream 39 enters effect 4 at a pressure of 130 kPa and a temperature of 58 °C, and the operating pressure of effect 4 is 69 kPa. 670 lb/hr of methanol with trace amounts of entrained lipids and water are vaporized by utilizing flash effect of the pressure drop in the system and by utilizing the latent heat of stream 40. The 670 lb/hr of methanol exits V-1004 as a vapor through stream 43 at 56 °C and 69 kPa. The remainder of stream 39 exits V-1004 as a liquid through stream 42 at 56 °C and 83 kPa. Stream 42 is routed through a pump (L-1059) to pressurize the stream to 120 kPa in order to be routed to the entry point of effect 5.

Stream 43 is routed to effect 5 (V-1005) to utilize the latent heat of the stream as the heating agent for the vaporization of methanol in V-1005. A pressure drop of 14 kPa occurs across the effect and the stream is completely condensed, exiting V-1005 at 50 °C and 55 kPa. Stream 43 is routed to L-1060 to pressurize the stream to 83 kPa before being combined with stream 41 as the methanol recycle stream. Stream 43 requires pressurization to overcome the pressure of stream 41 and to prevent backflow. Stream 43 is added to stream 41 and become stream 44. Stream 44 is a liquid phase stream at 48 °C and 69 kPa. Stream 42 is routed to effect 5 (V-1005) to vaporize additional methanol to continue to concentrate the feed stream. Stream 42 enters effect 5 at a pressure of 69 kPa and a temperature of 56 °C, and the operating pressure of effect 5 is 60 kPa. 670 lb/hr of methanol with trace amounts of entrained lipids and water are vaporized by utilizing the flash effect of the pressure drop in the system and by utilizing the latent heat of stream 43. The 660 lb/hr of methanol exits V-1005 as a vapor through stream 46 at 52 °C and 60 kPa. The remainder of stream 42 exits V-1005 as a liquid through stream 45 at 52 °C and 69 kPa. Stream 45 is routed through a pump (L-1061) to pressurize the stream to 110 kPa in order to be routed to the entry point of effect 6.

Stream 46 is routed to effect 6 (V-1006) to utilize the latent heat of the stream as the heating agent for the vaporization of methanol in V-1006. A pressure drop of 14 kPa occurs across the effect and the stream is completely condensed, exiting V-1006 at 46 °C and 46 kPa. Stream 46 is routed to L-1062 to pressurize the stream to 83 kPa before being combined with stream 44 as the methanol recycle stream. Stream 46 requires pressurization to overcome the pressure of stream 44 and to prevent backflow. Stream 46 is added to stream 44 and become stream 47. Stream 47 is a liquid phase stream at 47 °C and 69 kPa.

Stream 45 is routed to effect 6 (V-1006) to vaporize additional methanol to continue to concentrate the feed stream. Stream 45 enters effect 6 at a pressure of 60 kPa and a temperature of 52 °C, and the operating pressure of effect 6 is 50 kPa. 650 lb/hr of methanol with trace amounts of entrained lipids and water are vaporized by utilizing the flash effect of the pressure drop in the system and by utilizing the latent heat of stream 46. The 650 lb/hr of methanol exits V-1006 as a vapor through stream 49 at 48 °C and 50 kPa. The remainder of stream 45 exits V-1006 as a liquid through stream 48 at 48 °C and 64 kPa. Stream 48 is routed through a pump (L-1063) to pressurize the stream to 99 kPa in order to be routed to the entry point of effect 7.

Stream 49 is routed to effect 7 (V-1007) to utilize the latent heat of the stream as the heating agent for the vaporization of methanol in V-1007. A pressure drop of 14 kPa occurs across the effect and the stream is completely condensed, exiting V-1007 at 41 °C and 37 kPa. Stream 49 is routed to L-1064 to pressurize the stream to 83 kPa before being combined with stream 47 as the methanol recycle stream. Stream 49 requires pressurization to overcome the pressure of stream 47 and to prevent backflow. Stream 49 is added to stream 47 and become stream 50. Stream 50 is a liquid phase stream at 46 °C and 69 kPa. Stream 48 is routed to effect 7 (V-1007) to vaporize additional methanol to continue to concentrate the feed stream. Stream 48 enters effect 7 at a pressure of 50 kPa and a temperature of 48 °C, and the operating pressure of effect 7 is 41 kPa. 650 lb/hr of methanol with trace amounts of entrained lipids and water are vaporized by utilizing the flash effect of the pressure drop in the system and by utilizing the latent heat of stream 49. The 650 lb/hr of methanol exits V-1007 as a vapor through stream 52 at 44 °C and 41 kPa. The remainder of stream 48 exits V-1007 as a liquid through stream 51 at 44 °C and 55 kPa.

Stream 51 is routed through a pump (L-1065) to pressurize the stream to 90 kPa in order to be routed to the entry point of effect 8.

Stream 52 is routed to effect 8 (V-1008) to utilize the latent heat of the stream as the heating agent for the vaporization of methanol in V-1008. A pressure drop of 14 kPa occurs across the effect and the stream is completely condensed, exiting V-1008 at 35 °C and 28 kPa. Stream 52 is routed to L-1066 to pressurize the stream to 83 kPa before being combined with stream 50 as the methanol recycle stream. Stream 52 requires pressurization to overcome the pressure of stream 50 and to prevent backflow. Stream 52 is added to stream 50 and become stream 53. Stream 53 is a liquid phase stream at 45 °C and 69 kPa. Stream 51 is routed to effect 8 (V-1008) to vaporize additional methanol to continue to concentrate the feed stream. Stream 51 enters effect 8 at a pressure of 41 kPa and a temperature of 44 °C, and the operating pressure of effect 8 is 32 kPa. 640 lb/hr of methanol with trace amounts of entrained lipids and water are vaporized by utilizing the flash effect of the pressure drop in the system and by utilizing the latent heat of stream 52. The 640 lb/hr of methanol exits V-1008 as a vapor through stream 55 at 39 °C and 32 kPa. The remainder of stream 51 exits V-1008 as a liquid through stream 54 at 39 °C and 46 kPa. Stream 54 is routed through a pump (L-1067) to pressurize the stream to 81 kPa in order to be routed to the entry point of effect 9.

Stream 55 is routed to effect 9 (V-1009) to utilize the latent heat of the stream as the heating agent for the vaporization of methanol in V-1009. A pressure drop of 14 kPa occurs across the effect and the stream is completely condensed, exiting V-1009 at 27 °C and 19 kPa. Stream 55 is routed to L-1068 to pressurize the stream to 83 kPa before being combined with stream 53 as the methanol recycle stream. Stream 55 requires pressurization



to overcome the pressure of stream 53 and to prevent backflow. Stream 55 is added to stream 53 and become stream 56. Stream 56 is a liquid phase stream at 43 °C and 69 kPa. Stream 54 is routed to effect 9 (V-1009) to vaporize additional methanol to continue to concentrate the feed stream. Stream 54 enters effect 9 at a pressure of 32 kPa and a temperature of 39 °C, and the operating pressure of effect 9 is 23 kPa. 630 lb/hr of methanol with trace amounts of entrained lipids and water are vaporized by utilizing the flash effect of the pressure drop in the system and by utilizing the latent heat of stream 55. The 630 lb/hr of methanol exits V-1009 as a vapor through stream 58 at 32 °C and 23 kPa. The remainder of stream 51 exits V-1008 as a liquid through stream 57 at 32 °C and 23 kPa. Stream 57 is routed through a pump (L-1069) to pressurize the stream to 71 kPa in order to be routed to the entry point of effect 10.

Stream 58 is routed to effect 10 (V-1010) to utilize the latent heat of the stream as the heating agent for the vaporization of methanol in V-1010. A pressure drop of 14 kPa occurs across the effect and the stream is completely condensed, exiting V-1010 at 14 °C and 9 kPa. Stream 58 is routed to L-1070 to pressurize the stream to 83 kPa before being combined with stream 56 as the methanol recycle stream. Stream 58 requires pressurization to overcome the pressure of stream 56 and to prevent backflow. Stream 58 is added to stream 56 and become stream 59. Stream 59 is a liquid phase stream at 41 °C and 69 kPa.

Stream 58 is routed to effect 10 (V-1010) to vaporize additional methanol to continue to concentrate the feed stream. Stream 58 enters effect 10 at a pressure of 23 kPa and a temperature of 32 °C, and the operating pressure of effect 10 is 14 kPa. 620 lb/hr of methanol with trace amounts of entrained lipids and water are vaporized by utilizing the flash effect of the pressure drop in the system and by utilizing the latent heat of stream 58.

The 620 lb/hr of methanol exits V-1010 as a vapor through stream 87 at 22 °C and 14 kPa. The remainder of stream 57 contains approximately 20 wt% of methanol, 43 wt% of water and 0.15 wt% of bolds basal media components which creates a two-phase system with the lipids as the lighter organic phase and the methanol/water as the heavier aqueous phase. The aqueous phase is separated and collected in a boot at the bottom of the final effect, with trace amounts of entrained lipids. The aqueous phase exits V-1010 through stream 89 at 28 kPa and 22 °C. Stream 89 is routed through L-1072 to be pressurized to 170 kPa and sent to a waste treatment facility. The lipids are collected as the product with trace amounts of entrained water/methanol. The remainder of stream 57 exits V-1010 as a liquid through stream 88 at 22 °C and 28 kPa. Stream 88 is routed through L-1071 to be pressurized to 170 kPa to a product storage facility.

Stream 87 is routed through a single-stage, 40 hp compressor (G-1001) to pressurize the vapor stream. Stream 87 requires pressurization to overcome the pressure of stream 59 and to prevent backflow. Following G-1001, stream 87 is at 280 °C and 180 kPa. Stream 87 is routed through a cross exchanger (E-1003) to partially condense stream 87, while preheating the multi-effect evaporator feed stream (stream 31). Stream 87 exits E-1003 as a mixed-phase stream at 68 °C and 120 kPa. The pressure drop across E-1003 is 62 kPa, due to the requirement to route the stream to the beginning of the multi-effect evaporator system and back again. Stream 87 enters E-1004 to completely condense it before merging with Stream 59 as the methanol recycle stream. Stream 87 exits E-1004 as a liquid phase stream at 59 °C and 83 kPa. Stream 87 is combined with stream 59 to form the methanol recycle stream (stream 23) at 42 °C and 83 kPa.

Stream 23 is routed to L-1074 to pressurize stream 23 to 170 kPa. Stream 23 enters E-1005 to adequately cool the recycle stream before re-entering the leacher. Stream 23 exits E1005 at 25 °C and 140 kPa. Moderately low temperature refrigerated water is required at a rate of 6,500 lb/hr and enter E-1005 as stream 50 at 5 °C and 210 kPa and exits at 15 °C and 170 kPa.

APPENDIX C: CHAPTER 1 HETEROTROPHIC PROCESS  
MAJOR EQUIPMENT LIST

Table C1. Major Equipment List for Heterotrophic Process:

<b>Equipment Specifications</b>	
<b>Equipment Name/Description</b>	C-101 A/B
<b>Equipment Specifications</b>	Fine Grinder
Process Area	1
Capacity (kg/hr)	180
Power (hp)	30
Size Spec (µm)	5
MOC	Carbon Steel

<b>Equipment Specifications</b>		
<b>Equipment Name/Description</b>	D-101	D-102
<b>Equipment Specifications</b>	Leacher	Surge Drum
Process Area	2	2
Height (m)	2.5	1.9
Diameter (m)	3.7	0.64
Operating Temperature (°C)	25	25
Operating Pressure (kPa)	100	140
MOC	Carbon Steel	Carbon Steel

<b>Equipment Specifications</b>	
<b>Equipment Name/Description</b>	G-101
<b>Equipment Specifications</b>	Gas Compressor
Process Area	2
Fluid	Methanol
Number of stages	1
MOC	Carbon Steel
Inlet Pressure (kPa)	14
Outlet Pressure (kPa)	180
Inlet Temperature (°C)	22
Outlet Temperature (°C)	282
Volumetric Flow Rate (kg/hr)	180
Power (hp)	26

Table C1 Continued. Major Equipment List for Heterotrophic Process:

<b>Equipment Specifications</b>	
<b>Equipment Name/Description</b>	H-101 A/B
<b>Equipment Specifications</b>	Rotary Drum Filter
Process Area	1
Area (m <sup>2</sup> )	2.6
Diameter (m)	0.91
Rotation Speed (rpm)	0.1
Power (hp)	0.5
Particle Size	9
MOC	Carbon Steel

<b>Equipment Specifications</b>	
<b>Equipment Name/Description</b>	H-102 A/B
<b>Equipment Specifications</b>	Belt Press
Process Area	1
Area (m <sup>2</sup> )	3.3
Belt Movement Power (hp)	0.5
Capacity (L/hr)	490

<b>Equipment Specifications</b>			
<b>Equipment Name/Description</b>	R-101 A-C	R-102 A-D	T-101
<b>Equipment Specifications</b>	Algae Growth Reactor 1	Algae Growth Reactor 2	Process Water Recycle Holding Tank
Process Area	1	1	1
Height (m)	1.1	8.5	12
Diameter (m)	1.6	13	19
Temperature (°C)	25	25	25
Pressure (kPa)	100	100	170
MOC	Carbon Steel	Carbon Steel	Carbon Steel

Table C1 Continued. Major Equipment List for Heterotrophic Process:

<b>Equipment Specifications</b>						
<b>Equipment Name/Description</b>	E-101 A/B	E-102 A/B	E-103 A/B	E-104 A/B	E-105 A/B	E-106 A/B
<b>Equipment Specifications</b>	Water Sterilizer	Methanol Pre-Cooler	Methanol Pre-Cooler	Methanol Pre-Cooler	Methanol Pre-Cooler	Water Sterilizer
Process Area	1	2	2	2	2	1
Duty (MJ/hr)	3.6	0.0037	0.14	0.0037	0.057	3.7
Shell Inlet Temperature (°C)	149	59	282	66	42	16
Shell Outlet Temperature (°C)	143	52	66	59	25	121
Shell Pressure (kPa)	450	83	180	120	170	210
Shell MOC	Carbon Steel	Carbon Steel	Carbon Steel	Carbon Steel	Carbon Steel	Carbon Steel
Shell Fluid	Steam	Methanol	Methanol	Methanol	Methanol	Methanol
Tube Inlet Temperature (°C)	25	30	25	30	5	5
Tube Outlet Temperature (°C)	121	45	63	45	15	25
Tube Pressure (kPa)	240	170	140	210	210	210
Tube MOC	Carbon Steel	Carbon Steel	Carbon Steel	Carbon Steel	Carbon Steel	Carbon Steel
Tube Fluid	Recycled Process Water	Process Cooling Water	Methanol/Lipids	Process Cooling Water	Moderately Low Temperature Refrigerated Water	Sterilized Process Water
Overall Heat Transfer Coefficient (W/m <sup>2</sup> *°C)	560	57	160	220	120	470
Area (m <sup>2</sup> )	28	1.0	5.6	1.0	5.9	180

Table C1 Continued. Major Equipment List for Heterotrophic Process:

<b>Equipment Specifications</b>						
<b>Equipment Name/Description</b>	J-101 A/B	J-102 A/B	J-103 A/B	J-104 A/B	J-105 A/B	J-106 A/B
<b>Equipment Specifications</b>	Conveyor to H-102	Conveyor to C-101	Conveyor to J-104	Screw Feeder to D-101	Screw Feeder from D-101	Conveyor from D-101
Process Area	1	1	1, 2	2	2	2
Length (m)	15	15	58	4.5	4.5	94
Width (m)	0.61	0.61	0.61	0.10	0.10	0.61
Power (hp)	1	1	1	0.25	0.25	1
Delivery Pressure (kPa)	-	-	-	100	100	-
Capacity (kg/hr)	190	180	180	180	120	120
MOC	Carbon Steel	Carbon Steel	Carbon Steel	Carbon Steel	Carbon Steel	Carbon Steel

<b>Equipment Specifications</b>							
<b>Equipment Name/Description</b>	V-101	V-102	V-103	V-104	V-105	V-106	V-107
<b>Equipment Specifications</b>	Multi-Effect Evaporator Effect 1	Multi-Effect Evaporator Effect 2	Multi-Effect Evaporator Effect 3	Multi-Effect Evaporator Effect 4	Multi-Effect Evaporator Effect 5	Multi-Effect Evaporator Effect 6	Multi-Effect Evaporator Effect 7
Process Area	2	2	2	2	2	2	2
Height (m)	2.0	2.0	2.0	2.0	2.0	2.0	2.0
Top Diameter (m)	0.40	0.40	0.40	0.40	0.40	0.40	0.40
Bottom Diameter (m)	0.79	0.79	0.79	0.79	0.79	0.79	0.79
Inlet Temperature (°C)	63	64	60	56	51	44	36
Outlet Temperature (°C)	64	60	56	51	44	36	22
Pressure (kPa)	97	83	69	55	41	28	14
Area (ft <sup>2</sup> )	5.3	5.3	5.3	5.3	5.3	5.3	5.3
Duty (GJ/hr)	1.1	0.87	0.63	0.57	0.23	0.19	0.051
MOC	Carbon Steel	Carbon Steel	Carbon Steel	Carbon Steel	Carbon Steel	Carbon Steel	Carbon Steel



Table C1 Continued. Major Equipment List for Heterotrophic Process:

<b>Equipment Specifications</b>						
<b>Equipment Name/Description</b>	L-101 A-C/D/E/F	L-102 A-C/D/E/F	L-103 A/B	L-104 A/B	L-105 A/B	L-106 A/B
<b>Equipment Specifications</b>	Feed Pump to R-102	Feed Pump to H-101	Feed Pump to L-104	Feed Pump to E-101	Water Recycle from H-102 to Stream 16	V-101 Bottoms Stream
Process Area	1	1	1	1	1	2
Power (hp)	0.25	0.25	0.5	0.75	0.25	0.25
Mass Flow Rate (kg/hr)	4,400	9,100	9,100	9,100	8.6	1,300
Inlet Pressure (kPa)	100	100	28	97	97	110
Outlet Pressure (kPa)	190	120	120	240	120	140
Temperature (°C)	25	25	25	25	25	64
Fluid Components	Algae, Water	Algae, Water	Water	Water	Water	Methanol/ Lipids
Solid Loading (%)	2	2	0	0	0	0
MOC	Carbon Steel	Carbon Steel	Carbon Steel	Carbon Steel	Carbon Steel	Carbon Steel

Table C1 Continued. Major Equipment List for Heterotrophic Process:

<b>Equipment Specifications</b>						
<b>Equipment Name/Description</b>	L-107 A/B	L-108 A/B	L-109 A/B	L-110 A/B	L-111 A/B	L-112 A/B
<b>Equipment Specifications</b>	V-102 Bottoms Stream	Methanol Recycle Feed Pump from V-103	V-103 Bottoms Stream	Methanol Recycle Feed Pump from V-104	V-104 Bottoms Stream	Methanol Recycle Feed Pump from V-105
Process Area	2	2	2	2	2	2
Power (hp)	0.25	0.25	0.25	0.25	0.25	0.25
Mass Flow Rate (kg/hr)	1,100	190	860	190	640	180
Inlet Pressure (kPa)	97	69	83	55	69	34
Outlet Pressure (kPa)	131	76	120	76	100	76
Temperature (°C)	60	55	56	50	51	43
Fluid Components	Methanol/ Lipids	Methanol	Methanol/ Lipids	Methanol	Methanol/ Lipids	Methanol
Solid Loading (%)	0	0	0	0	0	0
MOC	Carbon Steel	Carbon Steel	Carbon Steel	Carbon Steel	Carbon Steel	Carbon Steel

Table C1 Continued. Major Equipment List for Heterotrophic Process:

<b>Equipment Specifications</b>						
<b>Equipment Name/Description</b>	L-113 A/B	L-114 A/B	L-115 A/B	L-116 A/B	L-117 A/B	L-118 A/B
<b>Equipment Specifications</b>	V-105 Bottoms Stream	Methanol Recycle Feed Pump from V-106	V-106 Bottoms Stream	Methanol Recycle Feed Pump from V-107	Lipid Product Feed Pump	Methanol/Water Waste Treatment Feed Pump
Process Area	2	2	2	2	2	2
Power (hp)	0.25	0.25	0.25	0.25	0.25	0.25
Mass Flow Rate (kg/hr)	500	190	300	190	59	1.8
Inlet Pressure (kPa)	55	28	41	14	14	14
Outlet Pressure (kPa)	90	76	76	76	170	170
Temperature (°C)	44	35	36	22	22	22
Fluid Components	Methanol/Lipids	Methanol	Methanol/Lipids	Methanol	Lipids	Methanol/ Lipids
Solid Loading (%)	0	0	0	0	0	0
MOC	Carbon Steel	Carbon Steel	Carbon Steel	Carbon Steel	Carbon Steel	Carbon Steel

<b>Equipment Specifications</b>				
<b>Equipment Name/Description</b>	L-119 A/B	L-120 A/B	L-201 A-C /D/E/F	L-202 A-D /E/F/G/H
<b>Equipment Specifications</b>	Feed Pump to E-103	Feed Pump to E-105	Steam Condensate Return Pump from R-101	Steam Condensate Return Pump from R-102
Process Area	2	2	1	1
Power (hp)	0.25	0.25	0.25	0.25
Mass Flow Rate (kg/hr)	1,400	1,400	3,000	3,000
Inlet Pressure (kPa)	100	100	100	100
Outlet Pressure (kPa)	140	140	140	140
Temperature (°C)	25	25	25	25a
Fluid Components	Methanol/Lipids	Methanol	Steam Condensate	Steam Condensate
Solid Loading (%)	0	0	0	0
MOC	Carbon Steel	Carbon Steel	Carbon Steel	Carbon Steel

APPENDIX D: CHAPTER 1 AUTOTROPHIC PROCESS MAJOR EQUIPMENT LIST

Table D1. Major Equipment List for Autotrophic Process:

<b>Equipment Specifications</b>	
<b>Equipment Number</b>	C-1001 A/B
<b>Equipment Name/Description</b>	Fine Grinder
Process Area	2
Capacity (kg/hr)	380
Power (hp)	30
Size Spec ( $\mu\text{m}$ )	5
MOC	Carbon Steel

<b>Equipment Specifications</b>		
<b>Equipment Number</b>	D-1001	D-1002
<b>Equipment Name/Description</b>	Leacher	Surge Drum
Process Area	3	3
Height (m)	25	2.4
Diameter (m)	3.7	0.82
Operating Temperature ( $^{\circ}\text{C}$ )	25	25
Operating Pressure (kPa)	100	140
MOC	Carbon Steel	Carbon Steel

<b>Equipment Specifications</b>	
<b>Equipment Number</b>	H-1001 A/B
<b>Equipment Name/Description</b>	Rotary Drum Filter
Process Area	2
Area ( $\text{m}^2$ )	3.5
Diameter (m)	1.2
Rotation Speed (rpm)	0.15
Power (hp)	0.5
Particle Size ( $\mu\text{m}$ )	9
MOC	Carbon Steel

<b>Equipment Specifications</b>	
<b>Equipment Number</b>	H-1002 A/B
<b>Equipment Name/Description</b>	Belt Press
Process Area	2
Area ( $\text{m}^2$ )	3.3
Belt Movement Power (hp)	0.5
Capacity (L/hr)	680

Table D1 Continued. Major Equipment List for Autotrophic Process:

<b>Equipment Specifications</b>						
<b>Equipment Number</b>	E-1001 A/B	E-1002 A/B	E-1003 A/B	E-1004 A/B	E-1005 A/B	E-1006 A/B
<b>Equipment Name/Description</b>	Heat Exchanger	Heat Exchanger	Heat Exchanger	Heat Exchanger	Heat Exchanger	Heat Exchanger
Process Area	2	3	3	3	3	2
Duty (GJ/hr)	19	0.0056	0.20	0.074	0.083	18
Shell Inlet Temperature (°C)	149	60	25	65	43	16
Shell Outlet Temperature (°C)	143	49	66	60	25	121
Shell Pressure (kPa)	450	83	140	120	170	210
Shell MOC	Carbon Steel	Carbon Steel	Carbon Steel	Carbon Steel	Carbon Steel	Carbon Steel
Shell Fluid	Steam	Methanol	Methanol/ Lipids	Methanol	Methanol	Cooling Water
Tube Inlet Temperature (°C)	25	30	282	30	5	121
Tube Outlet Temperature (°C)	121	43	66	43	9.4	25
Tube Pressure (kPa)	240	140	180	210	210	210
Tube MOC	Carbon Steel	Carbon Steel	Carbon Steel	Carbon Steel	Carbon Steel	Carbon Steel
Tube Fluid	Water	Process Cooling Water	Methanol	Process Cooling Water	Moderately Low Temperature Refrigerated Water	Sterilized Process Water
Overall Heat Transfer Coefficient (W/m <sup>2</sup> )	520	57	160	220	120	850
Area (m <sup>2</sup> )	160	1.6	7.2	4.5	7.9	1,000

Table D1 Continued. Major Equipment List for Autotrophic Process:

<b>Equipment Specifications</b>						
<b>Equipment Number</b>	J-1001 A/B	J-1002 A/B	J-1003 A/B	J-1004 A/B	J-1005 A/B	J-1005 A/B
<b>Equipment Name/Description</b>	Conveyor to H-1002	Conveyor to C-1001	Conveyor to J-1004	Screw Feeder to D-1001	Screw Feeder from D-1002	Conveyor from D-1002
Process Area	2	2	2, 3	3	3	3
Length (m)	15	15	15	4.6	4.6	94
Width (m)	0.61	0.61	0.61	0.1	0.1	0.61
Power (hp)	1	1	1	0.25	0.5	1
Delivery Pressure (kPa)	-	-	-	100	100	-
Capacity (kg/hr)	400	380	380	380	320	340
MOC	Carbon Steel	Carbon Steel	Carbon Steel	Carbon Steel	Carbon Steel	Carbon Steel

<b>Equipment Specifications</b>	
<b>Equipment Number</b>	G-1001
<b>Equipment Name/Description</b>	Gas Compressor
Process Area	3
Fluid	Methanol
Number of stages	1
MOC	Carbon Steel
Inlet Pressure (kPa)	14
Outlet Pressure (kPa)	180
Inlet Temperature (°C)	22
Outlet Temperature (°C)	282
Volumetric Flow Rate (kg /hr)	280
Power (hp)	40

Table D1 Continued. Major Equipment List for Autotrophic Process:

<b>Equipment Specifications</b>						
<b>Equipment Number</b>	L-1001 A/B	L-1002-1004 A/B	L-1005- 1050 A/B	L-1051 A/B	L-1052 A/B	L-1053 A/B
<b>Equipment Name/Description</b>	Feed Pump to R-1002-R-1045	Feed Pump to R-1046-R-1689	Feed Pump to Holding Tank	Feed Pump to H-1001	Feed Pump to L-1053	Feed Pump to E-1001
Process Area	1	1	1	1	2	2
Power (hp)	0.25	0.25	0.25	0.25	2	3.5
Mass Flow Rate (kg/hr)	500	4,000	8,600	45,000	45,000	45,000
Inlet Pressure (kPa)	100	100	100	100	28	100
Outlet Pressure (kPa)	140	110	120	110	110	240
Temperature (°C)	25	25	25	25	25	25
Fluid Components	Algae, Water	Algae, Water	Algae, Water	Algae, Water	Water	Water
Solid Loading (%)	1	1	1	1	0	0
MOC	Carbon Steel	Carbon Steel	Carbon Steel	Carbon Steel	Carbon Steel	Carbon Steel

<b>Equipment Specifications</b>						
<b>Equipment Number</b>	L-1054 A/B	L-1055 A/B	L-1056 A/B	L-1057 A/B	L-1058 A/B	L-1059 A/B
<b>Equipment Name/Description</b>	Water Recycle from H-1002 to Stream 21	V-1001 Bottoms Stream	V-1002 Bottoms Stream	V-1003 Bottoms Stream	Methanol Recycle Feed Pump from V-1004	V-1004 Bottoms Stream
Process Area	2	3	3	3	3	3
Power (hp)	0.25	0.25	0.25	0.25	0.25	0.25
Mass Flow Rate (kg/hr)	18	2,800	2,500	2,200	310	1,900
Inlet Pressure (kPa)	97	110	100	92	64	83
Outlet Pressure (kPa)	120	140	140	130	80	120
Temperature (°C)	25	64	61	58	54	56
Fluid Components	Water	Methanol/Lipids	Methanol/Lipids	Methanol/Lipids	Methanol	Methanol/ Lipids
Solid Loading (%)	0	0	0	0	0	0
MOC	Carbon Steel	Carbon Steel	Carbon Steel	Carbon Steel	Carbon Steel	Carbon Steel



Table D1 Continued. Major Equipment List for Autotrophic Process:

<b>Equipment Specifications</b>						
<b>Equipment Number</b>	L-1060 A/B	L-1061 A/B	L-1062 A/B	L-1063 A/B	L-1064 A/B	L-1065 A/B
<b>Equipment Name/Description</b>	Methanol Recycle Feed Pump from V-1005	V-1005 Bottoms Stream	Methanol Recycle Feed Pump from V-1006	V-1006 Bottoms Stream	Methanol Recycle Feed Pump from V-1007	V-1007 Bottoms Stream
Process Area	3	3	3	3	3	3
Power (hp)	0.25	0.25	0.25	0.25	0.25	0.25
Mass Flow Rate (kg/hr)	300	1,600	600	1,300	290	1,100
Inlet Pressure (kPa)	55	74	46	64	37	55
Outlet Pressure (kPa)	83	110	83	99	83	90
Temperature (°C)	49	52	46	48	43	44
Fluid Components	Water	Methanol/ Lipids	Methanol	Methanol/ Lipids	Methanol	Methanol/ Lipids
Solid Loading (%)	0	0	0	0	0	0
MOC	Carbon Steel	Carbon Steel	Carbon Steel	Carbon Steel	Carbon Steel	Carbon Steel

Table D1 Continued. Major Equipment List for Autotrophic Process:

<b>Equipment Specifications</b>						
<b>Equipment Number</b>	L-1066 A/B	L-1067 A/B	L-1068 A/B	L-1069 A/B	L-1070 A/B	L-1071 A/B
<b>Equipment Name/Description</b>	Methanol Recycle Feed Pump from V-1008	V-1008 Bottoms Stream	Methanol Recycle Feed Pump from V-1009	V-1009 Bottoms Stream	Methanol Recycle Feed Pump from V-1010	Lipids Product Feed Pump
Process Area	3	3	3	3	3	3
Power (hp)	0.25	0.25	0.25	0.25	0.25	0.25
Mass Flow Rate (kg/hr)	290	730	270	440	290	59
Inlet Pressure (kPa)	28	46	19	37	9.0	14
Outlet Pressure (kPa)	83	81	83	71	83	170
Temperature (°C)	35	39	27	32	14	22
Fluid Components	Methanol	Methanol/ Lipids	Methanol	Methanol/ Lipids	Methanol	Lipids
Solid Loading (%)	0	0	0	0	0	0
MOC	Carbon Steel	Carbon Steel	Carbon Steel	Carbon Steel	Carbon Steel	Carbon Steel

Table D1 Continued. Major Equipment List for Autotrophic Process:

<b>Equipment Specifications</b>				
<b>Equipment Number</b>	L-1072 A/B	L-1073 A/B	L-1074 A/B	L-2001-L-2649 A/B
<b>Equipment Name/Description</b>	Methanol/Water Waste Treatment Feed Pump	Feed Pump to E-1003	Feed Pump to E-1005	Steam Condensate Return Pump from R-1046-R-1689
Process Area	3	3	3	1
Power (hp)	0.25	0.25	0.25	0.25
Mass Flow Rate (kg/hr)	1.8	3,000	3,000	45,000
Inlet Pressure (kPa)	14	100	83	100
Outlet Pressure (kPa)	170	140	170	140
Temperature (°C)	22	25	43	25
Fluid Components	Methanol/Water	Methanol/Lipids	Methanol	Water
Solid Loading (%)	0	0	0	0
MOC	Carbon Steel	Carbon Steel	Carbon Steel	Carbon Steel

<b>Equipment Specifications</b>			
<b>Equipment Number</b>	R-1001 A-C	R-1002-1045	R-1046-1689
<b>Equipment Name/Description</b>	Photobioreactor	Photobioreactor	Photobioreactor
Process Area	1	1	1
Diameter (m)	0.40	0.40	0.40
Length (m)	4.4	16	190
Volume (L)	420	2,000	25,000
Temperature (°C)	25	25	25
Pressure (kPa)	100	100	100
MOC	Polypropylene	Polypropylene	Polypropylene

Table D1 Continued. Major Equipment List for Autotrophic Process:

<b>Equipment Specifications</b>		
<b>Equipment Number</b>	T-1001 A-C	T-1002 A-C
<b>Equipment Name/Description</b>	Holding Tank	Holding Tank
Process Area	1	2
Diameter (ft)	23	46
Length (ft)	35	31
Temperature (°C)	25	25
Pressure (kPa)	20	20
MOC	Carbon Steel	Carbon Steel

<b>Equipment Specifications</b>					
<b>Equipment Number</b>	V-1001	V-1002	V-1003	V-1004	V-1005
<b>Equipment Name/Description</b>	Multi-Effect Evaporator Effect 1	Multi-Effect Evaporator Effect 2	Multi-Effect Evaporator Effect 3	Multi-Effect Evaporator Effect 4	Multi-Effect Evaporator Effect 5
Process Area	3	3	3	3	3
Height (m)	2.5	2.5	2.5	2.5	2.5
Top Diameter (m)	1.0	1.0	1.0	1.0	1.0
Bottom Diameter (m)	0.52	0.52	0.52	0.52	0.52
Inlet Temperature (°C)	63	64	61	58	56
Outlet Temperature (°C)	64	61	58	56	52
Pressure (kPa)	100	100	92	83	74
Area (m <sup>2</sup> )	10	10	10	10	10
Duty (GJ/hr)	1.9	1.2	1.1	1.1	0.84
MOC	Carbon Steel	Carbon Steel	Carbon Steel	Carbon Steel	Carbon Steel

Table D1 Continued. Major Equipment List for Autotrophic Process:

<b>Equipment Specifications</b>					
<b>Equipment Number</b>	V-1006	V-1007	V-1008	V-1009	V-1010
<b>Equipment Name/Description</b>	Multi-Effect Evaporator Effect 6	Multi-Effect Evaporator Effect 7	Multi-Effect Evaporator Effect 8	Multi-Effect Evaporator Effect 9	Multi-Effect Evaporator Effect 10
Process Area	3	3	3	3	3
Height (m)	2.5	2.5	2.5	2.5	2.5
Top Diameter (m)	1.0	1.0	1.0	1.0	1.0
Bottom Diameter (m)	0.52	0.52	0.52	0.52	0.52
Inlet Temperature (°C)	52	48	44	39	32
Outlet Temperature (°C)	48	44	39	32	22
Pressure (kPa)	64	55	46	37	58
Area (m <sup>2</sup> )	10	10	10	10	10
Duty (MMBtu/ft)	0.75	0.47	0.41	0.21	0.056
MOC	Carbon Steel	Carbon Steel	Carbon Steel	Carbon Steel	Carbon Steel

APPENDIX E: CHAPTER 1 OPERATIONAL CASH FLOW SHEETS

Table E1. Operational Cash Flow Sheet for Heterotrophic Process

Job Title: Oil Extraction from Heterotrophic Microalgae

Location: Texas

Basis Date:

Oct 2016

Year	Raw Materials	Chemicals & Catalysts	Operating Labor	Maintenance	Utilities	Royalties & Patent Fees	Other Expenses	Yearly Total
1	\$ 880,000	\$ 180,000	\$ 1,600,000	\$ 660,000	\$ 370,000	\$ -	\$ 28	\$ 3,700,000
2	\$ 880,000	\$ 180,000	\$ 1,600,000	\$ 660,000	\$ 370,000	\$ -	\$ 28	\$ 3,700,000
3	\$ 880,000	\$ 180,000	\$ 1,600,000	\$ 660,000	\$ 370,000	\$ -	\$ 28	\$ 3,700,000
4	\$ 880,000	\$ 180,000	\$ 1,600,000	\$ 660,000	\$ 370,000	\$ -	\$ 28	\$ 3,700,000
5	\$ 880,000	\$ 180,000	\$ 1,600,000	\$ 660,000	\$ 370,000	\$ -	\$ 28	\$ 3,700,000
6	\$ 880,000	\$ 180,000	\$ 1,600,000	\$ 660,000	\$ 370,000	\$ -	\$ 28	\$ 3,700,000
7	\$ 880,000	\$ 180,000	\$ 1,600,000	\$ 660,000	\$ 370,000	\$ -	\$ 28	\$ 3,700,000
8	\$ 880,000	\$ 180,000	\$ 1,600,000	\$ 660,000	\$ 370,000	\$ -	\$ 28	\$ 3,700,000
9	\$ 880,000	\$ 180,000	\$ 1,600,000	\$ 660,000	\$ 370,000	\$ -	\$ 28	\$ 3,700,000
10	\$ 880,000	\$ 180,000	\$ 1,600,000	\$ 660,000	\$ 370,000	\$ -	\$ 28	\$ 3,700,000
11	\$ 880,000	\$ 180,000	\$ 1,600,000	\$ 660,000	\$ 370,000	\$ -	\$ 28	\$ 3,700,000
12	\$ 880,000	\$ 180,000	\$ 1,600,000	\$ 660,000	\$ 370,000	\$ -	\$ 28	\$ 3,700,000
13	\$ 880,000	\$ 180,000	\$ 1,600,000	\$ 660,000	\$ 370,000	\$ -	\$ 28	\$ 3,700,000
14	\$ 880,000	\$ 180,000	\$ 1,600,000	\$ 660,000	\$ 370,000	\$ -	\$ 28	\$ 3,700,000
15	\$ 880,000	\$ 180,000	\$ 1,600,000	\$ 660,000	\$ 370,000	\$ -	\$ 28	\$ 3,700,000
16	\$ 880,000	\$ 180,000	\$ 1,600,000	\$ 660,000	\$ 370,000	\$ -	\$ 28	\$ 3,700,000
17	\$ 880,000	\$ 180,000	\$ 1,600,000	\$ 660,000	\$ 370,000	\$ -	\$ 28	\$ 3,700,000
18	\$ 880,000	\$ 180,000	\$ 1,600,000	\$ 660,000	\$ 370,000	\$ -	\$ 28	\$ 3,700,000
19	\$ 880,000	\$ 180,000	\$ 1,600,000	\$ 660,000	\$ 370,000	\$ -	\$ 28	\$ 3,700,000
20	\$ 880,000	\$ 180,000	\$ 1,600,000	\$ 660,000	\$ 370,000	\$ -	\$ 28	\$ 3,700,000

Note: Numbers may not sum to total due to rounding

Table E2 Operational Cash Flow Sheet for the Autotrophic Process

Job Title: Oil Extraction from Autotrophic Microalgae

Location: Texas

Basis Date: Oct 2016

Year	Raw Materials	Chemicals & Catalysts	Operating Labor	Maintenance	Utilities	Royalties & Patent Fees	Other Expenses	Yearly Total
1	\$ 7,400,000	\$ 2,300,000	\$ 14,000,000	\$ 4,400,000	\$ 210,000,000	\$ -	\$ 60	\$ 240,000,000
2	\$ 7,400,000	\$ 2,300,000	\$ 14,000,000	\$ 4,400,000	\$ 210,000,000	\$ -	\$ 60	\$ 240,000,000
3	\$ 7,400,000	\$ 2,300,000	\$ 14,000,000	\$ 4,400,000	\$ 210,000,000	\$ -	\$ 60	\$ 240,000,000
4	\$ 7,400,000	\$ 2,300,000	\$ 14,000,000	\$ 4,400,000	\$ 210,000,000	\$ -	\$ 60	\$ 240,000,000
5	\$ 7,400,000	\$ 2,300,000	\$ 14,000,000	\$ 4,400,000	\$ 210,000,000	\$ -	\$ 60	\$ 240,000,000
6	\$ 7,400,000	\$ 2,300,000	\$ 14,000,000	\$ 4,400,000	\$ 210,000,000	\$ -	\$ 60	\$ 240,000,000
7	\$ 7,400,000	\$ 2,300,000	\$ 14,000,000	\$ 4,400,000	\$ 210,000,000	\$ -	\$ 60	\$ 240,000,000
8	\$ 7,400,000	\$ 2,300,000	\$ 14,000,000	\$ 4,400,000	\$ 210,000,000	\$ -	\$ 60	\$ 240,000,000
9	\$ 7,400,000	\$ 2,300,000	\$ 14,000,000	\$ 4,400,000	\$ 210,000,000	\$ -	\$ 60	\$ 240,000,000
10	\$ 7,400,000	\$ 2,300,000	\$ 14,000,000	\$ 4,400,000	\$ 210,000,000	\$ -	\$ 60	\$ 240,000,000
11	\$ 7,400,000	\$ 2,300,000	\$ 14,000,000	\$ 4,400,000	\$ 210,000,000	\$ -	\$ 60	\$ 240,000,000
12	\$ 7,400,000	\$ 2,300,000	\$ 14,000,000	\$ 4,400,000	\$ 210,000,000	\$ -	\$ 60	\$ 240,000,000
13	\$ 7,400,000	\$ 2,300,000	\$ 14,000,000	\$ 4,400,000	\$ 210,000,000	\$ -	\$ 60	\$ 240,000,000
14	\$ 7,400,000	\$ 2,300,000	\$ 14,000,000	\$ 4,400,000	\$ 210,000,000	\$ -	\$ 60	\$ 240,000,000
15	\$ 7,400,000	\$ 2,300,000	\$ 14,000,000	\$ 4,400,000	\$ 210,000,000	\$ -	\$ 60	\$ 240,000,000
16	\$ 7,400,000	\$ 2,300,000	\$ 14,000,000	\$ 4,400,000	\$ 210,000,000	\$ -	\$ 60	\$ 240,000,000
17	\$ 7,400,000	\$ 2,300,000	\$ 14,000,000	\$ 4,400,000	\$ 210,000,000	\$ -	\$ 60	\$ 240,000,000
18	\$ 7,400,000	\$ 2,300,000	\$ 14,000,000	\$ 4,400,000	\$ 210,000,000	\$ -	\$ 60	\$ 240,000,000
19	\$ 7,400,000	\$ 2,300,000	\$ 14,000,000	\$ 4,400,000	\$ 210,000,000	\$ -	\$ 60	\$ 240,000,000
20	\$ 7,400,000	\$ 2,300,000	\$ 14,000,000	\$ 4,400,000	\$ 210,000,000	\$ -	\$ 60	\$ 240,000,000

Note: Numbers may not sum to total due to rounding



APPENDIX F: CHAPTER 1 CAPITAL COST SUMMARY TABLES

Table F1. Capital Cost Summary for Heterotrophic Process

Job Title: Oil Extraction from Heterotrophic Microalgae

Page 1 of 11

Location: Texas

Basis Date: Oct 2016

ID#	Equipment Description	# of Units	Capacity/Size Specification	PEC Cp 2004	Cp 2016	Material Factor, F <sub>M</sub>	Pressure/Other Factor, F <sub>p</sub>	Actual BMF, F <sub>BM</sub>	Actual BMC, CBM	Total BMC
<b>Crushers</b>										
C-101 A/B	Fine Grinder	2	Capacity: 180 kg/hr Power: 30 hp MOC: Carbon Steel	\$ -	\$79,000	-	-	2.8	\$220,000	\$440,000
<b>Pressure Vessels</b>										
D-101	Leacher	1	Height: 2.5 m Diameter: 3.7 m MOC: Carbon Steel	\$ 5,500	\$ 7,500	1.0	1.2	4.5	\$ 34,000	\$ 34,000
D-102	Surge Drum	1	Height: 1.9 m Diameter: 0.64 m MOC: Carbon Steel	\$ 2,400	\$ 3,300	1.0	1.2	3.3	\$ 11,000	\$ 11,000
<b>Heat Exchangers</b>										
E-101 A/B	Water Sterilization	2	Duty: 3.6 GJ/hr Area: 28 m <sup>2</sup> MOC: Carbon Steel	\$ 5,600	\$ 7,600	1.0	1.0	3.1	\$ 24,000	\$ 48,000
E-102 A/B	Heat Exchanger	2	Duty: 0.0037 GJ/hr Area: 1.0 m <sup>2</sup> MOC: Carbon Steel	\$ 1,900	\$ 2,600	1.0	1.0	3.1	\$ 8,100	\$ 16,000

Note: Numbers may not sum to total due to rounding

**Table F1.** Capital Cost Summary for Heterotrophic Process

Job Title: Oil Extraction from Heterotrophic Microalgae

Location: Texas

Page 2 of 11

Basis Date: Oct 2016

ID#	Equipment Description	# of Units	Capacity/Size Specification	PEC Cp 2004	Cp 2016	Material Factor, F <sub>M</sub>	Pressure/Other Factor, F <sub>P</sub>	Actual BMF, F <sub>BM</sub>	Actual BMC, CBM	Total BMC
<b>Heat Exchangers Continued</b>										
E-103 A/B	Heat Exchanger	2	Duty: 0.14GJ/hr Area: 5.6 m <sup>2</sup> MOC: Carbon Steel	\$ 3,000	\$ 4,100	1.0	1.0	3.1	\$ 13,000	\$ 26,000
E-104 A/B	Heat Exchanger	2	Duty: 0.0037 GJ/hr Area: 1.0 ft <sup>2</sup> MOC: Carbon Steel	\$ 1,900	\$ 2,600	1.0	1.0	3.1	\$ 8,100	\$ 16,000
E-105 A/B	Heat Exchanger	2	Duty: 0.057 GJ/hr Area: 5.9 m <sup>2</sup> MOC: Carbon Steel	\$ 3,000	\$ 4,100	1.0	1.0	3.1	\$ 13,000	\$ 26,000
E-106 A/B	Water Cooler	2	Duty: 3.6 GJ/hr Area: 28 m <sup>2</sup> MOC: Carbon Steel	\$ 5,600	\$ 7,600	1.0	1.0	3.1	\$ 24,000	\$ 48,000
<b>Compressor</b>										
G-101	Gas Compressor	1	Power: 26 hp MOC: Carbon Steel	\$ 22,000	\$30,000	-	-	2.5	\$160,000	\$160,000
G-101	Drive Shaft	1	Power: 26 hp MOC: Carbon Steel	\$ 18,000	\$24,000	-	-	3.5	\$ 84,000	\$ -

Note: Numbers may not sum to total due to rounding

**Table F1.** Capital Cost Summary for Heterotrophic Process

Job Title: Oil Extraction from Heterotrophic Microalgae

Location: Texas

Page 3 of 11

Basis Date: Oct 2016

ID#	Equipment Description	# of Units	Capacity/Size Specification	PEC Cp 2004	Cp 2016	Material Factor, F <sub>M</sub>	Pressure/ Other Factor, F <sub>p</sub>	Actual BMF, F <sub>BM</sub>	Actual BMC, CBM	Total BMC
<b>Filters</b>										
H-101 A/B	Vacuum Filter	2	Area: 2.6 m <sup>2</sup> Diameter: 0.91 m MOC: Carbon Steel	\$50,000	\$68,000	-	-	2.4	\$160,000	\$320,000
H-102 A/B	Belt Press	2	Area: 3.3 m <sup>2</sup> Power: 0.5 hp MOC: Carbon Steel	\$60,000	\$81,000	-	-	2.4	\$190,000	\$380,000
<b>Conveyors</b>										
J-101 A/B	Conveyor	2	Length: 15 m Width: 0.61 m Power: 1 hp MOC: Carbon Steel	\$ -	\$12,000	-	-	1.0	\$ 12,000	\$ 24,000
J-102 A/B	Conveyor	2	Length: 15 m Width: 0.61 m Power: 1 hp MOC: Carbon Steel	\$ -	\$12,000	-	-	1.0	\$ 12,000	\$ 24,000

Note: Numbers may not sum to total due to rounding

**Table F1.** Capital Cost Summary for Heterotrophic Process

Job Title: Oil Extraction from Heterotrophic Microalgae

Location: Texas

Page 4 of 11

Basis Date: Oct 2016

ID#	Equipment Description	# of Units	Capacity/Size Specification	PEC Cp 2004	Cp 2016	Material Factor, F <sub>M</sub>	Pressure/Other Factor, F <sub>P</sub>	Actual BMF, F <sub>BM</sub>	Actual BMC, CBM	Total BMC
<b>Conveyors Continued</b>										
J-103 A/B	Conveyor	2	Length: 15 m Width: 0.61 m Power: 1 hp MOC: Carbon Steel	\$ -	\$12,000	-	-	1.0	\$12,000	\$24,000
J-104 A/B	Screw Feeder	2	Length: 4.6 m Diameter: 0.10 m MOC: Carbon Steel	\$2,300	\$ 3,100	-	-	2.2	\$ 7,200	\$14,000
J-104 A/B	Screw Feeder Drive	2	Power: 0.25 hp	\$ 140	\$ 190	-	-	2.0	\$ 380	\$ -
J-105 A/B	Screw Feeder	2	Length: 4.6 m Diameter: 0.10 m MOC: Carbon Steel	\$2,300	\$ 3,100	-	-	2.2	\$ 7,200	\$14,000
J-105 A/B	Screw Feeder Drive	2	Power: 0.25 hp	\$ 140	\$ 190	-	-	2.0	\$ 380	\$ -

Note: Numbers may not sum to total due to rounding

**Table F1.** Capital Cost Summary for Heterotrophic Process  
Job Title: Oil Extraction from Heterotrophic Microalgae  
Location: Texas

ID#	Equipment Description	# of Units	Capacity/Size Specification	PEC Cp 2004	Cp 2016	Material Factor, F <sub>M</sub>	Pressure/ Other Factor, F <sub>P</sub>	Actual BMF, F <sub>BM</sub>	Actual BMC, CBM	Total BMC
<b>Pumps</b>										
L-101 A-C/ D/E/F	Feed Pump	6	Power: 0.25 hp Pressure: 190 kPa MOC: Carbon Steel	\$2,100	\$2,900	1.0	1.0	3.4	\$ 9,900	\$59,000
L-102 A-D/ E/F/G/H	Feed Pump	8	Power: 0.25 hp Pressure: 120 kPa MOC: Carbon Steel	\$2,100	\$2,900	1.0	1.0	3.4	\$ 9,900	\$79,000
L-103 A/B	Feed Pump	2	Power: 0.50 hp Pressure: 120 kPa MOC: Carbon Steel	\$2,600	\$3,500	1.0	1.0	3.4	\$12,000	\$24,000
L-104 A/B	Feed Pump	2	Power: 0.75 hp Pressure: 240 kPa MOC: Carbon Steel	\$3,100	\$4,200	1.0	1.0	3.4	\$14,000	\$28,000
L-105 A/B	Feed Pump	2	Power: 0.25 hp Pressure: 76 kPa MOC: Carbon Steel	\$2,600	\$3,500	1.0	1.0	3.4	\$12,000	\$24,000
L-106 A/B	Feed Pump	2	Power: 0.25 hp Pressure: 76 kPa MOC: Carbon Steel	\$2,100	\$2,900	1.0	1.0	3.4	\$ 9,900	\$20,000

Note: Numbers may not sum to total due to rounding

**Table F1.** Capital Cost Summary for Heterotrophic Process  
Job Title: Oil Extraction from Heterotrophic Microalgae  
Location: Texas

<b>ID#</b>	<b>Equipment Description</b>	<b># of Units</b>	<b>Capacity/Size Specification</b>	<b>PEC Cp 2004</b>	<b>Cp 2016</b>	<b>Material Factor, F<sub>M</sub></b>	<b>Pressure/Other Factor, F<sub>P</sub></b>	<b>Actual BMF, F<sub>BM</sub></b>	<b>Actual BMC, CBM</b>	<b>Total BMC</b>
<b>Pumps Continued</b>										
L-107 A/B	Feed Pump	2	Power: 0.25 hp Pressure: 83 kPa MOC: Carbon Steel	\$2,100	\$2,900	1.0	1.0	3.4	\$9,900	\$20,000
L-108 A/B	Feed Pump	2	Power: 0.25 hp Pressure: 83 kPa MOC: Carbon Steel	\$2,100	\$2,900	1.0	1.0	3.4	\$9,900	\$20,000
L-109 A/B	Feed Pump	2	Power: 0.25 hp Pressure: 83 kPa MOC: Carbon Steel	\$2,100	\$2,900	1.0	1.0	3.4	\$9,900	\$20,000
L-110 A/B	Feed Pump	2	Power: 0.25 hp Pressure: 170 kPa MOC: Carbon Steel	\$2,100	\$2,900	1.0	1.0	3.4	\$9,900	\$20,000
L-111 A/B	Feed Pump	2	Power: 0.25 hp Pressure: 170 kPa MOC: Carbon Steel	\$2,100	\$2,900	1.0	1.0	3.4	\$9,900	\$20,000
L-112 A/B	Feed Pump	2	Power: 0.25 hp Pressure: 140 kPa MOC: Carbon Steel	\$2,100	\$2,900	1.0	1.0	3.4	\$9,900	\$20,000

Note: Numbers may not sum to total due to rounding

**Table F1.** Capital Cost Summary for Heterotrophic Process  
Job Title: Oil Extraction from Heterotrophic Microalgae  
Location: Texas

ID#	Equipment Description	# of Units	Capacity/Size Specification	PEC Cp 2004	Cp 2016	Material Factor, F <sub>M</sub>	Pressure/ Other Factor, F <sub>p</sub>	Actual BMF, F <sub>BM</sub>	Actual BMC, CBM	Total BMC
<b>Pumps Continued</b>										
L-113 A/B	Feed Pump	2	Power: 0.25 hp Pressure: 170 kPa MOC: Carbon Steel	\$2,100	\$2,900	1.0	1.0	3.4	\$9,900	\$20,000
L-114 A/B	Feed Pump	2	Power: 0.25 hp Pressure: 170 kPa MOC: Carbon Steel	\$2,100	\$2,900	1.0	1.0	3.4	\$9,900	\$20,000
L-115 A/B	Feed Pump	2	Power: 0.25 hp Pressure: 170 kPa MOC: Carbon Steel	\$2,100	\$2,900	1.0	1.0	3.4	\$9,900	\$20,000
L-116 A/B	Feed Pump	2	Power: 0.25 hp Pressure: 170 kPa MOC: Carbon Steel	\$2,100	\$2,900	1.0	1.0	3.4	\$9,900	\$20,000
L-117 A/B	Feed Pump	2	Power: 0.25 hp Pressure: 170 kPa MOC: Carbon Steel	\$2,100	\$2,900	1.0	1.0	3.4	\$9,900	\$20,000
L-118 A/B	Feed Pump	2	Power: 0.25 hp Pressure: 170 kPa MOC: Carbon Steel	\$2,100	\$2,900	1.0	1.0	3.4	\$9,900	\$20,000

Note: Numbers may not sum to total due to rounding



**Table F1.** Capital Cost Summary for Heterotrophic Process  
Job Title: Oil Extraction from Heterotrophic Microalgae  
Location: Texas

<b>ID#</b>	<b>Equipment Description</b>	<b># of Units</b>	<b>Capacity/Size Specification</b>	<b>PEC Cp 2004</b>	<b>Cp 2016</b>	<b>Material Factor, F<sub>M</sub></b>	<b>Pressure/Other Factor, F<sub>p</sub></b>	<b>Actual BMF, F<sub>BM</sub></b>	<b>Actual BMC, CBM</b>	<b>Total BMC</b>
<b>Pumps Continued</b>										
L-119 A/B	Feed Pump	2	Power: 0.25 hp Pressure: 170 kPa MOC: Carbon Steel	\$2,100	\$2,900	1.0	1.0	3.4	\$9,900	\$20,000
L-120 A/B	Feed Pump	2	Power: 0.25 hp Pressure: 170 kPa MOC: Carbon Steel	\$2,100	\$2,900	1.0	1.0	3.4	\$9,900	\$20,000
L-121 A/B	Feed Pump	2	Power: 0.25 hp Pressure: 170 kPa MOC: Carbon Steel	\$2,100	\$2,900	1.0	1.0	3.4	\$9,900	\$20,000
L-201 A- C/D/E/F	SL Pump	6	Power: 0.25 hp Pressure: 170 kPa MOC: Carbon Steel	\$2,100	\$2,900	1.0	1.0	3.4	\$9,900	\$59,000
L-202 A-D/ E/F/G/H	SL Pump	8	Power: 0.25 hp Pressure: 140 kPa MOC: Carbon Steel	\$2,100	\$2,900	1.0	1.0	3.4	\$9,900	\$79,000

Note: Numbers may not sum to total due to rounding

**Table F1.** Capital Cost Summary for Heterotrophic Process

Job Title: Oil Extraction from Heterotrophic Microalgae

Location: Texas

Page 9 of 11

Basis Date: Oct 2016

ID#	Equipment Description	# of Units	Capacity/Size Specification	PEC Cp 2004	Cp 2016	Material Factor, F <sub>M</sub>	Pressure /Other Factor, F <sub>p</sub>	Actual BMF, F <sub>BM</sub>	Actual BMC, CBM	Total BMC
<b>Reactors</b>										
R-101 A-C	Algae Growth Reactor	3	Height: 1.1 m Diameter: 1.6 m Pressure: 100 kPa MOC: Carbon Steel	\$ 7,000	\$ 9,500	1.0	1.0	3.0	\$ 29,000	\$ 87,000
R-102 A-D	Algae Growth Reactor	4	Height: 8.5 m Diameter: 13 m Pressure: 100 kPa MOC: Carbon Steel	\$300,000	\$410,000	1.0	1.0	3.0	\$1,200,000	\$4,800,000
<b>Tanks</b>										
T-101	Water Recycle Tank	1	Height: 12 m Diameter: 19 m Pressure: 140 kPa MOC: Carbon Steel	\$ 8,000	\$ 11,000	1.0	1.0	2.1	\$ 23,000	\$ 23,000
<b>Evaporators</b>										
V-101	Evaporator	1	Height: 2.0 m Top Diameter: 0.79 m Bottom Diameter: 0.40 m MOC: Carbon Steel	\$ 2,300	\$ 3,100	2.9	1.0	2.9	\$ 9,000	\$ 9,000

Note: Numbers may not sum to total due to rounding

**Table F1.** Capital Cost Summary for Heterotrophic Process

Job Title: Oil Extraction from Heterotrophic Microalgae

Location: Texas

Page 10 of 11

Basis Date: Oct 2016

ID#	Equipment Description	# of Units	Capacity/Size Specification	PEC Cp 2004	Cp 2016	Material Factor, F <sub>M</sub>	Pressure/Other Factor, F <sub>p</sub>	Actual BMF, F <sub>BM</sub>	Actual BMC, CBM	Total BMC
<b>Evaporators Continued</b>										
V-102	Evaporator	1	Height: 2.0 m Top Diameter: 0.79 m Bottom Diameter: 0.40 m MOC: Carbon Steel	\$2,300	\$3,100	2.9	1.0	2.9	\$9,000	\$9,000
V-103	Evaporator	1	Height: 2.0 m Top Diameter: 0.79 m Bottom Diameter: 0.40 m MOC: Carbon Steel	\$2,300	\$3,100	2.9	1.0	2.9	\$9,000	\$9,000
V-104	Evaporator	1	Height: 2.0 m Top Diameter: 0.79 m Bottom Diameter: 0.40 m MOC: Carbon Steel	\$2,300	\$3,100	2.9	1.0	2.9	\$9,000	\$9,000
V-105	Evaporator	1	Height: 2.0 m Top Diameter: 0.79 m Bottom Diameter: 0.40 m MOC: Carbon Steel	\$2,300	\$3,100	2.9	1.0	2.9	\$9,000	\$9,000

Note: Numbers may not sum to total due to rounding

**Table F1.** Capital Cost Summary for Heterotrophic Process  
 Job Title: Oil Extraction from Heterotrophic Microalgae  
 Location: Texas

ID#	Equipment Description	# of Units	Capacity/Size Specification	PEC Cp 2004	Cp 2016	Material Factor, F <sub>M</sub>	Pressure/ Other Factor, F <sub>p</sub>	Actual BMF, F <sub>BM</sub>	Actual BMC, CBM	Total BMC
<b>Evaporators Continued</b>										
V-106	Evaporator	1	Height: 2.0 m Top Diameter: 0.79 m Bottom Diameter: 0.40 m MOC: Carbon Steel	\$2,300	\$3,100	2.9	1.0	2.9	\$ 9,000	\$ 9,000
V-107	Evaporator	1	Height: 2.0 m Top Diameter: 0.79 m Bottom Diameter: 0.40 m MOC: Carbon Steel	\$2,300	\$3,100	2.9	1.0	2.9	\$ 9,000	\$ 9,000
<b>Total Bare Modular Cost</b>									<b>C<sub>TBM</sub> »</b>	\$ 7,200,000
<b>Contingency and Fee</b>									<b>C<sub>TM</sub> CTBM * 0.18 =</b>	\$ 1,300,000
<b>Total Module Cost</b>									<b>C<sub>TM</sub> »</b>	\$ 8,500,000
<b>Auxiliary Facilities</b>									<b>C<sub>AUX</sub> CTM * 0.30 =</b>	\$ 2,600,000
<b>Fixed Capital Investment</b>									<b>FCI »</b>	\$11,000,000
<b>Working Capital</b>									<b>C<sub>wc</sub> FCI*0.15 =</b>	\$ 1,700,000
<b>Chemicals and Catalysts</b>										\$ 340,000
<b>Total Capital Investment</b>									<b>TCI »</b>	\$13,000,000

Note: Numbers may not sum to total due to rounding

Table F2. Capital Cost Summary for Autotrophic Process

Job Title: Oil Extraction from Autotrophic Microalgae

Page 1 of 12

Location: Texas

Basis Date: Oct 2016

ID#	Equipment Description	# of Units	Capacity/Size Specification	PEC Cp 2004	Cp 2016	Material Factor, F <sub>M</sub>	Pressure/ Other Factor, F <sub>p</sub>	Actual BMF, F <sub>BM</sub>	Actual BMC, CBM	Total BMC
<b>Crusher</b>										
C-1001 A/B	Fine Grinder	2	Capacity: 380 kg/hr Power: 30 hp MOC: Carbon Steel	\$ -	\$79,000	-	-	2.8	\$220,000	\$440,000
<b>Pressure Vessels</b>										
D-1001	Leacher	1	Height: 2.5 m Diameter: 3.7 m MOC: Carbon Steel	\$ 5,500	\$ 7,500	1.0	1.2	4.5	\$ 34,000	\$ 34,000
D-1002	Surge Drum	1	Height: 2.4 m Diameter: 0.82 m MOC: Carbon Steel	\$ 3,300	\$ 4,500	1.0	1.2	3.3	\$ 15,000	\$ 15,000
<b>Heat Exchanger</b>										
E-1001 A/B	Water Sterilization	2	Duty: 19 GJ/hr Area: 160 m <sup>2</sup> MOC: Carbon Steel	\$11,000	\$15,000	1.0	1.0	3.1	\$ 47,000	\$ 47,000
E-1002 A/B	Heat Exchanger	2	Duty: 0.0056 GJ/hr Area: 1.6 m <sup>2</sup> MOC: Carbon Steel	\$ 2,000	\$ 2,700	1.0	1.0	3.1	\$ 8,400	\$ 17,000
E-1003 A/B	Heat Exchanger	2	Duty: 0.20 GJ/hr Area: 7.2 m <sup>2</sup> MOC: Carbon Steel	\$ 3,100	\$ 4,200	1.0	1.0	3.1	\$ 13,000	\$ 26,000

Note: Numbers may not sum to total due to rounding

**Table F2** Capital Cost Summary for Autotrophic Process  
Job Title: Oil Extraction from Autotrophic Microalgae  
Location: Texas

<b>ID#</b>	<b>Equipment Description</b>	<b># of Units</b>	<b>Capacity/Size Specification</b>	<b>PEC Cp 2004</b>	<b>Cp 2016</b>	<b>Material Factor, F<sub>M</sub></b>	<b>Pressure/Other Factor, F<sub>p</sub></b>	<b>Actual BMF, F<sub>BM</sub></b>	<b>Actual BMC, CBM</b>	<b>Total BMC</b>
<b>Heat Exchanger Continued</b>										
E-1004 A/B	Heat Exchanger	2	Duty: 0.074 GJ/hr Area: 4.5 m <sup>2</sup> MOC: Carbon Steel	\$ 2,600	\$ 3,500	1.0	1.0	3.1	\$ 11,000	\$ 22,000
E-1005 A/B	Heat Exchanger	2	Duty: 0.083 GJ/hr Area: 7.9 m <sup>2</sup> MOC: Carbon Steel	\$ 3,300	\$ 4,500	1.0	1.0	3.1	\$ 14,000	\$ 28,000
E-1006 A/B	Water Sterilization	2	Duty: 19 GJ/hr Area: 160 m, <sup>2</sup> MOC: Carbon Steel	\$11,000	\$15,000	1.0	1.0	3.1	\$ 47,000	\$ 94,000
<b>Compressor</b>										
G-1001	Gas Compressor	1	Power: 40 hp MOC: Carbon Steel	\$33,000	\$45,000	-	-	2.5	\$220,000	\$220,000
G-1001	Drive	1	Power: 40 hp MOC: Carbon Steel	\$22,000	\$30,000	-	-	3.5	\$110,000	\$ -
<b>Filters</b>										
H-1001 A/B	Vacuum Filter	2	Area: 3.5 m <sup>2</sup> Diameter: 1.2 m MOC: Carbon Steel	\$90,000	\$120,000	-	-	2.4	\$290,000	\$580,000

Note: Numbers may not sum to total due to rounding

**Table F2** Capital Cost Summary for Autotrophic Process

Job Title: Oil Extraction from Autotrophic Microalgae

Page 3 of 12

Location: Texas

Basis

Date: Oct 2016

ID#	Equipment Description	# of Units	Capacity/Size Specification	PEC Cp 2004	Cp 2016	Material Factor, F <sub>M</sub>	Pressure/ Other Factor, F <sub>p</sub>	Actual BMF, F <sub>BM</sub>	Actual BMC, CBM	Total BMC
<b>Filters Continued</b>										
H-1002 A/B	Belt Press	2	Area: 3.3 m <sup>2</sup> Power: 0.5 hp MOC: Carbon Steel	\$60,000	\$81,000	-	-	2.4	\$190,000	\$380,000
<b>Conveyors</b>										
J-1001 A/B	Conveyor	2	Length: 15 m Width: 0.61 m Power: 1 hp MOC: Carbon Steel	\$ -	\$12,000	-	-	1.0	\$ 12,000	\$ 24,000
J-1002 A/B	Conveyor	2	Length: 15 m Width: 0.61 m Power: 1 hp MOC: Carbon Steel	\$ -	\$12,000	-	-	1.0	\$ 12,000	\$ 24,000
J-1003 A/B	Conveyor	2	Length: 15 m Width: 0.61 m Power: 1 hp MOC: Carbon Steel	\$ -	\$12,000	-	-	1.0	\$ 12,000	\$ 24,000
J-1004 A/B	Screw Feeder	2	Length: 15 m Width: 0.61 m MOC: Carbon Steel	\$ 2,300	\$ 3,100	-	-	2.2	\$ 7,180	\$ 14,000

Note: Numbers may not sum to total due to rounding

**Table F2** Capital Cost Summary for Autotrophic Process  
Job Title: Oil Extraction from Autotrophic Microalgae  
Location: Texas

<b>ID#</b>	<b>Equipment Description</b>	<b># of Units</b>	<b>Capacity/Size Specification</b>	<b>PEC Cp 2004</b>	<b>Cp 2016</b>	<b>Material Factor, F<sub>M</sub></b>	<b>Pressure/Other Factor, F<sub>p</sub></b>	<b>Actual BMF, F<sub>BM</sub></b>	<b>Actual BMC, CBM</b>	<b>Total BMC</b>
<b>Conveyors Continued</b>										
J-1004 A/B	Screw Feeder Drive	2	Power: 0.25 hp	\$ 140	\$ 190	-	-	2.0	\$ 380	\$ -
J-1005 A/B	Screw Feeder	2	Length: 15 m Width: 0.61 m MOC: Carbon Steel	\$2,300	\$3,100	-	-	2.2	\$7,200	\$ 14,000
J-1005 A/B	Screw Feeder Drive	2	Power: 0.25 hp	\$ 140	\$ 190	-	-	2.0	\$ 380	\$ -
<b>Pump</b>										
L-1001 A/B	Feed Pump	2	Power: 0.25 hp Pressure: 140 kPa MOC: Carbon Steel	\$2,100	\$2,900	1.0	1.0	3.4	\$9,900	\$ 20,000
L-1002- L-1004 A/B	Feed Pump	6	Power: 0.25 hp Pressure: 110 kPa MOC: Carbon Steel	\$2,100	\$2,900	1.0	1.0	3.4	\$9,900	\$ 59,000
L-1005- L-1050 A/B	Feed Pump	88	Power: 0.25 hp Pressure: 120 kPa MOC: Carbon Steel	\$2,100	\$2,900	1.0	1.0	3.4	\$9,900	\$870,000

Note: Numbers may not sum to total due to rounding



**Table F2** Capital Cost Summary for Autotrophic Process  
Job Title: Oil Extraction from Autotrophic Microalgae  
Location: Texas

<b>ID#</b>	<b>Equipment Description</b>	<b># of Units</b>	<b>Capacity/Size Specification</b>	<b>PEC Cp 2004</b>	<b>Cp 2016</b>	<b>Material Factor, F<sub>M</sub></b>	<b>Pressure/ Other Factor, F<sub>p</sub></b>	<b>Actual BMF, F<sub>BM</sub></b>	<b>Actual BMC, CBM</b>	<b>Total BMC</b>
<b>Pump Continued</b>										
L-1051 A/B	Feed Pump	2	Power: 0.25 hp Pressure: 110 kPa MOC: Carbon Steel	\$2,100	\$2,900	1.0	1.0	3.4	\$ 9,900	\$19,800
L-1052 A/B	Feed Pump	2	Power: 2.0 hp Pressure: 110 kPa MOC: Carbon Steel	\$4,100	\$5,600	1.0	1.0	3.4	\$19,000	\$38,000
L-1053 A/B	Feed Pump	2	Power: 3.5 hp Pressure: 240 kPa MOC: Carbon Steel	\$5,400	\$7,300	1.0	1.0	3.4	\$25,000	\$50,000
L-1054 A/B	Feed Pump	2	Power: 0.25 hp Pressure: 76 kPa MOC: Carbon Steel	\$2,100	\$2,900	1.0	1.0	3.4	\$10,000	\$20,000
L-1055 A/B	Feed Pump	2	Power: 0.25 hp Pressure: 83 kPa MOC: Carbon Steel	\$2,100	\$2,900	1.0	1.0	3.4	\$10,000	\$20,000
L-1056 A/B	Feed Pump	2	Power: 0.25 hp Pressure: 83 kPa MOC: Carbon Steel	\$2,100	\$2,900	1.0	1.0	3.4	\$10,000	\$20,000

Note: Numbers may not sum to total due to rounding

**Table F2** Capital Cost Summary for Autotrophic Process  
Job Title: Oil Extraction from Autotrophic Microalgae  
Location: Texas

ID#	Equipment Description	# of Units	Capacity/Size Specification	PEC Cp 2004	Cp 2016	Material Factor, F <sub>M</sub>	Pressure/ Other Factor, F <sub>p</sub>	Actual BMF, F <sub>BM</sub>	Actual BMC, CBM	Total BMC
<b>Pump Continued</b>										
L-1057 A/B	Feed Pump	2	Power: 0.25 hp Pressure: 83 kPa MOC: Carbon Steel	\$2,100	\$2,900	1.0	1.0	3.4	\$10,000	\$20,000
L-1058 A/B	Feed Pump	2	Power: 0.25 hp Pressure: 83 kPa MOC: Carbon Steel	\$2,100	\$2,900	1.0	1.0	3.4	\$10,000	\$20,000
L-1059 A/B	Feed Pump	2	Power: 0.25 hp Pressure: 83 kPa MOC: Carbon Steel	\$2,100	\$2,900	1.0	1.0	3.4	\$10,000	\$20,000
L-1060 A/B	Feed Pump	2	Power: 0.25 hp Pressure: 83 kPa MOC: Carbon Steel	\$2,100	\$2,900	1.0	1.0	3.4	\$10,000	\$20,000
L-1061 A/B	Feed Pump	2	Power: 0.25 hp Pressure: 170 kPa MOC: Carbon Steel	\$2,100	\$2,900	1.0	1.0	3.4	\$10,000	\$20,000
L-1062 A/B	Feed Pump	2	Power: 0.25 hp Pressure: 170 kPa MOC: Carbon Steel	\$2,100	\$2,900	1.0	1.0	3.4	\$10,000	\$20,000

Note: Numbers may not sum to total due to rounding

**Table F2** Capital Cost Summary for Autotrophic Process  
Job Title: Oil Extraction from Autotrophic Microalgae  
Location: Texas

<b>ID#</b>	<b>Equipment Description</b>	<b># of Units</b>	<b>Capacity/Size Specification</b>	<b>PEC Cp 2004</b>	<b>Cp 2016</b>	<b>Material Factor, F<sub>M</sub></b>	<b>Pressure/ Other Factor, F<sub>p</sub></b>	<b>Actual BMF, F<sub>BM</sub></b>	<b>Actual BMC, CBM</b>	<b>Total BMC</b>
<b>Pump Continued</b>										
L-1063 A/B	Feed Pump	2	Power: 0.25 hp Pressure: 140 kPa MOC: Carbon Steel	\$2,100	\$2,900	1.0	1.0	3.4	\$10,000	\$20,000
L-1064 A/B	Feed Pump	2	Power: 0.25 hp Pressure: 170 kPa MOC: Carbon Steel	\$2,100	\$2,900	1.0	1.0	3.4	\$10,000	\$20,000
L-1065 A/B	Feed Pump	2	Power: 0.25 hp Pressure: 170 kPa MOC: Carbon Steel	\$2,100	\$2,900	1.0	1.0	3.4	\$10,000	\$20,000
L-1066 A/B	Feed Pump	2	Power: 0.25 hp Pressure: 170 kPa MOC: Carbon Steel	\$2,100	\$2,900	1.0	1.0	3.4	\$10,000	\$20,000
L-1067 A/B	Feed Pump	2	Power: 0.25 hp Pressure: 170 kPa MOC: Carbon Steel	\$2,100	\$2,900	1.0	1.0	3.4	\$10,000	\$20,000
L-1068 A/B	Feed Pump	2	Power: 0.25 hp Pressure: 170 kPa MOC: Carbon Steel	\$2,100	\$2,900	1.0	1.0	3.4	\$10,000	\$20,000

Note: Numbers may not sum to total due to rounding

**Table F2** Capital Cost Summary for Autotrophic Process  
Job Title: Oil Extraction from Autotrophic Microalgae  
Location: Texas

<b>ID#</b>	<b>Equipment Description</b>	<b># of Units</b>	<b>Capacity/Size Specification</b>	<b>PEC Cp 2004</b>	<b>Cp 2016</b>	<b>Material Factor, F<sub>M</sub></b>	<b>Pressure/Other Factor, F<sub>p</sub></b>	<b>Actual BMF, F<sub>BM</sub></b>	<b>Actual BMC, CBM</b>	<b>Total BMC</b>
<b>Pump Continued</b>										
L-1069 A/B	Feed Pump	2	Power: 0.25 hp Pressure: 170 kPa MOC: Carbon Steel	\$2,100	\$2,900	1.0	1.0	3.4	\$10,000	\$20,000
L-1070 A/B	Feed Pump	2	Power: 0.25 hp Pressure: 170 kPa MOC: Carbon Steel	\$2,100	\$2,900	1.0	1.0	3.4	\$10,000	\$20,000
L-1071 A/B	Feed Pump	2	Power: 0.25 hp Pressure: 170 kPa MOC: Carbon Steel	\$2,100	\$2,900	1.0	1.0	3.4	\$10,000	\$20,000
L-1072 A/B	Feed Pump	2	Power: 0.25 hp Pressure: 170 kPa MOC: Carbon Steel	\$2,100	\$2,900	1.0	1.0	3.4	\$10,000	\$20,000
L-1073 A/B	Feed Pump	2	Power: 0.25 hp Pressure: 170 kPa MOC: Carbon Steel	\$2,100	\$2,900	1.0	1.0	3.4	\$10,000	\$20,000
L-1074 A/B	Feed Pump	2	Power: 0.25 hp Pressure: 170 kPa MOC: Carbon Steel	\$2,100	\$2,900	1.0	1.0	3.4	\$10,000	\$20,000

Note: Numbers may not sum to total due to rounding

**Table F2** Capital Cost Summary for Autotrophic Process

Job Title: Oil Extraction from Autotrophic Microalgae

Location: Texas

Page 9 of 12

Basis Date: Oct 2016

ID#	Equipment Description	# of Units	Capacity/Size Specification	PEC Cp 2004	Cp 2016	Material Factor, F <sub>M</sub>	Pressure/ Other Factor, F <sub>p</sub>	Actual BMF, F <sub>BM</sub>	Actual BMC, CBM	Total BMC
<b>Pump Continued</b>										
L-2001-L-2649 A/B	SL Pump	648	Power: 0.25 hp Pressure: 140 kPa MOC: Carbon Steel	\$ 2,100	\$ 2,900	1.0	1.0	3.4	\$ 9,900	\$6,400,000
<b>Photo Bioreactors</b>										
R-1001 A-C	Algae Growth Reactor	3	Diameter: 0.40 m Length: 3.4 m Pressure: 100 kPa MOC: Carbon Steel	\$ 1,500	\$ 2,000	1.0	1.0	3.1	\$ 6,200	\$ 18,600
R-1002-R-1045	Algae Growth Reactor	44	Diameter: 0.40 m Length: 16 m Pressure: 100 kPa MOC: Carbon Steel	\$ 2,900	\$ 3,900	1.0	1.0	3.1	\$12,000	\$ 530,000
R-1046-R-1689	Algae Growth Reactor	644	Diameter: 0.40 m Length: 190 m Pressure: 100 kPa MOC: Carbon Steel	\$13,000	\$18,000	1.0	1.0	3.1	\$ 56,000	\$36,000,000
<b>Tanks</b>										
T-1001 A-C	Holding Tank	3	Height: 7.0 m Diameter: 11 m MOC: Carbon Steel	\$32,000	\$43,000	1.0	1.0	1.9	\$ 82,000	\$ 250,000

Note: Numbers may not sum to total due to rounding

**Table F2** Capital Cost Summary for Autotrophic Process  
Job Title: Oil Extraction from Autotrophic Microalgae  
Location: Texas

<b>ID#</b>	<b>Equipment Description</b>	<b># of Units</b>	<b>Capacity/Size Specification</b>	<b>PEC Cp 2004</b>	<b>Cp 2016</b>	<b>Material Factor, F<sub>M</sub></b>	<b>Pressure/ Other Factor, F<sub>p</sub></b>	<b>Actual BMF, F<sub>BM</sub></b>	<b>Actual BMC, CBM</b>	<b>Total BMC</b>
<b>Tanks Continued</b>										
T-1002	Water Recycle Tank	1	Height: 14 m Diameter: 9.4 m MOC: Carbon Steel	\$2,300	\$3,100	1.0	1.0	2.1	\$ 6,500	\$ 6,500
<b>Evaporators</b>										
V-1001	Evaporator	1	Height: 2.2 m Top Diameter: 0.79 m Bottom Diameter: 0.40 m MOC: Carbon Steel	\$2,900	\$3,900	2.9	1.0	2.9	\$11,000	\$11,000
V-1002	Evaporator	1	Height: 2.2 m Top Diameter: 0.79 m Bottom Diameter: 0.40 m MOC: Carbon Steel	\$2,900	\$3,900	2.9	1.0	2.9	\$11,000	\$11,000
V-1003	Evaporator	1	Height: 2.2 m Top Diameter: 0.79 m Bottom Diameter: 0.40 m MOC: Carbon Steel	\$2,900	\$3,900	2.9	1.0	2.9	\$11,000	\$11,000
V-1004	Evaporator	1	Height: 2.2 m Top Diameter: 0.79 m Bottom Diameter: 0.40 m MOC: Carbon Steel	\$2,900	\$3,900	2.9	1.0	2.9	\$11,000	\$11,000

Note: Numbers may not sum to total due to rounding

**Table F2** Capital Cost Summary for Autotrophic Process  
Job Title: Oil Extraction from Autotrophic Microalgae  
Location: Texas

<b>ID#</b>	<b>Equipment Description</b>	<b># of Units</b>	<b>Capacity/Size Specification</b>	<b>PEC Cp 2004</b>	<b>Cp 2016</b>	<b>Material Factor, F<sub>M</sub></b>	<b>Pressure/Other Factor, F<sub>p</sub></b>	<b>Actual BMF, F<sub>BM</sub></b>	<b>Actual BMC, CBM</b>	<b>Total BMC</b>
<b>Evaporators Continued</b>										
V-1005	Evaporator	1	Height: 2.2 m Top Diameter: 0.79 m Bottom Diameter: 0.40 m MOC: Carbon Steel	\$2,900	\$3,900	2.9	1.0	2.9	\$11,000	\$11,000
V-1006	Evaporator	1	Height: 2.2 m Top Diameter: 0.79 m Bottom Diameter: 0.40 m MOC: Carbon Steel	\$2,900	\$3,900	2.9	1.0	2.9	\$11,000	\$11,000
V-1007	Evaporator	1	Height: 2.2 m Top Diameter: 0.79 m Bottom Diameter: 0.40 m MOC: Carbon Steel	\$2,900	\$3,900	2.9	1.0	2.9	\$11,000	\$11,000
V-1008	Evaporator	1	Height: 2.2 m Top Diameter: 0.79 m Bottom Diameter: 0.40 m MOC: Carbon Steel	\$2,900	\$3,900	2.9	1.0	2.9	\$11,000	\$11,000

Note: Numbers may not sum to total due to rounding

**Table F2** Capital Cost Summary for Autotrophic Process  
Job Title: Oil Extraction from Autotrophic Microalgae  
Location: Texas

ID#	Equipment Description	# of Units	Capacity/Size Specification	PEC Cp 2004	Cp 2016	Material Factor, F <sub>M</sub>	Pressure/ Other Factor, F <sub>p</sub>	Actual BMF, F <sub>BM</sub>	Actual BMC, CBM	Total BMC
<b>Evaporators Continued</b>										
V-1009	Evaporator	1	Height: 2.2 m Top Diameter: 0.79 m Bottom Diameter: 0.40 m MOC: Carbon Steel	\$2,900	\$3,900	2.9	1.0	2.9	\$ 11,000	\$ 11,000
V-1010	Evaporator	1	Height: 2.2 m Top Diameter: 0.79 m Bottom Diameter: 0.40 m MOC: Carbon Steel	\$2,900	\$3,900	2.9	1.0	2.9	\$ 11,000	\$ 11,000
<b>Total Bare Modular Cost</b>									<b>TBM »</b>	\$47,000,000
<b>Contingency and Fee</b>							<b>C<sub>TM</sub></b>	<b>CTBM * 0.18 =</b>	\$ 8,500,000	
<b>Total Module Cost</b>									<b>C<sub>TM</sub> »</b>	\$56,000,000
<b>Auxiliary Facilities</b>							<b>C<sub>AUX</sub></b>	<b>CTM *0.30=</b>	\$17,000,000	
<b>Fixed Capital Investment</b>									<b>FCI »</b>	\$73,000,000
<b>Working Capital</b>							<b>C<sub>wc</sub></b>	<b>FCI*0.15=</b>	\$11,000,000	
<b>Chemicals and Catalysts</b>										\$ 160,000
<b>Total Capital Investment</b>									<b>TCI »</b>	\$84,000,000

Note: Numbers may not sum to total due to rounding



APPENDIX G: CHAPTER 1 INCREMENTAL NPV TABLE

*G.1 Incremental NPV between the Heterotrophic and Autotrophic Processes*

Basis Date: Oct 2016

Year	Net Profit Heterotrophic	Net Profit Autotrophic	Incremental Net Profit	Present Value @15%	Hurdle Rate
-3	\$ -	\$ (15,000,000)	\$ 15,000,000	\$ 30,000,000	0.20
-2	\$ -	\$ (19,000,000)	\$ 19,000,000	\$ 19,000,000	
-1	\$ (2,200,000)	\$ (19,000,000)	\$ 16,800,000	\$ 17,000,000	
0	\$ (11,000,000)	\$ (30,000,000)	\$ 20,000,000	\$ 20,000,000	
1	\$ (900,000)	\$ (150,000,000)	\$ 150,000,000	\$ 130,000,000	
2	\$ (1,000,000)	\$ (150,000,000)	\$ 150,000,000	\$ 100,000,000	
3	\$ (1,000,000)	\$ (150,000,000)	\$ 150,000,000	\$ 87,000,000	
4	\$ (1,100,000)	\$ (150,000,000)	\$ 150,000,000	\$ 72,000,000	
5	\$ (1,100,000)	\$ (150,000,000)	\$ 150,000,000	\$ 60,000,000	
6	\$ (1,100,000)	\$ (150,000,000)	\$ 150,000,000	\$ 50,000,000	
7	\$ (1,200,000)	\$ (150,000,000)	\$ 150,000,000	\$ 42,000,000	
8	\$ (1,200,000)	\$ (150,000,000)	\$ 150,000,000	\$ 35,000,000	
9	\$ (1,200,000)	\$ (150,000,000)	\$ 150,000,000	\$ 29,000,000	
10	\$ (1,200,000)	\$ (150,000,000)	\$ 150,000,000	\$ 24,000,000	
11	\$ (1,200,000)	\$ (150,000,000)	\$ 150,000,000	\$ 20,000,000	
12	\$ (1,200,000)	\$ (150,000,000)	\$ 150,000,000	\$ 17,000,000	
13	\$ (1,200,000)	\$ (150,000,000)	\$ 150,000,000	\$ 14,000,000	
14	\$ (1,200,000)	\$ (150,000,000)	\$ 150,000,000	\$ 12,000,000	
15	\$ (1,200,000)	\$ (150,000,000)	\$ 150,000,000	\$ 10,000,000	
16	\$ (1,200,000)	\$ (150,000,000)	\$ 150,000,000	\$ 8,100,000	
17	\$ (1,200,000)	\$ (150,000,000)	\$ 150,000,000	\$ 6,800,000	
18	\$ (1,400,000)	\$ (150,000,000)	\$ 150,000,000	\$ 5,600,000	
19	\$ (1,400,000)	\$ (150,000,000)	\$ 150,000,000	\$ 4,700,000	
20	\$ 340,000	\$ (140,000,000)	\$ 140,000,000	\$ 3,700,000	
				NPV@HR=	\$ 820,000,000
				DCFROR	N/A

Note: Numbers may not sum to total due to rounding  
 Numbers in parentheses represent negative values

APPENDIX H: CHAPTER 2 HETEROTROPHIC PROCESS DRAWINGS

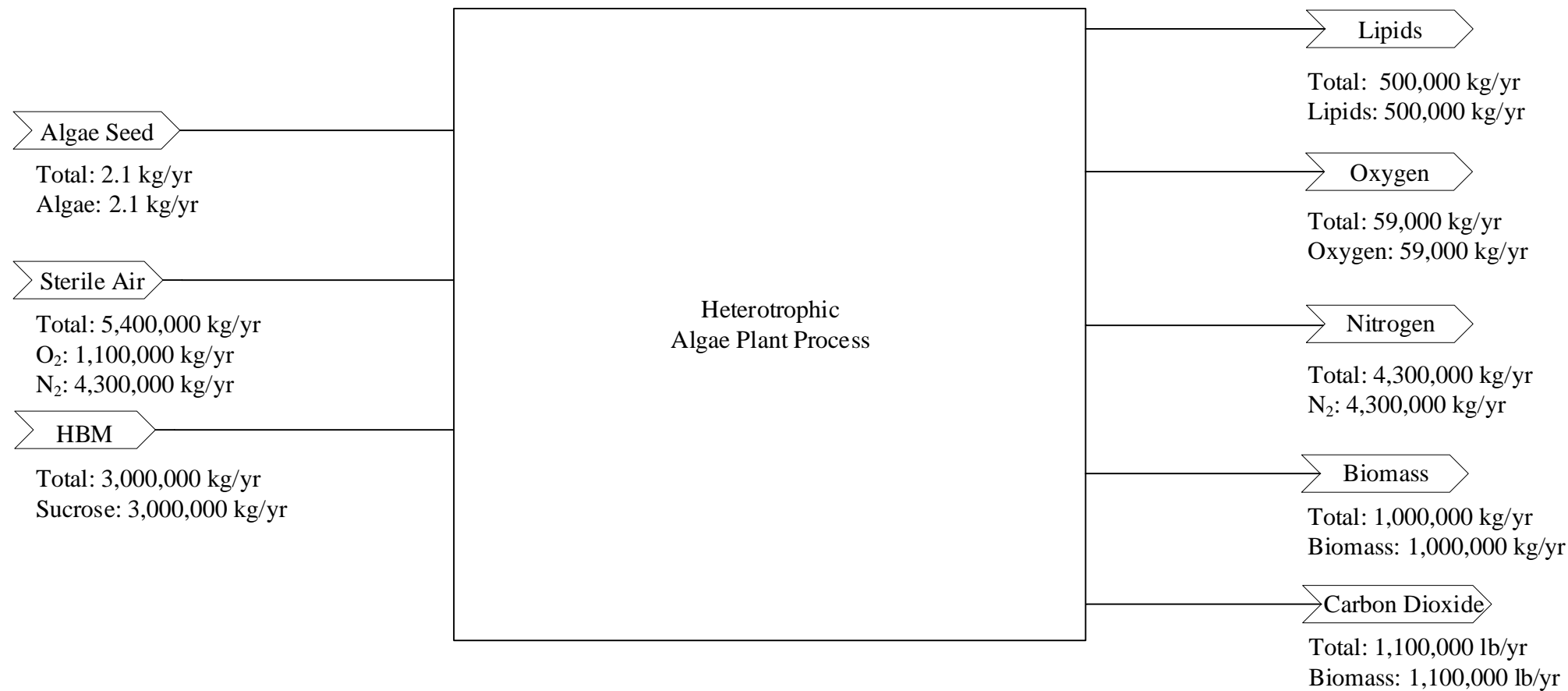

- Notes**
1. Drawing not to scale.
  2. Mass flow rates are in lb/hour.
  3. Mass balance may not sum to total due to rounding.

**Special Symbols / Nomenclature**

 Input/Output

**Reference Drawings:**

- 00-A-001
- 01-A-002
- 02-A-002
- 03-A-002
- 01-A-003
- 02-A-003
- 03-A-003

**Drawing Type**  
I/O Diagram

**Title**  
Drawing H1: Heterotrophic  
Microalgae Oil Extraction

By/Date	DWG #/Sheet #	Rev	Page
JLK 1/22/19	00-A-001/01	0	H-1

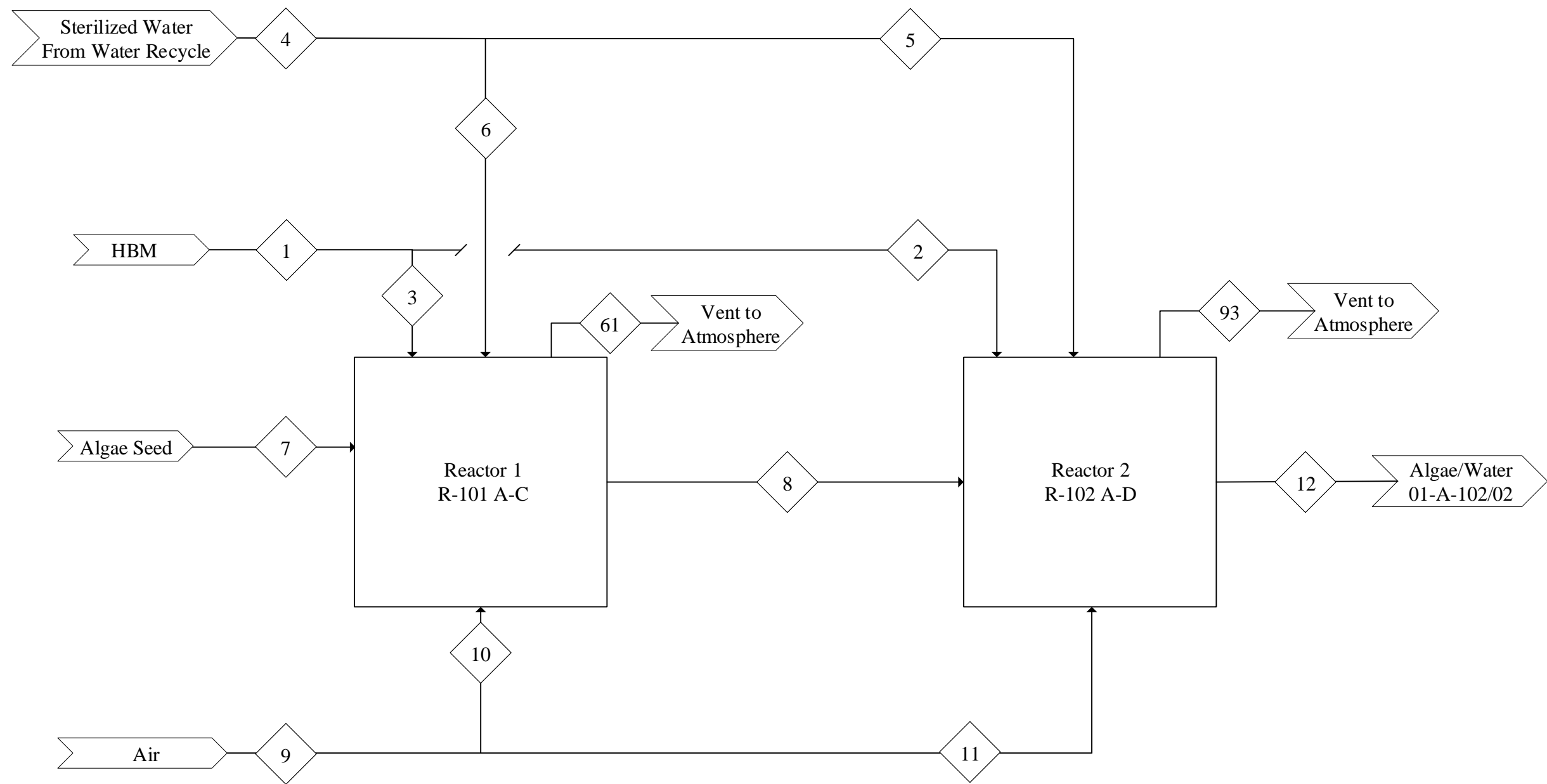

- Notes**
1. Drawings not to scale.
  2. Mass balance may not sum to total due to rounding
  3. 95% of the HBM is consumed during growth
  4. In R-101 A-C, the algae is grown for a period of 15 days
  5. In R-102 A-D, the algae is grown for a period of 15 days
  6. Flow rates are not continuous

**Special Symbols / Nomenclature**

Input/Output  
 Stream Number

- Reference Drawings:**
- 00-A-001
  - 01-A-002
  - 02-A-002
  - 03-A-002
  - 01-A-003
  - 02-A-003
  - 03-A-003

**Drawing Type**

Block Flow Diagram

**Title**

Drawing H2:Heterotrophic Microalgae Oil Extraction

Mass Flow Rates in kg/hr														
Stream	1	2	3	4	5	6	7	8	9	10	11	12	61	93
Water	45000	45000	91	1000000	1000000	2000	4.3	2100	0	0	0	9100	0	0
Biomass	0	0	0	0	0	0	0.059	29	0	0	0	120	0	0
Lipids	0	0	0	0	0	0	0.028	14	0	0	0	59	0	0
HBM	50000	50000	100	2400	2400	4.5	0	5	0	0	0	21	0	0
CO2	0	0	0	0	0	0	0	0	0	0	0	0	0.27	140
Nitrogen	0	0	0	0	0	0	0	0	500	0.95	500	0	0.95	500
Oxygen	0	0	0	0	0	0	0	0	150	0.29	150	0	0.014	7.3
Total	95000	95000	190	1000000	1000000	2000	4.4	2100	700	1.2	700	9300	1.2	650

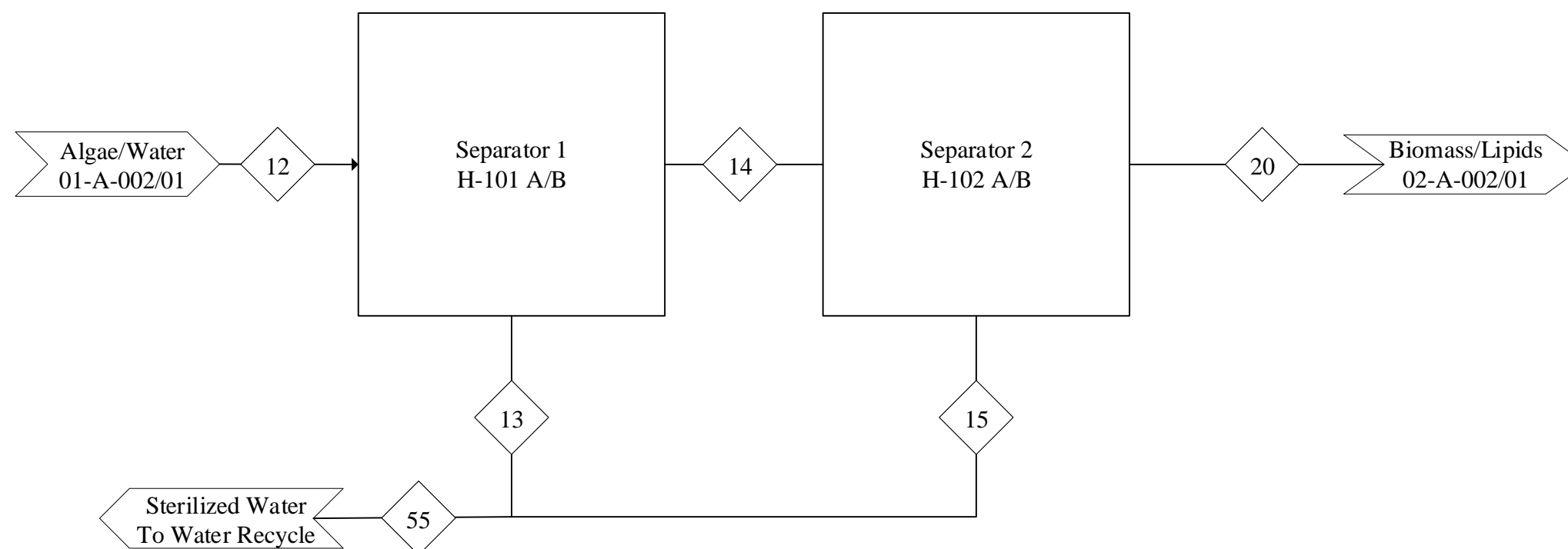

- Notes**
1. Drawings not to scale.
  2. Mass balance may not sum to total due to rounding
  3. In H-101 A/B, the majority of the water is removed
  4. Following H-102 A/B, all the water except what is entrained in the algae is removed.
  5. The water in streams 13 and 15 are combined and recycled.

**Special Symbols / Nomenclature**

- Input/Output
- Stream Number

**Reference Drawings:**

- 00-A-001
- 01-A-002
- 02-A-002
- 03-A-002
- 01-A-003
- 02-A-003
- 03-A-003

**Drawing Type**

Block Flow Diagram

**Title**  
Drawing H3: Heterotrophic  
Microalgae Oil Extraction

Mass Flow Rates in kg/hr						
Stream	12	13	14	15	20	55
Water	9100	9100	41	8.6	9100	9100
Biomass	120	0	120	0	0	0
Lipids	59	0	59	0	0	0
HBM	21	21	0.095	0.02	21	21
Total	9300	9100	220	19	390	9100

By/Date	DWG #/Sheet #	Rev	Page
JLK 1/22/19	02-A-002/02	0	H-3

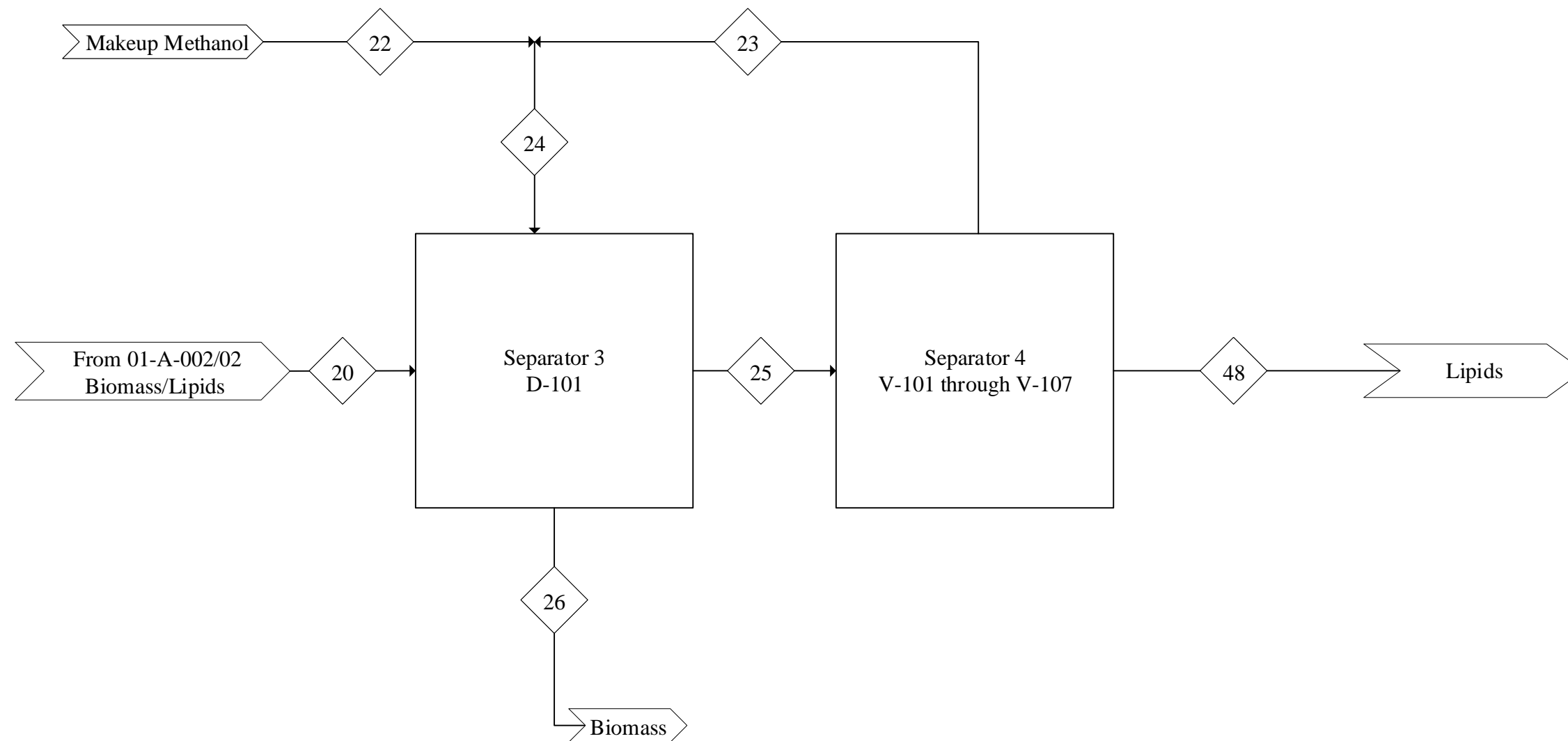

- Notes**
1. Drawings not to scale.
  2. Mass balance may not sum to total due to rounding
  3. In D-101, the lipids are extracted from the biomass
  4. In V-101 through V-107, the methanol is separated from the lipids
  5. The methanol is recycled

**Special Symbols / Nomenclature**

Input/Output  
 Stream Number

**Reference Drawings:**

- 00-A-001
- 01-A-002
- 02-A-002
- 03-A-002
- 01-A-003
- 02-A-003
- 03-A-003

**Drawing Type**  
Block Flow Diagram

**Title**  
Drawing H4: Heterotrophic Microalgae Oil Extraction

By/Date	DWG #/Sheet #	Rev	Page
JLK 1/22/19	03-A-002/02	0	H-4

Mass Flow Rates in kg/hr							
Stream	20	22	23	24	25	26	48
Water	32	0	0	0	32	0.11	Trace
Biomass	120	0	0	0	0	120	0
Lipids	59	0	0	0	59	0.2	59
HBM	0.077	0	Trace	Trace	0.077	Trace	Trace
Methanol	0	73	1300	1300	1300	5	Trace
<b>Total</b>	<b>210</b>	<b>73</b>	<b>1300</b>	<b>1300</b>	<b>1400</b>	<b>130</b>	<b>59</b>

R-101 A-C Microalgae Growth Reactor 1  
 Height: 1.1 m  
 Diameter: 1.6 m

L-101 A-C/D/E/F R-102 Feed Pump  
 Power: 0.25 hp

R-102 A-D Microalgae Growth Reactor 2  
 Height: 8.5 m  
 Diameter: 13 m

L-102 A-D/E/F/G/H Rotary Drum Filter Feed Pump  
 Power: 0.25 hp

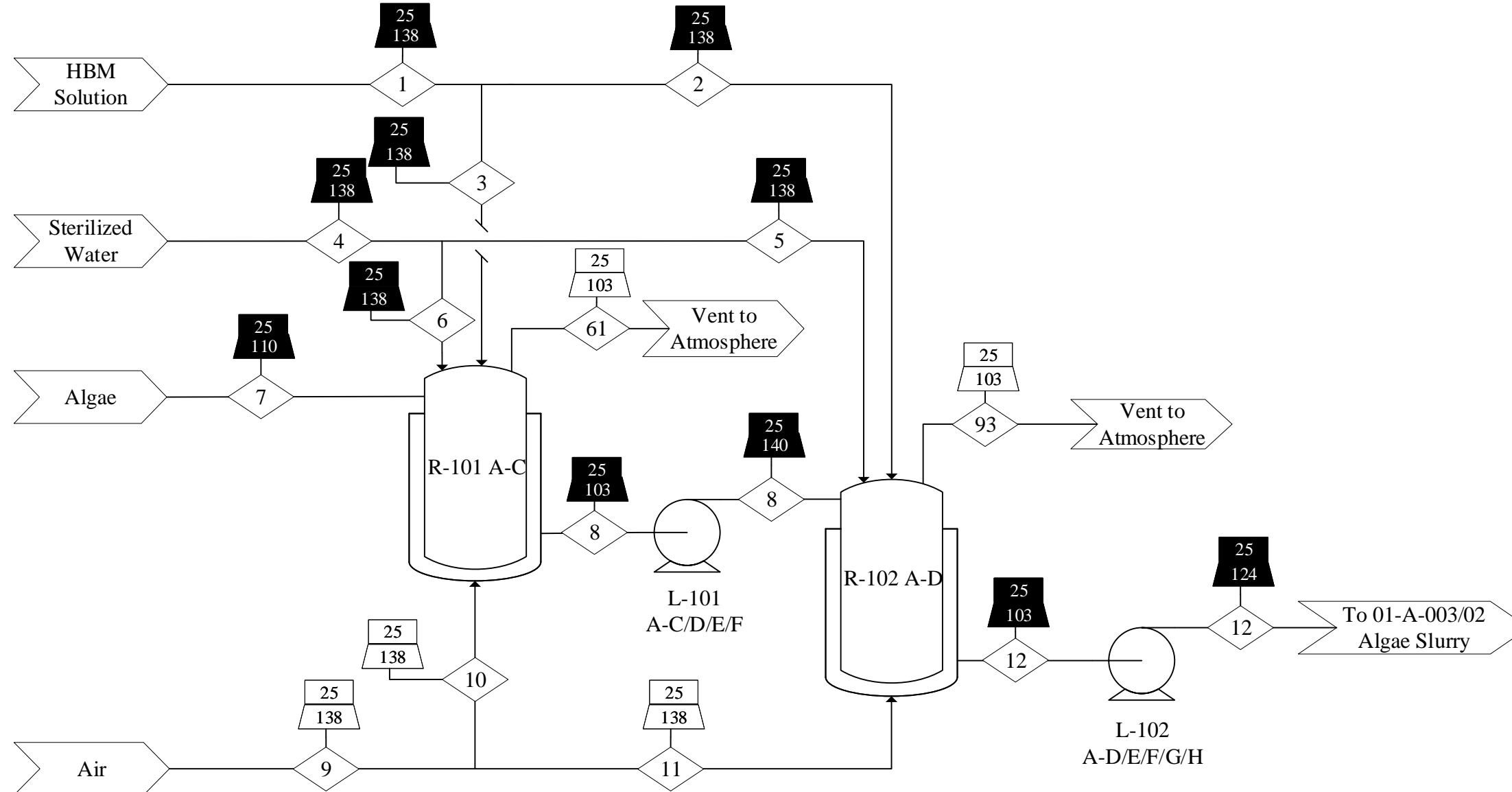

Mass Flow Rates in kg/hr														
Stream	1	2	3	4	5	6	7	8	9	10	11	12	61	93
Water	45000	45000	91	1000000	1000000	2000	4.3	2100	0	0	0	9100	0	0
Biomass	0	0	0	0	0	0	0.059	29	0	0	0	120	0	0
Lipids	0	0	0	0	0	0	0.028	14	0	0	0	59	0	0
HBM	50000	50000	100	2400	2400	4.5	0	5	0	0	0	21	0	0
CO2	0	0	0	0	0	0	0	0	0	0	0	0	0.27	130
Nitrogen	0	0	0	0	0	0	0	0	500	0.95	500	0	0.95	500
Oxygen	0	0	0	0	0	0	0	0	150	0.29	150	0	0.014	7.3
Total	95000	95000	190	1000000	1000000	2000	4.4	2100	650	1.2	650	9300	1.2	640

**Notes**

1. Drawing not to scale.
2. Mass balance may not sum to total due to rounding.
3. Not all mass flow rates are continuous.

**Special Symbols / Nomenclature**

- # Stream Number
- ## Temp (°C), liquid/solid
- ### Pressure (kPa), liquid/solid
- ## Temp (°C), gas
- ### Pressure (kPa), gas
- Input/Output
- HBM Heterotrophic Basal Media

**Reference Drawings:**

- 00-A-001
- 01-A-002
- 02-A-002
- 03-A-002
- 01-A-003
- 02-A-003
- 03-A-003

**Drawing Type**  
 Process Flow Diagram

**Title**  
 Drawing H5: Heterotrophic Microalgae Oil Extraction

By/Date JLK 1/22/19	DWG #/Sheet # 01-A-003/01	Rev 0	Page H-5
---------------------------	------------------------------	----------	-------------



H-101 A/B Rotary Drum Filter Power: 0.50 hp Area: 2.6 m <sup>2</sup>	J-101 A/B Dried Microalgae Transfer Conveyor Length: 15 m Width: 0.61 m Power: 1.0 hp	L-103 A/B Rotary Drum Filter Water Recycle Pump Power: 0.50 hp	H-102 A/B Belt Press Power: 0.50 hp Area: 3.3 m <sup>2</sup>	J-102 A/B Pressed Microalgae Transfer Conveyor Length: 15 m Width: 0.61 m Power: 1.0 hp	C-101 Fine Grinder Capacity: 180 kg/hr Power: 30 hp	J-103 A/B Ground Microalgae Transfer Conveyor Length: 58 m Width: 0.61 m Power: 1.0 hp	L-104 A/B Process Water Recycle Pump Power: 0.75 hp	E-101 A/B Process Water Recycle Sterilizer Area: 28 m <sup>2</sup> Duty: 3.6 MJ/hr	L-105 A/B Belt Press Water Recycle Pump Power: 0.25 hp
---	---	--	---	---	--	--	---	---	--

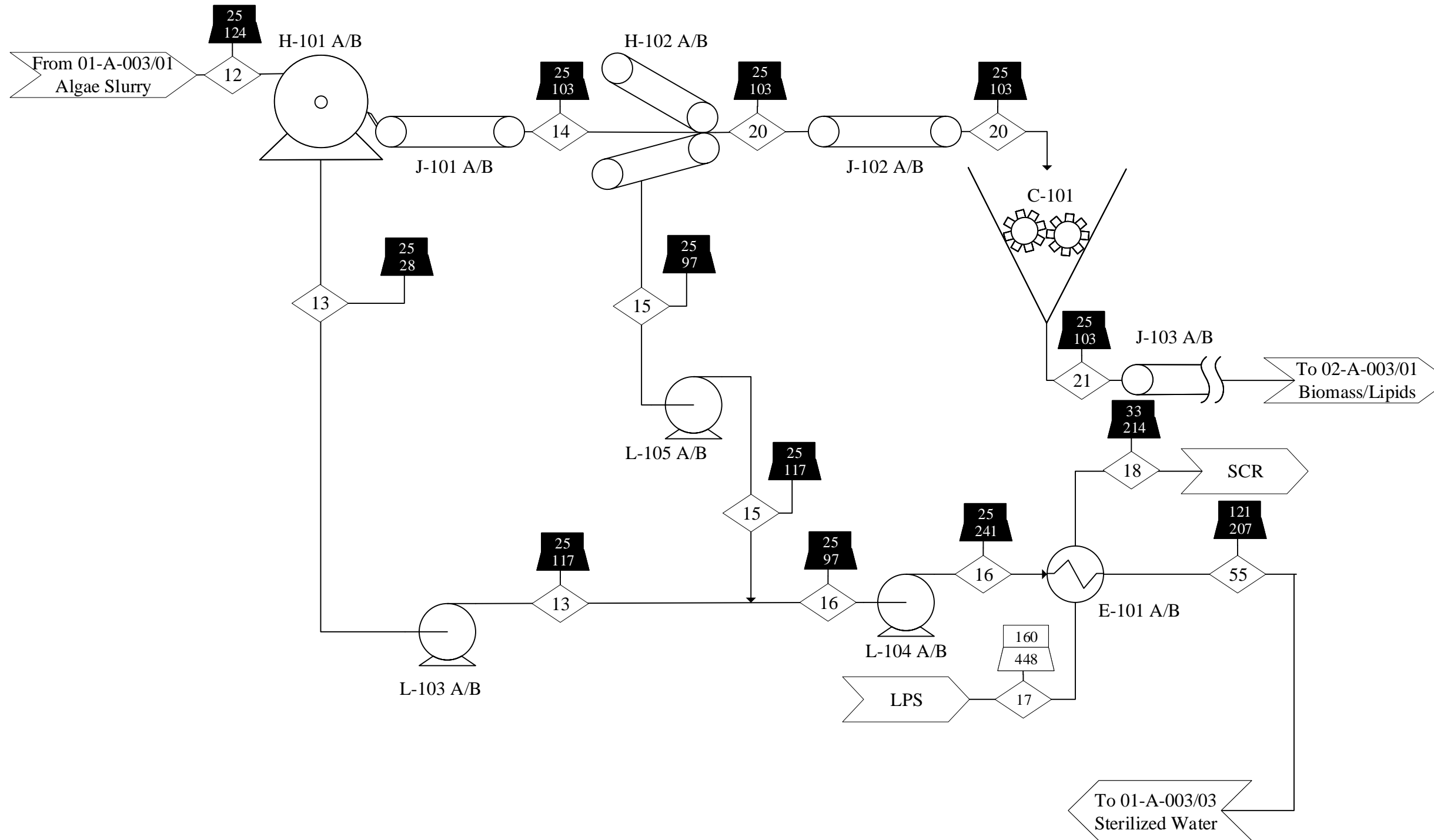

**Notes**

1. Drawing not to scale.
2. Mass balance may not sum to total due to rounding.

**Special Symbols / Nomenclature**

- ◇ # Stream Number
- ## Temp (°C), liquid/solid  
### Pressure (kPa), liquid/solid
- ## Temp (°C), gas  
### Pressure (kPa), gas
- Input/Output
- LPS Low Pressure Steam
- SCR Steam Condensate Return

**Reference Drawings:**

- 00-A-001
- 01-A-002
- 02-A-002
- 03-A-002
- 01-A-003
- 02-A-003
- 03-A-003

**Drawing Type**  
Process Flow Diagram

**Title**  
Drawing H6: Heterotrophic Microalgae Oil Extraction

Mass Flow Rates in kg/hr										
Stream	12	13	14	15	16	17	18	55	20	21
Water	9100	9100	41	8.6	9100	1400	1400	9100	32	32
Biomass	120	0	120	0	0	0	0	0	120	120
Lipids	59	0	59	0	0	0	0	0	59	59
HBM	21	21	0.095	0.02	21	0	0	21	0.077	0.077
Total	9300	9100	220	8.6	9000	1400	1400	9100	210	210

E-106 A/B  
Process Water  
Recycle Cooler  
Area: 28 m<sup>2</sup>  
Duty: 3.7 MJ/hr

T-101  
Process Water  
Recycle Holding Tank  
Height: 12 m  
Diameter: 19 m

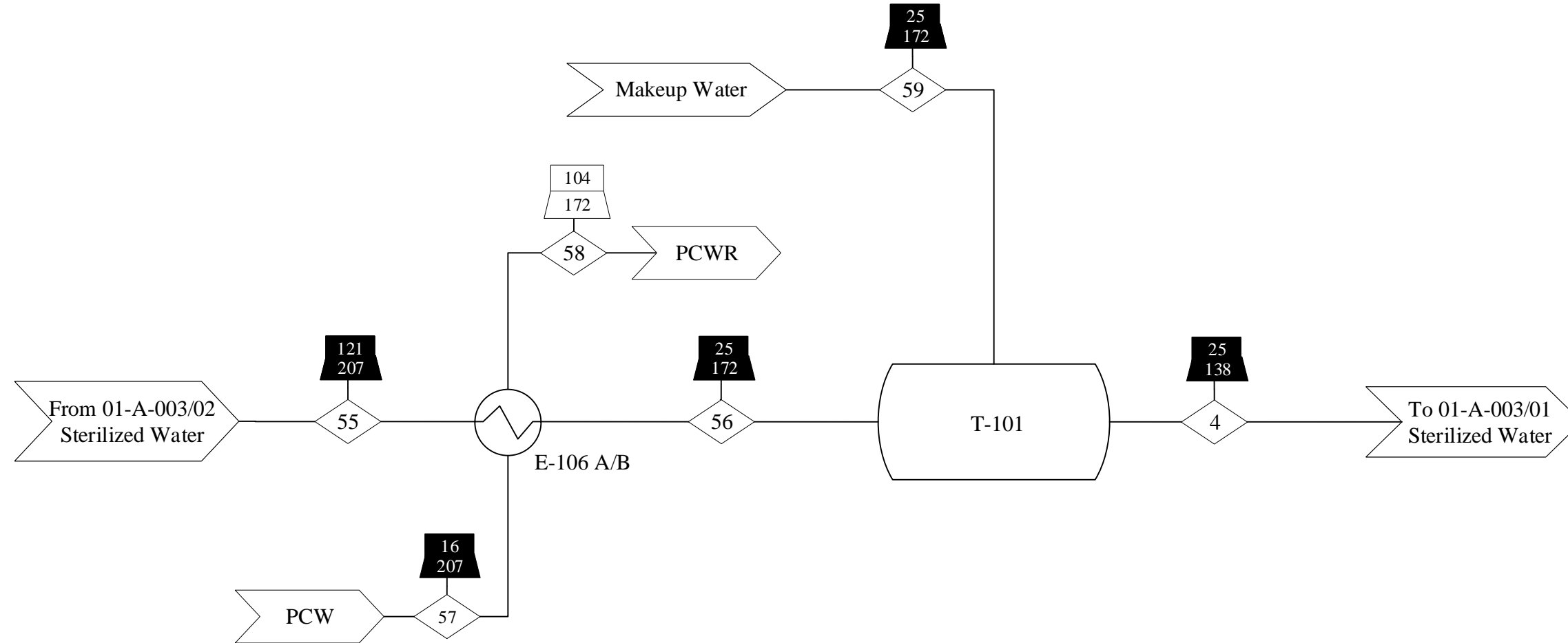

- Notes**
1. Drawing not to scale.
  2. Mass balance may not sum to total due to rounding.
  3. Not all mass flow rates are continuous.

- Special Symbols / Nomenclature**
- ◇ # Stream Number
  - ## Temp (°C), liquid/solid
  - ### Pressure (kPa), liquid/solid
  - ## Temp (°C), gas
  - ### Pressure (kPa), gas
  - ▭ Input/Output
  - ▭ PCW Process Cooling Water
  - ▭ PCWR Process Cooling Water Return

- Reference Drawings:**
- 00-A-001
  - 01-A-002
  - 02-A-002
  - 03-A-002
  - 01-A-003
  - 02-A-003
  - 03-A-003

**Drawing Type**  
Process Flow Diagram

**Title**  
Drawing H7: Heterotrophic Microalgae Oil Extraction

By/Date	DWG #/ Sheet #	Rev	Page
JLK 1/22/19	02-A-003/02	0	H-7

Mass Flow Rates in kg/hr						
Stream	4	55	56	57	58	59
Water	1000000	9100	9100	1400	1400	450
Biomass	0	0	0	0	0	0
Lipids	0	0	0	0	0	0
HBM	2400	21	21	0	0	0
Total	1000000	9100	9100	1400	1400	450

J-103 A/B Ground Microalgae Transfer Conveyor Length: 58 m Width: 0.61 m Power: 1.0 hp	J-104 A/B Ground Microalgae Transfer Screw Feeder Length: 4.6 m Diameter: 0.10 m Power: 0.25 hp	D-101 Leacher Height: 2.5 m Diameter: 3.7 m Mixer Power: 36 hp	D-102 Methanol Surge Drum Height: 1.9 m Diameter: 0.82 m	J-105 A/B Biomass Product Transfer Extruder Length: 4.6 m Diameter: 0.10 m Power: 0.25 hp	J-106 A/B Biomass Product Transfer Conveyor Length: 94 m Width: 0.61 m Power: 1.0 hp
---	--	--	--	--	---

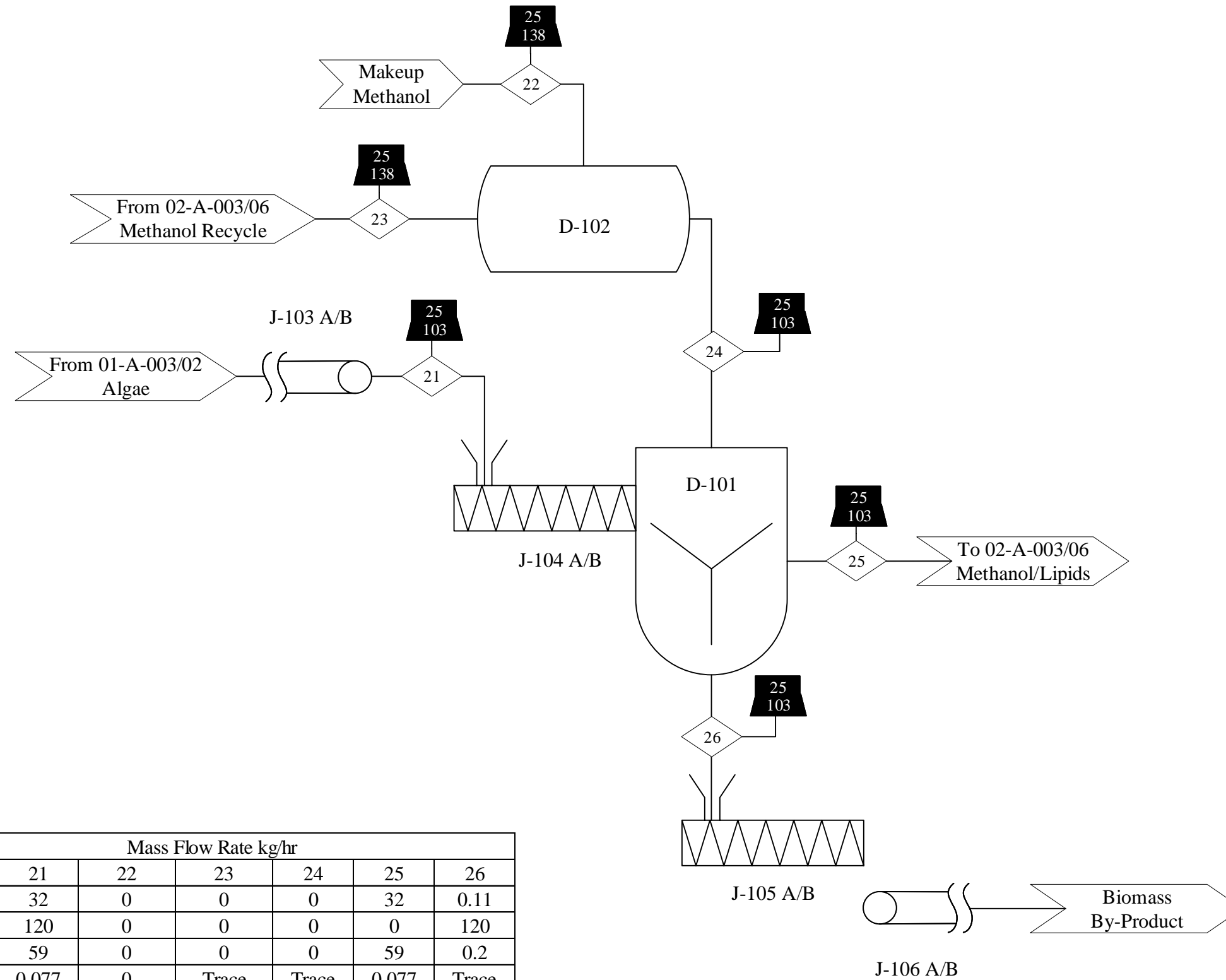

Mass Flow Rate kg/hr						
Stream	21	22	23	24	25	26
Water	32	0	0	0	32	0.11
Biomass	120	0	0	0	0	120
Lipids	59	0	0	0	59	0.2
HBM	0.077	0	Trace	Trace	0.077	Trace
Methanol	0	73	1300	1400	1400	5
Total	210	73	1300	1400	1500	130

**Notes**

1. Drawing not to scale.
2. Mass flow rates are in lb/hour.
3. Mass balance may not sum to total due to rounding.

**Special Symbols / Nomenclature**

# Stream Number

## Temp (°C), liquid/solid

### Pressure (kPa), liquid/solid

Input/Output

**Reference Drawings:**

- 00-A-001
- 01-A-002
- 02-A-002
- 03-A-002
- 01-A-003
- 02-A-003
- 03-A-003

**Drawing Type**

Process Flow Diagram

**Title**

Drawing H8: Heterotrophic Microalgae Oil Extraction

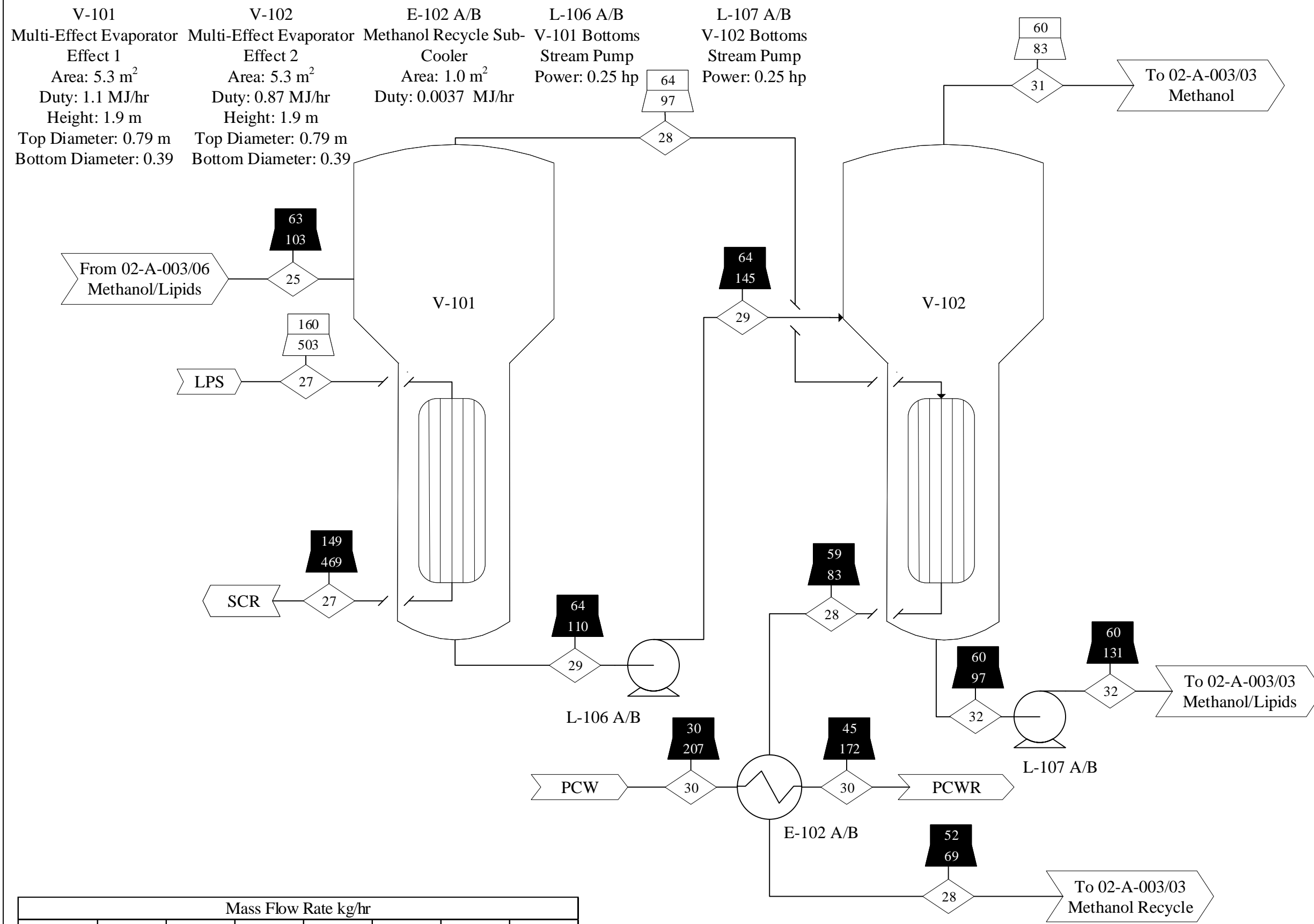

**Notes**

1. Drawing not to scale.
2. Mass flow rates are in lb/hour.
3. Mass balance may not sum to total due to rounding.

**Special Symbols / Nomenclature**

- # Stream Number
- ## Temp (°C), gas
- ### Pressure (kPa), gas
- ## Temp (°C), liquid/solid
- ### Pressure (kPa), liquid/solid
- Input/Output
- PCW Process Cooling Water
- PCWR Process Cooling Water Return
- LPS Low Pressure Steam
- SCR Steam Condensate Return

**Reference Drawings:**

- 00-A-001
- 01-A-002
- 02-A-002
- 03-A-002
- 01-A-003
- 02-A-003
- 03-A-003

**Drawing Type**  
Process Flow Diagram

**Title**  
Drawing H9: Heterotrophic Microalgae Oil Extraction

Mass Flow Rate kg/hr							
Stream	25	27	28	29	30	31	32
Lipids	59	0	Trace	59	0	Trace	59
Methanol	1400	0	200	1200	0	200	1000
HBM	0.077	0	Trace	0.077	0	Trace	0.077
Water	32	100	Trace	32	59	Trace	32
<b>Total</b>	<b>1500</b>	<b>100</b>	<b>200</b>	<b>1300</b>	<b>59</b>	<b>200</b>	<b>1100</b>

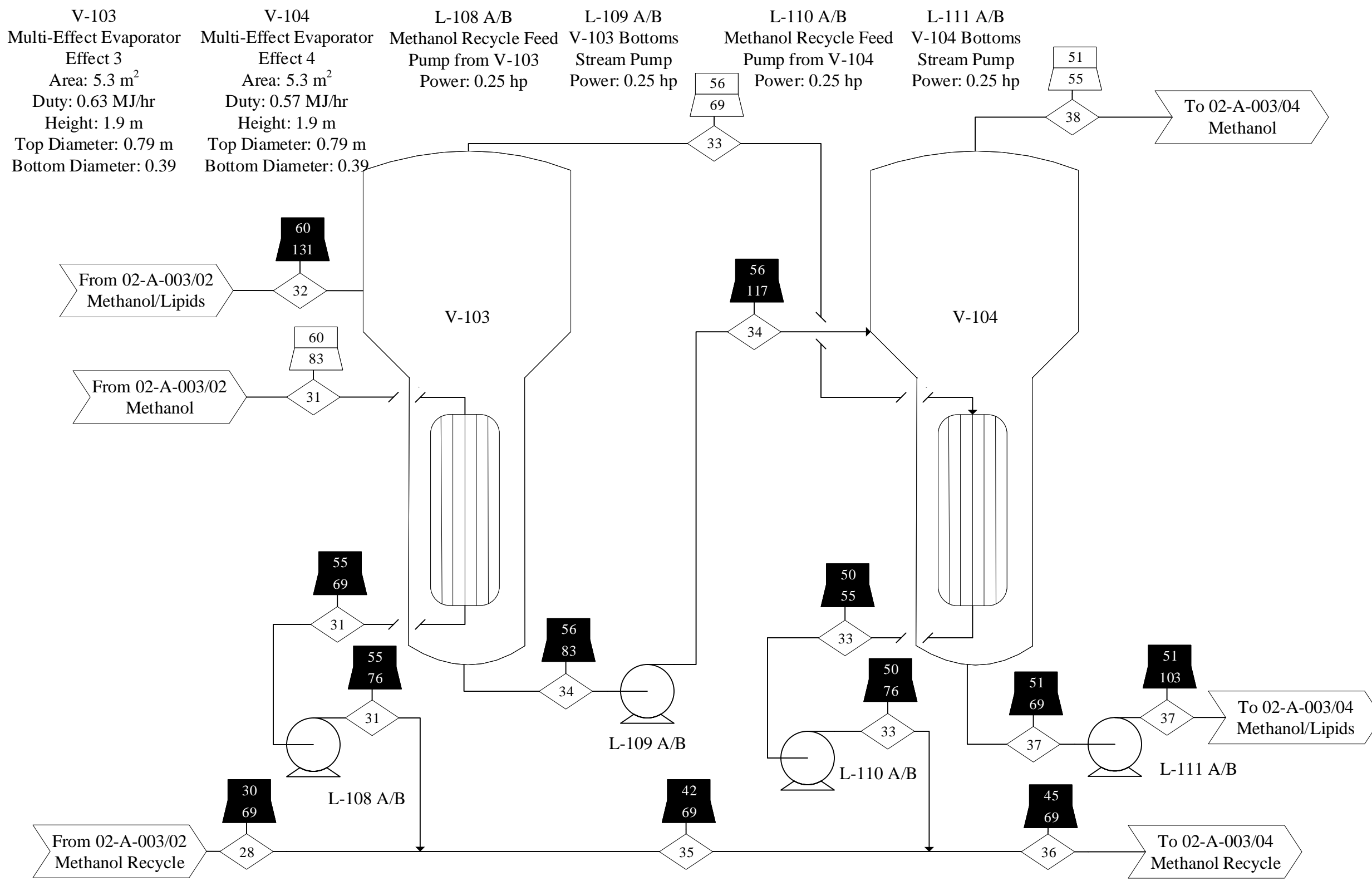

**Notes**

1. Drawing not to scale.
2. Mass flow rates are in lb/hour.
3. Mass balance may not sum to total due to rounding.

**Special Symbols / Nomenclature**

- # Stream Number
- ## Temp (°C), gas
- ### Pressure (kPa), gas
- ## Temp (°C), liquid/solid
- ### Pressure (kPa), liquid/solid
- Input/Output

**Reference Drawings:**

- 00-A-001
- 01-A-002
- 02-A-002
- 03-A-002
- 01-A-003
- 02-A-003
- 03-A-003

**Drawing Type**  
Process Flow Diagram

**Title**  
Drawing H10: Heterotrophic Microalgae Oil Extraction

By/Date JLK 1/22/19	DWG #/ Sheet # 03-A-003/03	Rev 0	Page H-10
---------------------------	-------------------------------	----------	--------------

Mass Flow Rate kg/hr									
Stream	28	31	32	33	34	35	36	37	38
Lipids	Trace	Trace	59	Trace	59	Trace	Trace	59	Trace
Methanol	200	200	1000	200	820	410	590	590	200
HBM	Trace	Trace	0.077	Trace	0.077	Trace	Trace	0.077	Trace
Water	Trace	Trace	32	Trace	32	Trace	Trace	32	Trace
<b>Total</b>	<b>200</b>	<b>200</b>	<b>1100</b>	<b>200</b>	<b>910</b>	<b>410</b>	<b>590</b>	<b>680</b>	<b>200</b>

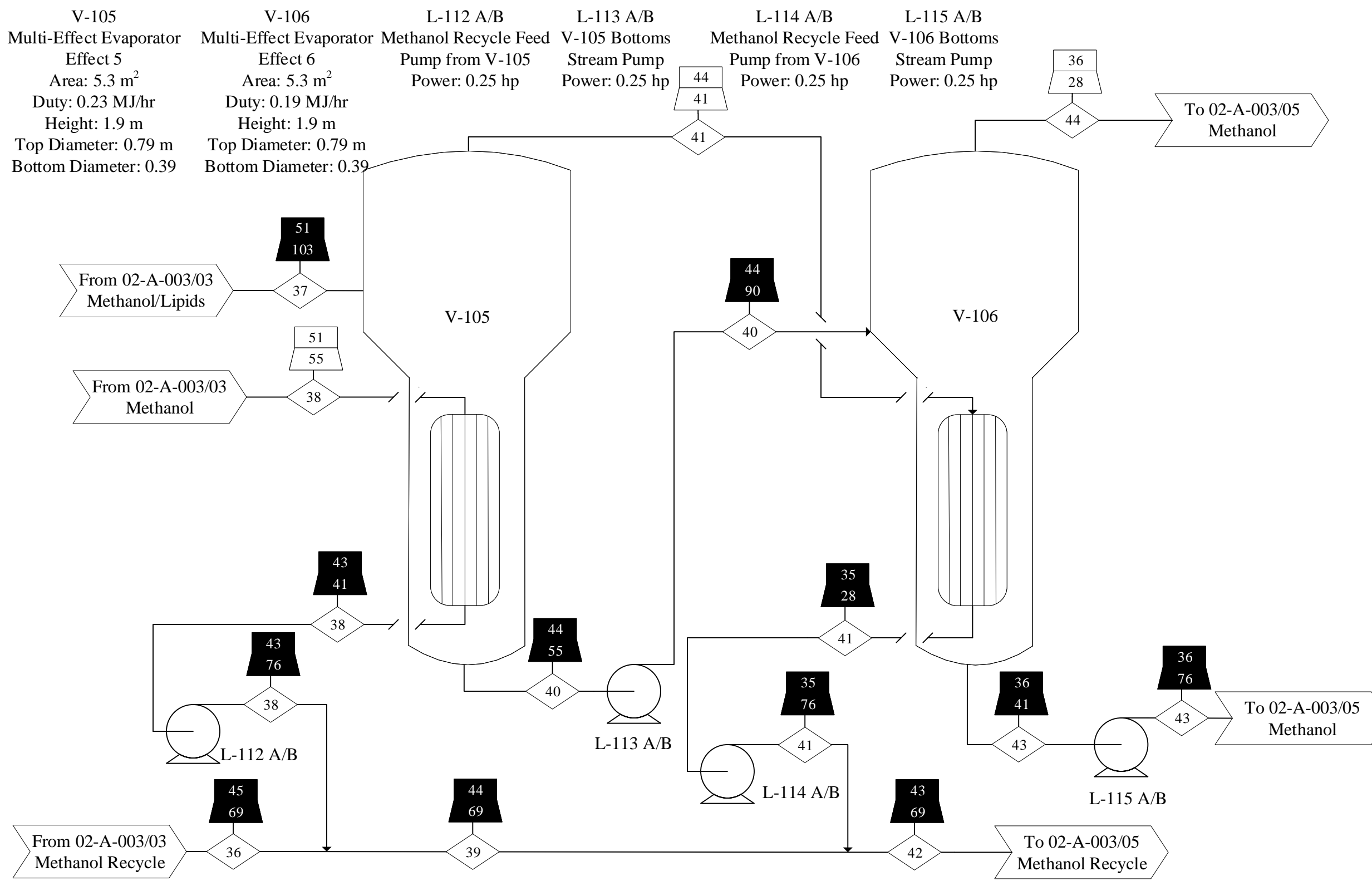

Mass Flow Rate kg/hr									
Stream	36	37	38	39	40	41	42	43	44
Lipids	Trace	59	Trace	Trace	59	Trace	Trace	59	Trace
Methanol	590	590	200	820	410	200	1000	210	200
HBM	Trace	0.077	Trace	Trace	0.077	Trace	Trace	0.077	Trace
Water	Trace	32	Trace	Trace	32	Trace	Trace	32	Trace
Total	590	680	200	820	500	200	1000	300	200

**Notes**

1. Drawing not to scale.
2. Mass flow rates are in lb/hour.
3. Mass balance may not sum to total due to rounding.

**Special Symbols / Nomenclature**

- # Stream Number
- ## Temp (°C), gas
- ### Pressure (kPa), gas
- ## Temp (°C), liquid/solid
- ### Pressure (kPa), liquid/solid
- Input/Output

**Reference Drawings:**

- 00-A-001
- 01-A-002
- 02-A-002
- 03-A-002
- 01-A-003
- 02-A-003
- 03-A-003

**Drawing Type**  
Process Flow Diagram

**Title**  
Drawing H11: Heterotrophic Microalgae Oil Extraction

By/Date	DWG #/ Sheet #	Rev	Page
JLK 1/22/19	03-A-003/04	0	H-11

V-107  
Multi-Effect Evaporator  
Effect 7  
Area: 5.3 m<sup>2</sup>  
Duty: 0.051 MJ/hr  
Height: 1.9 m  
Top Diameter: 0.79 m  
Bottom Diameter: 0.39

L-116 A/B  
Methanol Recycle Feed  
Pump from V-107  
Power: 0.25 hp

L-117 A/B  
Lipid Product  
Feed Pump  
Power: 0.25 hp

L-118 A/B  
Methanol/Water  
Waste Treatment  
Feed Pump  
Power: 0.25 hp

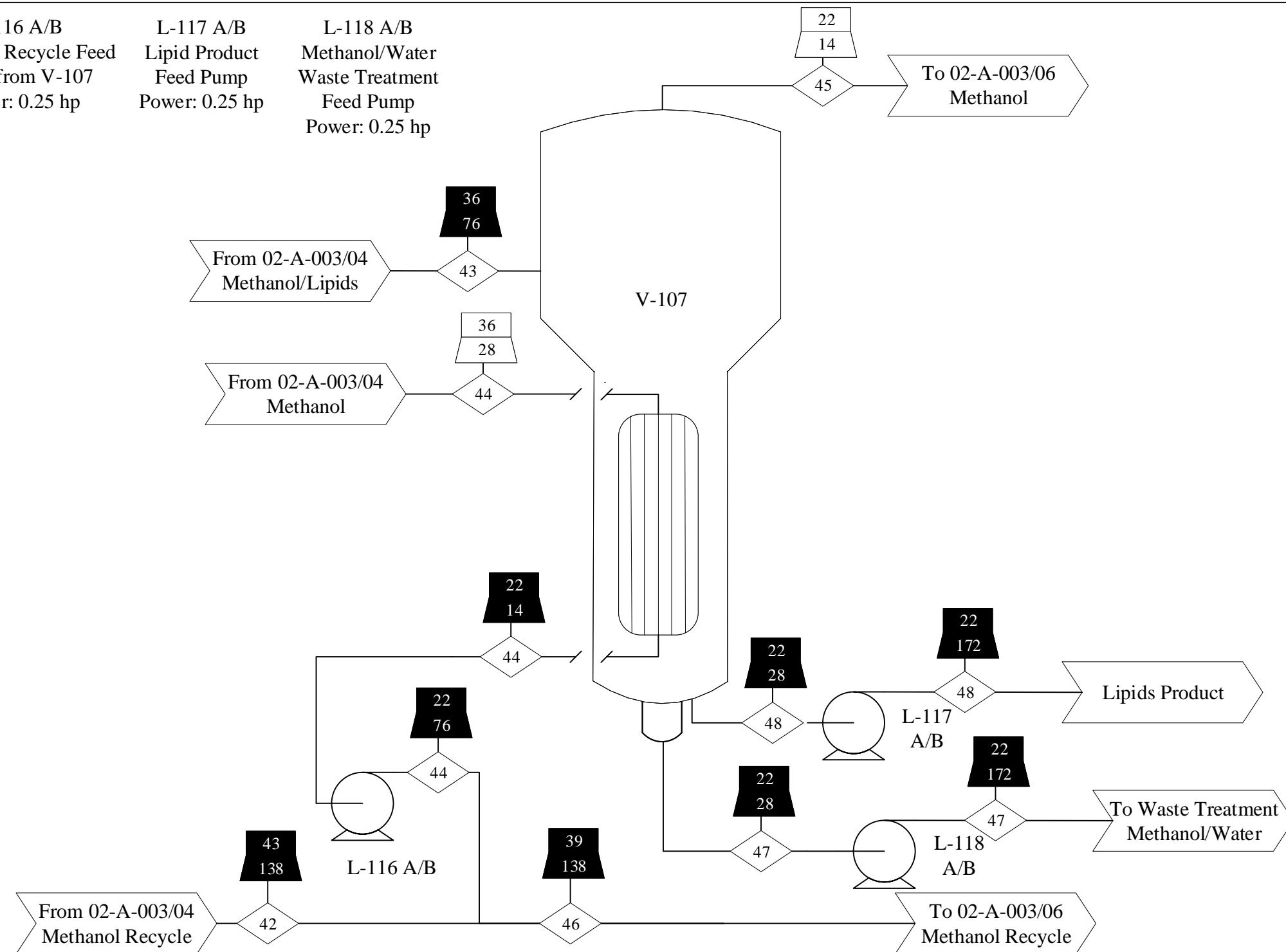

**Notes**

1. Drawing not to scale.
2. Mass flow rates are in lb/hour.
3. Mass balance may not sum to total due to rounding.

**Special Symbols / Nomenclature**

- ◇ # Stream Number
- ## Temp (°C), gas
- ### Pressure (kPa), gas
- ## Temp (°C), liquid/solid
- ### Pressure (kPa), liquid/solid
- ▭ Input/Output
- PCW Process Cooling Water
- PCWR Process Cooling Water Return

**Reference Drawings:**

- 00-A-001
- 01-A-002
- 02-A-002
- 03-A-002
- 01-A-003
- 02-A-003
- 03-A-003

**Drawing Type**  
Process Flow Diagram

**Title**  
Drawing H12: Heterotrophic  
Microalgae Oil Extraction

By/Date JLK 1/22/19	DWG #/ Sheet # 03-A-003/05	Rev 0	Page H-12
---------------------------	-------------------------------	----------	--------------

Mass Flow Rate kg/hr							
Stream	42	43	44	45	46	47	48
Lipids	Trace	59	Trace	Trace	Trace	Trace	59
Methanol	1000	210	200	190	1200	17	Trace
HBM	Trace	0.077	Trace	Trace	Trace	0.077	Trace
Water	Trace	32	Trace	Trace	Trace	32	Trace
Total	1000	300	200	190	1200	49	59



E-103 A/B V-107 Methanol Recycle/ V-101 Feed Cross Exchanger Area: 5.6 m <sup>2</sup> Duty: 0.14 MJ/hr	E-104 A/B V-107 Methanol Recycle Condenser Area: 1.0 m <sup>2</sup> Duty: 0.0037 MJ/hr	E-105 A/B Methanol Surge Drum Pre-Cooler Area: 5.9 m <sup>2</sup> Duty: 0.057 MJ/hr	L-119 A/B Lipid/Methanol Cross Exchanger Feed Pump Power: 0.25 hp	L-120 A/B Total Methanol Recycle Pump Power: 0.25 hp	G-101 V-107 Methanol Recycle Compressor Stages: 1 Power: 26 hp
---	--	---	---	---	--

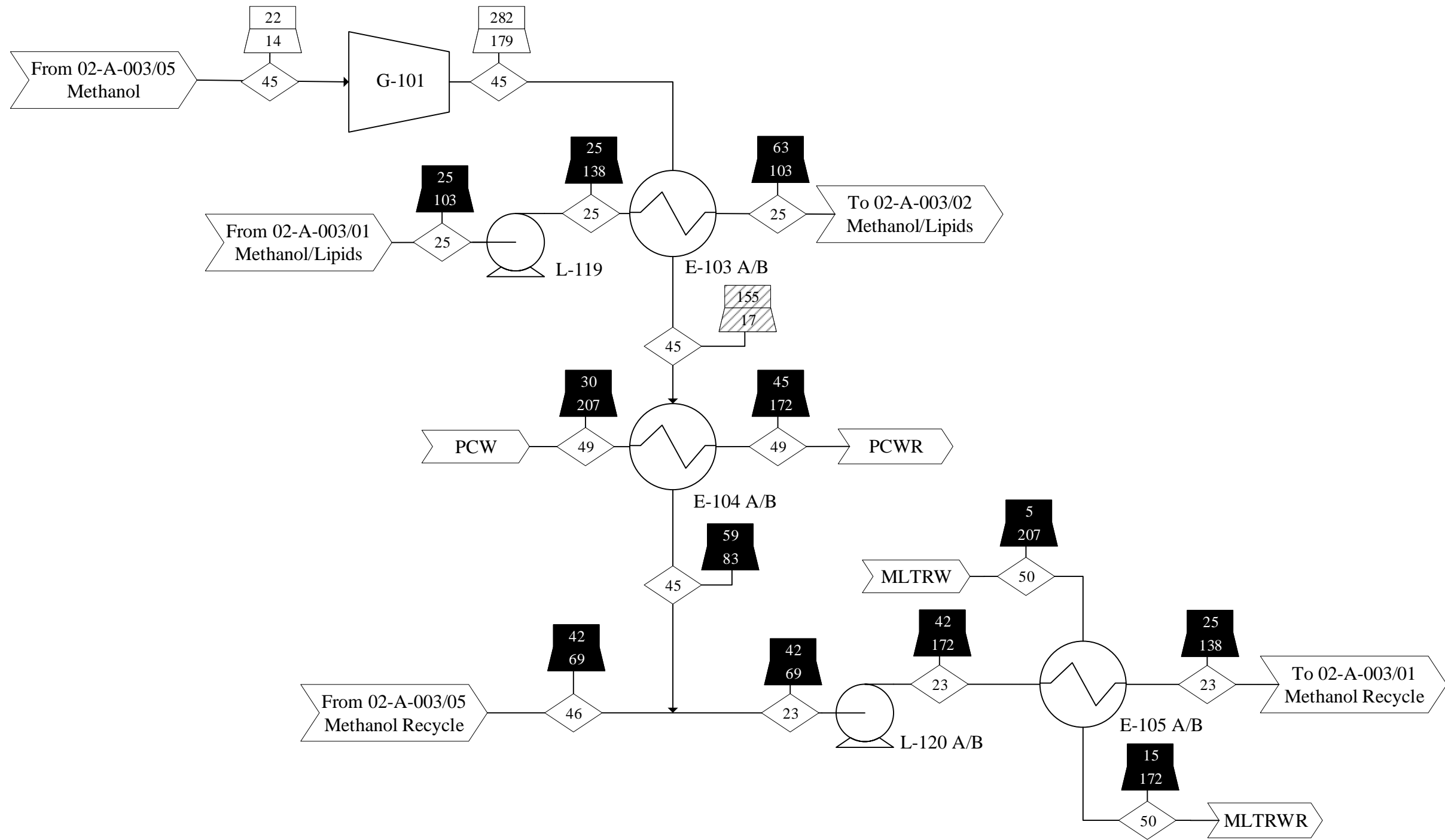

**Notes**

- Drawing not to scale.
- Mass flow rates are in lb/hour.
- Mass balance may not sum to total due to rounding.

**Special Symbols / Nomenclature**

- # Stream Number
- ## Temp (°C), gas
- ### Pressure (kPa), gas
- ## Temp (°C), liquid/solid
- ### Pressure (kPa), liquid/solid
- ## Temp (°C), Mixed
- ### Phase
- ### Pressure (kPa), Mixed
- Phase
- Input/Output
- PCW Process Cooling Water
- PCWR Process Cooling Water Return
- MLTRW Moderately Low Temp Refrigerated Water
- MLTRWR Moderately Low Temp Refrigerated Water Return

**Reference Drawings:**

- 00-A-001
- 01-A-002
- 02-A-002
- 03-A-002
- 01-A-003
- 02-A-003
- 03-A-003

**Drawing Type**  
Process Flow Diagram

**Title**  
Drawing H13: Heterotrophic Microalgae Oil Extraction

Mass Flow Rate kg/hr						
Stream	23	25	45	46	49	50
Lipids	Trace	59	Trace	Trace	0	0
Methanol	1400	1400	190	1200	0	0
HBM	Trace	0.077	Trace	Trace	0	0
Water	Trace	32	Trace	Trace	2000	1400
Total	1400	1500	190	1200	2000	1400



APPENDIX I: CHAPTER 2 AUTOTROPHIC PROCESS DRAWINGS

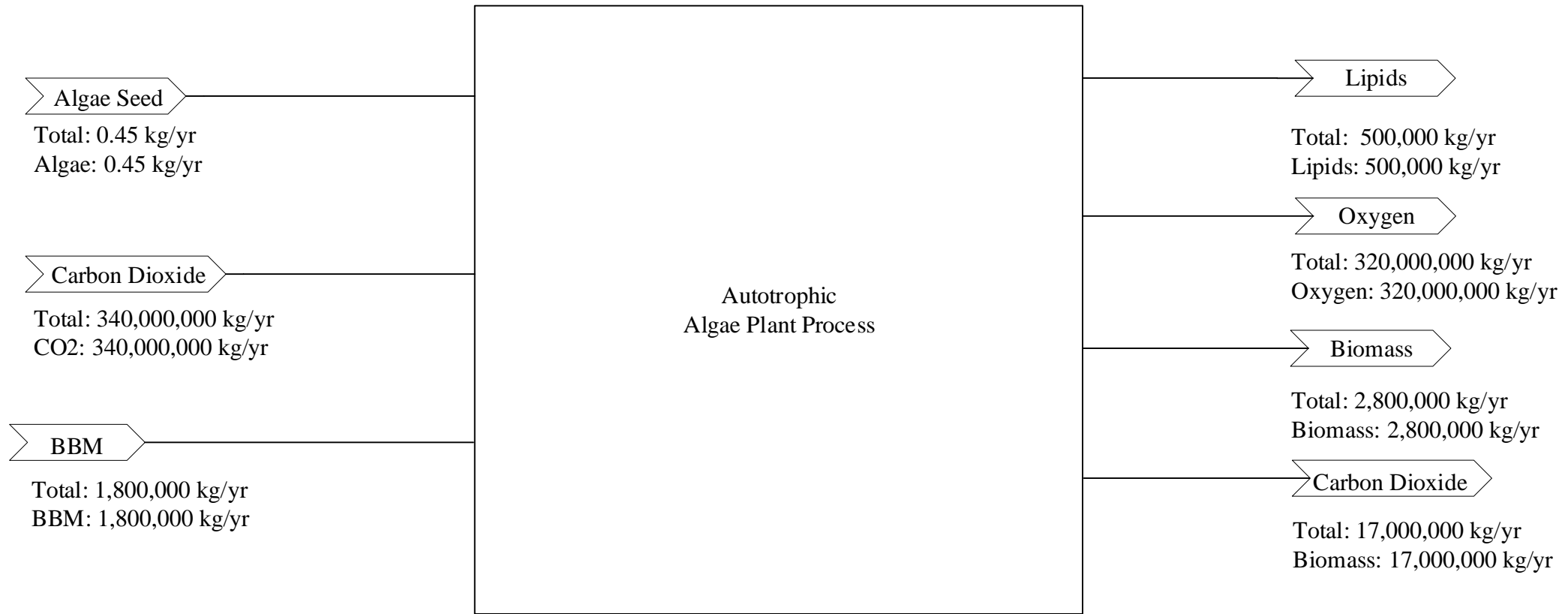

**Notes**

1. Drawing not to scale.
2. Mass flow rates are in lb/hour.
3. Mass balance may not sum to total due to rounding.

**Special Symbols / Nomenclature**

 Input/Output

**Reference Drawings:**

- 00-A-101
- 01-A-102
- 02-A-102
- 03-A-102
- 01-A-103
- 02-A-103
- 03-A-103

**Drawing Type**  
I/O Diagram

**Title**  
Drawing I1: Autotrophic  
Microalgae Oil Extraction

By/Date	DWG #/Sheet #	Rev	Page
JLK 1/22/19	00-A-101/01	0	I-1

- Notes**
1. Drawings not to scale.
  2. Mass balance may not sum to total due to rounding
  3. 95% of the BBM is consumed during growth
  4. In R-1001 A-C, the algae is grown for a period of 14 days
  5. In R-1002 through R-1045 the algae is grown for a period of 14 days
  6. In R-1046 through R-1689, the algae is grown for a period of 14 days
  7. Not all flow rates are continuous

**Special Symbols / Nomenclature**

 Input/Output

 Stream Number

 Bolds Basal Media

**Reference Drawings:**

- 00-A-101
- 01-A-102
- 02-A-102
- 03-A-102
- 01-A-103
- 02-A-103
- 03-A-103

**Drawing Type**

Block Flow Diagram

**Title**

Drawing I2: Autotrophic Microalgae Oil Extraction

By/Date	DWG #/Sheet #	Rev	Page
JLK 1/22/19	01-A-102/01	0	I-2

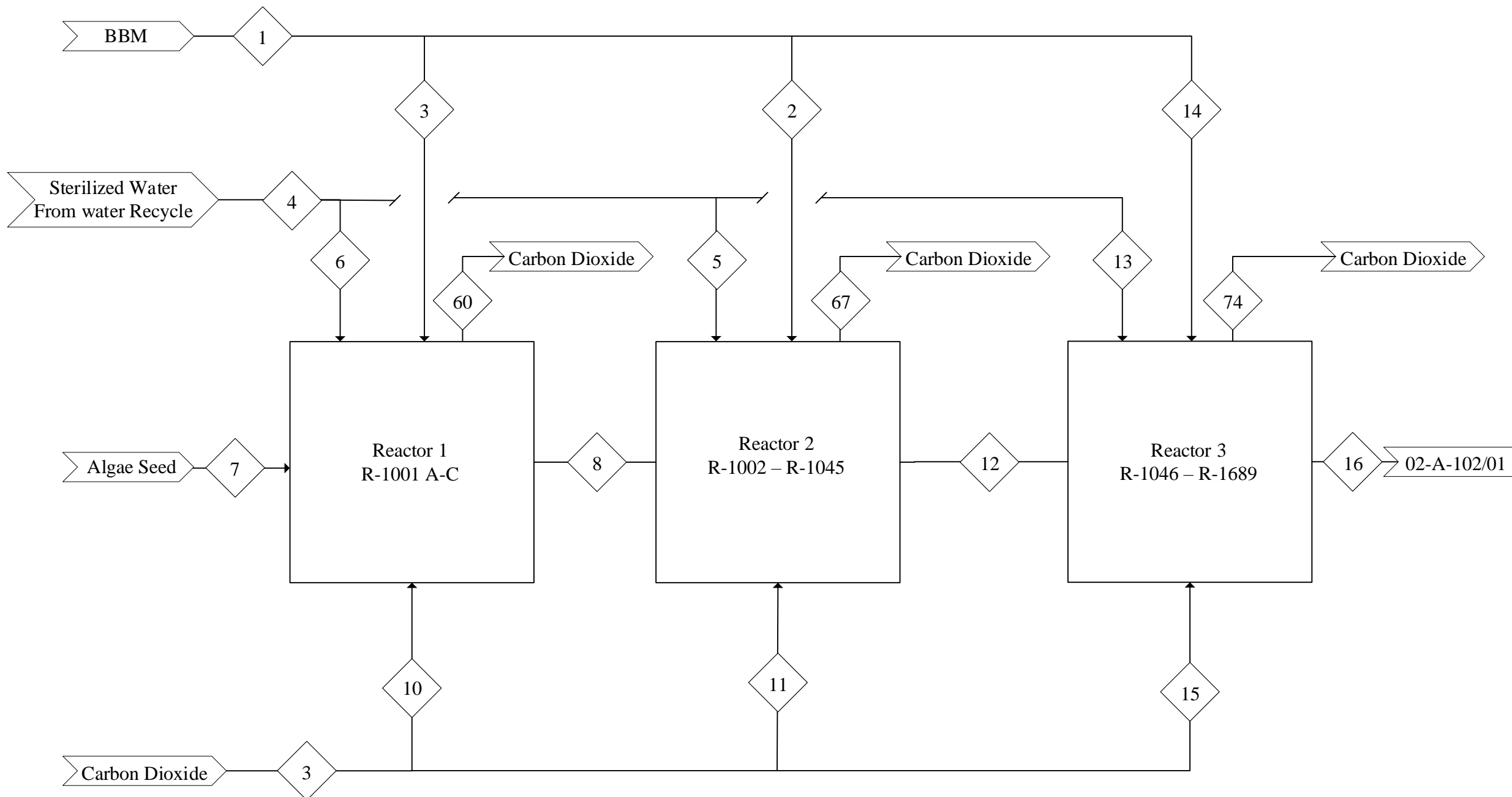

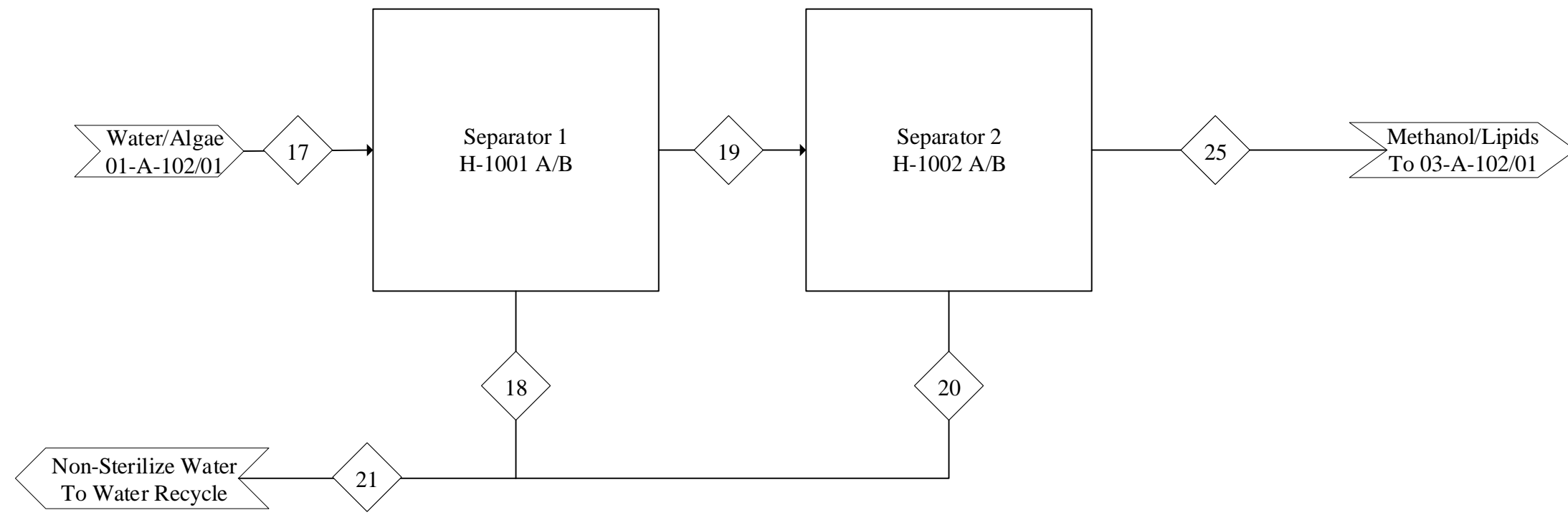

Mass Flow Rates in kg/hr

Stream	1	2	3	4	5	6	7	8	10	11	12	13	14	15	16	60	67	74
Water	1200	91	18	23000	1500	220	2	240	0	0	1800	21000	1100	0	55000	0	0	0
Biomass	0	0	0	0	0	0	0.014	0.2	0	0	14	0	0	0	370	0	0	0
Lipids	0	0	0	0	0	0	0.0024	0.036	0	0	2.4	0	0	0	66	0	0	0
BBM	1900	140	27	91	6.8	1.4	0	1.4	0	0	6.8	86	1700	0	185	0	0	0
O2	0	0	0	0	0	0	0	0	0	0	0	0	0	0	0	0.91	4.5	54
CO2	0	0	0	0	0	0	0	0	0.95	5.9	0	0	0	59	0	0.05	0.25	2.9
Total	3100	230	45	23000	1500	220	2	240	0.95	5.9	1800	21000	2800	59	56000	0.96	4.8	57



- Notes**
1. Drawings not to scale.
  2. Mass balance may not sum to total due to rounding
  3. In H-1001 A/B, the majority of the water is removed
  4. In H-1002 A/B, 95% of the residual water is removed
  5. The water in streams 18 and 20 are recycled

**Special Symbols / Nomenclature**

 Input/Output  
 Stream Number

**Reference Drawings:**

- 00-A-101
- 01-A-102
- 02-A-102
- 03-A-102
- 01-A-103
- 02-A-103
- 03-A-103

**Drawing Type**

Block Flow Diagram

**Title**

Drawing I3: Autotrophic Microalgae Oil Extraction

By/Date	DWG #/Sheet #	Rev	Page
JLK 1/22/19	02-A-102/01	0	I-3

Mass Flow Rates in kg/hr						
Stream	17	18	19	20	21	25
Water	45000	45000	19	18	45000	68
Biomass	320	0	320	0	0	320
Lipids	59	0	59	0	0	59
BBM	150	150	0.3	0.064	150	0.24
Total	46000	45000	400	18	45000	450

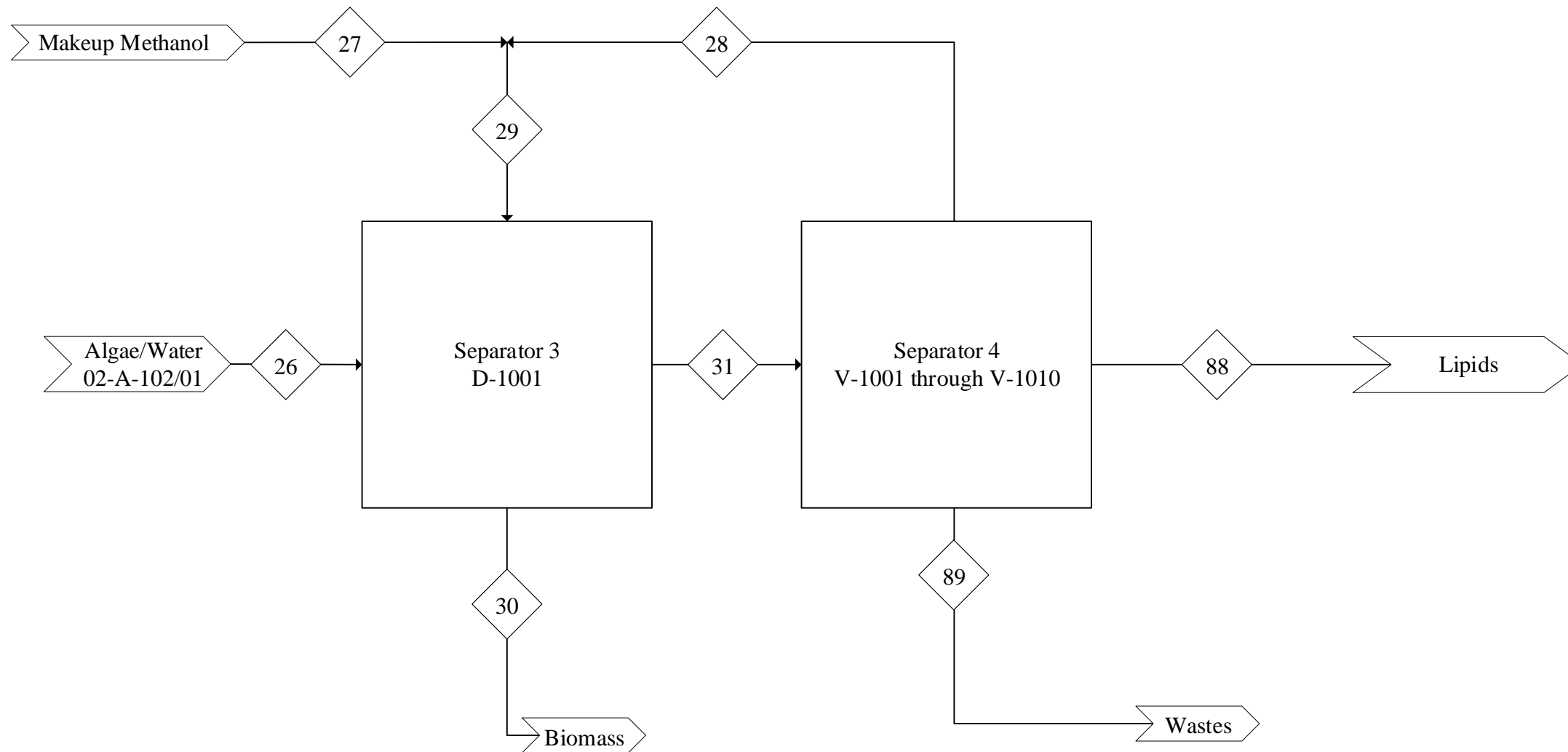

- Notes**
1. Drawings not to scale.
  2. Mass balance may not sum to total due to rounding
  3. In D-1001, the lipids are extracted from the biomass
  4. In V-1001 through V-1010, the methanol is separated from the lipids
  5. The methanol is recycled

**Special Symbols / Nomenclature**

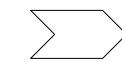
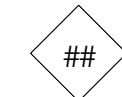
-  Input/Output
-  Stream Number

**Reference Drawings:**

- 00-A-101
- 01-A-102
- 02-A-102
- 03-A-102
- 01-A-103
- 02-A-103
- 03-A-103

**Drawing Type**

Block Flow Diagram

**Title**

Drawing I4: Autotrophic Microalgae Oil Extraction

Mass Flow Rates in kg/hr								
Stream	26	27	28	29	30	31	88	89
Water	68	0	0	0	0.31	68	Trace	Trace
Biomass	320	0	0	0	320	0	0	Trace
Lipids	59	0	0	0	0.27	59	59	32
BBM	0.24	0	Trace	Trace	0.0011	0.24	Trace	0.24
Methanol	0	150	2900	3000	13	3000	Trace	68
<b>Total</b>	<b>450</b>	<b>150</b>	<b>2900</b>	<b>3000</b>	<b>330</b>	<b>3100</b>	<b>59</b>	<b>100</b>

R-1001 A-C    L-1001 A/B    R-1002-1045    L-1002-1004 A/B  
 Microalgae Growth    R-1002: R-1045    Microalgae    R-1046: R-1689  
 Photo Bioreactor 1    Feed Pump    Growth Photo    Feed Pump  
 Diameter: 0.40 m    Power: 0.25 hp    Bioreactor 2    Power: 0.25 hp  
 Length: 3.4 m       Diameter: 0.40 m  
 Length: 16 m

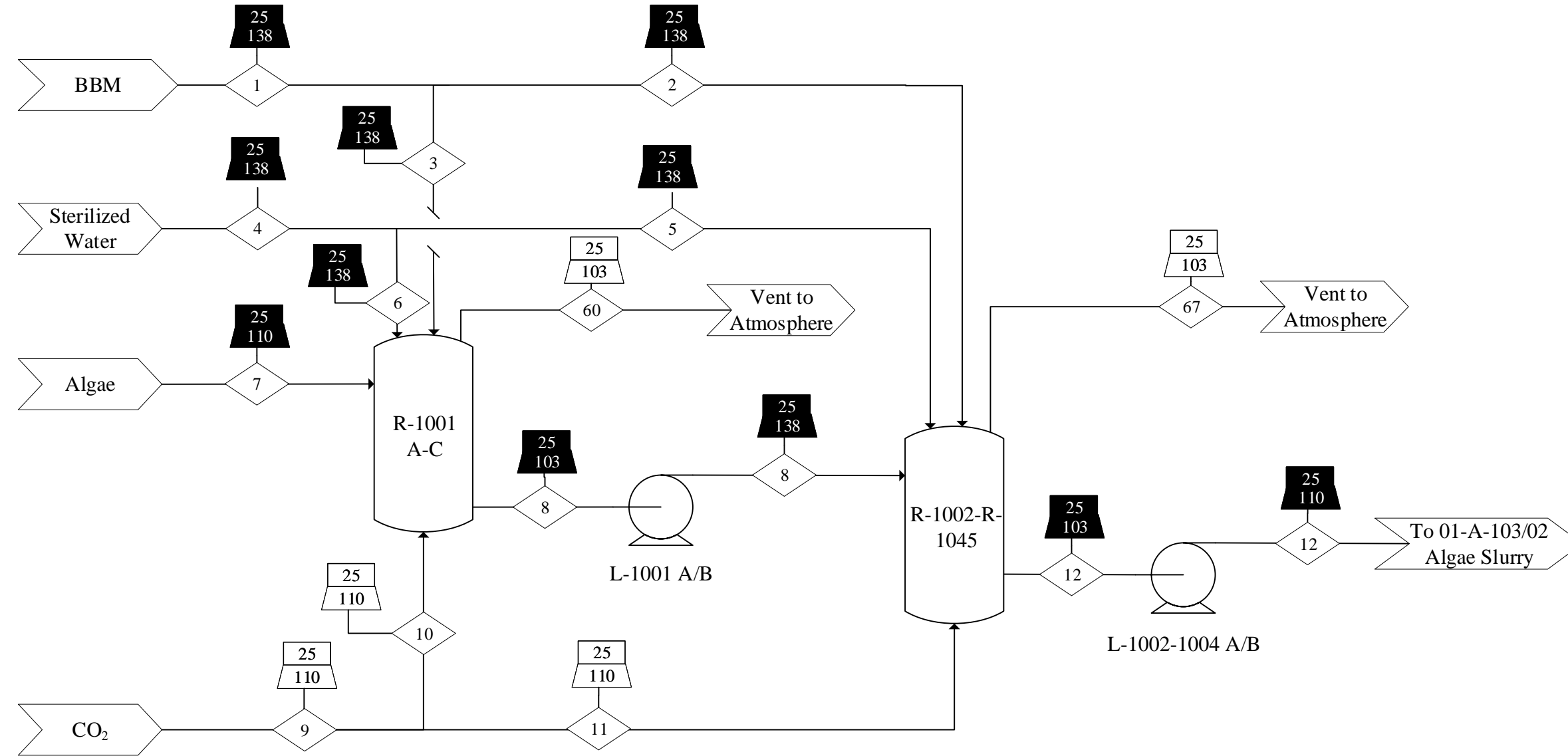

- Notes**
1. Drawing not to scale.
  2. Mass balance may not sum to total due to rounding.
  3. Not all Mass flow rates are continuous.

- Special Symbols / Nomenclature**
- ◇ # Stream Number
  - ## Temp (°C), liquid/solid
  - ### Pressure (kPa), liquid/solid
  - ## Temp (°C), gas
  - ### Pressure (kPa), gas
  - Input/Output
  - BBM Bolds Basal Media

- Reference Drawings:**
- 00-A-101
  - 01-A-102
  - 02-A-102
  - 03-A-102
  - 01-A-103
  - 02-A-103
  - 03-A-103

Mass Flow Rates in kg/hr														
Stream	1	2	3	4	5	6	7	8	9	10	11	12	60	67
Water	110	91	18	1700	1500	220	2	110	0	0	0	770	0	0
Biomass	0	0	0	0	0	0	0.014	0.2	0	0	0	14	0	0
Lipids	0	0	0	0	0	0	0.0024	0.036	0	0	0	2.4	0	0
BBM	160	140	27	0	0	0	0	1.4	0	0	0	6.8	0	0
Oxygen	0	0	0	0	0	0	0	0	0	0	0	0	0.91	4.5
CO2	0	0	0	0	0	0	0	0	5.9	0.95	5	0	0.05	0.25
Total	270	230	45	1700	1500	220	2.0	110	5.9	0.95	5	790	0.96	4.8

**Drawing Type**  
Process Flow Diagram

**Title**  
Drawing I5: Autotrophic Microalgae Oil Extraction

R-1042-1685 Microalgae Growth Photo Bioreactor 3 Diameter: 0.40 m Length: 190 m	L-1005-1050 A/B Holding Tank Feed Pump Power: 0.25 hp	T-1001 A-C Microalgae Holding Tank Height: 7.0 m Diameter: 11 m	L-1051 A/B Rotary Drum Filter Feed Pump Power: 0.25 hp
---	--	---	---

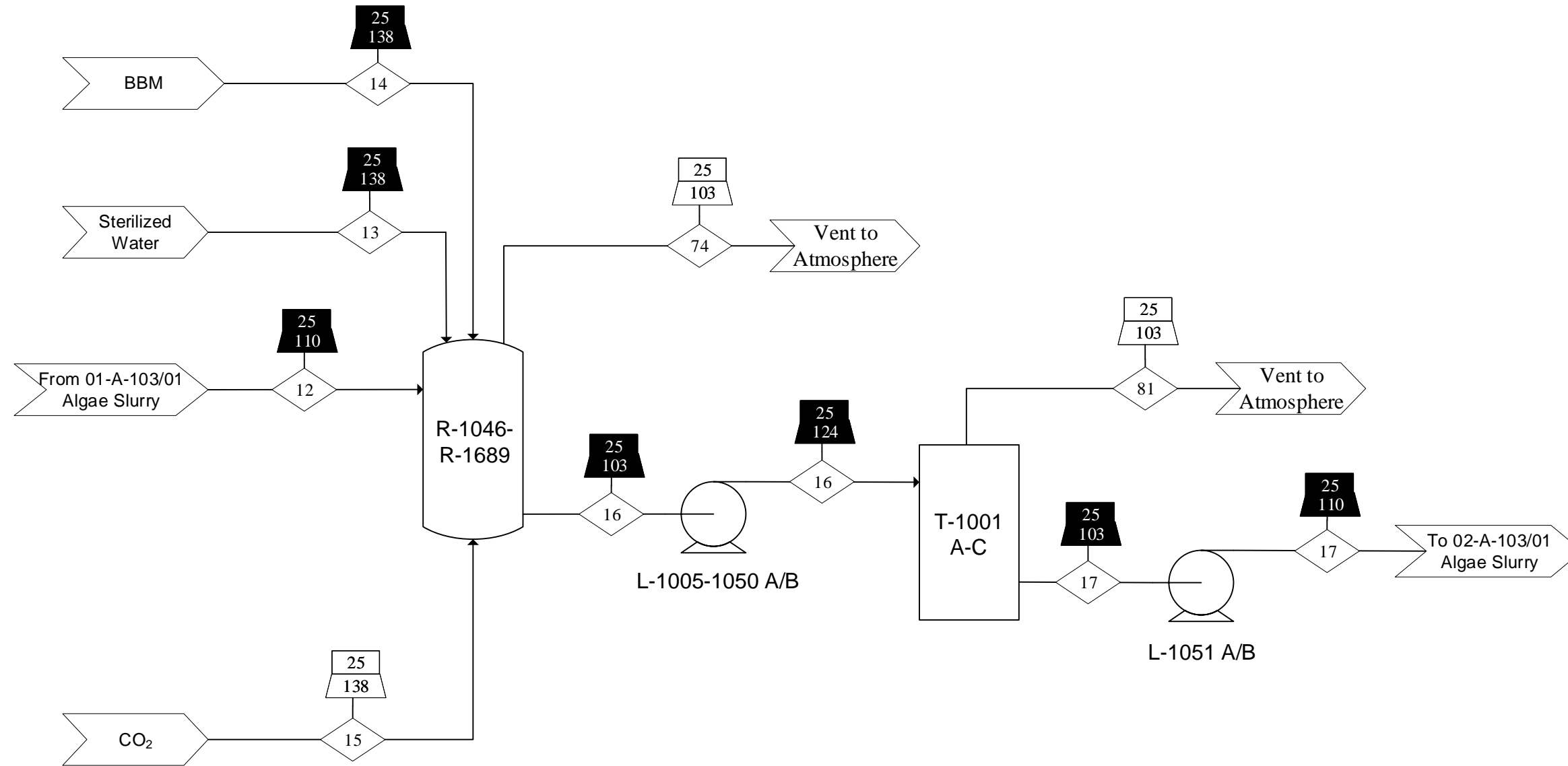

- Notes**
1. Drawing not to scale.
  2. Mass balance may not sum to total due to rounding.
  3. Mass flow rates are not continuous.

**Special Symbols / Nomenclature**

- ◇ # Stream Number
- ## Temp (°C), liquid/solid
- ### Pressure (kPa), liquid/solid
- ## Temp (°C), gas
- ### Pressure (kPa), gas
- Input/Output
- BBM Bolds Basal Media

**Reference Drawings:**

- 00-A-101
- 01-A-102
- 02-A-102
- 03-A-102
- 01-A-103
- 02-A-103
- 03-A-103

**Drawing Type**  
Process Flow Diagram

**Title**  
Drawing I6: Autotrophic  
Microalgae Oil Extraction

Mass Flow Rates in kg/hr								
Stream	12	13	14	15	16	17	74	81
Water	1800	21000	1100	0	25000	45000	0	0
Biomass	14	0	0	0	170	320	0	0
Lipids	2.4	0	0	0	30	59	0	0
BBM	6.8	0	1700	0	84	200	0	0
Oxygen	0	0	0	0	0	0	54	140
Nitrogen	0	0	0	0	0	0	0	590
CO2	0	0	0	59	0	0	2.9	0
Total	1800	21000	2800	59	25000	46000	57	730

H-1001 A/B Rotary Drum Filter Power: 0.50 hp Area: 3.5 m <sup>2</sup>	J-1001 A/B Dried Microalgae Transfer Conveyor Length: 15 m Width: 0.61 m Power: 1.0 hp	L-1052 A/B Rotary Drum Filter Water Recycle Pump Power: 2.0 hp	H-1002 A/B Belt Press Power: 0.50 hp Area: 3.3 m <sup>2</sup>	L-1054 A/B Belt Press Water Recycle Pump Power: 0.25 hp	J-1002 A/B Pressed Microalgae Transfer Conveyor Length: 15 m Width: 0.61 m Power: 1.0 hp	C-1001 Fine Grinder Capacity: 380 kg/hr Power: 30 hp	J-1003 A/B Ground Microalgae Transfer Conveyor Length: 15 m Width: 0.61 m Power: 1.0 hp	E-1001 A/B Process Water Recycle Sterilizer Area: 520 m <sup>2</sup> Duty: 19 MJ/hr	L-1053 A/B Process Water Recycle Pump Power: 3.5 hp
---	---	--	--	--	---	---	--	---	--

**Notes**

- Drawing not to scale.
- Mass flow rates are in lb/hour.
- Mass balance may not sum to total due to rounding.

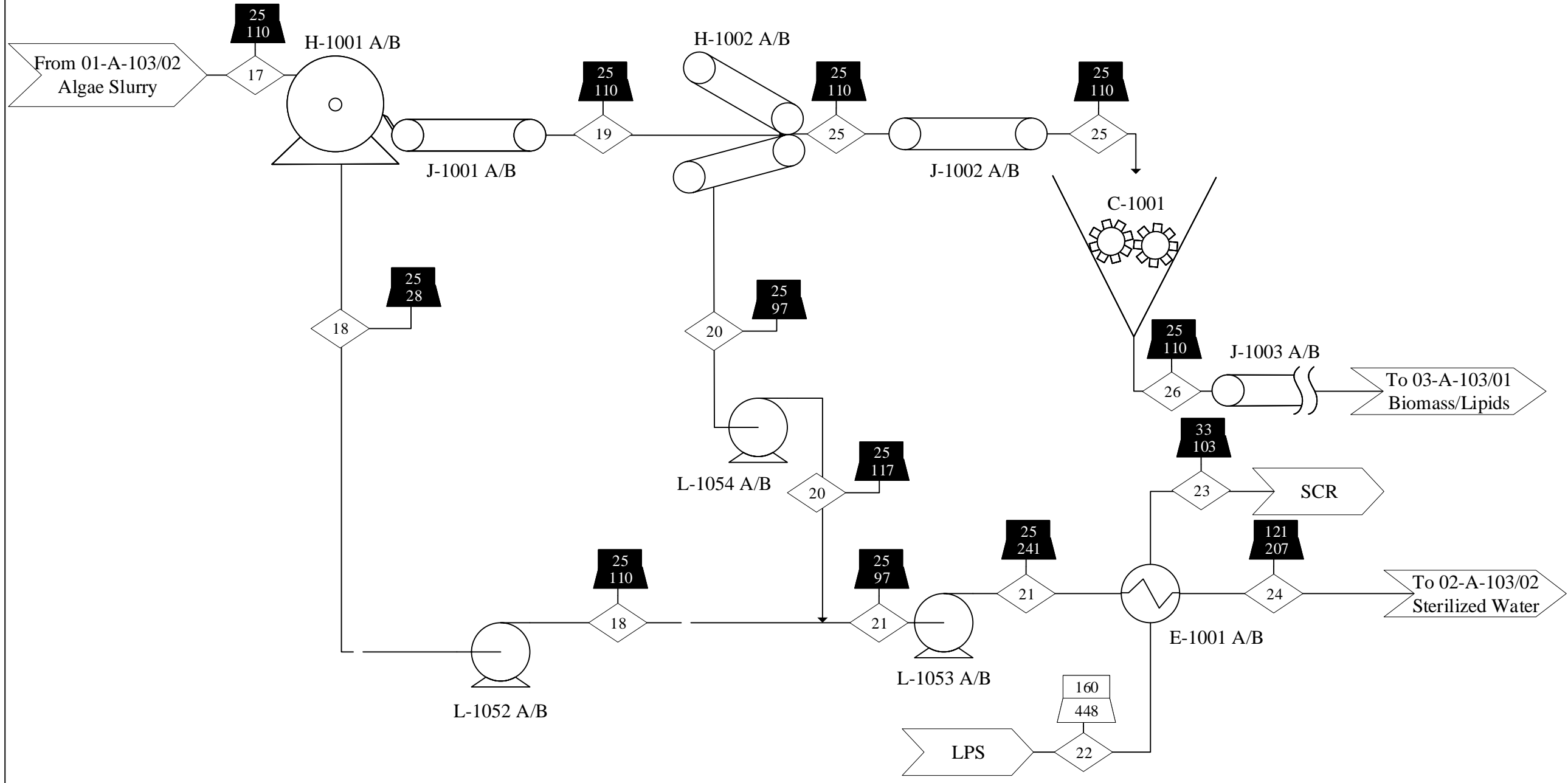

**Special Symbols / Nomenclature**

- ◇ # Stream Number
- ▤ ## Temp (°C), liquid/solid
- ▤ ### Pressure (kPa), liquid/solid
- ▤ ## Temp (°C), gas
- ▤ ### Pressure (kPa), gas
- ▤ Input/Output
- ▤ LPS Low Pressure Steam
- ▤ SCR Steam Condensate Return

**Reference Drawings:**

- 00-A-101
- 01-A-102
- 02-A-102
- 03-A-102
- 01-A-103
- 02-A-103
- 03-A-103

**Drawing Type**  
Process Flow Diagram

**Title**  
Drawing I7: Autotrophic Microalgae Oil Extraction

Mass Flow Rate kg/hr										
Stream	17	18	19	20	21	22	23	24	25	26
Water	45000	45000	86	18	45000	7300	7300	45000	68	68
Biomass	320	0	320	0	0	0	0	0	320	320
Lipids	59	0	59	0	0	0	0	0	59	59
BBM	150	150	0.3	0.064	150	0	0	150	0.24	0.24
Total	46000	45000	470	18	45000	7300	7300	45000	450	450



T-1002  
Process Water  
Recycle Holding Tank  
Height: 9.4 m  
Diameter: 14 m

E-1006 A/B  
Process Water Recycle  
Cooler  
Area: 520 m<sup>2</sup>  
Duty: 19 MJ/hr

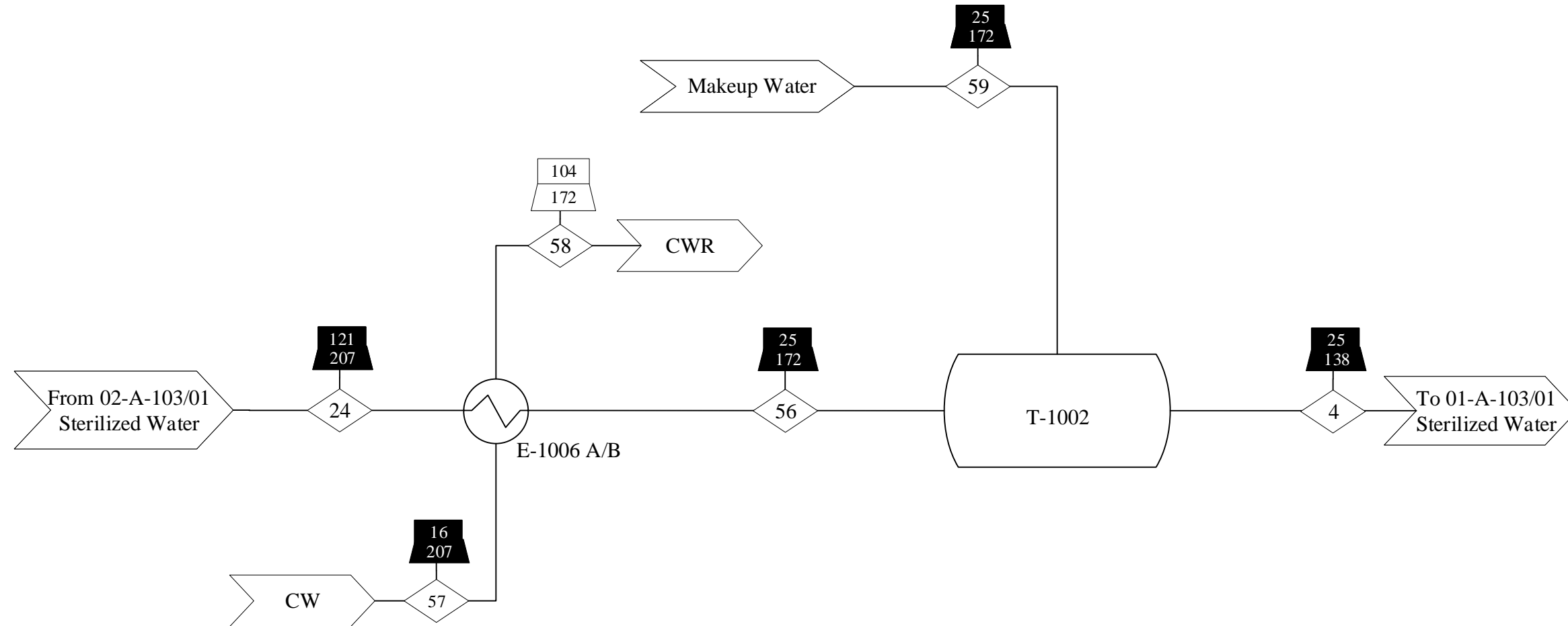

- Notes**
1. Drawing not to scale.
  2. Mass balance may not sum to total due to rounding.
  3. Not all mass flow rates are continuous.

- Special Symbols / Nomenclature**
- # Stream Number
  - ## Temp (°C), liquid/solid
  - ### Pressure (kPa), liquid/solid
  - ## Temp (°C), gas
  - ### Pressure (kPa), gas
  - Input/Output
  - BBM Bolds Basal Media

- Reference Drawings:**
- 00-A-101
  - 01-A-102
  - 02-A-102
  - 03-A-102
  - 01-A-103
  - 02-A-103
  - 03-A-103

**Drawing Type**  
Process Flow Diagram

**Title**  
Drawing I8: Autotrophic  
Microalgae Oil Extraction

Mass Flow Rates in kg/hr						
Stream	4	24	56	57	58	59
Water	21000	45000	45000	6800	6800	2300
Biomass	0	0	0	0	0	0
Lipids	0	0	0	0	0	0
BBM	77	200	200	0	0	0
Oxygen	0	0	0	0	0	0
CO2	0	0	0	0	0	0
Total	21000	45000	45000	6800	6800	2300

By/Date	DWG #/Sheet #	Rev	Page
JLK 1/22/19	02-A-103/02	0	I-8

J-1003 A/B Ground Microalgae Transfer Conveyor Length: 15 m Width: 0.61 m Power: 1.0 hp	J-1004 A/B Ground Microalgae Transfer Screw Feeder Length: 4.6 m Diameter: 0.10 Power: 0.25 hp	D-1001 Leacher Height: 2.5 m Diameter: 3.7 m Mixing Power: 36 hp	D-1002 Methanol Surge Drum Height: 2.4 m Diameter: 0.82 m	J-1005 A/B Biomass Product Transfer Extruder Length: 15 m Width: 0.61 m Power: 0.25 hp	J-1006 A/B Biomass Product Transfer Conveyor Length: 15 m Width: 0.61 m Power: 1.0 hp
--	---	--	---	---	--

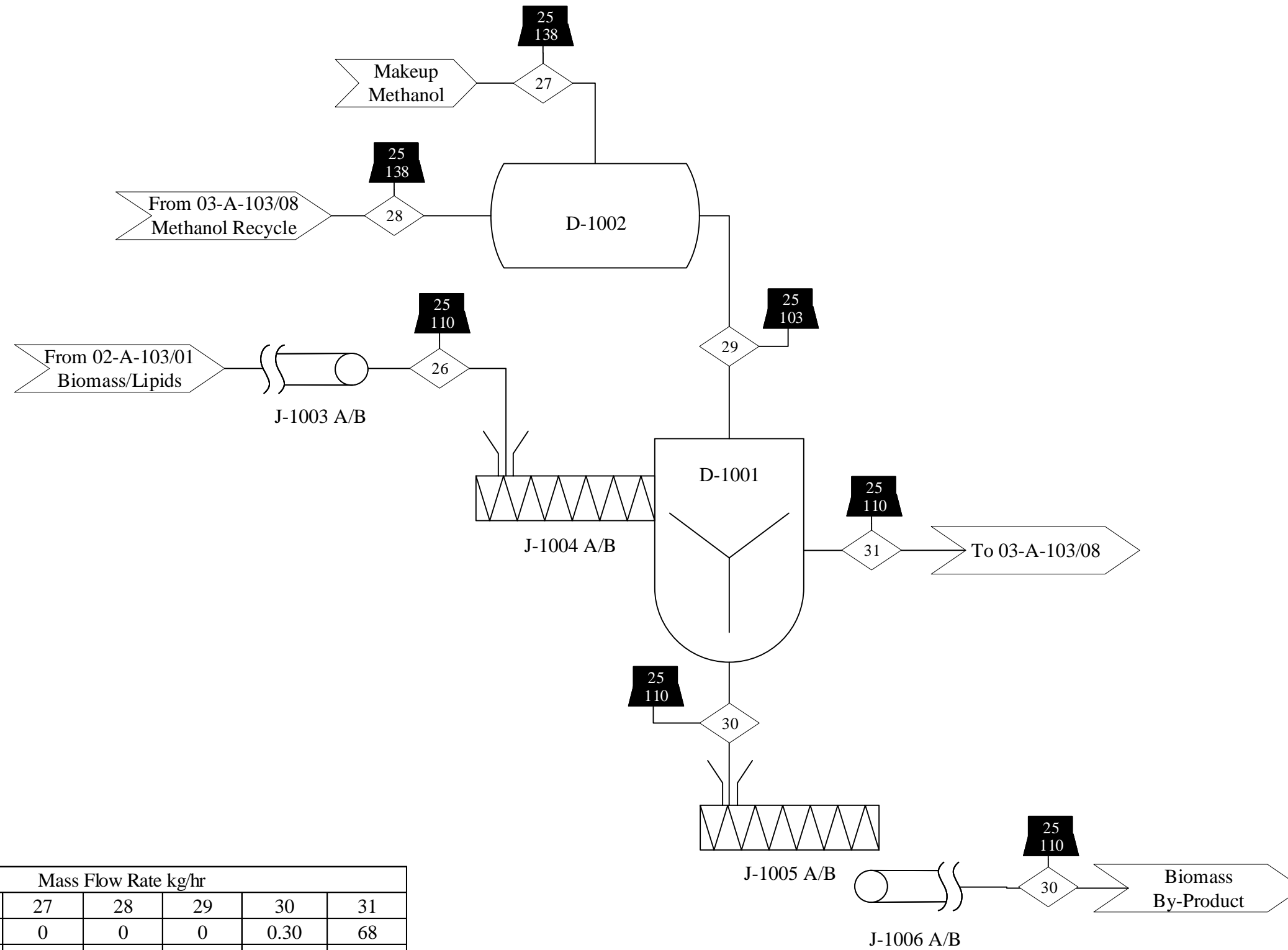

	Mass Flow Rate kg/hr					
Stream	26	27	28	29	30	31
Water	68	0	0	0	0.30	68
Biomass	320	0	0	0	320	0
Lipids	59	0	0	0	0.27	59
BBM	0.24	0	Trace	Trace	0.0011	0.24
Methanol	0	150	2900	3000	13	3000
Total	450	150	2900	3000	330	3100

**Notes**

1. Drawing not to scale.
2. Mass flow rates are in lb/hour.
3. Mass balance may not sum to total due to rounding.

**Special Symbols / Nomenclature**

- # Stream Number
- ## Temp (°C), liquid/solid
- ### Pressure (kPa), liquid/solid
- Input/Output

**Reference Drawings:**

- 00-A-101
- 01-A-102
- 02-A-102
- 03-A-102
- 01-A-103
- 02-A-103
- 03-A-103

**Drawing Type**

Process Flow Diagram

**Title**

Drawing I9: Autotrophic Microalgae Oil Extraction

By/Date JLK 1/22/19	DWG #/Sheet # 03-A-103/01	Rev 0	Page I-9
---------------------------	------------------------------	----------	-------------

**V-1001**  
Multi-Effect Evaporator  
Effect 1  
Area: 10 m<sup>2</sup>  
Duty: 1.9 MJ/hr  
Height: 2.5 m  
Top Diameter: 1.0 m  
Bottom Diameter: 0.52 m

**V-1002**  
Multi-Effect Evaporator  
Effect 2  
Area: 10 m<sup>2</sup>  
Duty: 1.2 MJ/hr  
Height: 2.5 m  
Top Diameter: 1.0 m  
Bottom Diameter: 0.52 m

**E-1002 A/B**  
Methanol Recycle  
Sub-Cooler  
Area: 1.6 m<sup>2</sup>  
Duty: 0.0056 MJ/hr

**L-1055 A/B**  
V-1001 Bottoms  
Stream Pump  
Power: 0.25 hp

**L-1056 A/B**  
V-1002 Bottoms  
Stream Pump  
Power: 0.25 hp

**Notes**

1. Drawing not to scale.
2. Mass flow rates are in lb/hour.
3. Mass balance may not sum to total due to rounding.

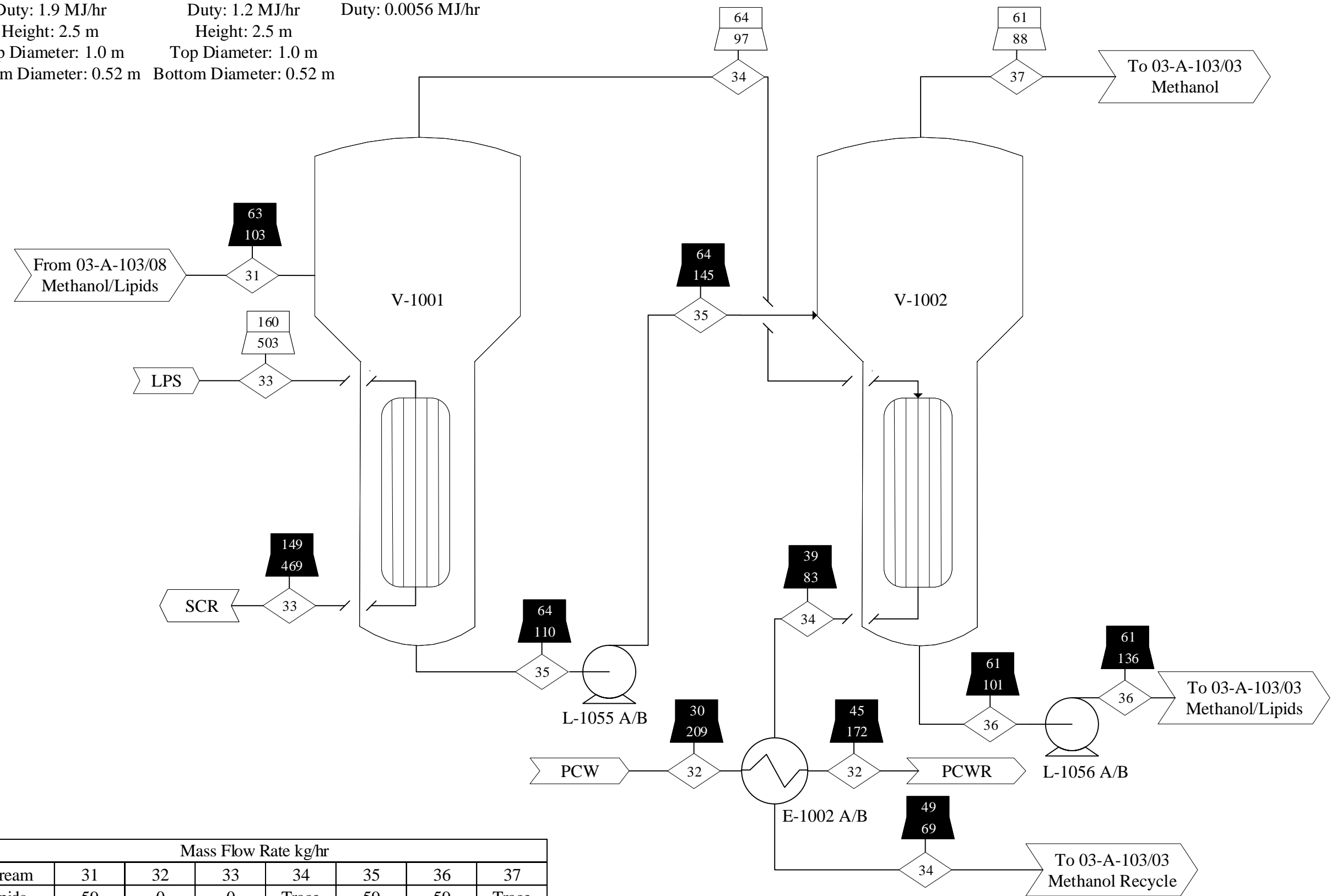

**Special Symbols / Nomenclature**

- ◇ # Stream Number
- ## Temp (°C), gas
- ### Pressure (kPa), gas
- ## Temp (°C), liquid/solid
- ### Pressure (kPa), liquid/solid
- ▭ Input/Output
- ▭ PCW Process Cooling Water
- ▭ PCWR Process Cooling Water Return
- ▭ LPS Low Pressure Steam
- ▭ SCR Steam Condensate Return

**Reference Drawings:**

- 00-A-101
- 01-A-102
- 02-A-102
- 03-A-102
- 01-A-103
- 02-A-103
- 03-A-103

**Drawing Type**  
Process Flow Diagram

**Title**  
Drawing I10: Autotrophic Microalgae Oil Extraction

Mass Flow Rate kg/hr							
Stream	31	32	33	34	35	36	37
Lipids	59	0	0	Trace	59	59	Trace
Methanol	3000	0	0	310	2700	2400	310
BBM	0.24	0	0	Trace	0.24	0.24	Trace
Water	68	100	160	Trace	68	68	Trace
Total	3100	100	160	310	2800	2500	310

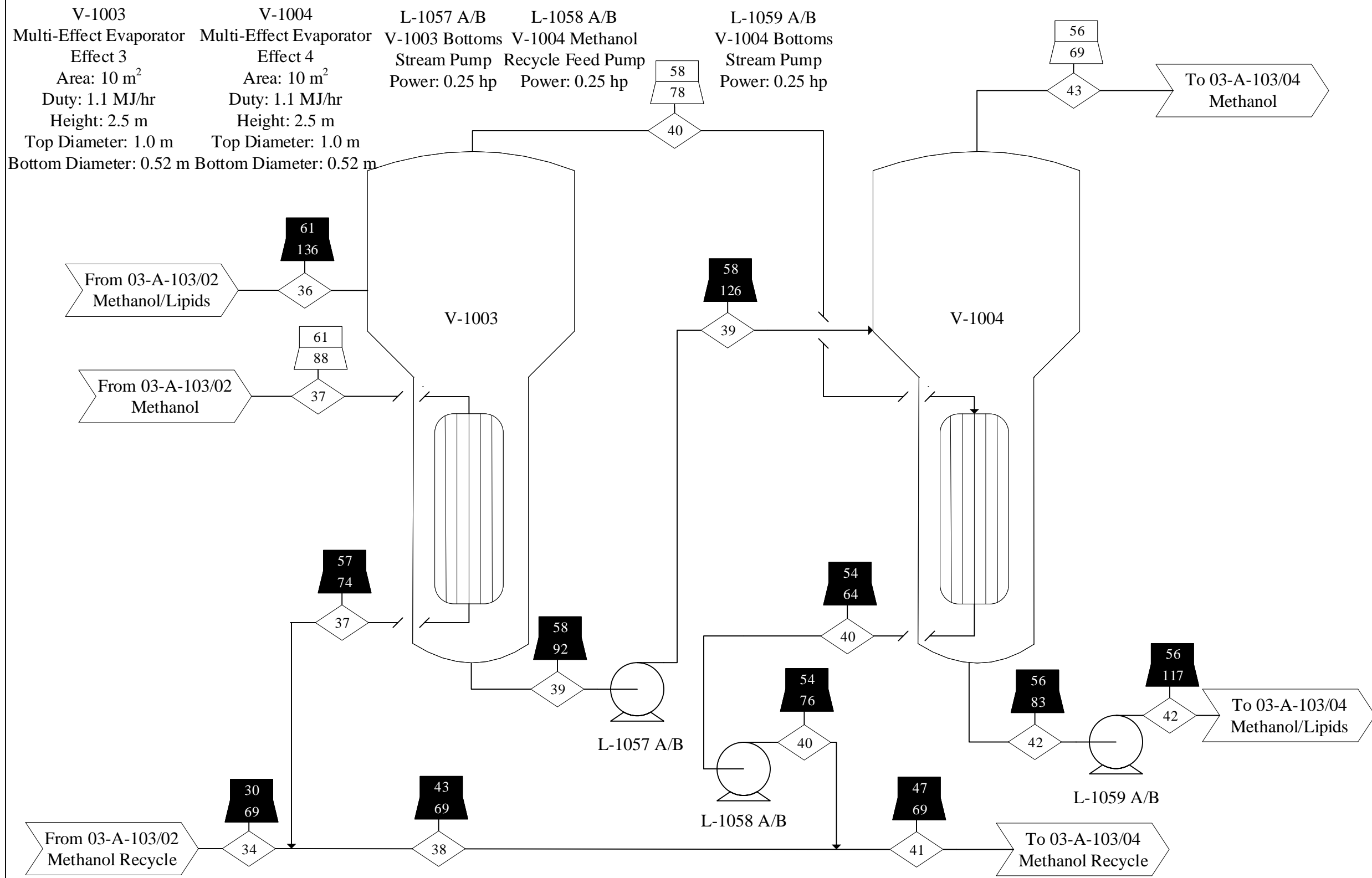

**Notes**

1. Drawing not to scale.
2. Mass flow rates are in lb/hour.
3. Mass balance may not sum to total due to rounding.

**Special Symbols / Nomenclature**

- ◇ # Stream Number
- ▤ ## Temp (°C), gas
- ▥ ### Pressure (kPa), gas
- ▧ ## Temp (°C), liquid/solid
- ▨ ### Pressure (kPa), liquid/solid
- ▩ Input/Output

**Reference Drawings:**

- 00-A-101
- 01-A-102
- 02-A-102
- 03-A-102
- 01-A-103
- 02-A-103
- 03-A-103

**Drawing Type**  
Process Flow Diagram

**Title**  
Drawing I11: Autotrophic Microalgae Oil Extraction

By/Date JLK 1/22/19	DWG #/ Sheet # 03-A-103/03	Rev 0	Page I-11
---------------------------	-------------------------------	----------	--------------

Mass Flow Rate kg/hr									
Stream	34	36	37	38	39	40	41	42	43
Lipids	Trace	59	Trace	Trace	59	Trace	Trace	59	Trace
Methanol	310	2400	310	640	2100	300	910	1800	300
BBM	Trace	0.24	Trace	Trace	0.24	Trace	Trace	0.24	Trace
Water	Trace	68	Trace	Trace	68	Trace	Trace	68	Trace
<b>Total</b>	<b>310</b>	<b>2500</b>	<b>310</b>	<b>640</b>	<b>2200</b>	<b>300</b>	<b>910</b>	<b>1900</b>	<b>300</b>

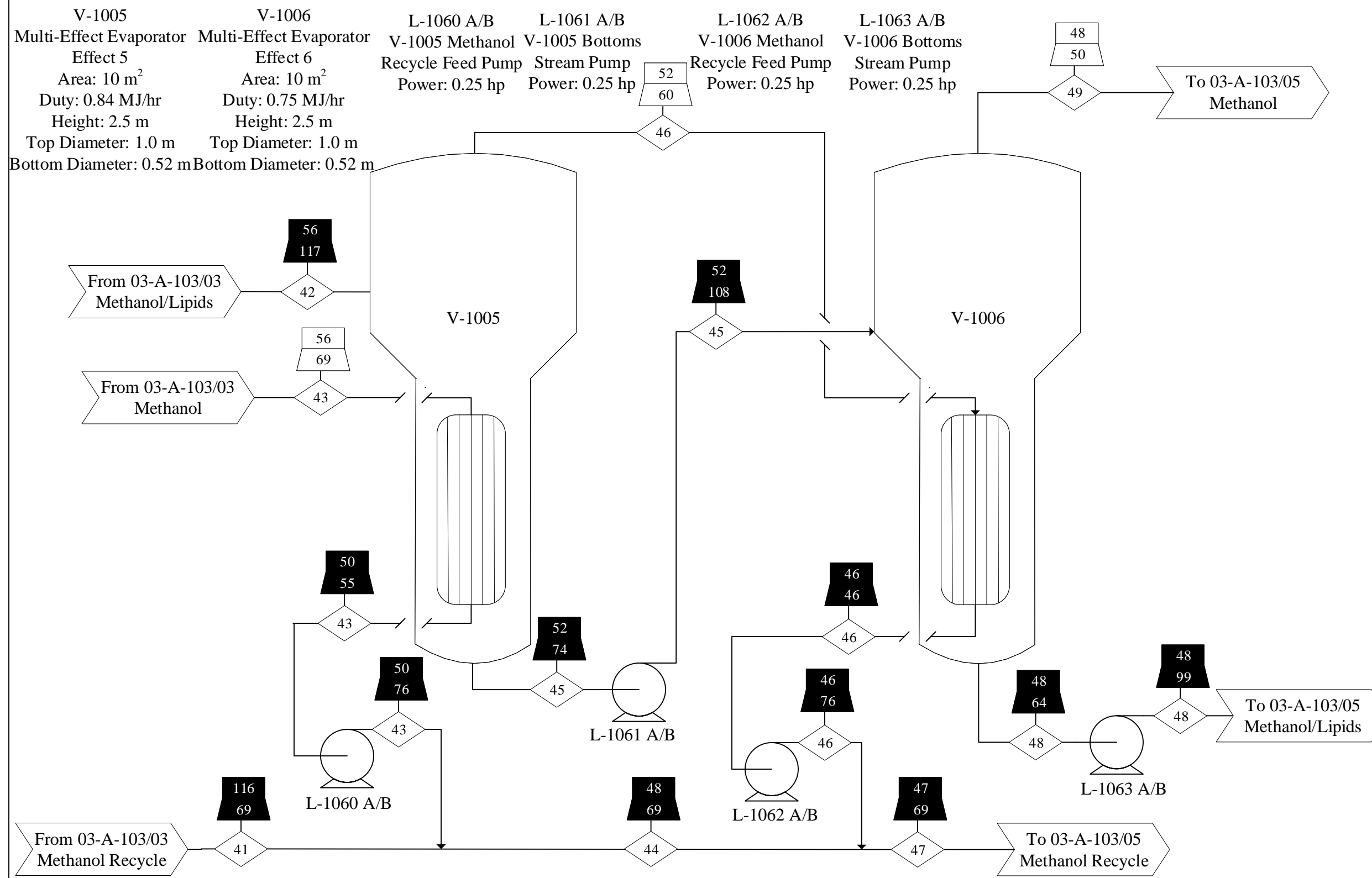

Mass Flow Rate kg/hr									
Stream	41	42	43	44	45	46	47	48	49
Lipids	Trace	59	Trace	Trace	59	Trace	Trace	59	Trace
Methanol	910	1800	300	1200	1500	300	1500	1200	290
BBM	Trace	0.24	Trace	Trace	0.24	Trace	Trace	0.24	Trace
Water	Trace	68	Trace	Trace	68	Trace	Trace	68	Trace
Total	910	1900	300	1200	1600	300	1500	1300	290

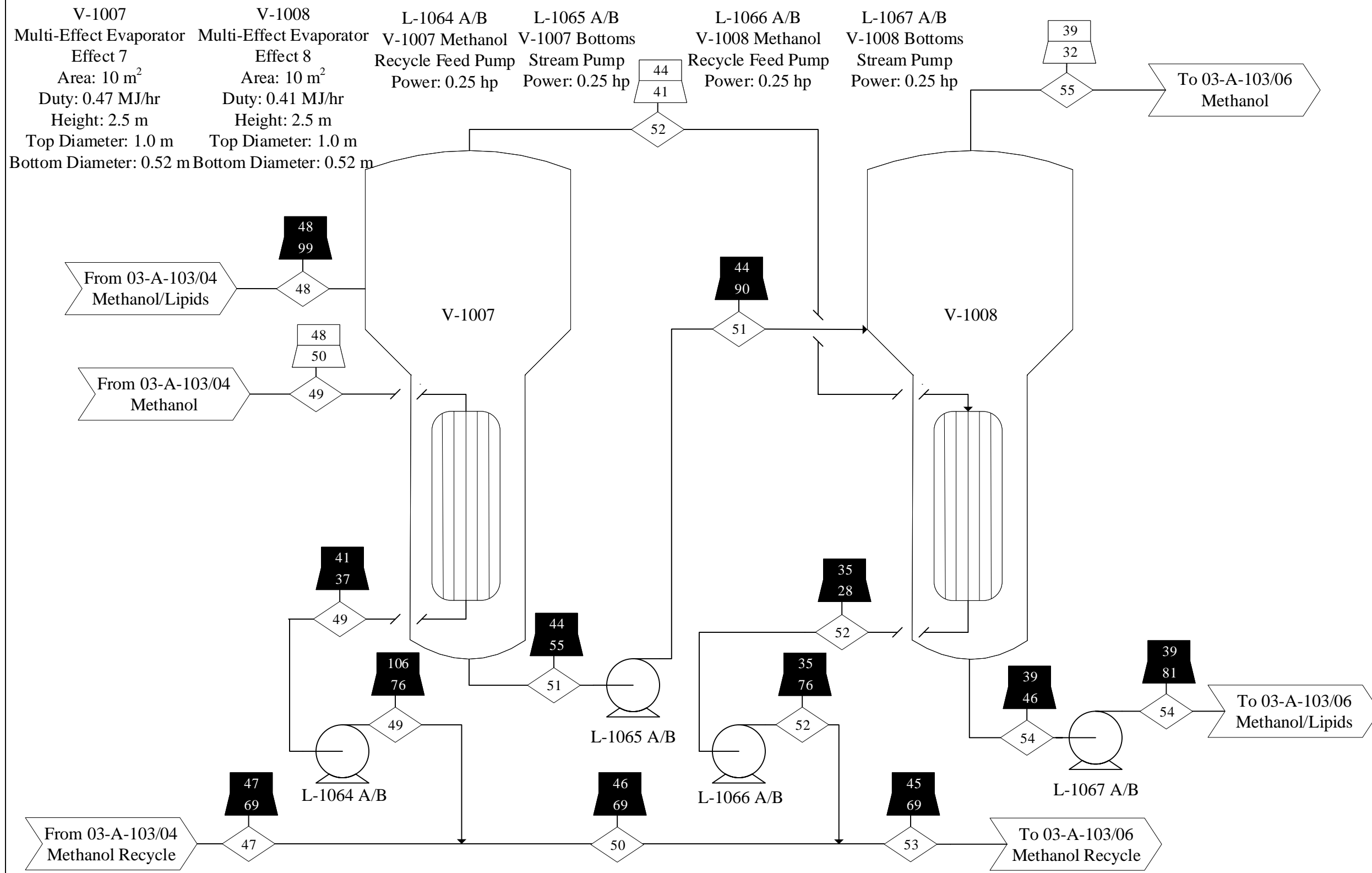

**Notes**

1. Drawing not to scale.
2. Mass flow rates are in lb/hour.
3. Mass balance may not sum to total due to rounding.

**Special Symbols / Nomenclature**

- ◇ # Stream Number
- ## Temp (°C), gas
- ### Pressure (kPa), gas
- ## Temp (°C), liquid/solid
- ### Pressure (kPa), liquid/solid
- ⬠ Input/Output

**Reference Drawings:**

- 00-A-101
- 01-A-102
- 02-A-102
- 03-A-102
- 01-A-103
- 02-A-103
- 03-A-103

**Drawing Type**

Process Flow Diagram

**Title**

Drawing I13: Autotrophic Microalgae Oil Extraction

By/Date	DWG #/ Sheet #	Rev	Page
JLK 1/22/19	03-A-103/05	0	I-13

Mass Flow Rate kg/hr									
Stream	47	48	49	50	51	52	53	54	55
Lipids	Trace	59	Trace	Trace	59	Trace	Trace	59	Trace
Methanol	1500	1200	290	1800	910	290	2100	590	290
BBM	Trace	0.24	Trace	Trace	0.24	Trace	Trace	0.24	Trace
Water	Trace	68	Trace	Trace	68	Trace	Trace	68	Trace
<b>Total</b>	<b>1500</b>	<b>1300</b>	<b>290</b>	<b>1800</b>	<b>1000</b>	<b>290</b>	<b>2100</b>	<b>720</b>	<b>290</b>

V-1009  
Multi-Effect Evaporator  
Effect 9  
Area: 10 m<sup>2</sup>  
Duty: 0.21 MJ/hr  
Height: 2.5 m  
Top Diameter: 1.0 m  
Bottom Diameter: 0.52 m

L-1068 A/B  
V-1009 Methanol  
Recycle Feed Pump  
Power: 0.25 hp

L-1069 A/B  
V-1009 Bottoms  
Stream Pump  
Power: 0.25 hp

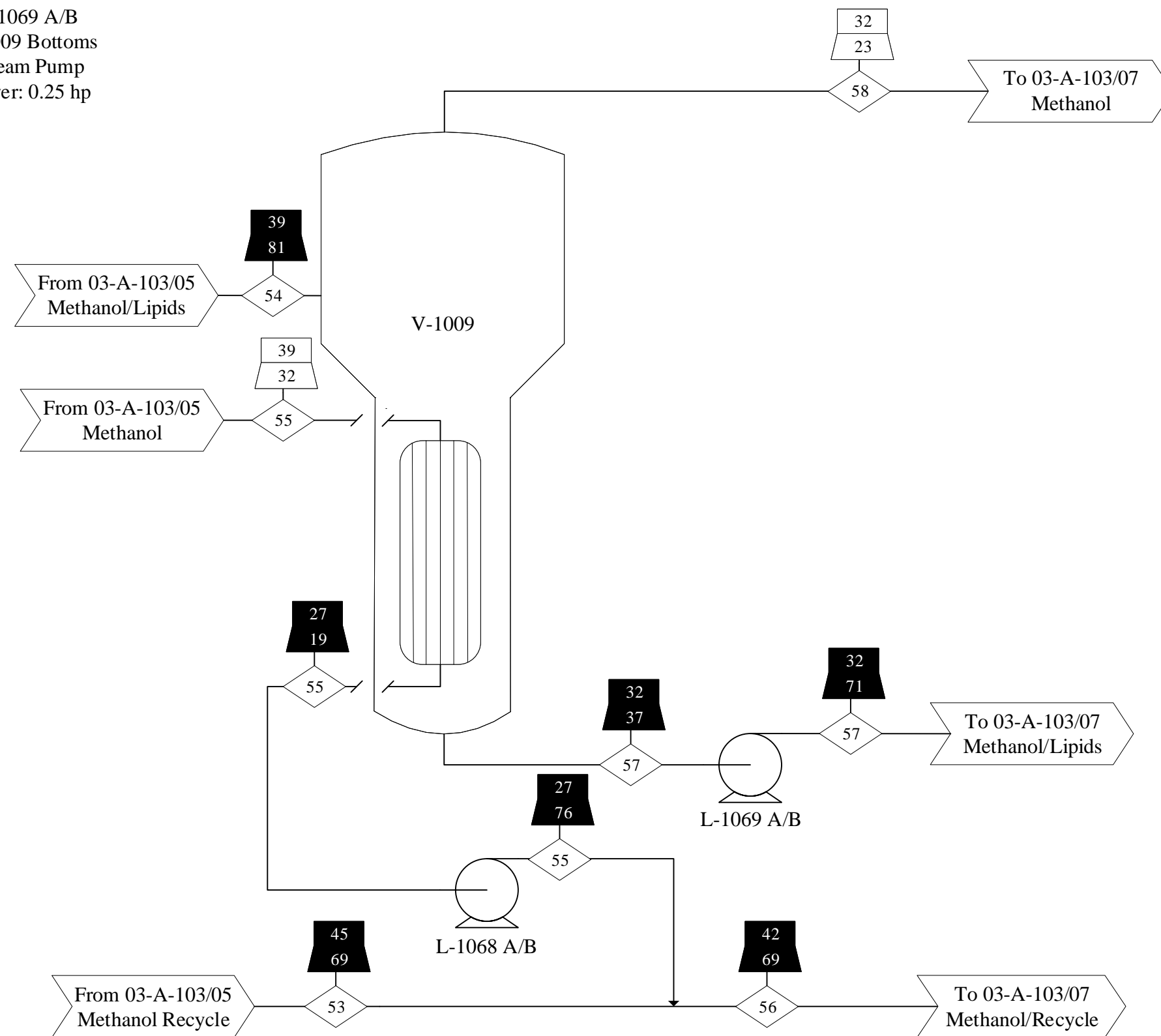

**Notes**

1. Drawing not to scale.
2. Mass flow rates are in lb/hour.
3. Mass balance may not sum to total due to rounding.

**Special Symbols / Nomenclature**

# Stream Number

## Temp (°C), gas  
### Pressure (kPa), gas

## Temp (°C), liquid/solid  
### Pressure (kPa), liquid/solid

Input/Output

**Reference Drawings:**

- 00-A-101
- 01-A-102
- 02-A-102
- 03-A-102
- 01-A-103
- 02-A-103
- 03-A-103

**Drawing Type**

Process Flow Diagram

**Title**

Drawing I14: Autotrophic Microalgae Oil Extraction

By/Date JLK 1/22/19	DWG #/ Sheet # 03-A-103/06	Rev 0	Page I-14
---------------------------	-------------------------------	----------	--------------

	Mass Flow Rate kg/hr					
Stream	53	54	55	56	57	58
Lipids	Trace	59	Trace	Trace	59	Trace
Methanol	2100	590	290	2400	310	280
BBM	Trace	0.24	Trace	Trace	0.24	Trace
Water	Trace	68	Trace	Trace	68	Trace
Total	2100	720	290	2400	440	280

V-1010  
Multi-Effect Evaporator  
Effect 7  
Area: 10 m<sup>2</sup>  
Duty: 0.056 MJ/hr  
Height: 2.5 m  
Top Diameter: 1.0 m  
Bottom Diameter: 0.52 m

L-1070 A/B  
V-1010 Methanol  
Recycle Feed Pump  
Power: 0.25 hp

L-1071 A/B  
Lipids Product Feed  
Pump  
Power: 0.25 hp

L-1072 A/B  
Methanol/Water  
Waste Treatment  
Feed Pump  
Power: 0.25 hp

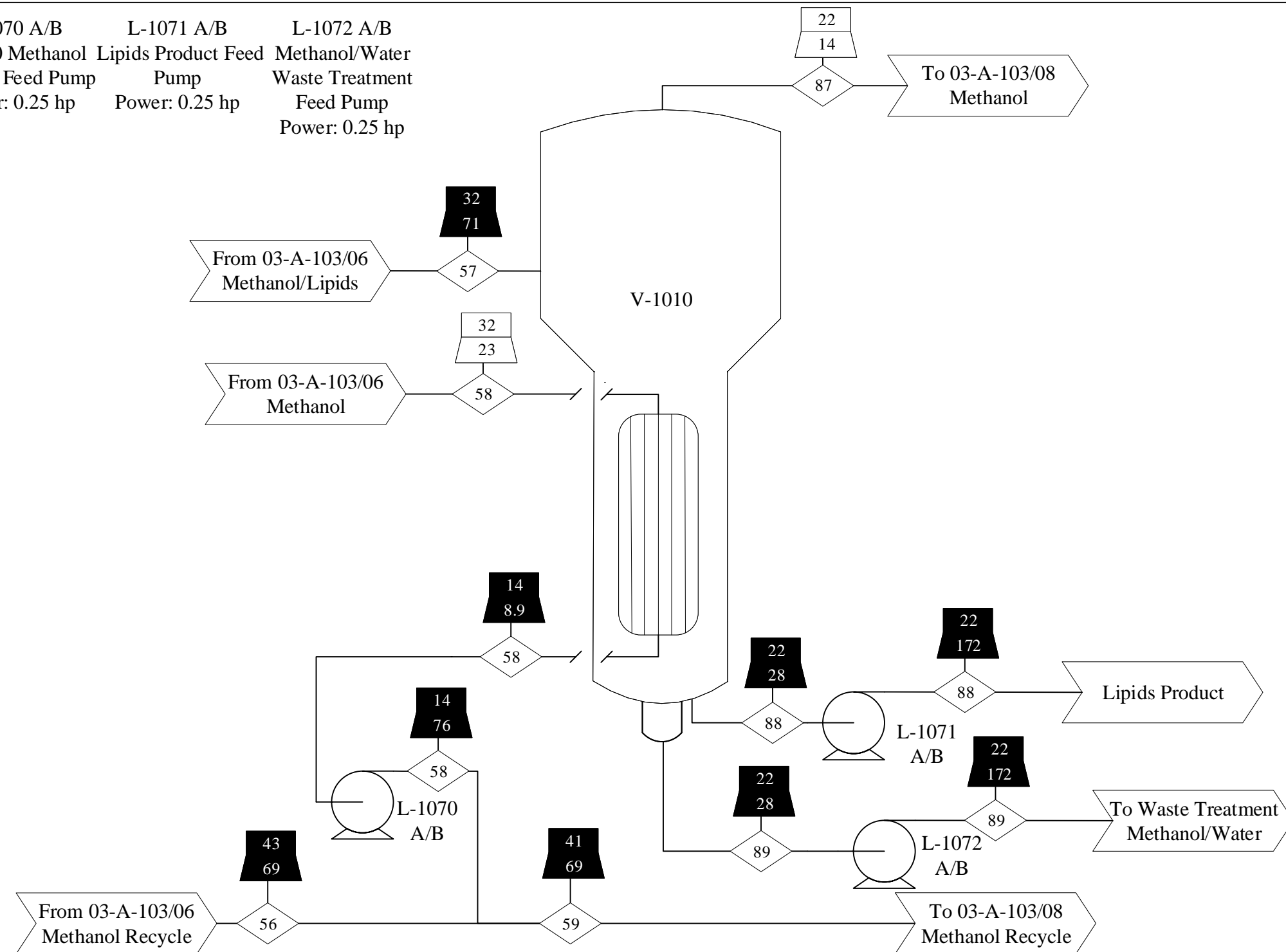

**Notes**

1. Drawing not to scale.
2. Mass flow rates are in lb/hour.
3. Mass balance may not sum to total due to rounding.

**Special Symbols / Nomenclature**

- # Stream Number
- ## Temp (°C), gas
- ### Pressure (kPa), gas
- ## Temp (°C), liquid/solid
- ### Pressure (kPa), liquid/solid
- ## Temp (°C), Mixed Phase
- ### Pressure (psi<sub>a</sub>), Mixed Phase
- Input/Output
- PCW Process Cooling Water
- PCWR Process Cooling Water Return

**Reference Drawings:**

- 00-A-101
- 01-A-102
- 02-A-102
- 03-A-102
- 01-A-103
- 02-A-103
- 03-A-103

**Drawing Type**  
Process Flow Diagram

**Title**  
Drawing I15: Autotrophic Microalgae Oil Extraction

Mass Flow Rate kg/hr							
Stream	56	57	58	59	87	88	89
Lipids	Trace	59	Trace	Trace	Trace	59	Trace
Methanol	2400	310	280	2700	280	Trace	32
BBM	Trace	0.24	Trace	Trace	Trace	Trace	0.24
Water	Trace	68	Trace	Trace	Trace	Trace	68
Total	2400	440	280	2700	280	59	100



E-1003 A/B V-1010 Methanol Recycle/ V-1001 Feed Cross- Exchanger Area: 7.2 m <sup>2</sup> Duty: 0.20 MJ/hr	E-1004 A/B V-1010 Methanol Recycle Condenser Area: 4.5 m <sup>2</sup> Duty: 0.074 MJ/hr	E-1005 A/B Surge Drum Methanol Pre-Cooler Area: 7.9 m <sup>2</sup> Duty: 0.083 MJ/hr	L-1073 A/B Lipid/Methanol Cross Exchanger Feed Pump Power: 0.25 hp	L-1074 A/B Total Methanol Recycle Pump Power: 0.25 hp	G-1001 V-1010 Methanol Recycle Compressor Stages: 1 Power: 40 hp
---	---	--	--	--	--

**Notes**

- Drawing not to scale.
- Mass flow rates are in lb/hour.
- Mass balance may not sum to total due to rounding.

**Special Symbols / Nomenclature**

- Stream Number
- Temp (°C), gas
- Pressure (kPa), gas
- Temp (°C), liquid/solid
- Pressure (kPa), liquid/solid
- Temp (°C), Mixed Phase
- Pressure (psi<sub>a</sub>), Mixed Phase
- Input/Output
- Process Cooling Water
- Process Cooling Water Return
- Moderately Low Temp Refrigerated Water
- Moderately Low Temp Refrigerated Water Return

- Reference Drawings:**
- 00-A-101
  - 01-A-102
  - 02-A-102
  - 03-A-102
  - 01-A-103
  - 02-A-103
  - 03-A-103

**Drawing Type**  
Process Flow Diagram

**Title**  
Drawing I16: Autotrophic Microalgae Oil Extraction

By/Date JLK 1/22/19	DWG #/ Sheet # 03-A-103/08	Rev 0	Page I-16
---------------------------	-------------------------------	----------	--------------

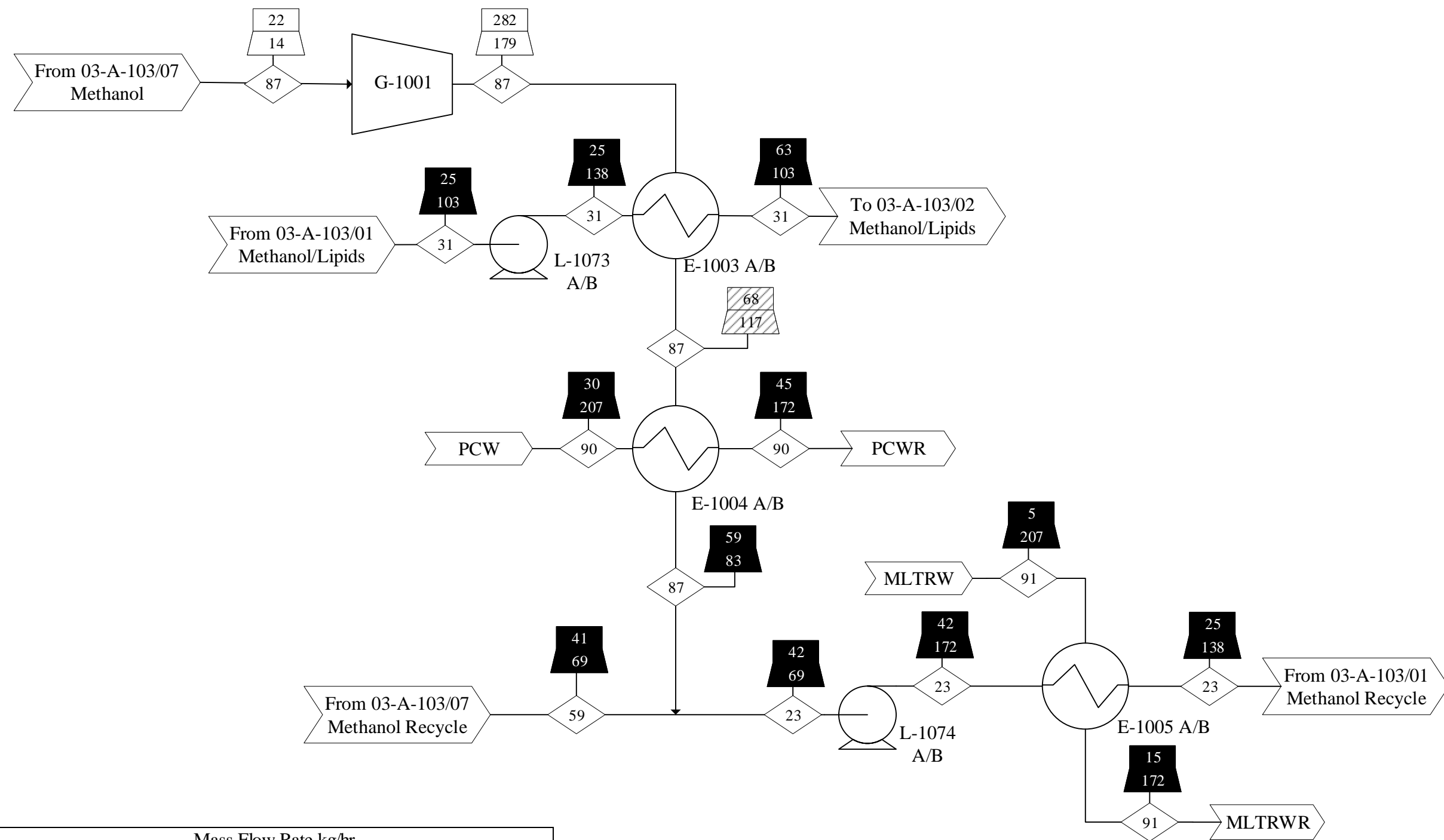

Mass Flow Rate kg/hr						
Stream	23	31	59	87	90	91
Lipids	Trace	59	Trace	Trace	0	0
Methanol	2900	3000	2700	280	0	0
BBM	Trace	0.24	Trace	Trace	0	0
Water	Trace	68	Trace	Trace	3400	2700
Total	2900	3100	2700	280	3400	2700

## APPENDIX J: GROWTH MEDIA REQUIREMENTS

*J.1: Bolds Basal Media*

Sodium Nitrate <sup>6</sup>	25 g
Calcium Chloride <sup>7</sup>	2.5 g
Magnesium Sulfate <sup>8</sup>	7.5 g
Dipotassium Hydrogen Phosphate <sup>9</sup>	7.5 g
Potassium Dihydrogen Phosphate <sup>10</sup>	17.5 g
Sodium Chloride <sup>11</sup>	2.5 g
Trace Element Solution** <sup>12</sup>	
Zinc Sulfate	8.8 mg
Manganese Chloride	1.4 mg
Molybdenum Trioxide	0.71 mg
Copper Sulfate	1.6 mg
Cobalt Nitrate	0.49 mg
EDTA <sup>12</sup>	9.3 mg
Acidified Iron Stock Solution <sup>13</sup>	3 mg
Boric Acid <sup>14</sup>	5.7 mg
Distilled Water	1 L

*J.2: Heterotrophic Basal Media*

Calcium Chloride <sup>7</sup>	25 mg
Magnesium Sulfate <sup>8</sup>	0.3 g
Dipotassium Hydrogen Phosphate <sup>9</sup>	0.3 g
Potassium Dihydrogen Phosphate <sup>10</sup>	0.7 g
Sodium Chloride <sup>11</sup>	25 mg
Trace Element Solution** <sup>12</sup>	
Zinc Sulfate	8.8 mg
Manganese Chloride	1.4 mg
Molybdenum Trioxide	0.71 mg
Copper Sulfate	1.6 mg
Cobalt Nitrate	0.49 mg
Sucrose <sup>15</sup>	40 g
Yeast Extract <sup>16</sup>	4 g
Acidified Iron Stock Solution <sup>13</sup>	3 mg
Distilled Water	1 L

APPENDIX K: CHAPTER 3 HPLC RESULTS

Appendix K.1 High Performance Liquid Chromatography Heterotrophic Basal Media Chromatogram

K.1.1:  $\text{NaNO}_3$  Chromatogram

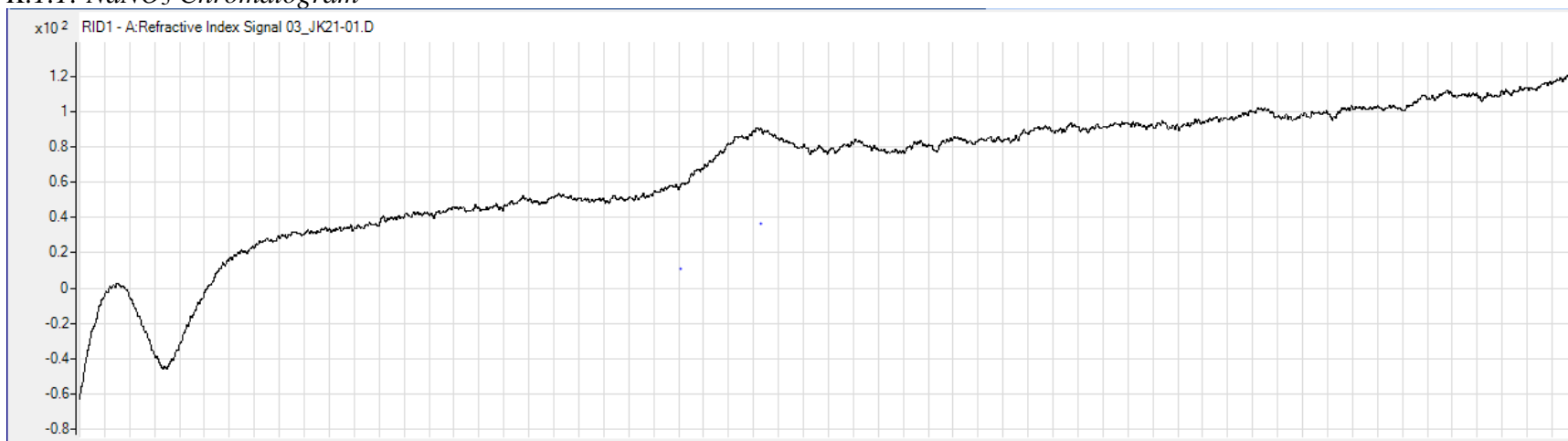

K.1.2:  $\text{CaCl}_2$  Chromatogram

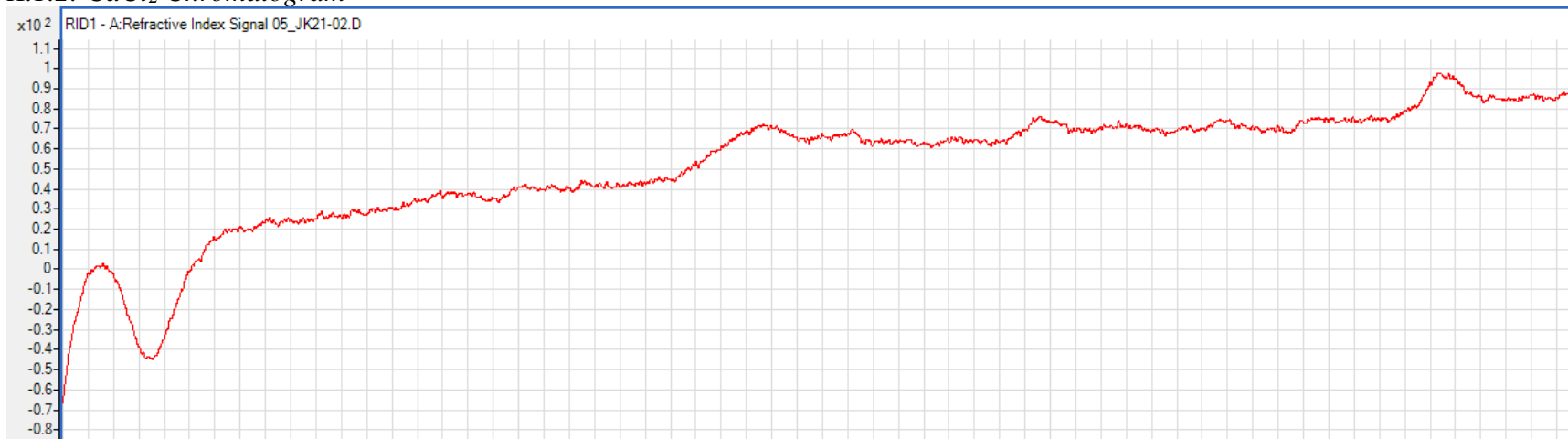

*K.1.3: MgSO<sub>4</sub> Chromatogram*

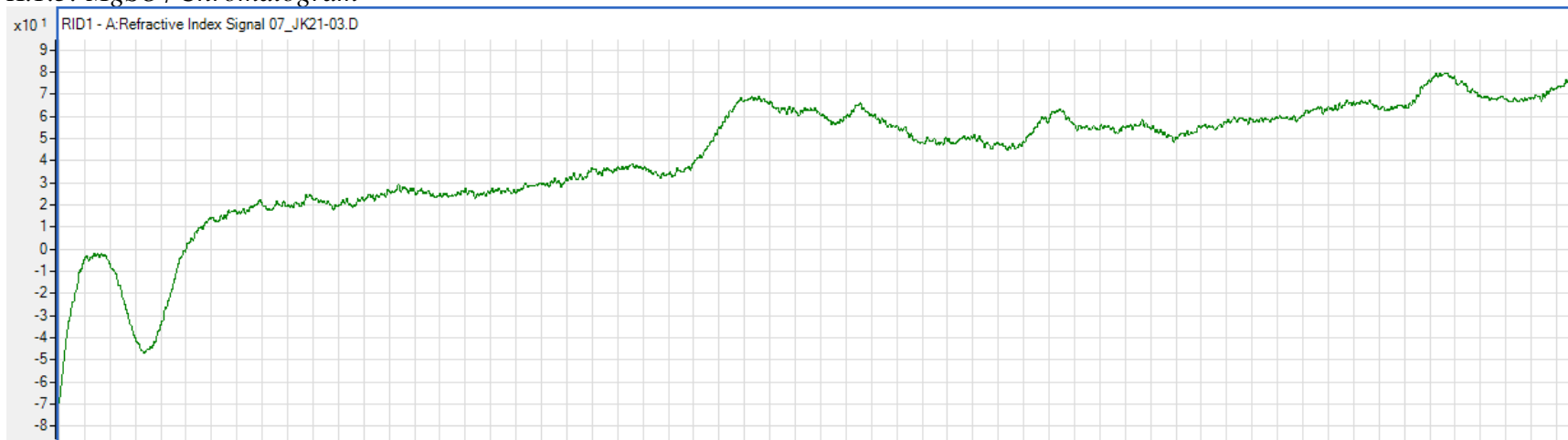

*K.1.4: K<sub>2</sub>HPO<sub>4</sub> Chromatogram*

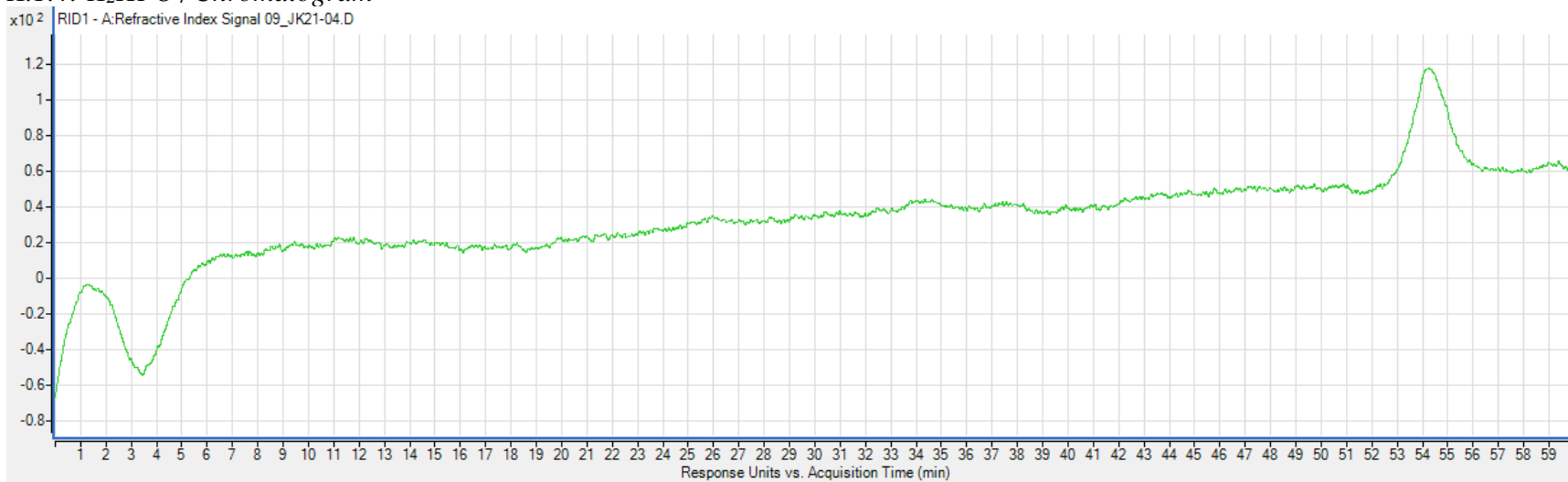

### K.1.5: $KH_2PO_4$ Chromatogram

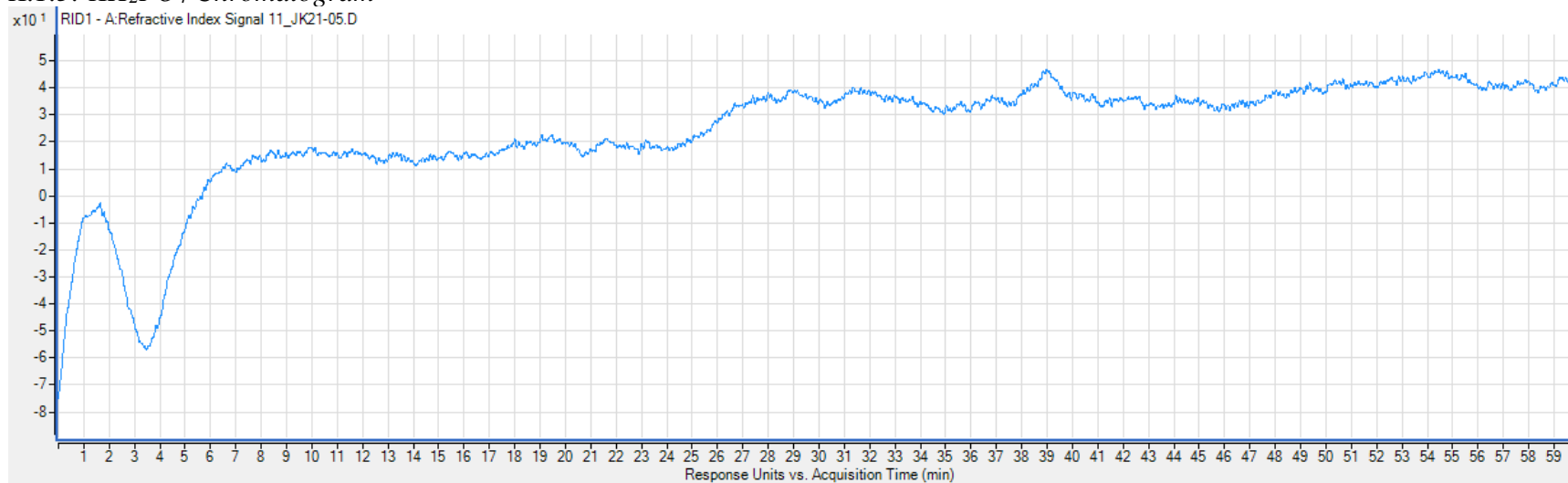

### K.1.6: $NaCl$ Chromatogram

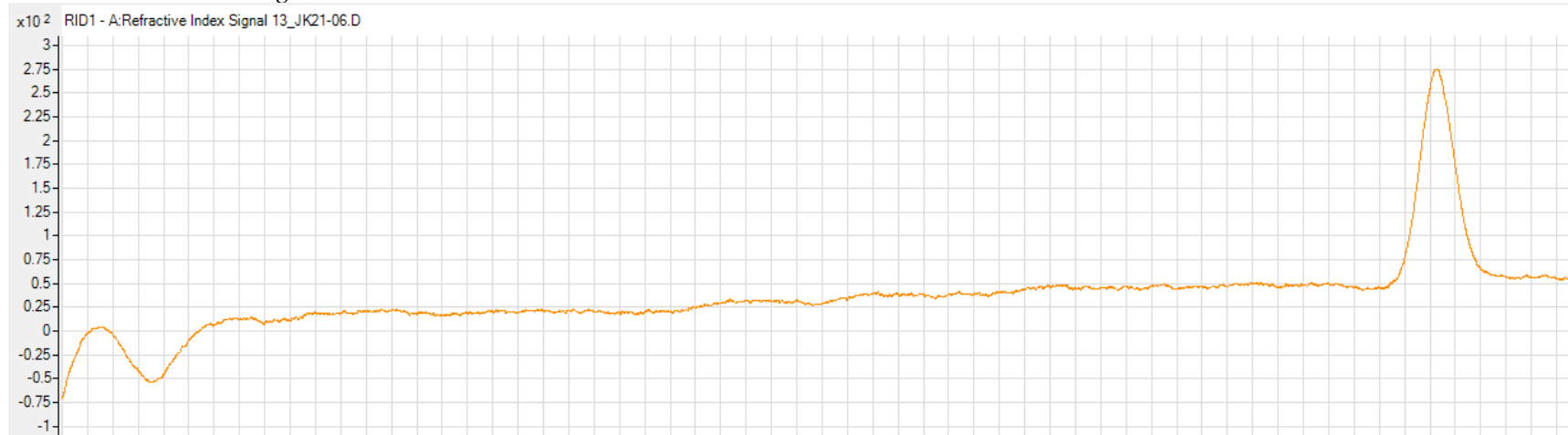

### K.1.7: EDTA Stock Solution Chromatogram

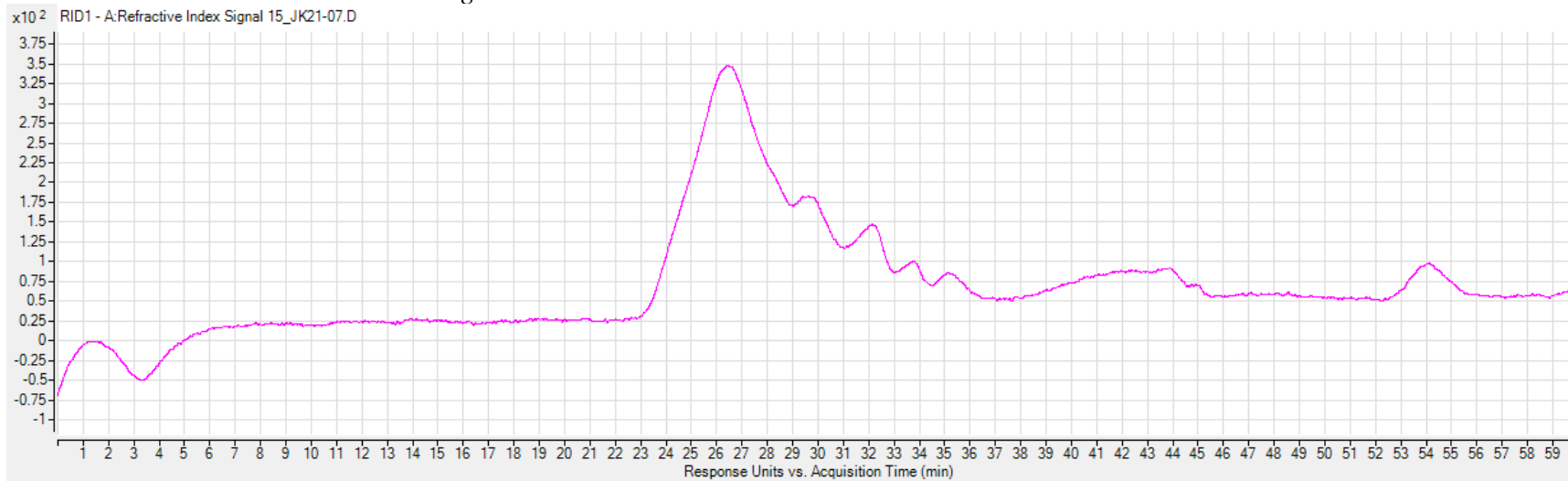

### K.1.8: Iron Stock Solution Chromatogram

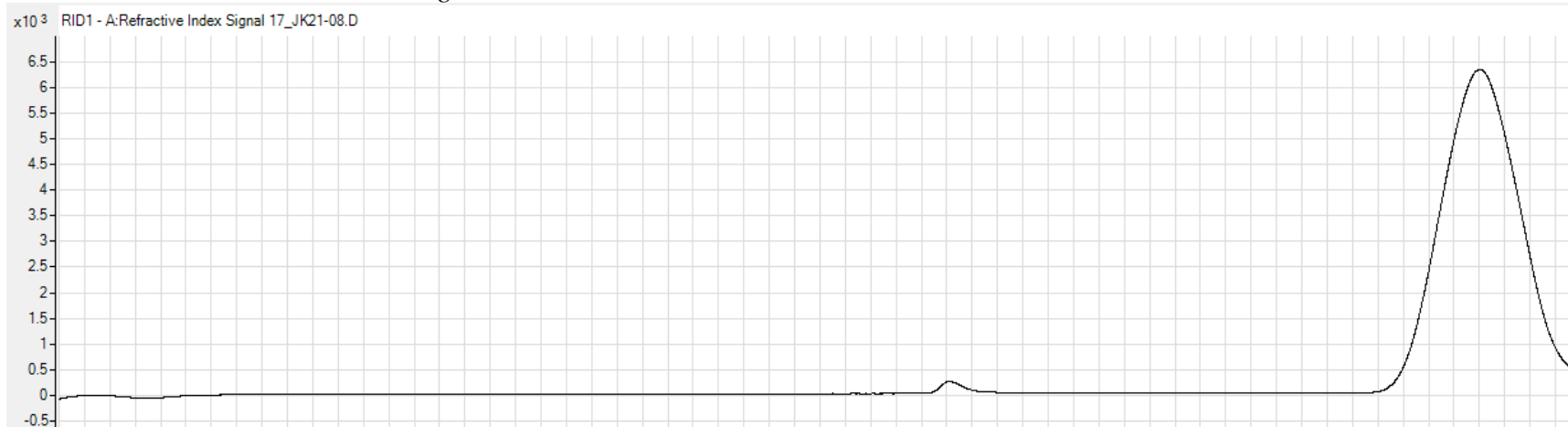



*K.1.9: Boron Stock Solution Chromatogram*

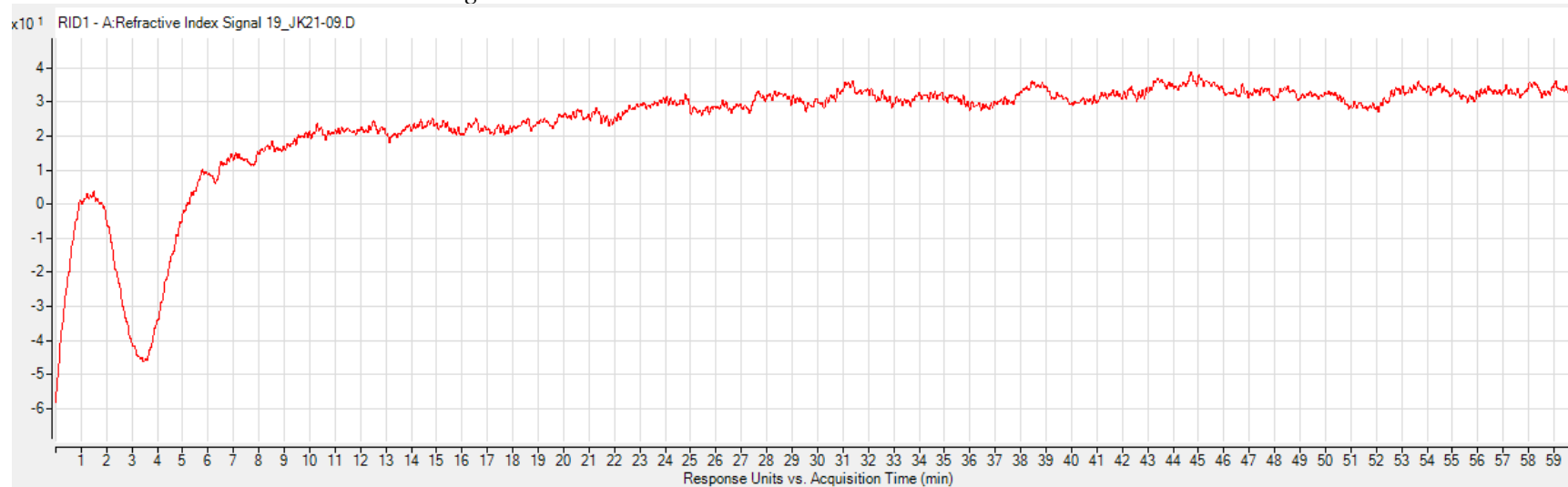

*K.1.10: Trace Metals Solution Chromatogram*

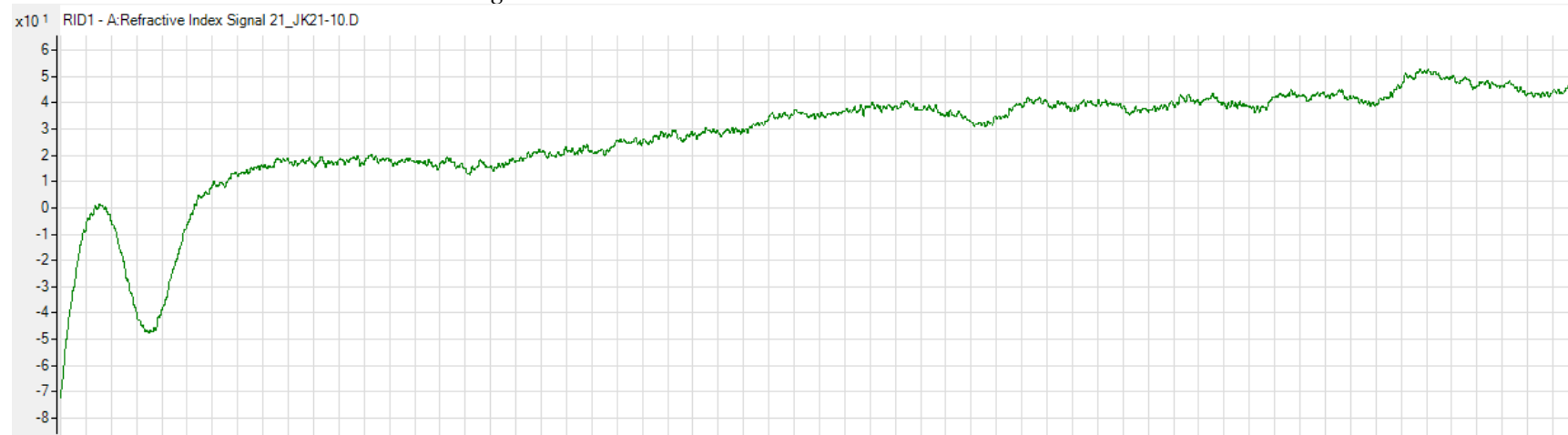

*K.1.11: FeSO<sub>4</sub> Chromatogram*

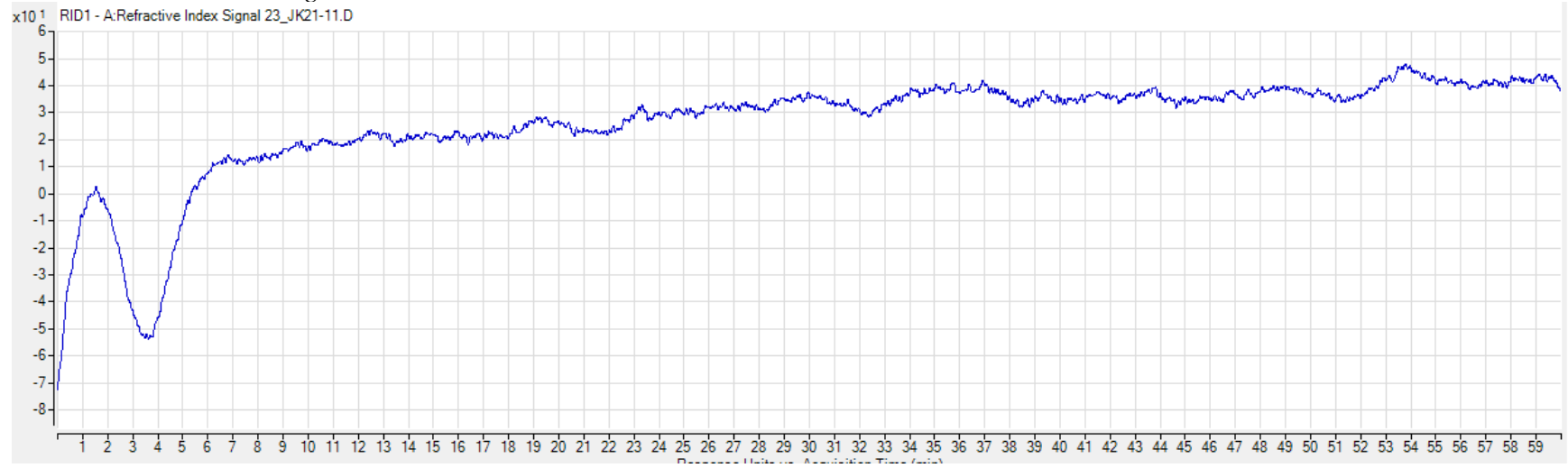

APPENDIX L: CHAPTER 4 OIL EXTRACTION PROTOCOL

### *Appendix L.1 Grinding Study Procedure*

The first factor tested was the ball mill grinding speed. A German Retsch MP100 Planetary Ball Mill, was used in conjunction with samples of the University of Leeds microalgae at 200, 300, 400, 500, and 600 rpm. Three samples of microalgae containing approximately 1g each at each grinding speed were weighed and inserted into quartz vessels. Each experimental trial in the triplicate set was performed simultaneously, with each triplicate set being performed subsequently in order of increasing ball mill grinding speed.

Triplicate extraction experiments were conducted with each of the three solvents (ethanol, hexane, and methanol) using samples generated at each grinding speed. 10 mL of solvent was combined with the microalgae in a fashion to evenly suspend the microalgae in the solution. The quartz vessel was inserted into the polytetrafluoroethylene reaction vessel and capped. The microalgae and solvent were allowed to be in contact for 25 minutes. After 25 minutes, the quartz vessel was removed from the polytetrafluoroethylene reaction vessel and emptied into a pre-weighed 12.5-centimeter double ring 102 filter paper. The vessel was rinsed with additional solvent to remove all residual microalgae from the vessel. The liquid was collected in a pre-weighed container. The containers of liquid were dried in a drying oven at 50°C until all the solvent had evaporated. The filter with the residual microalgae was also dried in a drying oven at 50°C until any residual solvent had evaporated. The weight of the filter and the container after drying were recorded to determine the total residual microalgae and extractant.

### *Appendix L.2 Microalgae to Solvent Ratio Study Procedure*

The second factor tested was the solvent to microalgae ratio, which was studied in three experimental phases. In the first phase, microwave-facilitated extraction was performed at an extraction temperature of 80°C using microalgae that was ground at 500 rpm to evaluate the effect of solvent-to-microalgae ratio on extraction efficiency. The following solvent to microalgae ratios were studied: 3:1, 7:1, 10:1, 11:1, 15:1, and 19:1.

Three samples of microalgae containing approximately 1g each were weighed out and inserted into quartz vessels. Each experimental trial in the triplicate set for each solvent-to-microalgae ratio was performed simultaneously, with each triplicate set being performed subsequently in increasing order. A triplicate at each solvent-to-microalgae ratio was performed for each of the three solvents (ethanol, hexane and methanol). Solvent was combined with the microalgae in a fashion to evenly suspend the microalgae in the solution. A magnetic stirring bar was inserted into the solution to maintain the suspension. The quartz vessel was inserted into the polytetrafluoroethylene reaction vessel and capped. The vessel was attached and secured to the carousel inside the microwave. The microwave program allotted 5 minutes for heating up to temperature, 10 minutes at temperature, and 10 minutes for cool down. After the 25-minute microwave program had finished, the quartz vessel was removed from the microwave carousel and the polytetrafluoroethylene reaction vessel.

In a second phase of experiments solvent extraction was explored at a temperature of 50°C in the sonicator using microalgae ground at 500 rpm to determine the effect of solvent-to-microalgae ratio during extraction. The following solvent-to-microalgae ratios were studied: 7:1, 8:1, 9:1, 10:1, and 11:1.

Three samples of microalgae containing approximately 1g each were weighed out and inserted into borosilicate test tubes. Each experimental trial in the triplicate set for each solvent-to-microalgae ratio was performed simultaneously, with each triplicate set being performed subsequently in increasing order. A triplicate at each solvent-to-microalgae ratio was performed for each of the three solvents. Solvent was combined with the microalgae in a fashion to evenly suspend the microalgae in the solution. The test tubes were capped with rubber stoppers to avoid any evaporation of the solvent during experimentation. The set of three test tubes was placed in a test tube rack in the sonicator. The microalgae and solvent were allowed to be in contact for 25 minutes in the sonicator. After 25 minutes, the test tubes were removed from the test tube rack.

The third phase of experimentation explored solvent extraction at 200°C using microalgae ground at 500 rpm in the small Batch Reactor to determine the effect of solvent-to-microalgae ratio during extraction. The following solvent to microalgae ratios were studied: 8:1, 8.5:1, 9:1, 9.5:1, and 10:1.

Three samples of microalgae containing approximately 1g each were weighed out for each ratio respectively and inserted into a 300 mL capacity stainless steel tube with nut and ferrule cap fitting to enclose each vessel. A smaller quantity of microalgae was used due to the size constraints of the experimental apparatus. The total volume of solvent and mass of microalgae varied with each ratio in order to avoid exceeding 75% of the available volume in each small reactor tube. Each experimental trial in the triplicate set for each solvent-to-microalgae ratio was performed simultaneously, with each triplicate set being performed subsequently in increasing order. Each triplicate was only performed with a single solvent, methanol.

The solvent was combined with the microalgae in a fashion to evenly suspend the microalgae in the solution. The batch reactor was allotted 5 minutes for heating up to temperature, 10 minutes at temperature, and 10 minutes for cool down. After the 25-minute microwave program had finished, the stainless-steel vessel was removed from the reactor carousel.

After the experimental procedure had been completed in each of the three phases, the solutions were emptied onto a pre-weighed 12.5-centimeter double ring 102 filter paper. The reaction vessels were rinsed with additional solvent to remove all residual microalgae from the vessels. The liquid was collected in a pre-weighed container. The containers of liquid were dried in a drying oven at 50°C until all the solvent had evaporated. The filter with the residual microalgae was also dried in a drying oven at 50°C until the solvent had evaporated. The weight of the filter and the container after drying were recorded to determine the total residual microalgae and the extracted microalgae.

#### *Appendix L.3 Microwave Study Procedure*

The third factor tested was microwave facilitated extraction across several temperature profiles. These experiments utilized microalgae ground at 500 rpm to determine the combined effect of microwave and temperature during extraction. The following temperatures were evaluated during the extraction: 25, 50, 80, 110, and 140°C.

Three samples of microalgae containing approximately 1g each were weighed out and inserted into quartz vessels with magnetic stirring bars to be run at each temperature setting. Each experimental trial in the triplicate set for each temperature was performed simultaneously, with each triplicate set being performed subsequently in order of

increasing temperature. A triplicate at each temperature setting was performed for each of the three solvents, ethanol, hexane and methanol. 10 mL of solvent was combined with the microalgae in a fashion to evenly suspend the microalgae in the solution. The quartz vessel was inserted into the polytetrafluoroethylene reaction vessel and capped. The vessel was attached and secured to the carousel inside the microwave. The microwave program allotted 5 minutes for heating up to temperature, 10 minutes at temperature, and 10 minutes for cool down. After the 25-minute microwave program had finished, the quartz vessel was removed from the microwave carousel and the polytetrafluoroethylene reaction vessel.

The solution was emptied onto a pre-weighed 12.5-centimeter double ring 102 filter paper. The vessel was rinsed with additional solvent to remove all residual microalgae from the vessel. The liquid was collected into a pre-weighed container. The containers of liquid were dried in a drying oven at 50 °C until all the solvent had evaporated. The filter with the residual microalgae was also dried in a drying oven at 50 °C until the solvent had evaporated. The weight of the filter and the container after drying were recorded to determine the total residual microalgae and the extracted solids.

#### *Appendix L.4 Sonication Study Procedure*

The fourth factor tested was sonication-facilitated extraction. These experiments utilized microalgae ground at 500 rpm and an extraction temperature of 25 °C in the sonicator to determine the effect of sonication on solvent extraction efficiency.

Three samples of microalgae containing approximately 1g each were weighed out and inserted into borosilicate test tube. Each experimental trial in the triplicate set for each sonication facilitated extraction was performed simultaneously. A triplicate at each



solvent-to-microalgae ratio was performed for each of the three solvents, ethanol, hexane and methanol. Solvent was combined with the microalgae in a fashion to evenly suspend the microalgae in the solution. The test tubes were capped with rubber stoppers to avoid any evaporation of the solvent during experimentation.

The set of three test tubes was placed in a test tube rack in the sonicator. The microalgae and solvent were allowed to be in contact for 25 minutes in the sonicator. After 25 minutes, the test tubes were removed from the test tube rack. After the experimental procedure had been completed in each of the three phases, the solution was emptied onto a pre-weighed 12.5-centimeter double ring 102 filter paper. The reaction vessel was rinsed with additional solvent to remove all residual microalgae from the vessel. The liquid was collected into a pre-weighed container. The containers of liquid were dried in a drying oven at 50 °C until all the solvent had evaporated. The filter with the residual microalgae was also dried in a drying oven at 50 °C until the solvent had evaporated. The weight of the filter and the container after drying were recorded to determine the total residual microalgae and the extracted microalgae.

#### *Appendix L.5 Temperature Study Procedure*

The fifth factor tested was temperature-facilitated extraction, which was completed in two phases. The first phase looked at a broad range of temperatures while the second phase investigated a narrower range of temperatures to determine the near optimum conditions. For both phases the microalgae were ground at 500 rpm. During the first phase, the following temperatures were examined during the extraction: 25, 80, 140, 200, and 230 °C while 150, 170, 190, 210, and 220°C were examined during the second phase.

Three samples of microalgae for each temperature were mixed with solvent in the ratio of 10 mL of solvent to 1g microalgae and inserted into a capped 300 mL capacity stainless steel tube. Each experimental trial in the triplicate set for each solvent to microalgae ratio was performed simultaneously, with each triplicate set being performed subsequently in increasing order. Each triplicate was only performed with a single solvent, methanol.

The solvent was combined with the microalgae in a fashion to evenly suspend the microalgae in the solution. The batch reactor followed a 25-minute program with 5 minutes for heating, 10 minutes at temperature, and 10 minutes for cool down. After the experimental procedure had been completed in each of the three phases, the solution was emptied onto a pre-weighed 12.5-centimeter double ring 102 filter paper. The reaction vessel was rinsed with additional solvent to remove all residual microalgae from the vessel. The liquid was collected into a pre-weighed container. The containers of liquid were dried in a drying oven at 50 °C until all the solvent had evaporated. The filter with the residual microalgae was also dried in a drying oven at 50 °C until the solvent had evaporated. The weight of the filter and the container after drying were recorded to determine the total residual microalgae and the extracted microalgae.

The sixth factor tested was in situ transesterification-facilitated extraction. Microalgae ground at 500 rpm were utilized and the extraction temperature was held constant at 80°C in the microwave, and the solvent to microalgae ratio was held constant at a 10:1 ratio. A drop of hydrochloric acid (HCl) was added to each solution to generate esters through in situ transesterification. Three samples of microalgae containing approximately 1g each were inserted into quartz vessels to be run. Each experimental

trial in the triplicate set for experimental condition was performed simultaneously, with each triplicate set being performed subsequently in increasing order. A triplicate at each solvent to microalgae ratio was performed for two solvents, ethanol and methanol.

Solvent was combined with the microalgae in a fashion to evenly suspend the microalgae in the solution. A magnetic stirring bar was inserted into the solution. The quartz vessel was inserted into the polytetrafluoroethylene reaction vessel and capped. The vessel was attached and secured to the carousel inside the microwave. The microwave program allotted 5 minutes for heating up to temperature, 10 minutes at temperature, and 10 minutes for cooldown. After the 25-minute microwave program had finished, the quartz vessel was removed from the microwave carousel and the polytetrafluoroethylene reaction vessel.

After the experimental procedure had been completed, the solutions were emptied onto a pre-weighed 12.5-centimeter double ring 102 filter paper. The reaction vessels were rinsed with additional solvent to remove all residual microalgae from the vessels. The liquid was collected in a pre-weighed container. The containers of liquid were dried in a drying oven at 50 °C until all the solvent had evaporated. The filter with the residual microalgae was also dried in a drying oven at 50 °C until the solvent had evaporated. The weight of the filter and the container after drying were recorded to determine the total residual microalgae and the extracted microalgae.

#### *Appendix L.6 In-Situ Transesterification Study Procedure*

The sixth factor tested was in-situ transesterification facilitated extraction using two feedstocks, University of Leeds autotrophic *Chlorella Vulgaris* and University of North

Dakota heterotrophic *Chlorella Vulgaris*. These experiments utilized microalgae ground at 500 rpm to determine the combined effect of microwave at 80°C and in-situ transesterification during extraction.

Three samples of microalgae containing approximately 1g each were weighed out and inserted into quartz vessels with magnetic stirring bars to be run at each temperature setting with a drop of HCl. Each experimental trial in the triplicate set for each temperature was performed simultaneously, with each triplicate set being performed subsequently in order of increasing temperature. A triplicate with each feedstock was performed for each of the two solvents, ethanol and methanol. 10 mL of solvent was combined with the microalgae in a fashion to evenly suspend the microalgae in the solution. The quartz vessel was inserted into the polytetrafluoroethylene reaction vessel and capped. The vessel was attached and secured to the carousel inside the microwave. The microwave program allotted 5 minutes for heating up to temperature, 10 minutes at temperature, and 10 minutes for cool down. After the 25-minute microwave program had finished, the quartz vessel was removed from the microwave carousel and the polytetrafluoroethylene reaction vessel.

The solution was emptied onto a pre-weighed 12.5-centimeter double ring 102 filter paper. The vessel was rinsed with additional solvent to remove all residual microalgae from the vessel. The liquid was collected into a pre-weighed container. The containers of liquid were dried in a drying oven at 50 °C until all the solvent had evaporated. The filter with the residual microalgae was also dried in a drying oven at 50 °C until the solvent had evaporated. The weight of the filter and the container after drying were recorded to determine the total residual microalgae and the extracted solids.

APPENDIX M: CHAPTER 4 OIL EXTRACTION EXPERIMENT LIST

*Table M.1. Microalgae Oil Extraction Experiment List*

<b>Experiment</b>	<b>Microalgae Type</b>	<b>Solvent</b>	<b>Mill Grinding Speed</b>	<b>Solvent to Microalgae Ratio</b>	<b>Temperature</b>	<b>Microwave</b>	<b>Oven</b>	<b>Sonicator</b>	<b>In-Situ Transesterification</b>
1	UoL Autotrophic	Methanol	200	10:1	25°C	-	-	-	-
2	UoL Autotrophic	Methanol	300	10:1	25°C	-	-	-	-
3	UoL Autotrophic	Methanol	400	10:1	25°C	-	-	-	-
4	UoL Autotrophic	Methanol	500	10:1	25°C	-	-	-	-
5	UoL Autotrophic	Methanol	600	10:1	25°C	-	-	-	-
6	UoL Autotrophic	Ethanol	200	10:1	25°C	-	-	-	-
7	UoL Autotrophic	Ethanol	300	10:1	25°C	-	-	-	-
8	UoL Autotrophic	Ethanol	400	10:1	25°C	-	-	-	-
9	UoL Autotrophic	Ethanol	500	10:1	25°C	-	-	-	-
10	UoL Autotrophic	Ethanol	600	10:1	25°C	-	-	-	-
11	UoL Autotrophic	Hexane	200	10:1	25°C	-	-	-	-
12	UoL Autotrophic	Hexane	300	10:1	25°C	-	-	-	-
13	UoL Autotrophic	Hexane	400	10:1	25°C	-	-	-	-
14	UoL Autotrophic	Hexane	500	10:1	25°C	-	-	-	-
15	UoL Autotrophic	Hexane	600	10:1	25°C	-	-	-	-
16	UoL Autotrophic	Methanol	500	3:1	80°C	+	-	-	-
17	UoL Autotrophic	Methanol	500	7:1	80°C	+	-	-	-
18	UoL Autotrophic	Methanol	500	10:1	80°C	+	-	-	-
19	UoL Autotrophic	Methanol	500	11:1	80°C	+	-	-	-
20	UoL Autotrophic	Methanol	500	15:1	80°C	+	-	-	-

21	UoL Autotrophic	Methanol	500	19:1	80°C	+	-	-	-
22	UoL Autotrophic	Ethanol	500	3:1	80°C	+	-	-	-
23	UoL Autotrophic	Ethanol	500	7:1	80°C	+	-	-	-
24	UoL Autotrophic	Ethanol	500	10:1	80°C	+	-	-	-
25	UoL Autotrophic	Ethanol	500	11:1	80°C	+	-	-	-
26	UoL Autotrophic	Ethanol	500	15:1	80°C	+	-	-	-
27	UoL Autotrophic	Ethanol	500	19:1	80°C	+	-	-	-
28	UoL Autotrophic	Hexane	500	3:1	80°C	+	-	-	-
29	UoL Autotrophic	Hexane	500	7:1	80°C	+	-	-	-
30	UoL Autotrophic	Hexane	500	10:1	80°C	+	-	-	-
31	UoL Autotrophic	Hexane	500	11:1	80°C	+	-	-	-
32	UoL Autotrophic	Hexane	500	15:1	80°C	+	-	-	-
33	UoL Autotrophic	Hexane	500	19:1	80°C	+	-	-	-
34	UoL Autotrophic	Methanol	500	7:1	25°C	-	-	+	-
35	UoL Autotrophic	Methanol	500	8:1	25°C	-	-	+	-
36	UoL Autotrophic	Methanol	500	9:1	25°C	-	-	+	-
37	UoL Autotrophic	Methanol	500	10:1	25°C	-	-	+	-
38	UoL Autotrophic	Methanol	500	11:1	25°C	-	-	+	-
39	UoL Autotrophic	Ethanol	500	7:1	25°C	-	-	+	-
40	UoL Autotrophic	Ethanol	500	8:1	25°C	-	-	+	-
41	UoL Autotrophic	Ethanol	500	9:1	25°C	-	-	+	-
42	UoL Autotrophic	Ethanol	500	10:1	25°C	-	-	+	-
43	UoL Autotrophic	Ethanol	500	11:1	25°C	-	-	+	-
44	UoL Autotrophic	Hexane	500	7:1	25°C	-	-	+	-
45	UoL Autotrophic	Hexane	500	8:1	25°C	-	-	+	-

46	UoL Autotrophic	Hexane	500	9:1	25°C	-	-	+	-
47	UoL Autotrophic	Hexane	500	10:1	25°C	-	-	+	-
48	UoL Autotrophic	Hexane	500	11:1	25°C	-	-	+	-
49	UoL Autotrophic	Methanol	500	8:1	25°C	-	-	+	-
50	UoL Autotrophic	Methanol	500	8.5:1	25°C	-	-	+	-
51	UoL Autotrophic	Methanol	500	9:1	25°C	-	-	+	-
52	UoL Autotrophic	Methanol	500	9.5:1	25°C	-	-	+	-
53	UoL Autotrophic	Methanol	500	10:1	25°C	-	-	+	-
54	UoL Autotrophic	Methanol	500	10:1	80°C	+	-	-	+
55	UoL Autotrophic	Ethanol	500	10:1	80°C	+	-	-	+
56	UND Heterotrophic	Methanol	500	10:1	80°C	+	-	-	+
57	UND Heterotrophic	Ethanol	500	10:1	80°C	+	-	-	+
58	UoL Autotrophic	Methanol	500	10:1	25°C	+	-	-	-
59	UoL Autotrophic	Methanol	500	10:1	50°C	+	-	-	-
60	UoL Autotrophic	Methanol	500	10:1	80°C	+	-	-	-
61	UoL Autotrophic	Methanol	500	10:1	110°C	+	-	-	-
62	UoL Autotrophic	Methanol	500	10:1	140°C	+	-	-	-
63	UoL Autotrophic	Ethanol	500	10:1	25°C	+	-	-	-
64	UoL Autotrophic	Ethanol	500	10:1	50°C	+	-	-	-
65	UoL Autotrophic	Ethanol	500	10:1	80°C	+	-	-	-
66	UoL Autotrophic	Ethanol	500	10:1	110°C	+	-	-	-
67	UoL Autotrophic	Ethanol	500	10:1	140°C	+	-	-	-
68	UoL Autotrophic	Hexane	500	10:1	25°C	+	-	-	-
69	UoL Autotrophic	Hexane	500	10:1	50°C	+	-	-	-
70	UoL Autotrophic	Hexane	500	10:1	80°C	+	-	-	-



71	UoL Autotrophic	Hexane	500	10:1	110°C	+	-	-	-
72	UoL Autotrophic	Hexane	500	10:1	140°C	+	-	-	-
73	UoL Autotrophic	Methanol	500	10:1	25°C	-	+	-	-
74	UoL Autotrophic	Methanol	500	10:1	80°C	-	+	-	-
75	UoL Autotrophic	Methanol	500	10:1	200°C	-	+	-	-
76	UoL Autotrophic	Methanol	500	10:1	140°C	-	+	-	-
77	UoL Autotrophic	Methanol	500	10:1	150°C	-	+	-	-
78	UoL Autotrophic	Methanol	500	10:1	160°C	-	+	-	-
79	UoL Autotrophic	Methanol	500	10:1	170°C	-	+	-	-
80	UoL Autotrophic	Methanol	500	10:1	180°C	-	+	-	-
81	UoL Autotrophic	Methanol	500	9:1	160°C	-	+	-	-
82	UND Autotrophic	Methanol	500	9:1	160°C	-	+	-	-
83	UND Heterotrophic	Methanol	500	9:1	160°C	-	+	-	-

APPENDIX N: REFERENCES LIST

## N.1 References

1. Fishmans, D.; Majumdar, R.; Morello, J.; Pate, R.; Yang, J. *National Algal Biofuels Technology Roadmap*; U.S. Department of Energy: Biomass Program, 2010.
2. Rattanapoltee, P.; Kaewkannetra, P., Cultivation of microalga, *Chlorella vulgaris* under different auto–hetero–mixo trophic growths as a raw material during biodiesel production and cost evaluation. *Energy* **2014**, *78*, 4-8.
3. Sakarika, M.; Kornros, M., Kinetics of growth and lipids accumulation in *Chlorella vulgaris* during batch heterotrophic cultivation: Effect of different nutrient limitation strategies. *Bioresource Technology* **2017**, *243*.
4. Ye, Y.; Huang, Y.; Xia, A.; Fu, Q.; Liao, Q.; Zeng, W.; Zheng, Y.; Zhu, X., Optimizing culture conditions for heterotrophic-assisted photoautotrophic biofilm growth of *Chlorella vulgaris* to simultaneously improve microalgae biomass and lipid productivity. *Bioresource Technology* **2018**, *270*.
5. Hu, J.; Nagarajan, D.; Zhang, Q.; Chang, J.-S.; Lee, D.-J., Heterotrophic cultivation of microalgae for pigment production: A review. *Biotechnology Advances* **2018**, *36* (1).
6. Parsons, S.; Chuck, C. J.; McManus, M. C., Microbial lipids: Progress in life cycle assessment (LCA) and future outlook of heterotrophic algae and yeast-derived oils. *172* **2018**, 661-672.
7. Bwapwa, J. K.; Anandraj, A.; Trois, C., Possibilities for conversion of microalgae oil into aviation fuel: A review. *Renewable and Sustainable Energy Reviews* **2017**, *80*, 1345-1354.
8. Ray, M.; Kumar, N.; Kumar, V.; Negi, S.; Banerjee, C., Chapter 12 - Microalgae: A Way Forward Approach Towards Wastewater Treatment and Bio-Fuel Production. *Applied Microbiology and Bioengineering* **2019**, 229-243.
9. Milano, J.; Ong, H. C.; Masjiki, H. H.; Chong, W. T.; Lam, M. K.; Loh, P. K.; Vellayan, V., Microalgae biofuels as an alternative to fossil fuel for power generation. *Renewable and Sustainable Energy Reviews* **2016**, *58*, 180-197.
10. Mata, T. M.; A., M. A.; Caetano, N. S., Microalgae for biodiesel production and other applications: A review. *Renewable and Sustainable Energy Reviews* **2010**, *14* (1), 217-232.
11. Kreft, J.; Moe, E.; Garcia, N.; Ross, A.; Seames, W., Comparative Scoping Study Report for the Extraction of Microalgae Oils from Two Subspecies of *Chlorella Vulgaris*. Paper Pending.
12. Foerster, I.; Oleksik, J.; Ross, A.; Seames, W., Comparison of Lipid Extraction Solvents and Techniques from *Chlorella Vulgaris*. **Paper Pending**.
13. Ulrich, G. D.; Vasudevan, P. T., *Chemical Engineering Process Design and Economics: A Practical Guide*. 2nd ed.; Process Publishing: Durham, New Hampshire, 2004.
14. Cost Estimate Classification System – as Applied in Engineering, Procurement, and Construction for the Process Industries, AACE International Recommended Practice No. 18R-97, 2005.
15. Zuniga, C.; Chien-Ting, L.; Huelsman, T.; Levering, J.; Zielinski, D. C.; McConnell, B. O.; Long, C. P.; Knoshaug, E. P. G., Michael T.; Antoniewicz, M. R.; Betenbaugh, M. J.; Zengler, K., Genome-Scale Metabolic Model for the Green Alga *Chlorella vulgaris* UTEX 395

Accurately Predicts Phenotypes under Autotrophic, Heterotrophic, and Mixotrophic Growth Conditions. *American Society of Plant Biologists* **2016**.

16. Vaiciulyte, S.; Padovani, G.; Kostkeviciene, J.; Carozzi, P., Batch Growth of *Chlorella Vulgaris* CICALA 896 versus Semi-Continuous Regimen for Enhancing Oil-Rich Biomass Productivity. *Energies* **2014**, *7*, 3840-3857.

17. Information, N. C. f. B. Sucrose. <https://pubchem.ncbi.nlm.nih.gov/compound/sucrose> (accessed March).

18. Table of Solubility. <http://periodic-table-of-elements.org/SOLUBILITY> (accessed March).

19. Shuler, M. L.; Kargi, F., *Bioprocess Engineering: Basic Concepts*. Prentice Hall PTR: Upper Saddle River, New Jersey, 2010.

20. Turton, R.; Bailie, R. C.; Whiting, W. B.; Shaeiwitz, J. A.; Bhattacharyya, D., *Analysis, Synthesis, and Design of Chemical Process*. 4th ed.; Pearson: 2013.

21. Chemical Engineering Essentials for the CPI Professional. <https://www.chemengonline.com/> (accessed March).

22. Group, N.-C. Sugar Commodity Price. <https://www.indexmundi.com/commodities/?commodity=sugar> (accessed March).

23. Luckow, P.; al., e., Carbon Dioxide Price Forecast. 2015.

24. Law, J., Quote for EDTA. 2017.

25. Statistics, U. S. B. o. L. Chemical Plant and System Operators. <https://www.bls.gov/oes/2017/may/oes518091.htm> (accessed March).

26. Methanex Methanol Prices. <https://www.hulu.com/watch/e6a2d965-ac1d-4b55-9103-42c12068ab69> (accessed March).

27. Associates, C. H. Bio-Oil Commercialization Plan. (accessed March).

28. Davis, R.; Kinchin, C.; Markham, E. C. D. *Process Design and Economics for the Conversion of Algal Biomass to Biofuels: Algal Biomass Fractionation to Lipid and Carbohydrate-Derived Fuel Products*; 2014.

29. Thiesse, K. USDA Crop Predictions send corn and soybean prices lower from July Estimates. <https://www.farmprogress.com/blog/usda-crop-predictions-sends-corn-and-soybean-prices-lower-july-estimates>.

30. AgriNews Minn. beet yield hits 29.9 tons per acre. <http://www.sugarproducer.com/2015/11/minn-beet-yield-hits-299>.

31. Sheehan, J.; Dunahay, T.; Benemann, J.; Roessler, P. *A Look Back at the U.S. Department of Energy's Aquatic Species Program—Biodiesel from Algae*; U.S. Department of Energy's Office of Fuels Development: 1998; pp 1-328.

32. Voeller, K.; Bilek, H.; Kreft, J.; Dostalkova, A.; Kozliak, E.; Kubatova, A., Thermal Carbon Analysis Enabling Comprehensive Characterization of Lignin and Its Degradation Products. *ACS Sustainable Chemistry and Engineering* **2017**, *5* (11).

33. Ball, S.; Bullock, S.; Lloyd, L.; Mapp, K., Analysis of carbohydrates, alcohols, and organic acids by ion-exchange chromatography. Technologies, A., Ed. 2011.

34. Santillan-Jimenez, E.; Pace, R.; Marques, S.; Morgan, T.; McKelphin, C.; Mobley, J.; Crocker, M., Extraction, characterization, purification and catalytic upgrading of algae lipids to fuel-like hydrocarbons. *Fuel* **2016**, *180*, 668-678.
35. Kumar, K. S.; Prasanthkumar, S.; Ray, J. G., Experimental assessment of productivity, oil-yield and oil-profile of eight different common freshwater-blooming green algae of Kerala. *Biocatalysis and Agricultural Biotechnology* **2016**, *8*, 270-277.
36. Kumari, N.; Singh, R. K., Biofuel and co-products from algae solvent extraction. *Journal of Environmental Management* **2019**, *247*, 196-204.
37. Shi, R.; Handler, R. M.; Shonnard, D. R., Life cycle assessment of novel technologies for algae harvesting and oil extraction in the renewable diesel pathway. *Algal Research* **2019**, *37*, 248-259.
38. Menegazzo, M. L.; Fonseca, G. G., Biomass recovery and lipid extraction processes for microalgae biofuels production: A review. *Renewable and Sustainable Energy Reviews* **2019**, *107*, 87-107.
39. Li, P.; Sakuragi, K.; Makino, H., Extraction techniques in sustainable biofuel production: A concise review. *Fuel Processing Technology* **2019**, *193*, 295-303.
40. Deshmukh, S.; Kumar, R.; Bala, K., Microalgae biodiesel: A review on oil extraction, fatty acid composition, properties and effect on engine performance and emissions. *Fuel Processing Technology* **2019**, *191*, 232-247.
41. Cheng, M.-H.; Rosentrater, K. A., Economic feasibility analysis of soybean oil production by hexane extraction. *Industrial Crops and Products* **2017**, *108*, 775-785.
42. Cheng, M.-H.; Sekhon, J. J. K.; Rosentrater, K. A.; Wang, T.; Jung, S.; Johnson, L. A., Environmental impact assessment of soybean oil production: Extruding-expelling process, hexane extraction and aqueous extraction. *Food and Bioprocess Technology* **2018**, *108*, 55-68.
43. Viegas, C. V.; Hachemi, I.; Freitas, S. P.; Maki-Arvela, P.; Aho, A.; Hemming, J.; Smeds, A.; Heinmaa, I.; Fontes, F. B.; Cristina, d. S. P. D.; Kumar, N.; Aranda, D. A. G.; Murzin, D. Y., A route to produce renewable diesel from algae: Synthesis and characterization of biodiesel via in situ transesterification of *Chlorella* alga and its catalytic deoxygenation to renewable diesel. *Fuel* **2015**, *155*, 144-154.
44. Skorupskaite, V.; Makareviciene, V.; Gumbyte, M., Opportunities for simultaneous oil extraction and transesterification during biodiesel fuel production from microalgae: A review. *Fuel Processing Technology* **2016**, *150*, 78-87.
45. Lee, A. K.; Lewis, D. M.; Ashman, P. J., Disruption of microalgal cells for the extraction of lipids for biofuels: Processes and specific energy requirement. *Biomass and Bioenergy* **2012**, *46*, 89-101.
46. Milestone, StartSYNTH Microwave Synthesis Labstation.
47. Yew, G. Y.; Lee, S. Y.; Show, P. L.; Tao, Y.; Law, C. L.; Nguyen, T. T. C.; Chang, J.-S., Recent advances in algae biodiesel production: From upstream cultivation to downstream processing. *Bioresour. Technol.* **2019**, *7*.
48. Ranjan, A.; Patil, C.; Moholkar, V. S., Mechanistic Assessment of Microalgal Lipid Extraction. *Industrial and Engineering Chemistry Research* **2010**, *49* (6), 2979-2985.
49. Araujo, G. S.; Matos, L. J. B. L.; Fernandes, J. O.; Cartaxo, S. J. M.; Goncalves, L. R. B.; Fernandes, F. A. N.; Farias, W. R. L., Extraction of lipids from microalgae by ultrasound

- application: Prospection of the optimal extraction method. *Ultrasonics Sonochemistry* **2012**, *20* (1), 95-98.
50. Menendez, J. M. B.; Arenillas, A.; Diaz, J. A. M.; Boffa, L.; Mantegna, S.; Binello, A.; Cravotto, G., Optimization of microalgae oil extraction under ultrasound and microwave irradiation. *Journal of Chemical Technology and Biotechnology* **2013**, *89* (11).
51. Amarni, F.; Kadi, H., Kinetics study of microwave-assisted solvent extraction of oil from olive cake using hexane : Comparison with the conventional extraction. *Innovative Food Science and Emerging Technologies* **2010**, *11* (2), 332-327.
52. Ramola, B.; Kumar, V.; Nanda, M.; Mishra, Y.; Tyagi, T.; Gupta, A.; Sharma, N., Evaluation, comparison of different solvent extraction, cell disruption methods and hydrothermal liquefaction of *Oedogonium* macroalgae for biofuel production. *Biotechnology Reports* **2019**, *22*.
53. Veeranan, T.; Kasirajaan, R.; Gurunathan, B.; Sahadevan, R., A novel approach for extraction of algal oil from marine macroalgae *Ulva fasciata*. *Renewable Energy* **2018**, *127*, 64-73.
54. Chamola, R.; Khan, M. F.; Raj, A.; Verma, M.; Jain, S., Response surface methodology based optimization of in situ transesterification of dry algae with methanol, H<sub>2</sub>SO<sub>4</sub> and NaOH. *Fuel* **2012**, *239*, 511-520.
55. Potrich, E.; Miyoshi, S. C.; Machado, P. F. S.; Furlan, F. F.; Ribeiro, M. P. A.; Tardioli, P. W.; Giordano, R. L. C.; Cruz, A. J. G.; Giordano, R. C., Replacing hexane by ethanol for soybean oil extraction: Modeling, simulation, and techno-economic-environmental analysis. *Journal of Cleaner Production* **2020**, *244*.
56. Lima, D. G.; Soares, V. C. D.; Ribeiro, E. B.; Carvalho, D. A.; Cardoso, E. C. V; Rassi, F. C.; Mundim, K. C.; Rubim, J. C.; Suarez, P. A. Z., Diesel-Like Fuel Obtained by Pyrolysis of Vegetable Oils. *Journal of Analytical and Applied Pyrolysis* **2004**, 987-996.