

Technical Disclosure Commons

Defensive Publications Series

September 2020

Aluminum Cans for Slushed Beverages and Methods of Making Slushed Beverages in Aluminum Cans

Winfried Kiefer
Novelis Inc.

Shania Polson
Novelis Inc.

Alejandra Arango
Novelis Inc.

Tomas Oleksiak
Novelis Inc.

Jan-Tobias Pape
Novelis Inc.

See next page for additional authors

Follow this and additional works at: https://www.tdcommons.org/dpubs_series

Recommended Citation

Kiefer, Winfried; Polson, Shania; Arango, Alejandra; Oleksiak, Tomas; Pape, Jan-Tobias; Janoff, Anna; Dasch, Kyle; Roux, Mitchell; Topham, Chase; Das, Sazol; Ruparelia, Dhiren; Woods, Julia; Wagstaff, Samuel; Kadali, Jyothi; Kamp, Nicolas; Hegadekatte, Vishwanath; Campbell, Ian; and Wagstaff, Robert, "Aluminum Cans for Slushed Beverages and Methods of Making Slushed Beverages in Aluminum Cans", Technical Disclosure Commons, (September 09, 2020)
https://www.tdcommons.org/dpubs_series/3584



This work is licensed under a [Creative Commons Attribution 4.0 License](https://creativecommons.org/licenses/by/4.0/).

This Article is brought to you for free and open access by Technical Disclosure Commons. It has been accepted for inclusion in Defensive Publications Series by an authorized administrator of Technical Disclosure Commons.

Inventor(s)

Winfried Kiefer, Shania Polson, Alejandra Arango, Tomas Oleksiak, Jan-Tobias Pape, Anna Janoff, Kyle Dasch, Mitchell Roux, Chase Topham, Sazol Das, Dhiren Ruparelia, Julia Woods, Samuel Wagstaff, Jyothi Kadali, Nicolas Kamp, Vishwanath Hegadekatte, Ian Campbell, and Robert Wagstaff

ALUMINUM CANS FOR SLUSHED BEVERAGES AND METHODS OF MAKING SLUSHED BEVERAGES IN ALUMINUM CANS

FIELD

5 The present disclosure is directed to aluminum alloy products for slushed beverages. The disclosure further relates to methods of making slushed beverages in aluminum beverage cans.

BACKGROUND

10 Consumer demand for slushed beverages, commonly known as a slushy, slushie, or slushee, has increased. Slushed beverages include fine ice particles throughout the beverage that create a smooth texture while maintaining fluid properties, such as the capability of being poured into a container or transported through a straw. Some providers of slushed beverages utilize specialized equipment to prepare the mixture of fine ice and beverage. However, conventional equipment may not be feasible for individualized slushed beverages for a consumer, especially
15 for beverages in a metal can, including an aluminum beverage can.

 Metal cans are well known and widely used as beverage containers. However, obtaining a slushed beverage from a conventional metal beverage can has been difficult because the beverage often foams and explodes as soon as the container is opened. Other challenges with using conventional metal cans for slushed beverages include buildup of a thick ice layer on the
20 side wall of the can. Even when a slushed beverage is produced from the aluminum can, it can be too thick to drink and enjoy.

SUMMARY

25 Described herein is an aluminum alloy product for making a slushed beverage. In some examples, an aluminum beverage can for making a slushed beverage comprises an aluminum can body, comprising a dome and a sidewall, and a can end connected to the can body, comprising a scored opening and a tab configured to open the can end at the scored opening. The aluminum can body has an interior surface and an exterior surface. A first organic coating layer may contact an interior surface of the can body. A second organic coating layer may contact an
30 interior surface of the can end. In some examples, the first and/or second organic coating layers may comprise polyethylene terephthalate, polyamide, or polypropylene. In some cases, the first

and/or second organic coating layers may be laminated to the interior surfaces of the can body and can end. Optionally, the can may further comprise an organic coating layer on the exterior surface of the can body.

5 In some examples, the slushed beverage may comprise at least one of soda, juice, milk, coffee, and tea. In other examples, the slushed beverage may comprise at least one of beer, liquor, and wine. In certain examples, the slushed beverage may comprise sports drinks or nutritional supplements.

10 In some examples, an aluminum beverage can for making a slushed beverage may comprise a hydrophobic coating on the can body. In certain examples, the aluminum beverage can end may also comprise a hydrophobic coating. In some examples, a hydrophobic coating may increase the contact angle of the beverage and the aluminum beverage can wall by at least 50°. In other examples, the hydrophobic coating may increase the contact angle of the beverage and the aluminum beverage can wall by at least 80°. In some examples, the hydrophobic coating may comprise a fatty acid, such as lauric acid.

15 In certain examples, the aluminum beverage can may further include a nucleation device, where the device is attached to the dome on the interior of the can body. In some cases, the device comprises a gas and is configured to release the gas into the beverage upon opening the aluminum can. In some cases, the gas within the device can comprise nitrogen or carbon dioxide. In other cases, the gas within the device may comprise an inert gas. Optionally, the nucleation
20 device may comprise nucleation particles configured to release into the beverage upon opening the aluminum can. In certain cases, nucleation particles may be introduced in the beverage from an external source such as a straw or stir stick coated with the particles. In some cases, the nucleation particles comprise at least one of sugar, acesulfame potassium (acesulfame K), advantame, aspartame, neotame, saccharin, stevia, sucralose, and other sugar substitutes. In some
25 cases, the particles can have a length of about 1 mm to about 5 mm. In some cases, the particles can be in a dried form. For example, the particles can have a water content below 1 weight percent. In some examples, the particles can be crystalline in nature and provide for rapid crystal growth.

30 Also described herein is a method of making a slushed beverage. The method may comprise cooling a beverage in an aluminum beverage can to below 0 °C, wherein the aluminum beverage can comprises a can body and a can end coated with an organic coating layer as

described herein. The method can further include opening the aluminum beverage can and pouring the cooled beverage into a container.

The method can further include releasing a nucleation gas and/or nucleation particles into the beverage from a device comprising the gas, wherein the device is attached to a dome on the interior of the aluminum beverage can body. Optionally, the method may further comprise
5 introducing nucleation particles from an external implement into the beverage upon opening the aluminum beverage can. In some cases, the particles may be introduced into the beverage by inserting into the beverage a straw or stick coated with the particles. In some examples, the particles may comprise at least one of sugar, acesulfame potassium (acesulfame K), advantame,
10 aspartame, neotame, saccharin, stevia, sucralose, and other sugar substitutes. In some cases, the particles may have a length of about 1 mm to about 5 mm.

Optionally, the method may further comprise at least one of vibrating, rotating, or shaking the can before opening. In some examples, the aluminum beverage can may be oriented at an angle ranging from 30° to 90° from vertical and rotated about the longitudinal axis at a rate
15 of about 1000 rpm to about 1500 rpm. In other examples, the aluminum beverage can may be oriented approximately 45° from vertical and rotated about the longitudinal axis at a rate of about 1000 rpm to about 1500 rpm. Optionally, the rotation of the aluminum beverage can further comprises movement in a conical pattern such that the movement of a distal end of the can is greater than the movement of a proximal end of the can as measured substantially perpendicular
20 to the longitudinal axis of rotation (+/- 10° or less).

In some cases, the method can comprise cooling the aluminum beverage can in a coolant bath at a temperature ranging from about -20 °C to about -40 °C for about 20 seconds to about 120 seconds (e.g., -23 °C to -30 °C or -25 °C to -28 °C). Optionally, the can may be placed in a designed holder to orient and rotate the can during the cooling step. In some examples, the holder
25 can comprise fingers to grasp the can from a tabbed end or a domed end of the can. In certain examples, a liquid bath comprising a heat transfer fluid can be used to cool the aluminum beverage can. In some examples, heat transfer fluids in the DYNALENE line, commercially available from Dynalene, Inc. (Whitehall, Pennsylvania), can be used. In other examples, liquid nitrogen or carbon dioxide can be used to cool the aluminum beverage can.

30 Optionally, the method may further comprise rotating the aluminum beverage can for an additional rotational period, where the aluminum beverage can orientation may be different than

the orientation of the aluminum beverage can during the first rotation period, that is a first rotational orientation may be different than a second rotational orientation. For example, the aluminum beverage can may be rotated at 45° and then rotated at 90°. In some examples, the method can include transferring the aluminum beverage can to an ultrasonicator where the can is rotated in a substantially horizontal direction. By rotating the can in a substantially horizontal orientation, freezing of the liquid contents of the aluminum beverage can on the wall of the aluminum beverage can or bottom of the aluminum beverage can may be avoided as nucleation begins. In some examples, the ultrasonicator bath temperature can be from about 4 °C to about 10 °C. The rotation time of the aluminum beverage can may differ based on the viscosity of the contents. In some examples, the rotation time can be between about 10 seconds to about 120 seconds in the first bath at the first rotational orientation and can be between about 5 seconds and about 60 seconds in the ultrasonicator at the second rotational orientation.

Optionally, the method may comprise rotating at least one magnet, such as a diamagnetic magnet, adjacent to the rotating aluminum can, where the rotational direction of the magnet can be the same as the beverage can. In some cases, the magnet can be a rare earth magnet. For example, the magnet can comprise neodymium (Nd) and iron (Fe), such as a NdFeB magnet. In some cases, the alternating magnetic field generated by rotating the magnet can locally heat the walls of the aluminum beverage can through induction heating and substantially prevent formation of an ice layer at the interior wall of the aluminum can. Optionally, the method may comprise rotating a high frequency electromagnetic coil adjacent to the rotating aluminum can.

In some examples, the method may comprise placing the aluminum beverage can in a polymer sleeve prior to rotating the aluminum beverage can within the coolant bath. The polymer sleeve can modify the heat transfer rate between the coolant bath and the aluminum beverage can to substantially prevent formation of an ice layer at the interior wall of the aluminum beverage can.

Also described herein is a method of making a hydrophobic or non-wetting aluminum for an aluminum beverage can body or can end. The method can include contacting the aluminum beverage can body or can end in a solution that imparts the hydrophobic or non-wetting property to the can body or can end. In some cases, the method can comprise immersing the aluminum beverage can body or can end in a solution of potassium hydroxide (KOH) and a solution comprising a fatty acid. In some cases, the fatty acid can be lauric acid (C₁₂H₂₄O₂). In some

examples, the method can comprise immersing the aluminum beverage can body or can end in a KOH solution, rinsing the aluminum beverage can body or can end with deionized water, and immersing the aluminum beverage can body or can end in a fatty acid solution. Optionally, the method can comprise drying the aluminum beverage can body or can end after the fatty acid solution immersion. In other examples, the method can comprise immersing the aluminum beverage can body or can end in a solution comprising KOH and a fatty acid. In some examples, the immersion time of the aluminum beverage can body or can end in KOH can be about 5 minutes to about 60 minutes. In some examples, the immersion time of the aluminum beverage can body or can end in the fatty acid can be about 5 minutes to about 30 minutes. In other examples, the immersion time of the aluminum beverage can body or can end in the solution comprising KOH and the fatty acid can be about 5 minutes to about 30 minutes.

Other objects and advantages of the invention will be apparent from the following detailed description of non-limiting examples.

BRIEF DESCRIPTION OF THE FIGURES

FIG. 1 is an illustration of a temperature gradient of a chilled PET bottle compared to chilled aluminum beverage can.

FIG. 2A shows a top perspective of a conventional aluminum beverage can.

FIG. 2B shows a bottom perspective of a conventional aluminum beverage can.

FIG. 3 is an illustration of the side profile of a conventional aluminum beverage can.

FIG. 4 is an illustration of an aluminum beverage can with an organic coating on the interior of the can and an optional organic coating on the exterior of the can according to one disclosure described herein.

FIG. 5 shows the difference in droplet size (contact angle) in untreated aluminum as compared to superhydrophobic aluminum treated according to one disclosure described herein.

FIGS. 6A and 6B show an aluminum beverage can with a nucleation device in the dome according to one disclosure described herein.

FIG. 7 is an illustration of the temperature gradient of a beverage can that has been shaken or rotated while chilling according to one disclosure described herein.

FIG. 8 shows the longitudinal axis, the center of rotation, of an aluminum beverage can, according to one disclosure described herein.

FIG. 9 shows one example of a holder used to grasp the aluminum beverage can during rotation according to one disclosure described herein.

FIGS. 10A, 10B, and 10C show angles of rotation of an aluminum beverage can according to one disclosure described herein.

5 FIG. 11 is an illustration of conical movement of an aluminum beverage can during rotation according to one disclosure described herein.

FIG. 12 is an illustration of a rotating magnet adjacent to a rotating aluminum beverage can according to one disclosure described herein.

10 FIG. 13 is an illustration of vibrating an aluminum beverage can using a piezoelectric motor at the base of the can according to one disclosure described herein.

FIG. 14 is an illustration of the damping and expected nucleation in an aluminum beverage can as compared to a PET bottle.

FIG. 15 is an illustration of vibrating an aluminum beverage can at the base while the can is inverted according to one disclosure described herein.

15 FIG. 16 is an illustration of the placement of the acoustical energy on an inverted aluminum beverage can according to one disclosure described herein.

FIG. 17 is a micrograph of the surface of a conventional aluminum can.

FIG. 18 is a micrograph of the surface of a PET bottle.

20 FIG. 19 is a schematic of a method for making a hydrophobic surface on aluminum beverage cans according to one disclosure described herein.

FIG. 20 shows the change in contact angle based on treatment time and process steps according to one disclosure described herein.

FIG. 21 shows the change in contact angle after immersion in 3% NaCl solution.

25 DETAILED DESCRIPTION

Described herein are aluminum alloy products for slushed beverages, specifically, aluminum beverage cans for slushed beverages, and methods of making slushed beverages in aluminum beverage cans.

30 The heat transfer properties of aluminum may impede making slushed beverages within a conventional aluminum beverage can. As shown in FIG. 1, the temperature gradient in a conventional PET bottle (left panel) is much larger than the temperature gradient in a

conventional aluminum beverage can (right panel). As a result, chilling a beverage in a conventional aluminum beverage can may result in a frozen layer of ice or beverage at the can wall and fail to produce the desired slushed beverage with fine ice particles throughout the beverage that create a smooth texture. The aluminum alloy products and methods described
 5 herein overcome the challenges posed by the heat transfer and surface characteristics of a conventional aluminum beverage can.

In some examples, an aluminum beverage can may comprise an organic coating or a hydrophobic coating to substantially prevent ice formation at the walls of the can body. In some examples, a gas or nucleating particle can be used to form the slushed beverage. In some
 10 examples, a method can comprise rotating an aluminum beverage can to produce a slushed beverage. In certain embodiments, the methods can utilize the coated aluminum beverage cans described herein.

In some examples, the slushed beverage comprises at least one of soda, juice, milk, coffee, and tea. In other examples, the slushed beverage comprises at least one of beer, liquor,
 15 and wine. In certain examples, the slushed beverage comprises a sports drink or a nutritional supplement.

Aluminum Alloy Products

Described herein are aluminum alloy products and methods of preparing and using the
 20 aluminum alloy products. Products described herein include, for example, aluminum alloy cans and components for preparing the same, such as can body stock and can end stock.

Aluminum alloys for use in the products and methods described herein can include 3xxx series aluminum alloys and 5xxx series aluminum alloys. Suitable 3xxx series aluminum alloys include, for example, AA3002, AA3102, AA3003, AA3103, AA3103A, AA3103B, AA3203,
 25 AA3403, AA3004, AA3004A, AA3104, AA3204, AA3304, AA3005, AA3005A, AA3105, AA3105A, AA3105B, AA3007, AA3107, AA3207, AA3207A, AA3307, AA3009, AA3010, AA3110, AA3011, AA3012, AA3012A, AA3013, AA3014, AA3015, AA3016, AA3017, AA3019, AA3020, AA3021, AA3025, AA3026, AA3030, AA3130, and AA3065.

Suitable 5xxx series aluminum alloys include, for example, AA5005, AA5005A,
 30 AA5205, AA5305, AA5505, AA5605, AA5006, AA5106, AA5010, AA5110, AA5110A, AA5210, AA5310, AA5016, AA5017, AA5018, AA5018A, AA5019, AA5019A, AA5119,

AA5119A, AA5021, AA5022, AA5023, AA5024, AA5026, AA5027, AA5028, AA5040,
AA5140, AA5041, AA5042, AA5043, AA5049, AA5149, AA5249, AA5349, AA5449,
AA5449A, AA5050, AA5050A, AA5050C, AA5150, AA5051, AA5051A, AA5151, AA5251,
AA5251A, AA5351, AA5451, AA5052, AA5252, AA5352, AA5154, AA5154A, AA5154B,
5 AA5154C, AA5254, AA5354, AA5454, AA5554, AA5654, AA5654A, AA5754, AA5854,
AA5954, AA5056, AA5356, AA5356A, AA5456, AA5456A, AA5456B, AA5556, AA5556A,
AA5556B, AA5556C, AA5257, AA5457, AA5557, AA5657, AA5058, AA5059, AA5070,
AA5180, AA5180A, AA5082, AA5182, AA5083, AA5183, AA5183A, AA5283, AA5283A,
AA5283B, AA5383, AA5483, AA5086, AA5186, AA5087, AA5187, and AA5088.

10 Various products including the aluminum alloy products described herein can be
produced. The aluminum alloy products described herein can have any suitable gauge. In some
cases, the aluminum alloy may have a gauge from 180 to 300 μm . For example, the aluminum
alloy can have a gauge of about 180 μm , 185 μm , 190 μm , 195 μm , 200 μm , 205 μm , 210 μm ,
215 μm , 220 μm , 225 μm , 230 μm , 235 μm , 240 μm , 250 μm , 255 μm , 260 μm , 265 μm , 270
15 μm , 275 μm , 280 μm , 285 μm , 290 μm , 295 μm , or 300 μm .

Aluminum beverage cans can be produced by methods known in the art for aluminum
can manufacturing. In some examples, can bodies are produced from an aluminum sheet product.
The sheet, often in coil form, may be fed into a cupping press where disks are cut and formed
into cups. These steps are known as a blank and draw process. The cups are placed in a
20 bodymaker to undergo a draw and iron process to form the final shape of the can bodies. In some
cases, the bodymaker can use a moving ram to force the can body through a series of precision
rings to reduce the thickness of the metal and form the walls of the can body at a determined
height. A trimmer may remove excess material and ensure uniformity of the can opening. The
can bodies can be washed to remove lubricants that may be used during the forming process and
25 to prepare the can body surfaces for treatments such as coating, painting, or printing. In some
cases, the surface treatments may be decorative. In some cases, the surface treatments may
enhance the properties of the beverage can or reduce interactions from the eventual contents of
the can or the can end, which may be a different alloy than the can body.

Once the surface treatment is complete, the can bodies are fed to a necker/flanger process
30 that can shape the open end of the can body and optionally reduce the diameter of the open end

of the can body to shape the neck of the can body and produce a flange that can be mated and seamed with the can end after the can body is filled with the desired liquid.

In some examples, can ends may be produced from an alloy different than the can body. Can ends may be produced from an aluminum sheet product referred to as can end stock.

5 Optionally, the can end stock may include surface treatments such as coating, painting, or printing. The sheet, often in coil form, may be fed into a press to stamp and form the can end. The can end may pass through a series of presses to shape the can end, score the opening, and attach the tab. The can ends can be washed to remove lubricants that may be used during the forming process.

10 As shown in FIGS. 2A and 2B, a conventional aluminum beverage can 100 includes a can body 101 and a can end 103, where the can end 103 and can body 101 are connected to form a lip 107. The bottom of the can body 101 includes a dome 104 while the can end 103 comprises a tab 110 and scored opening 111. In certain examples, the bottom of the can body 101 may not include a dome. The bottom of the can body 101 may include other forms or shapes to achieve
15 stability and pressure control within the can. FIG. 3 shows a side profile of an aluminum beverage can according to one example described herein. The dome profile 604 determines the base diameter 605 of the aluminum beverage can. The finished can height 606 may be determined by the number of stages or rings used in the draw and iron process. The thickness of the sidewall of the aluminum beverage can may not be uniform. In some cases, the thinwall 603
20 may be thinner than the thickwall 602 near the neck 601 of the aluminum beverage can.

The can body 101 has an interior surface and an exterior surface, and the can end 103 also has an interior surface and an exterior surface. In some examples, the interior surface and/or exterior surface of the can body and/or can end may include an organic coating or a hydrophobic coating. In certain examples, the coating may comprise a conventional spray lacquer. Optionally,
25 the spray lacquer coating may be thicker or a double-coat compared to a conventional spray lacquer coating. The coating may alter the heat transfer properties of the aluminum beverage can. A first coating layer can contact the interior surface of the can body, while a second coating layer can contact the interior surface of the can end. FIG. 4 shows an aluminum beverage can 200 with a coating layer 202 on the interior surface of the sidewall 204 and an optional coating layer 206
30 on the exterior surface of the sidewall 204.

In some examples, the first and/or second coating layers comprise an organic coating that may include polyethylene terephthalate, polyamide, polypropylene, or polyolefin. In some cases, the first and/or second organic coating layers can be laminated to the interior surfaces of the can body and can end. Optionally, the can may further comprise an organic coating layer laminated to the exterior surface of the can body and/or can end. In certain examples, the coating may be a dispersion. In some examples, the thickness of the organic coating is about 2 μm to about 30 μm (e.g., about 6 μm to about 12 μm , about 10 μm to about 20 μm , or about 15 μm to about 30 μm). For example, the thickness can be about 2 μm , about 3 μm , about 4 μm , about 5 μm , about 6 μm , about 7 μm , about 8 μm , about 9 μm , about 10 μm , about 11 μm , about 12 μm , about 13 μm , about 14 μm , about 15 μm , about 16 μm , about 17 μm , about 18 μm , about 19 μm , about 20 μm , about 21 μm , about 22 μm , about 23 μm , about 24 μm , about 25 μm , about 26 μm , about 27 μm , about 28 μm , about 29 μm , or about 30 μm .

In some examples, the first and/or second coating layers comprise a hydrophobic coating. FIG. 5 shows the difference in droplet size (contact angle) in untreated aluminum compared to superhydrophobic aluminum treated according the methods described herein. In certain cases, superhydrophobic aluminum is an aluminum alloy product that has been treated with a hydrophobic coating. In some examples, a hydrophobic coating can increase the contact angle of the beverage and the aluminum beverage can wall. As shown in FIG. 5, the amount of fluid and size of droplets 304 on the untreated aluminum is much greater than that of the superhydrophobic aluminum where droplets 303 are much smaller and less numerous. In some examples, a hydrophobic coating can increase the contact angle of the beverage and the aluminum beverage can wall by at least 50°. In other examples, the hydrophobic coating can increase the contact angle of the beverage and the aluminum beverage can wall by at least 80°. For example, the contact angle can increase by 50°, 51°, 52°, 53°, 54°, 55°, 56°, 57°, 58°, 59°, 60°, 61°, 62°, 63°, 64°, 65°, 66°, 67°, 68°, 69°, 70°, 71°, 72°, 73°, 74°, 75°, 76°, 77°, 78°, 79°, 80°, 81°, 82°, 83°, 84°, 85°, 86°, 87°, 88°, 89°, 90°, or greater than 90°. In some examples, the hydrophobic coating can comprise a fatty acid, for example, lauric acid. In some examples, the aluminum beverage can may be etched using a base, for example, potassium hydroxide (KOH), and coated with the fatty acid.

In some examples, an aluminum beverage can for making a slushed beverage comprises a nucleation device in addition to or instead of the coating layer described above. In certain

examples, the nucleation device may include gas and/or nucleation particles. The nucleation device may be attached to the dome on the interior of the can body and be configured to release the gas and/or nucleation particles into the beverage housed in the aluminum beverage can upon opening the aluminum can. FIGS. 6A and 6B show a can 400 with a nucleation device 405 in the dome. In some cases, the nucleation device can be a widget, as known by one skilled in the art, that is utilized in other fields of endeavor to improve the characteristics of certain beers. As shown in FIG. 6A, the nucleation device 405 may release fine gas bubbles 406 into the chilled beverage 400 upon opening and provide nucleation sites for ice crystal formation. In some cases, the gas within the nucleation device can comprise nitrogen or carbon dioxide. In other cases, the gas within the nucleation device can comprise an inert gas. In some examples, the pressure within the nucleation device is greater than 20 psi. In certain examples, the pressure within the nucleation device can be up to 50 psi. The nucleation device can release microbubbles, as nucleation sites within the beverage.

Optionally, as shown in FIG. 6B, the nucleation device 405 may comprise nucleation particles 407 upon opening and provide nucleation sites to generate ice crystals. Nucleation particles may also be introduced from an external implement into the beverage upon opening the aluminum beverage can. In some cases, the particles may be introduced into the beverage by inserting into the beverage a straw or stick coated with nucleation particles. In some cases, the particles can comprise at least one of sugar, acesulfame K, advantame, aspartame, neotame, saccharin, stevia, sucralose, and other sugar substitutes. In some cases, the particles may have a length of about 1 mm to about 5 mm. In some cases, the particles can be in a dried form. For example, the particles can have a water content less than 1 weight percent (e.g., less than 0.5 weight percent, less than 0.1 weight percent, or less than 0.05 weight percent). For example, the water content of the particles may be less than 1 weight percent, less than 0.8 weight percent, less than 0.6 weight percent, less than 0.4 weight percent, less than 0.2 weight percent, less than 0.1 weight percent, less than 0.08 weight percent, less than 0.06 weight percent, less than 0.05 weight percent, less than 0.04 weight percent, less than 0.03 weight percent, less than 0.02 weight percent, or less than 0.01 weight percent. In some examples, the particles can be crystalline in nature and provide for rapid crystal growth.

30

Methods of Making Slushed Beverages

The aluminum alloy products and methods described herein can be used for making slushed beverages in aluminum cans. As previously described and shown in FIG. 1, chilled beverages may freeze along the aluminum beverage can wall when chilled, which may partially solidify the beverage and prevent nucleation needed for the desired slushed beverage. Some methods described herein rotate or vibrate the aluminum beverage can while chilling the aluminum beverage can to or below the freezing temperature of the beverage to equalize the temperature gradient within the aluminum beverage can and disturb the fluid to aid in uniform chilling of the beverage. As shown in FIG. 7, disturbing the beverage while chilling may reduce the boundary layer and substantially prevent the beverage from forming a frozen layer at the sidewall. As compared to FIG. 1, the boundary layer of the disturbed beverage is smaller and the temperature profile is flatter, which aid in preventing the beverage from freezing on the sidewall of the aluminum beverage can. Some considerations for making slushed beverages are the orientation of the aluminum beverage can during rotation and the orientation of the aluminum beverage can relative to a vibration. The method may involve adjusting the orientation of the can during rotation and/or the orientation of the can relative to the vibration, and/or surface characteristics of the beverage can. In some examples, an apparatus or system may be used to rotate and/or chill the aluminum beverage can to generate the slushed beverage within the aluminum beverage can.

In some examples, an aluminum beverage can may be oriented at an angle ranging from 30° to 90° from vertical and rotated for a first rotation period about the longitudinal axis. FIG. 8 shows the longitudinal axis, the center of rotation, of a beverage can. Optionally, the beverage can may be placed in a designed holder to orient and rotate the can during the cooling step. FIG. 9 shows one example of a holder 500 that may be used to grasp the can during rotation. In some examples, the holder may comprise fingers 501 or other projections to grasp the aluminum beverage can from a tabbed end or a domed end of the aluminum beverage can. In some cases, the aluminum beverage can may be rotated at a rate of about 1000 rpm to about 1500 rpm. In other examples, the aluminum beverage can may be oriented approximately 45° from vertical and rotated about the longitudinal axis at a rate of about 1000 rpm to about 1500 rpm. FIGS. 10A, 10B, and 10C show a beverage can placed in a holder attached to a rotating arm, where the can is oriented at 0°, 45°, and 90°, respectively.

Optionally, the rotation of the aluminum beverage can further comprises movement in a conical pattern or wobble to further mix the beverage and disturb the boundary layer at the sidewall. As shown in FIG. 11, the conical movement may be such that the movement of a distal end of the can (R2) is greater than the movement of a proximal end of the can (R1) as measured substantially perpendicular to the longitudinal axis of rotation.

In some cases, the method comprises cooling the aluminum beverage can in a coolant bath from about -20 °C to about -40 °C for about 20-120 seconds (e.g., -23 °C to -30 °C or -25 °C to -28 °C). Any suitable solution or mixture can be used to form the coolant bath. In certain examples, a liquid bath comprising a heat transfer fluid, as described above, can be used to cool the aluminum beverage can. For example, liquid nitrogen or carbon dioxide can be used to cool the aluminum beverage can.

Optionally, the method may comprise further rotating the aluminum beverage can for an additional rotation period, such as a second rotation period, where the aluminum beverage can orientation may be different from that of the first rotation period. The method can further comprise rotating the can within an ultrasonicator. For example, the method can include rotating the aluminum beverage can as described above at 45° for a first rotation period and transferring the aluminum beverage can to an ultrasonicator where the aluminum beverage can is rotated in a horizontal direction (90°) for a second rotation period. By rotating the can in a horizontal or substantially horizontal orientation and subjecting the aluminum beverage can to ultrasonic vibration, freezing of the liquid contents of the aluminum beverage can on the wall of the aluminum beverage can or bottom of the aluminum beverage can may be avoided as nucleation begins. The aluminum beverage can may be considered oriented in a substantially horizontal position when the longitudinal axis of the aluminum beverage can is +/- 10° or less from horizontal (e.g., +/- 5° or less or +/- 2° or less). In some examples, the ultrasonicator bath temperature can be from about 4 °C to about 10 °C.

The rotation time of the aluminum beverage can may differ based on the viscosity or salinity of the contents. In some examples, the rotation time can be from about 10 seconds to about 120 seconds in the first bath for the first rotation period at the first orientation and can be from about 5 seconds and about 60 seconds for the second rotation period in the ultrasonicator at the second rotational orientation.

Optionally, the method may comprise placing the aluminum beverage can in a polymer sleeve prior to rotating the aluminum beverage can within the coolant bath for the first rotation period or rotating in the ultrasonicator for the second rotation period. The polymer sleeve can modify the heat transfer rate between the coolant bath and the aluminum beverage can to

5 substantially prevent formation of an ice layer at the interior wall of the aluminum beverage can. The formation of ice layer may be substantially prevented when the ice layer is less than 2 mm thick at the boundary layer (e.g., less than 1.5 mm or less than 1 mm), or when ice crystals fail to form a boundary layer at the interior wall.

In addition to or instead of the rotating the aluminum beverage can as described above,

10 the method may comprise rotating one or more magnets (e.g., diamagnetic magnets) adjacent to the rotating aluminum can, where the rotational direction of the magnets can be the same as the beverage can. FIG. 12 shows a rotating magnet adjacent to the aluminum can. In some cases, the one or more magnets can be a rare earth magnet. For example, the magnets can include neodymium (Nd) and iron (Fe), such as a NdFeB magnet. In some cases, the alternating

15 magnetic field generated by rotating magnets can locally heat the walls of the aluminum beverage can through induction heating and substantially prevent formation of an ice layer at the interior wall of the aluminum can. In some cases, the aluminum beverage can may be orientated in any direction, including vertical (0°) and the induction heating from the rotating magnets can sufficiently heat the sidewalls of the can to prevent the beverage from solidifying and/or prevent

20 ice formation at the sidewall.

Optionally, in addition to or instead of rotating the aluminum beverage can as described above, the method can comprise vibrating the can while chilling to generate resonant modes within the can and break ice as it forms or prevent it from forming on the sidewalls. In some cases, the vibration also nucleates the beverage to form the ice crystals. FIG. 13 shows one

25 example of vibrating the aluminum beverage can using a piezoelectric motor/actuator at the base of the can, but the aluminum beverage can may be vibrated using other suitable ways.

FIG. 14 shows the expected nucleation from 20 kHz in an aluminum beverage can as compared to a PET bottle. Not only does the aluminum beverage can produce less damping of acoustical energy, it also has a higher heat transfer coefficient and heat conductivity than PET,

30 which can also lead to increased ice formation. Increased nucleation can lead to a finer ice crystal or grain for the slushed beverage and increased foaming, which is undesirable. An

acoustical vibration of equal strength may resonate throughout an aluminum beverage can due to the lower damping effect of an aluminum beverage can as compared to a PET bottle. The same acoustical vibration applied to a can and PET bottle may only impact the bottom zone of the PET bottle due to the damping effect of the PET bottle and cause localized nucleation. In some cases, the rate and degree of nucleation can be modified by altering the placement of the vibration source relative to the aluminum beverage can.

In some examples, the oscillation frequency can be tuned to an eigenmode of the liquid beverage to generate maximum wall motion and flexion. This motion can dislodge ice that may have formed at the sidewalls and allow for additional cooling or the production of seed crystals which can remain suspended in the liquid for slushy production.

FIG. 15 shows a side view of an alternate orientation for vibrating an aluminum beverage can to induce the desired amount of nucleation, where the aluminum beverage can is inverted with the can end in contact with the vibrational source. FIG. 16 is a bottom view of an alternate orientation that shows the placement of the acoustical energy on the can end of the inverted aluminum can. By inverting the can, the thicker gauge can end and tab can aid to dampen the energy wave by absorbing more energy than the dome and can wall in an upright orientation. The inversion also starts nucleation at the “bottom” of the can, which will travel through the entire beverage upon inversion prior to opening. In other cases, the acoustical energy can be applied to the side of the can. In some examples, the acoustical energy applied can be about 20 kHz to about 40 kHz.

The surface of the aluminum beverage can may also impact the degree of nucleation within a beverage. An aluminum beverage can may have a rougher surface than a PET bottle. As shown in FIGS. 17 and 18, the surface of an aluminum beverage can (FIG. 17) may be more variable across the sample width as compared to a conventional PET bottle (FIG. 18). The amount of energy required for heterogeneous nucleation is lower on rough surfaces as compared to smooth surfaces, which can cause ice buildup on the surface of the can, especially the sidewall.

The surface of the aluminum beverage can may be modified to enhance the texture of the aluminum beverage can to impart properties for making slushed beverages. In some cases, one or more surfaces of the aluminum beverage can may be modified to impart hydrophobic or non-wetting properties or coating. For example, hydrophobic properties may be imparted to the

surface of the aluminum beverage can using a solution-phase approach, chemical etching, sol-gel process, vapor deposition, anodic oxidation, electrochemical etching, slippery liquid-infused porous surfaces (SLIPS), non-stick coatings, such as a non-stick coating in the LiquiGlide® line, commercially available from LiquiGlide, Inc. (Cambridge, Massachusetts), or other methods
5 known to those skilled in the art. In some cases, the coating may be a superhydrophobic coating that is nanoscopic. The thickness of the hydrophobic coating may be less than 500 nm in size (e.g., less than 100 nm or less than 25 nm). In some cases, the thickness may be less than 1 nm, less than 5 nm, less than 10 nm, less than 25 nm, less than 50 nm, less than 75 nm, less than 100 nm, less than 150 nm, less than 200 nm, less than 250 nm, less than 300 nm, less than 350 nm,
10 less than 400 nm, less than 450 nm, or less than 500 nm in size. In some examples, the thickness of the hydrophobic coating may not be uniform across the surface of the aluminum beverage can.

In some examples, the surface of the aluminum beverage can may be etched with a base solution and coated with a fatty acid. In some cases, the aluminum beverage can may be etched with KOH. In some cases, the fatty acid may include lauric acid. In some examples, the
15 hydrophobic treatment can increase the contact angle of the beverage and the aluminum beverage can wall.

Also described herein is a method of imparting a hydrophobic or non-wetting property to an aluminum product, such as an aluminum beverage can body or can end. The method can include an optional step of heating the aluminum beverage can body and/or can end to a
20 temperature ranging from 55 °C to 80 °C, followed by etching one or more surfaces of the aluminum beverage can body and/or can end, contacting one or more surfaces of the aluminum beverage can body and/or can end with a substance that imparts hydrophobic or non-wetting properties, and then drying the one or more surfaces of the aluminum beverage can body and/or can end. Alternatively, the etching and contacting steps listed above can be performed in one
25 step. For example, the method can include an optional step of heating the aluminum beverage can body or can end to a temperature ranging from 55 °C to 80 °C, contacting one or more surfaces of the aluminum beverage can body or can end with a mixture containing an etchant and a substance that imparts hydrophobic or non-wetting properties, and then drying the one or more surfaces of the aluminum beverage can body or can end.

30 In some examples, the immersion time of the aluminum beverage can body or can end in the etchant can be about 5 to about 60 minutes (e.g., about 5 minutes to about 30 minutes or

about 10 minutes to about 40 minutes). In some examples, the immersion time of the aluminum beverage can body or can end in the fatty acid can be about 5 to about 30 minutes (e.g., about 5 minutes to about 15 minutes or about 10 minutes to about 20 minutes). In other examples, the immersion time of the aluminum beverage can body or can end in the solution comprising the etchant and the fatty acid can be about 5 to about 30 minutes (e.g., about 5 minutes to about 15 minutes or about 10 minutes to about 20 minutes).

As shown in FIG. 19, the step of contacting one or more surfaces of the aluminum beverage can body and/or can end with a substance that imparts hydrophobic or non-wetting properties may include immersing the aluminum beverage can body or end in a solution of potassium hydroxide (KOH) and a solution comprising a fatty acid. The KOH can etch or roughen the surface of aluminum. In some cases, the fatty acid can be lauric acid (C₁₂H₂₄O₂). In some examples, the method can comprise immersing the aluminum beverage can body and/or can end in a KOH solution, rinsing the aluminum beverage can body and/or can end with deionized water, and immersing the aluminum beverage can body and/or can end in a fatty acid solution. Optionally, the method can comprise drying the aluminum beverage can body and/or can end after the fatty acid immersion. In other examples, the method can comprise immersing the aluminum beverage can body and/or can end in a solution comprising KOH and a fatty acid. In some examples, the immersion time of the aluminum beverage can body and/or can end in KOH can be about 5 to about 60 minutes. In some examples, the immersion time of the aluminum beverage can body and/or can end in the fatty acid can be about 5 to about 30 minutes. In other examples, the immersion time of the aluminum beverage can body and/or can end in the solution comprising KOH and the fatty acid can be about 5 to about 30 minutes. The reaction of the KOH and lauric acid with aluminum is shown in the equations below.

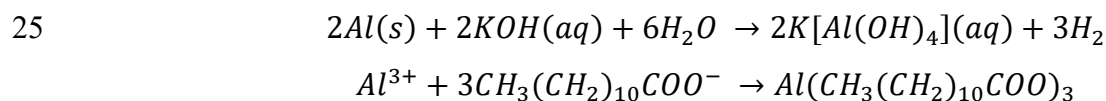

In some examples, a hydrophobic coating can increase the contact angle of the beverage and the aluminum beverage can wall by at least 50°. In other examples, the hydrophobic coating can increase the contact angle of the beverage and the aluminum beverage can wall by at least

80°. The coating can change the heat transfer coefficient and alter the freezing point of the beverage at the sidewall due to the lower level of condensation shown in FIG. 5.

Examples

5 Samples of aluminum alloy were processed according the process steps shown in FIG. 19. Six measurements were made at various time points of the two-step process to determine the resulting contact angle for each time point. Two measurements were made at various time points of the one-step process to determine the resulting contact angle for each time point. FIG. 20 shows the increased contact angle of the treated aluminum based on treatment time and treatment process (one-step or two-step). The two-step process achieved an increase in as little as 5 10 minutes of total immersion. The one-step process achieved substantially similar contact angle results (increase from 70.6° to 152°) as the two-step process after 60 minutes total immersion time.

15 Samples of aluminum alloy that were etched and coated were soaked in a 3% sodium chloride (NaCl) bath and measured at various time points to determine the resulting contact angle at each time point. As FIG. 21 shows, the hydrophobic coating was unchanged over a 24-hour period and only decreased 7° (152° to 145°) over a 10-day period when immersed in a 3% NaCl solution.

20 Additional tests revealed the coating was resistant up to 150 °C annealing and remained substantially unchanged after UV exposure and after 90° and 180° bending.

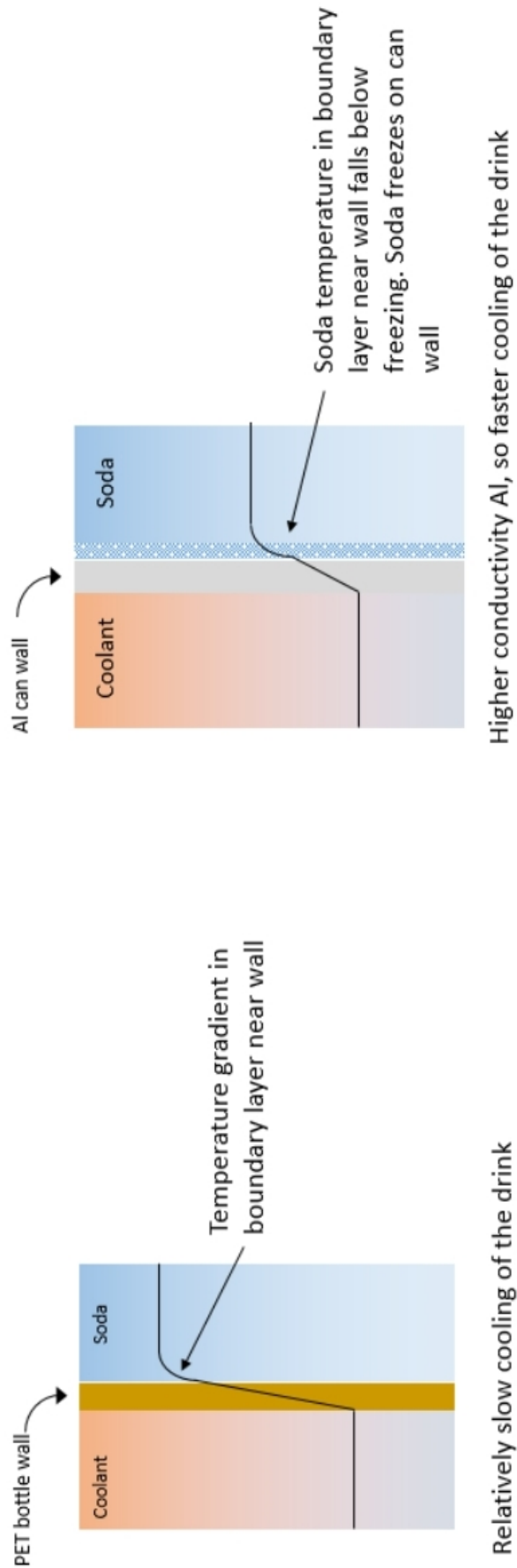

FIG. 1

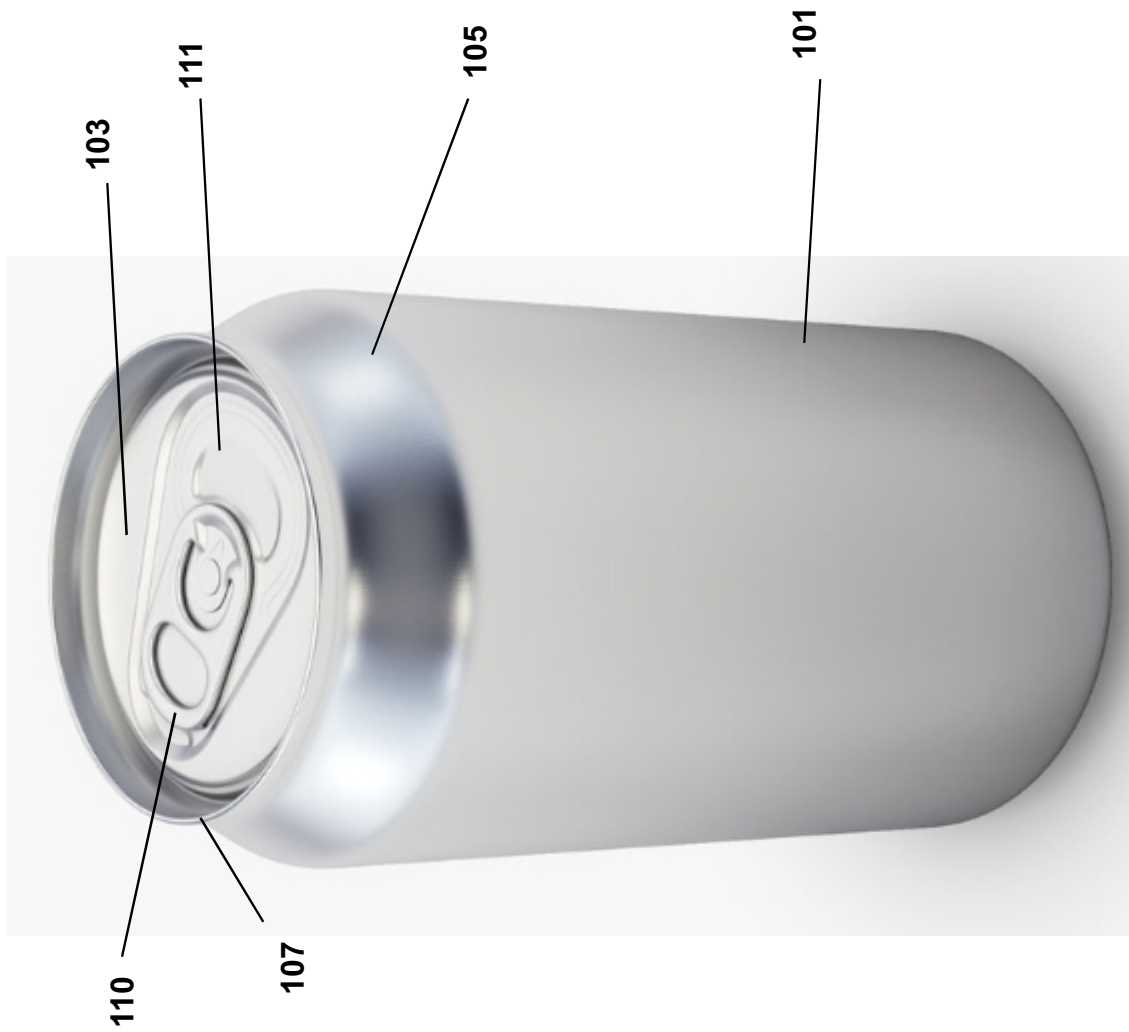

FIG. 2A



FIG. 2B

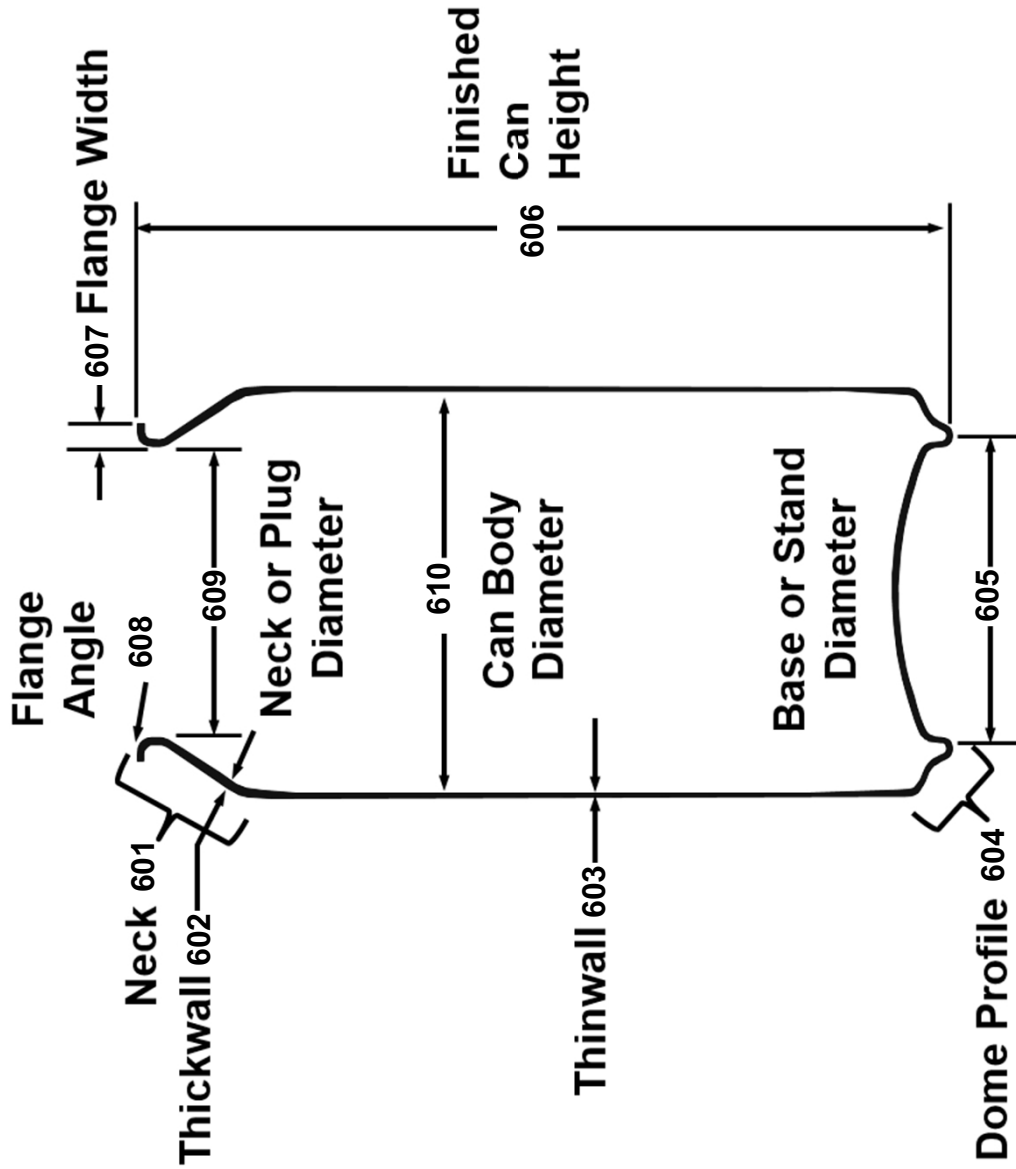

FIG. 3

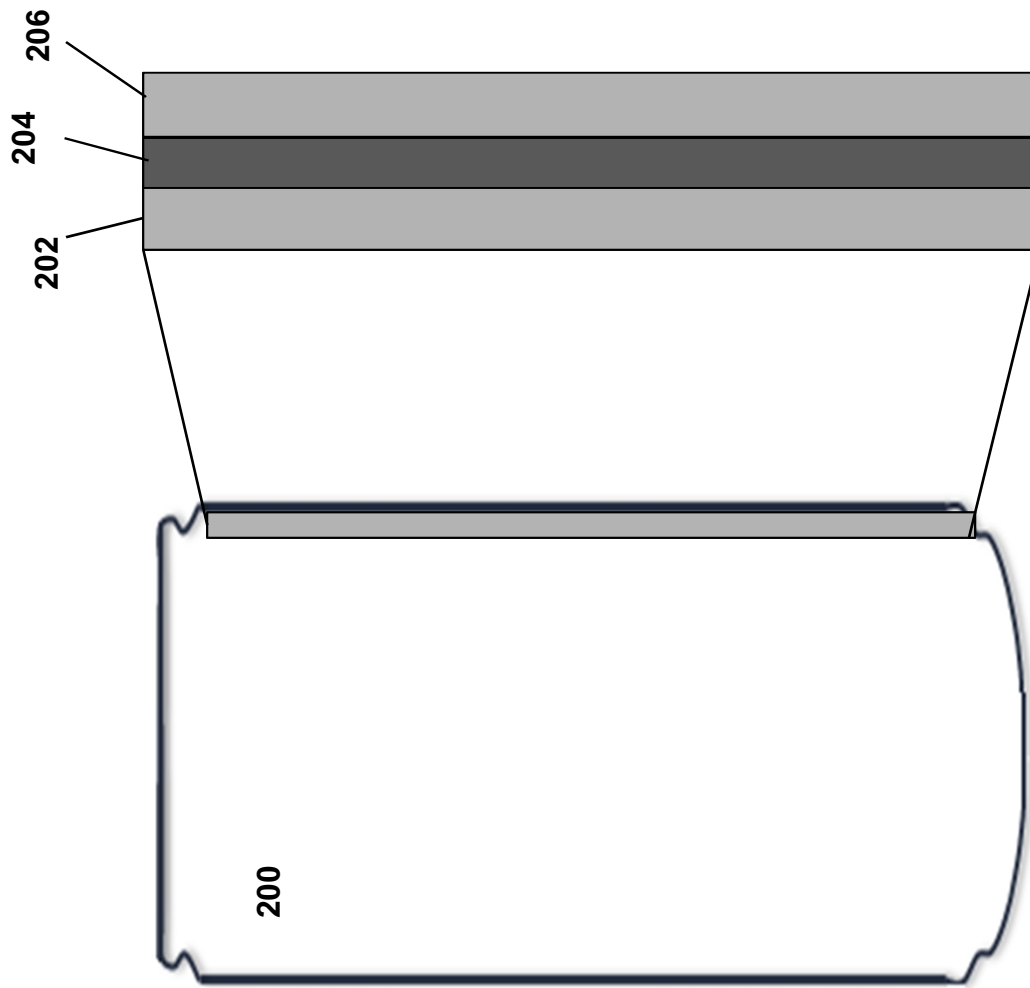

FIG. 4

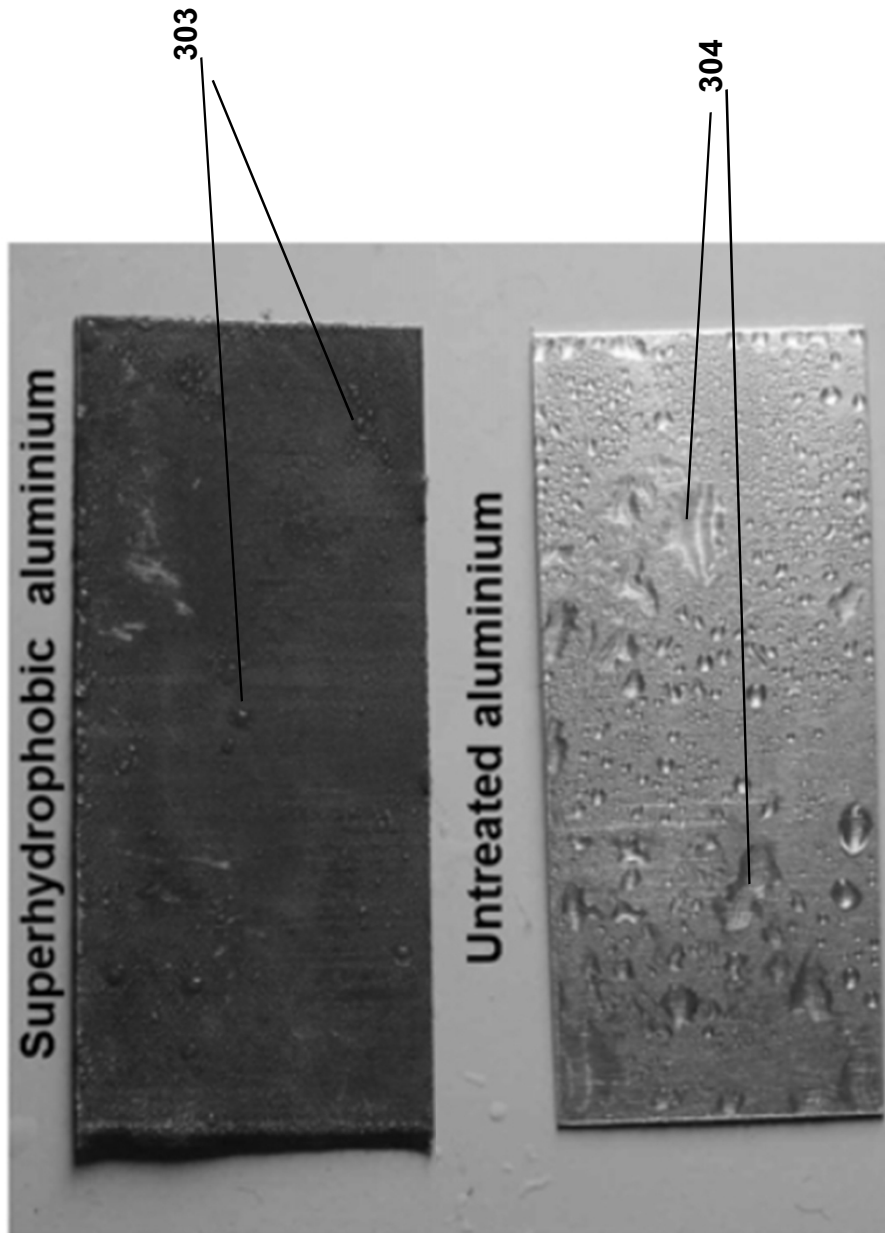

FIG. 5

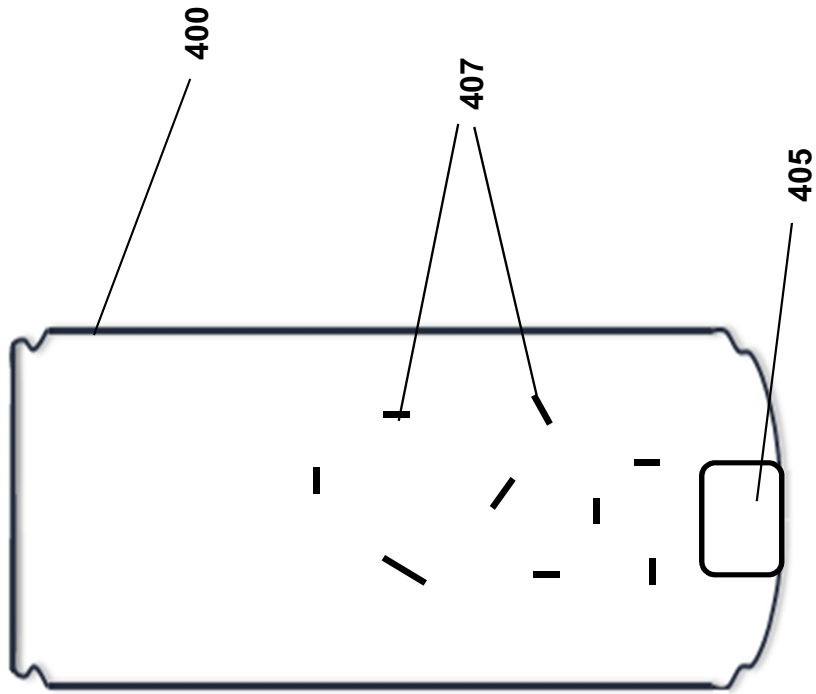

FIG. 6B

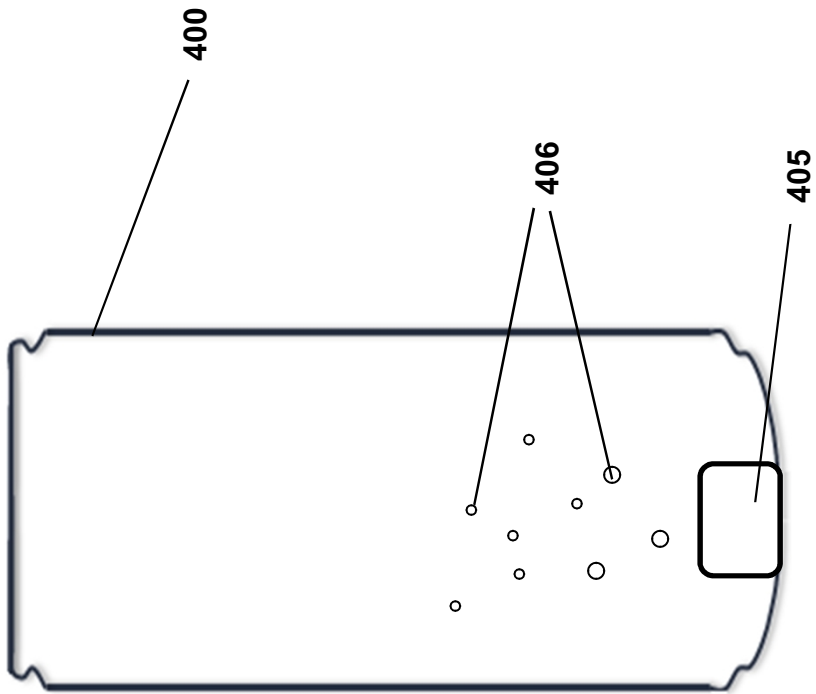

FIG. 6A

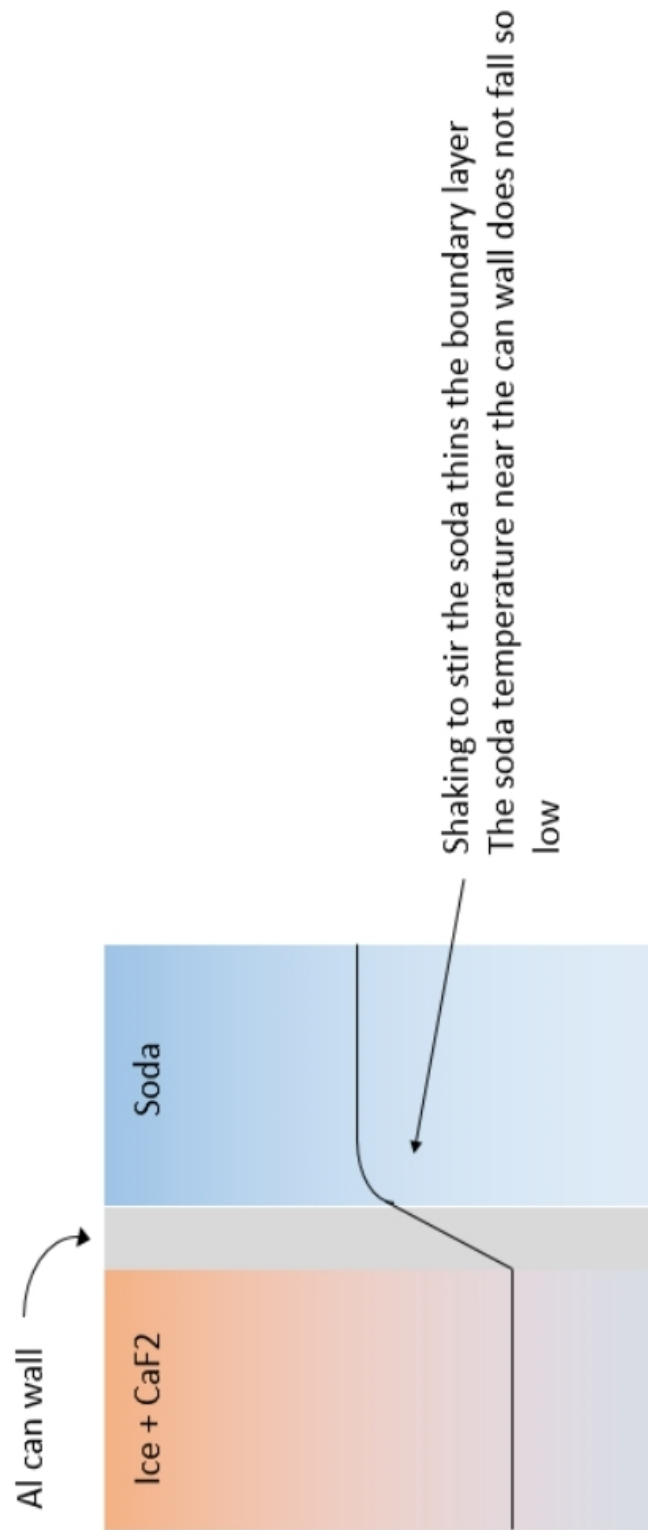

FIG. 7



FIG. 8

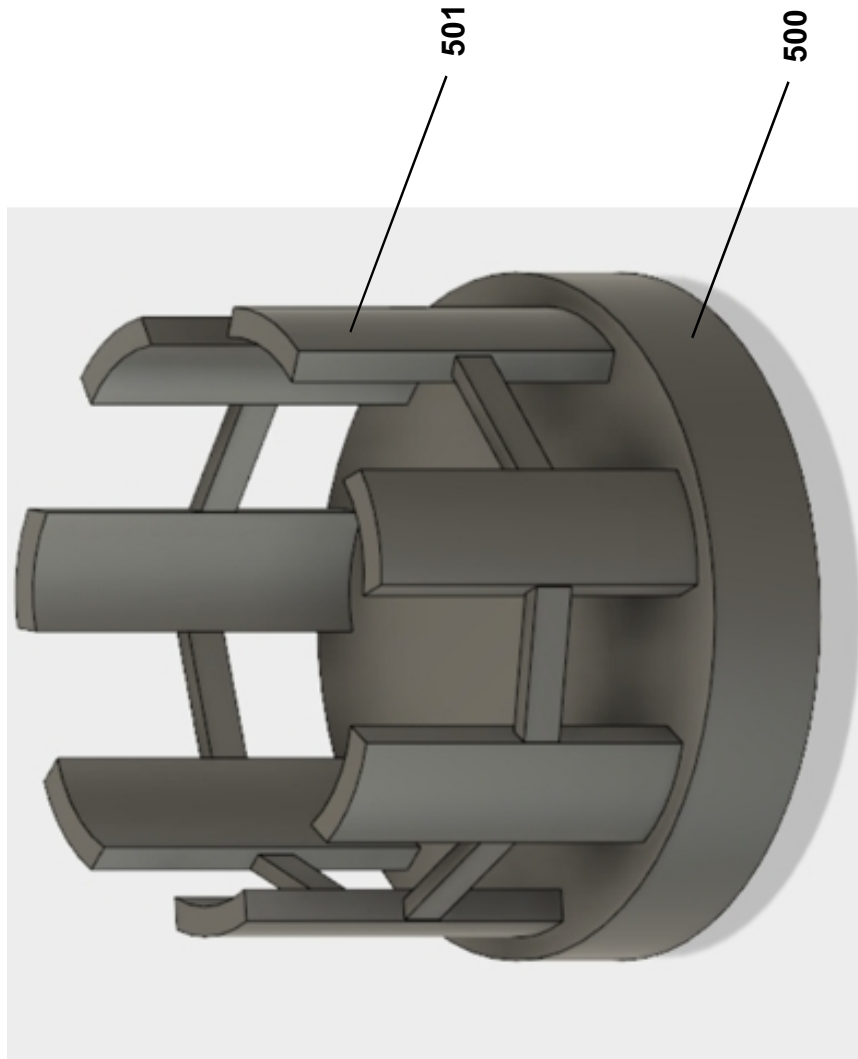

FIG. 9

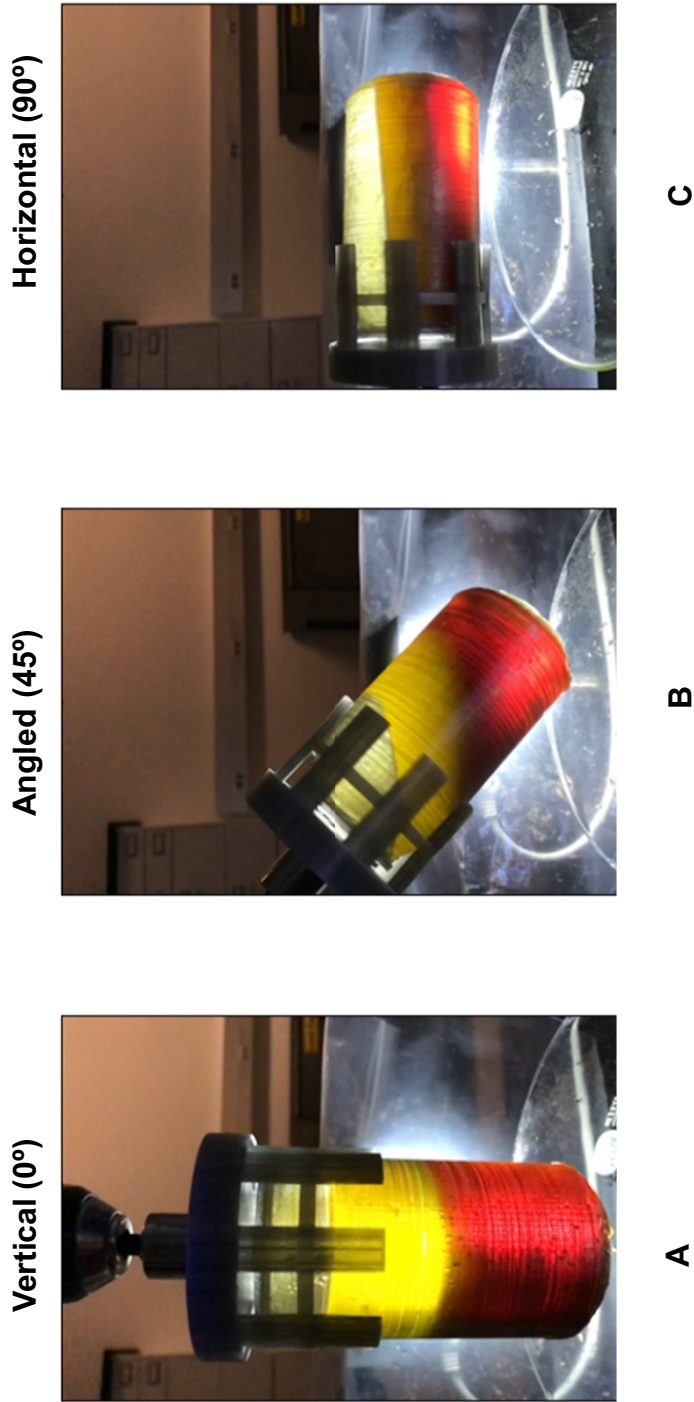

FIG. 10

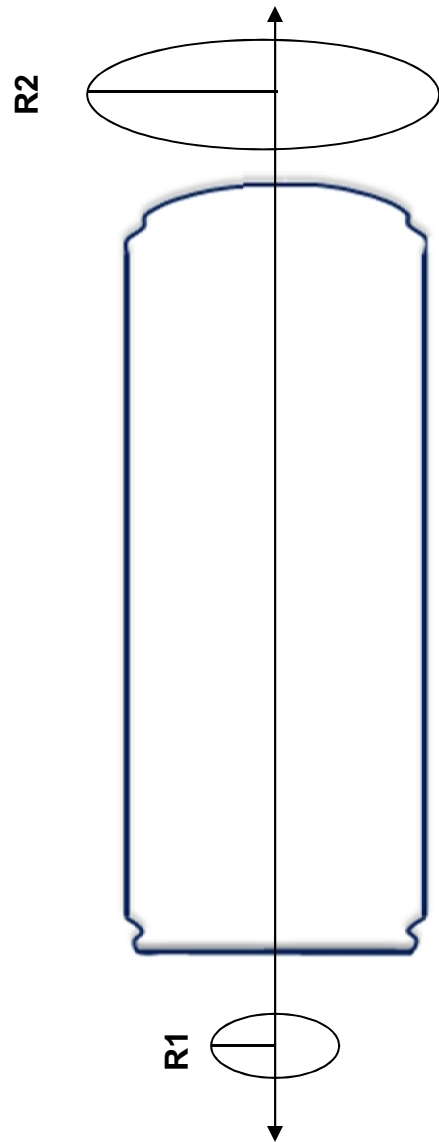

FIG. 11



Diamagnetic NdFe
magnet rotating in
same direction as can

FIG. 12

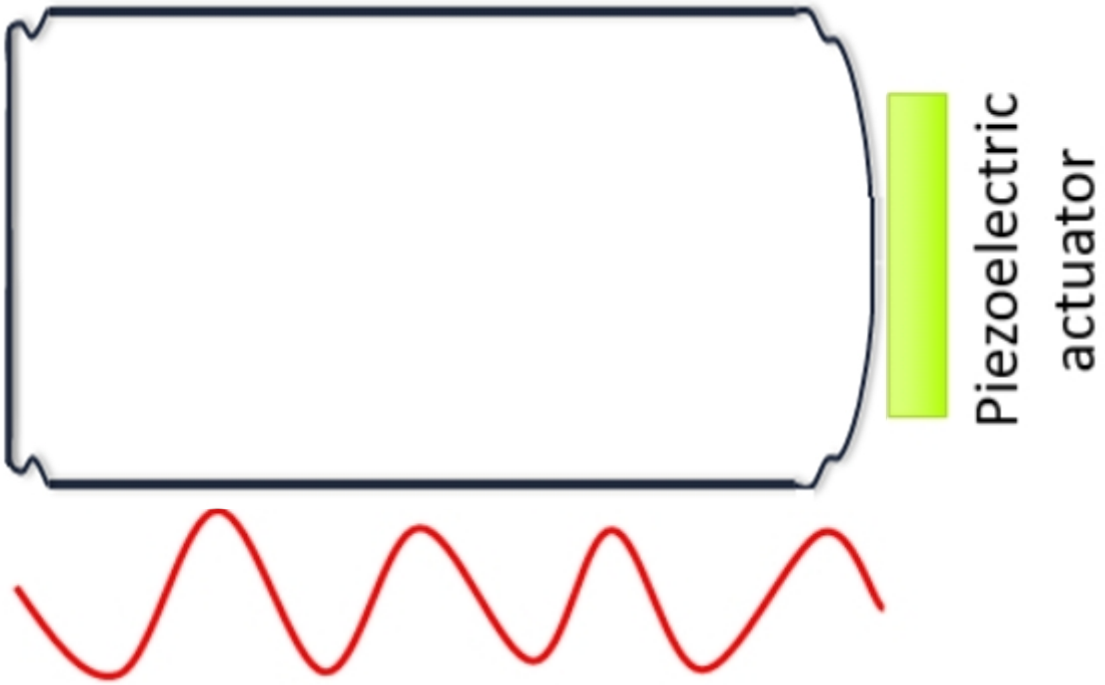

FIG. 13

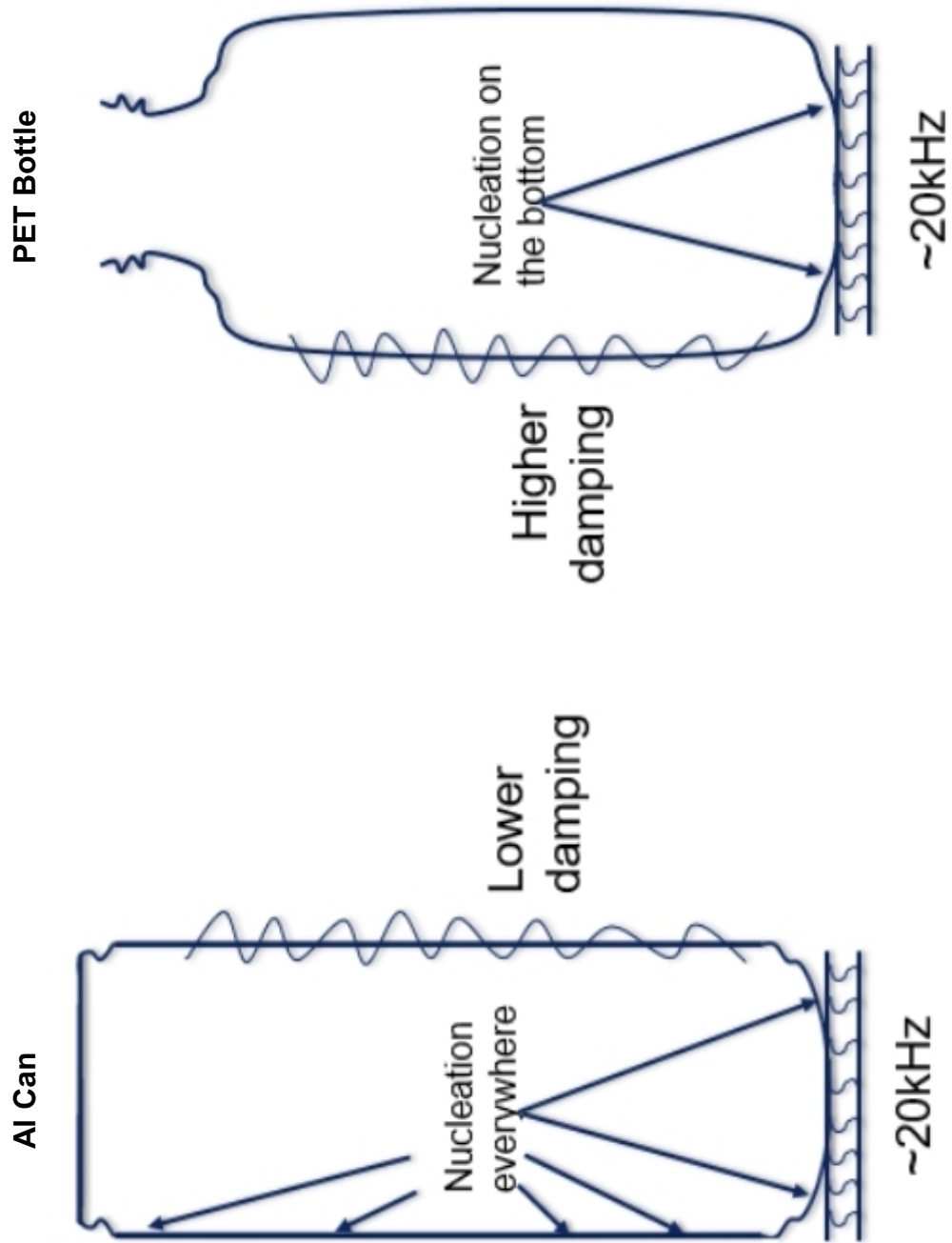

FIG. 14



FIG. 16

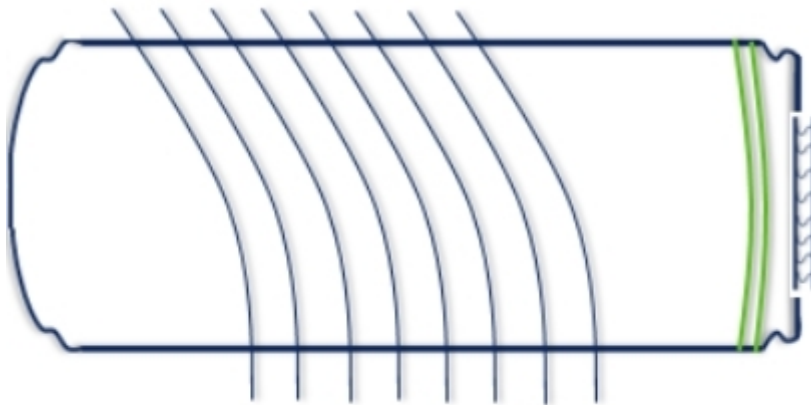

FIG. 15

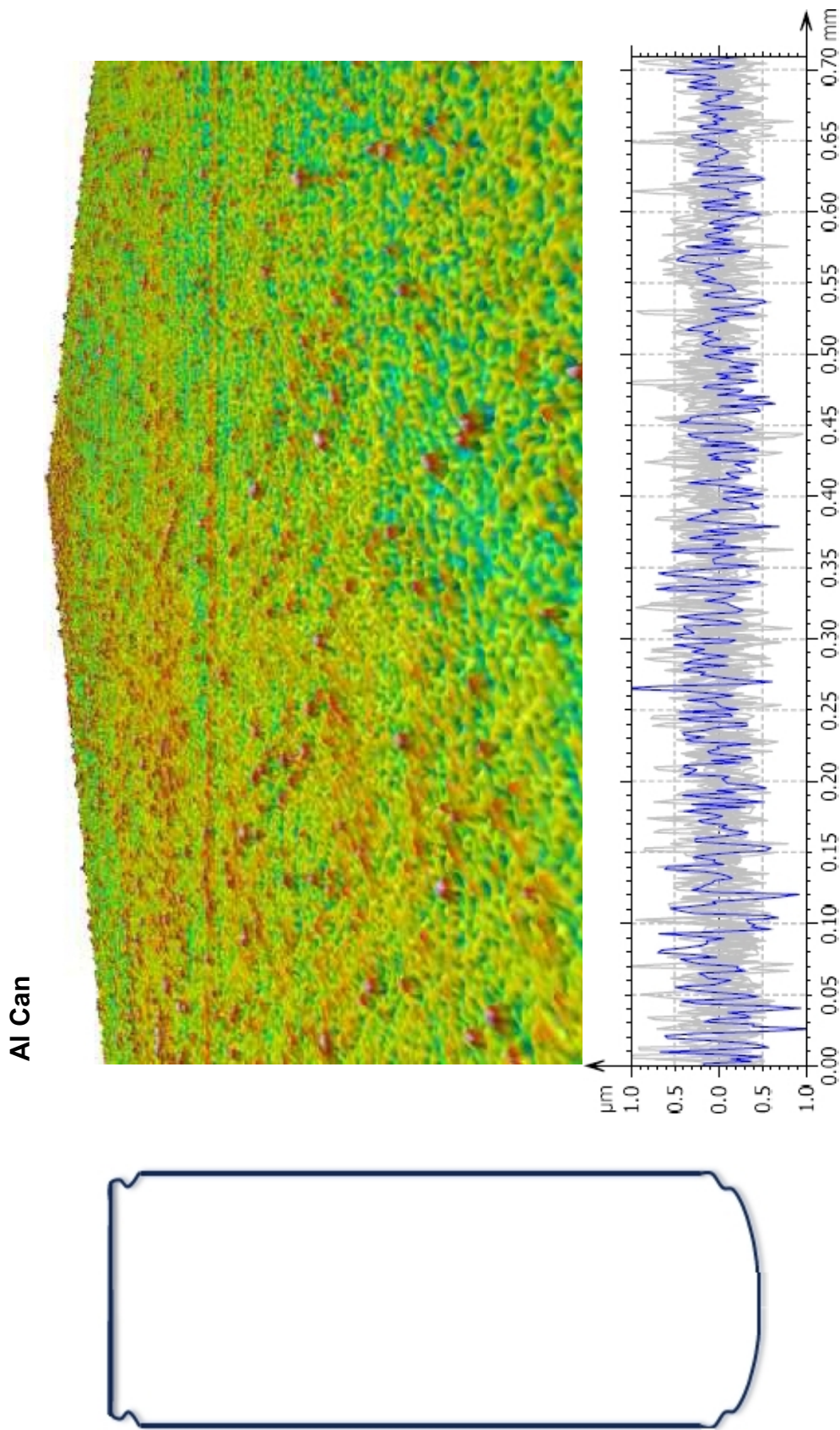

FIG. 17

PET bottle

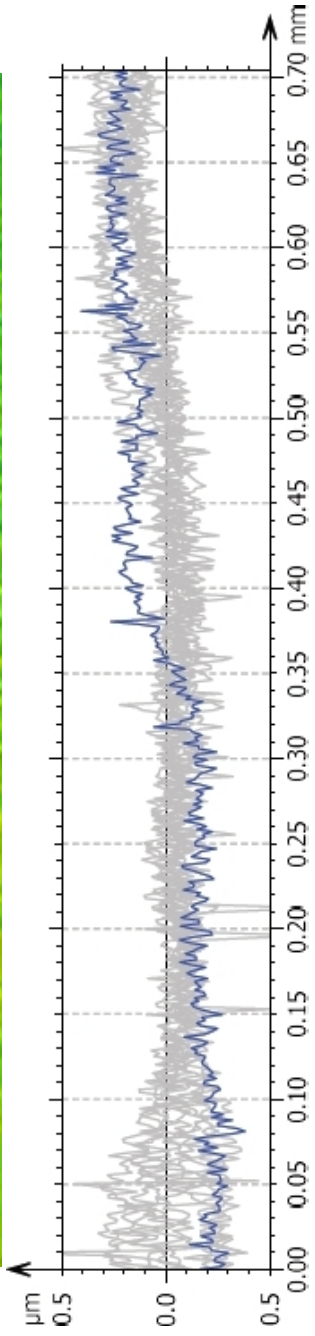
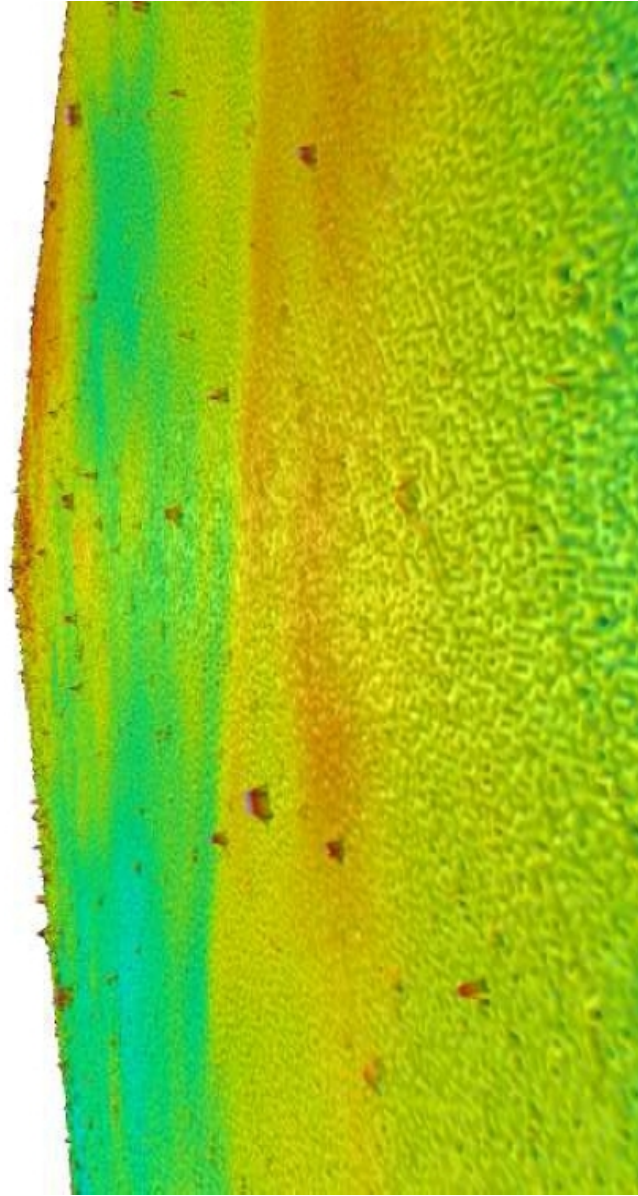
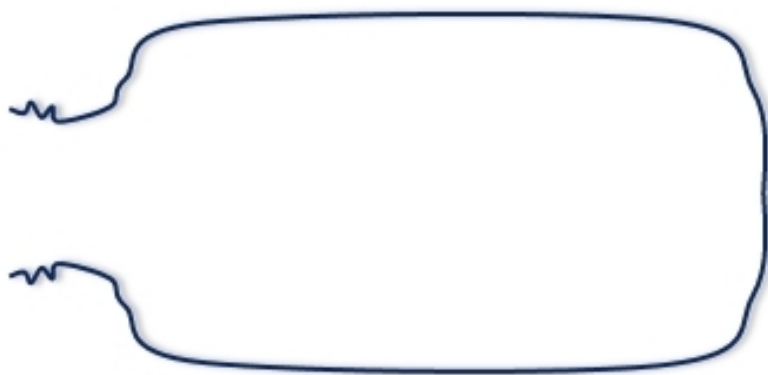

FIG. 18

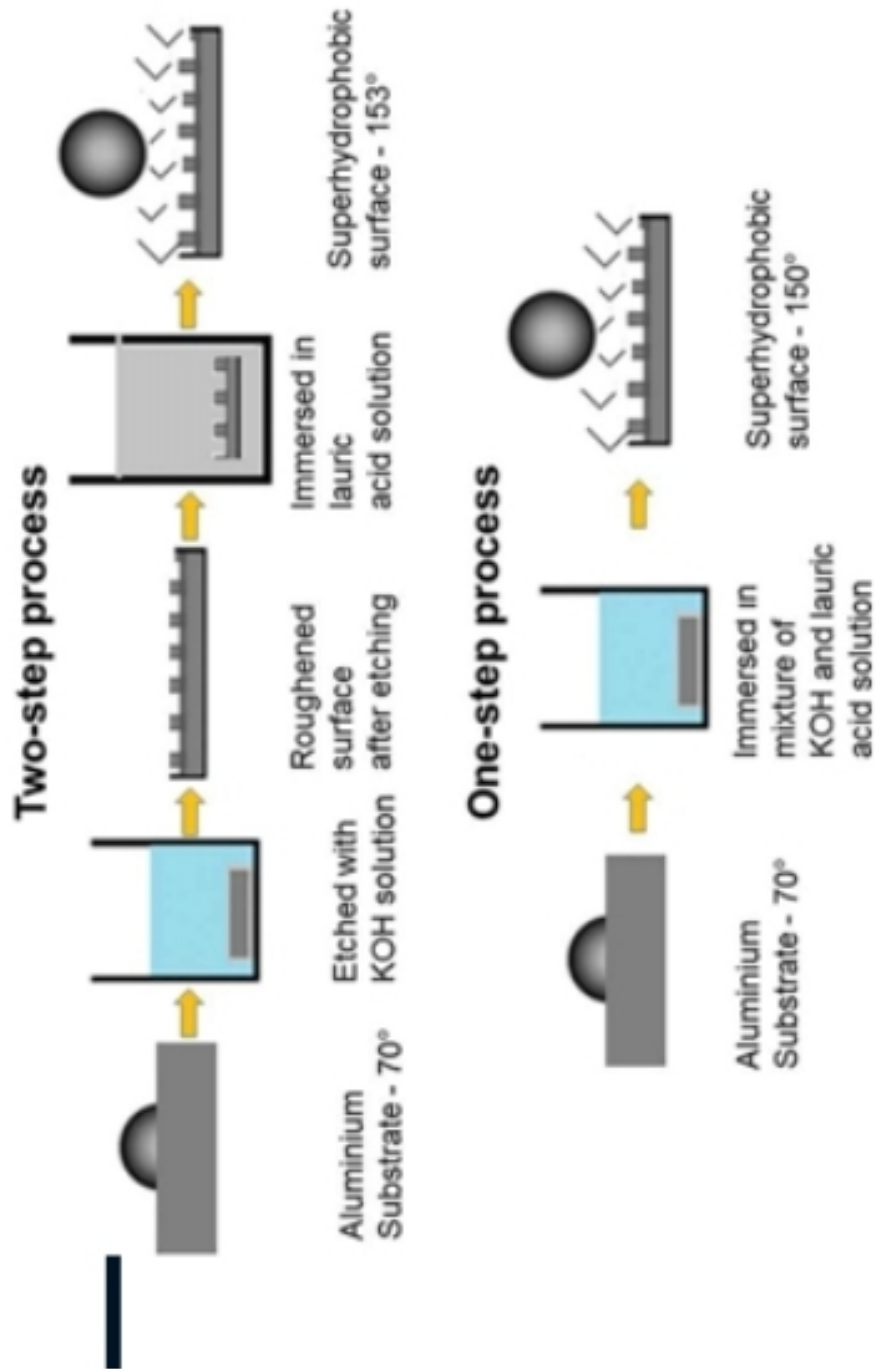

FIG. 19

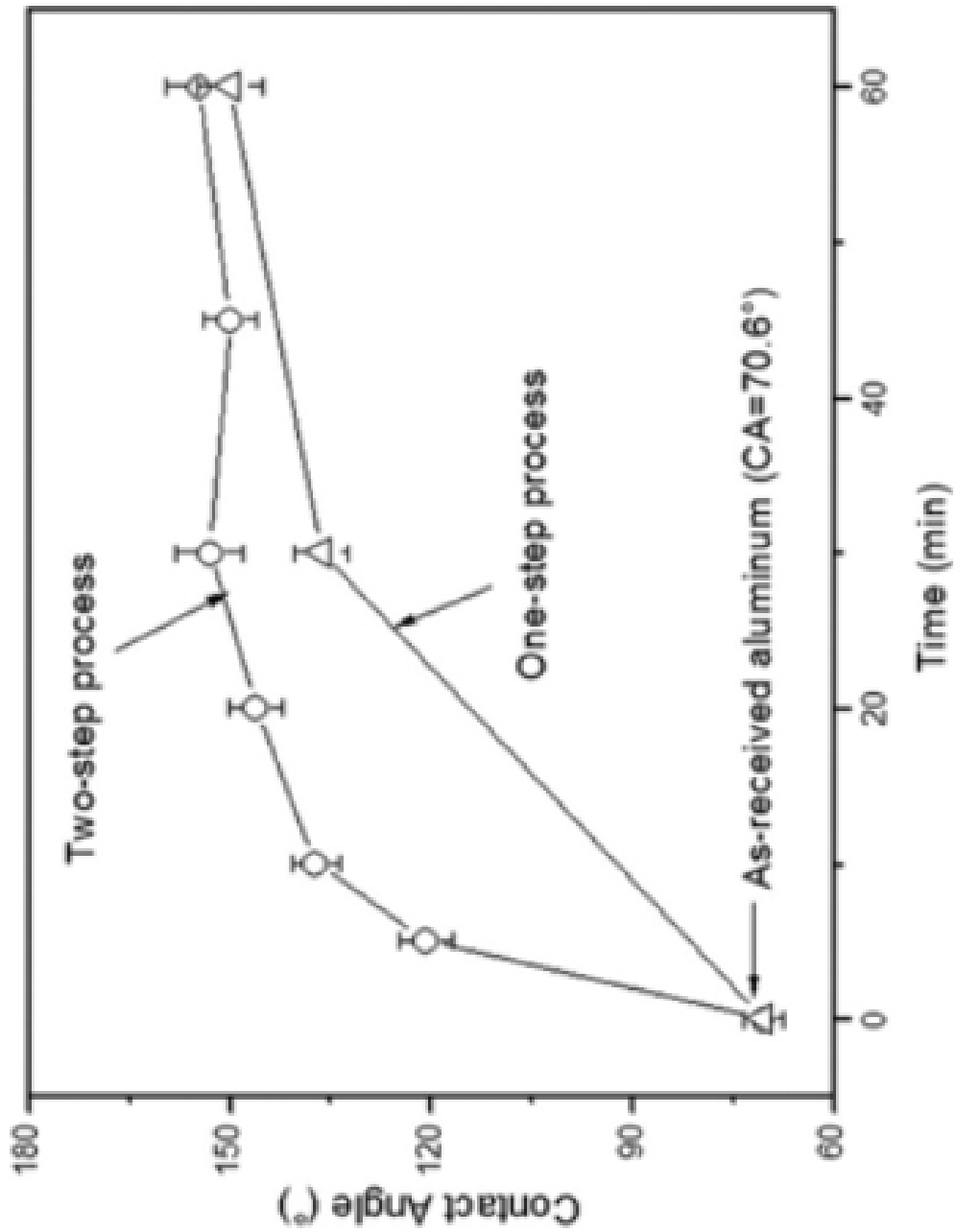

FIG. 20

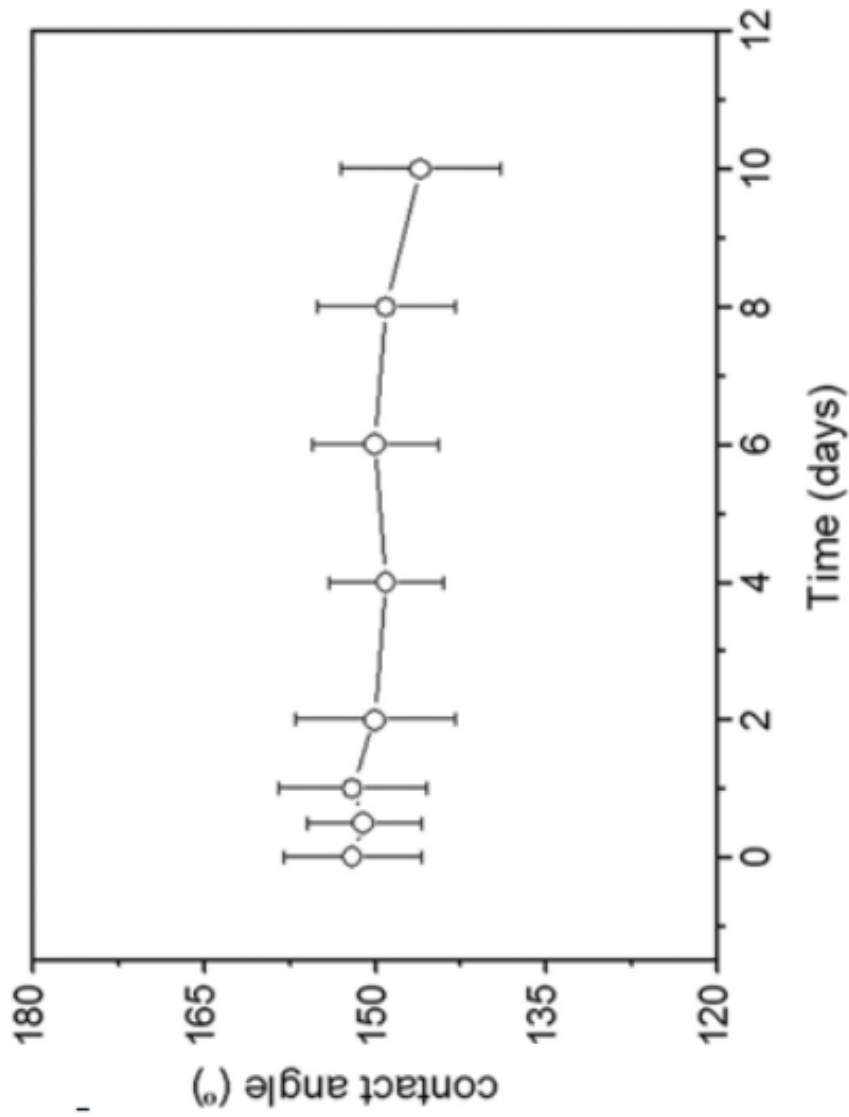

FIG. 21