

# Information Technologies for Assessing the Quality of IT-specialties Graduates' Training of University by Means of Fuzzy Logic and Neural Networks

Anzhelika O. Azarova, Larysa E. Azarova, Sergii V. Pavlov, Nataliia B. Savina, Iryna S. Kaplun, Waldemar Wójcik, Saule Smailova, and Aliya Kalizhanova

**Abstract**—The information technologies for assessing the quality of IT-specialties graduates' training of university by means of fuzzy logic and neural networks are developed in the article. It makes possible taking into account a wide set of estimation and output parameters, influence of the external and internal factors and allows to simplify the assessing process by means of modern mathematical apparatuses of artificial intelligence.

**Keywords**— information technologies, fuzzy logic, neural networks, quality of IT-specialties graduates' training

## I. INTRODUCTION

THE modernization of higher education, the necessity of its transition to a new level that corresponds to the modern needs of specialists for high-tech firms and enterprises is associated with a significant transformation of the functions of their professional activities, and therefore the necessity of new professional competences formation. Such a situation requires the fundamentals changes in the professional estimation of the quality level of training specialists in the technical profile.

To solve the various personnel problems, which have the heads of production and non-production structures, to make their decisions on time, it is necessary to analyze the real labor market, which is formed mainly on the basis of graduates of higher education, to simulate its future development, to take into account possible risks and uncertainty. This becomes possible on the basis of methods of mathematical modeling by means of artificial intelligence with using of modern information technologies, which will promote the adoption of optimal solutions at different levels of management.

Anzhelika O. Azarova, Larysa E. Azarova and Iryna S. Kaplun, are with Vinnytsia National Technical University, Ukraine (e-mail: azarova.angelika@gmail.com).

Sergii V. Pavlov is with Vinnytsia National Technical University, Ukraine (e-mail: psv@vntu.edu.ua).

Nataliia B. Savina, is with National University of Water and Environmental Engineering, Rivne, Ukraine (e-mail: n.b.savina@nuwm.edu.ua).

Waldemar Wójcik is with Lublin University of Technology, Lublin, Poland, (e-mail: waldemar.wojcik@pollub.pl)

Saule Smailova is with East Kazakhstan State Technical University named after D.Serikbayev, Ust-Kamenogorsk, Kazakhstan, (e-mail: saule\_smailova@mail.ru).

Aliya Kalizhanova is with Institute of Information and Computational Technologies CS MES RK and Al-Farabi Kazakh National University, Almaty, Kazakhstan (e-mail: kalizhanova\_aliya@mail.ru).

In scientific studies, considerable attention is paid to the methods of training of technical specialists thanks to the works of V. Y. Bobrov, L. O. Kanischenko, K. F. Berkit, E. M. Kalitskiy, V. Y. Strelnikov, O. V. Kuklin, J. Brinkel, V. V. Valeshnyi, G. O. Kovalchuk, V. A. Kozakov and others. At the same time, there are unresolved problems both in the theoretical and applied aspects, which make accurate evaluating the level of graduates training of technical universities impossible due to lack of a clearly formalized approach to such a process by automated means. It should be noted that the apparatus of artificial intelligence, namely fuzzy logic and neural networks, enables the computerization of the procedure for the solution of classification tasks, which are considered in the article.

The newest professional training of students of higher education should be universal, adapted to the modern labor market, using a person-oriented approach to the learning process, its informatization and continuity. It has to form specialists with economic and technology thinking, rational attitude to the chosen profession in the conditions of integration processes taking place in the Ukraine; to equip specialists with theoretical knowledge and practical skills of the peculiarities of work, of the forming the necessity for a vision perspective.

One of the most productive ways to take into account the above requirements for the estimation the quality level of graduates training is the using of fuzzy logic (FL) and Hopfield neural networks. A fuzzy-logical approach allows getting fundamental evaluation for qualitative parameters and its formalization. The Hopfield neural network identifies the quality level of specialists training with using a limited number of reference samples, which significantly reduces the time and money costs of making the appropriate decision.

All of the above-mentioned factors determine the necessity of the development of appropriate mathematical models and methodological approaches to the estimation of the quality level of graduates training of technical university by means of artificial intelligence.

The purpose of the article is formalization of the process of estimating the quality level of graduates training in technical universities for further improvement through the formation of appropriate complex target program.



## II. DEVELOPMENT OF MODELS

The mathematical model for estimating the quality level of graduates training in technical universities had to include a set of input and output parameters, which should take into account wide spectrum of them and satisfy the conditions of fullness, efficiency and minimum. To do this, at first, according to the criterion of fullness, it is necessary to select such a number of input estimation parameters, so that they as wide as possible characterize the level of graduates training on the basis of analysis of all its elements of influence. Limitation of the formed set of estimation parameters on the criterion of efficiency allows allocating parameters with the maximum degree of effectiveness. Further reduction of the set should be done taking into account the criterion of minimum, that is, the exclusion of all collinear, correlated parameters etc.

The authors of the article offer the mathematical model for estimating the quality level of graduates training in technical universities of the following type

$$\begin{aligned} X^* \rightarrow Y, X^* = \{x_p\}, p = \overline{1, P}, X = f(X^*), X = (x_{ij}), i = \overline{1, n}, j \in M, Y = (y_s), s = \overline{1, 3}; \\ Y = F(f_1, \dots, f_5), \\ f_1 = f(x_{11}, \dots, x_{17}), f_2 = f(x_{21}, \dots, x_{25}), f_3 = f(x_{31}, \dots, x_{37}), f_4 = f(x_{41}, \dots, x_{45}), f_5 = f(x_{51}, \dots, x_{510}) \end{aligned}$$

where  $F$  is the functional of mapping, based on the following functions:

- $f_1$  – estimation of the level of psychophysical qualities of the graduate –  $f_1 = f(x_{11}, \dots, x_{17})$ ;
- $f_2$  – estimation of the level of fundamentals training and professional knowledge of the graduate –  $f_2 = f(x_{21}, \dots, x_{25})$ ;
- $f_3$  – estimation of the level of personal qualities of the graduate –  $f_3 = f(x_{31}, \dots, x_{37})$ ;
- $f_4$  – estimation of the level of professional abilities of the graduate –  $f_4 = f(x_{41}, \dots, x_{45})$ ;
- $f_5$  – estimation of the level of professional skills of the graduate –  $f_5 = f(x_{51}, \dots, x_{510})$ .

In turn, the estimating parameters for these functions are:  $x_{11}$  – visual perception,  $x_{12}$  – auditory perception,  $x_{13}$  – memory (mnemonic actions),  $x_{14}$  – imagination (imative actions),  $x_{15}$  – oral language (interpersonal actions),  $x_{16}$  – emotionally-voluntary regulation (self-control),  $x_{17}$  – psychomotorics (motor actions);  $x_{21}$  – the level of intellectual development,  $x_{22}$  – knowledge of the humanities and social sciences,  $x_{23}$  – level of knowledge of professionally oriented disciplines,  $x_{24}$  – level of system training,  $x_{25}$  – ability to self-study;  $x_{31}$  – attentiveness (external control actions),  $x_{32}$  – commitment (interpersonal actions),  $x_{33}$  – intellectual skills,  $x_{34}$  – interpersonal communication skills,  $x_{35}$  – level of discipline,  $x_{36}$  – compromise,  $x_{37}$  – self-organization and responsibility,  $x_{37}$  – level of social adaptation (ability to work together);  $x_{41}$  – technical abilities (abilities to master and use technical abilities),  $x_{42}$  – verbal-logical abilities (communication skills, logical actions),  $x_{43}$  – social and organizational skills,  $x_{44}$  – level of cultural, ethical and moral education,  $x_{45}$  – ability to substantiate and choose the best solution;  $x_{51}$  – level of experience in the analysis of complex problems, their effective solution,  $x_{52}$  – readiness to work in crisis situations, ability to work in enterprises and organizations, regardless of ownership,  $x_{53}$  – the ability to generate new ideas, to think creatively, to

correctly process information,  $x_{54}$  – the level of professional competitiveness,  $x_{55}$  – the ability to study and predict consumer demand,  $x_{56}$  – the ability to develop strategies and conduct advertising,  $x_{57}$  – the ability to data processing by means of specialized information systems,  $x_{58}$  – the ability to support modern Internet business management technologies,  $x_{59}$  – the ability to protect the business information in computer systems,  $x_{510}$  – the ability to properly publicize the results of its activities[6,7,8]. The structural model of the formalization process of the above mathematical model is presented in Fig. 1

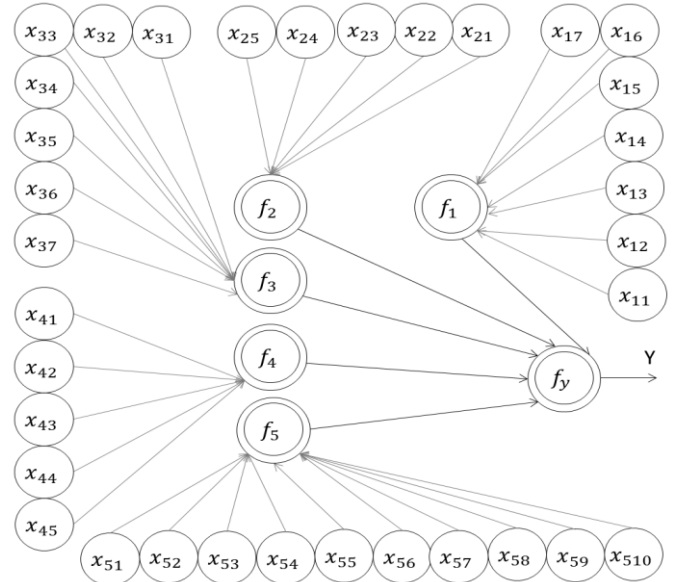

Fig. 1. Structural model of the process of estimating the quality level of graduates training

Since a potential employer who estimates the level of graduate training is able to analyze  $7 \pm 2$  factors [1] and to take a personnel solution without fail with a high degree of accuracy, then it is expedient according to the criteria of fullness and efficiency to formulate such a set of output decisions  $Y = (y_s), s = \overline{1, 3}$ :

- $y1$  – high quality level of graduates training [9-12];
- $y2$  – middle level of graduates training;
- $y3$  – low quality level of graduates training in technical universities.

## III. STAGE 1

The first stage consists in the procedure for formalization the mathematical model on the basis of fuzzy logic apparatus. Quantitative and qualitative estimating parameters are calculated on the basis of the set of input initial parameters  $X^*$ . For mapping the set of input initial parameters  $X^*$  on the set of aggregative function  $f_1$ – $f_5$ , we use the mathematical apparatus of fuzzy sets. Fuzzy logic has a special advantage in solving the problem, taking into account the necessity of the obtaining of qualitative parameters fundamental evaluations.

For the evaluation parameters we will use a single scale of linguistic terms:  $L$  – low,  $M$  – middle,  $H$  – high. The set  $X$  of estimation parameters consists of the quantitative:  $x_{11}, x_{12}, x_{13}, x_{21}$  and qualitative parameters of influence (the other rest in the set  $X$ ). Since for the estimation of the functions of belonging for parameters  $x_{ij}$  it is necessary to find the meaning of the

linguistic terms of these indicators, then for such qualitative parameters, the approach below is proposed.

Consider, for example, the estimating of the qualitative parameter  $x_{51}$  – the level of experience in the analysis of complex problems and their effective solution – an appropriate linguistic term based on such qualitative parameters: qualifications of employees, work experience and availability of higher education. We offer such an algorithm for calculating the parameter  $x_{51}$ , the graph-diagram of which is shown in Fig. 2. Here A – analysis of the employee's personal card; B – high level of qualification; C – high level of success of the tasks to be solved; D – a high degree of complexity and unstructuredness of solvable problems.

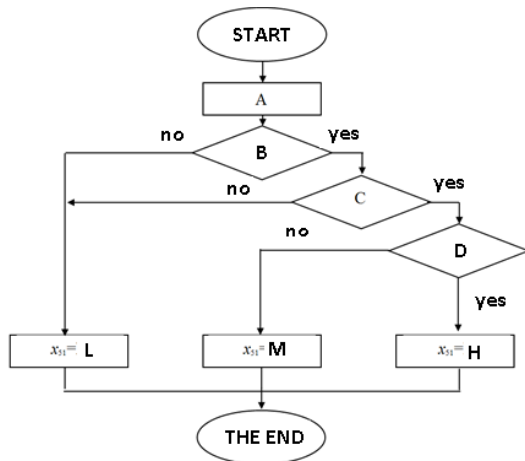

Fig. 2. Graphic diagram of the algorithm for determining the linguistic value of parameter  $x_{51}$

To determine the parameter  $x_{53}$  – the level of professional competitiveness – it is proposed to use the characteristics that describe it most fully and have a ball score value (Table I).

TABLE I

Professional characteristics of the manager image evaluation

The name of the parameter	Ball score of parameter – $b^t$
Level of special knowledge	[0–5]
Competence	[0–5]
The ability to make decisions	[0–5]
Employee trust	[0–4]
Efficiency	[0–2]
Communicative	[0–2]

Taking the expert knowledges of input parameters (described in Table I) influence to the level of professional competitiveness, the calculation of the  $x_{53}$  parameter is proposed using the following ratio:

$$x_{53} = \begin{cases} L, & \text{if } 0 \leq \sum_{i=1}^6 b_t \leq 8; \\ M, & \text{if } 8 < \sum_{i=1}^6 b_t \leq 14; \\ H, & \text{if } 14 \leq \sum_{i=1}^6 b_t \leq 23. \end{cases}$$

Similarly, it is possible to identify the values of all other qualitative estimation parameters  $x_{ij}$  of set X. There are relevant formulas for calculation for quantitative parameters –  $x_{11}, x_{12}, x_{13}, x_{21}$  [2].

After estimating the values of the set of input parameters, we calculate the values of their functions of belonging. To do this, we define the functions of belonging  $\mu^t(x_{ij})$  for each parameter  $x_{ij}$  separately.

Each quantitative parameter is described by a separate function of belonging to three fuzzy terms as it shown in Fig.3

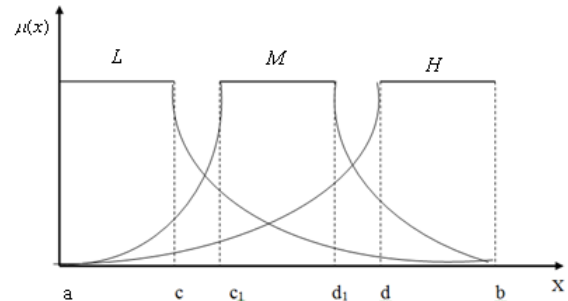

Fig. 3. Functions of belonging of three fuzzy terms for quantitative parameters

$$\mu^L(x_{ij}) = \begin{cases} 1, & x_{ij} \in [a, c]; \\ \left(\frac{b - x_{ij}}{b - c}\right)^{1.5}, & x_{ij} \in [c, b], \end{cases} \quad \mu^M(x_{ij}) = \begin{cases} \left(\frac{x_{ij} - a}{c_1 - a}\right)^{1.5}, & x_{ij} \in [a, c_1]; \\ 1, & x_{ij} \in (c_1, d_1); \\ \left(\frac{b - x_{ij}}{b - d_1}\right)^{1.5}, & x_{ij} \in [d_1, b], \end{cases}$$

$$\mu^H(x_{ij}) = \begin{cases} \left(\frac{x_{ij} - a}{d - a}\right)^{1.5}, & x_{ij} \in [a, d]; \\ 1, & x_{ij} \in (d, b]. \end{cases}$$

The values  $c, c_1, d_1, d, b$  for each quantitative parameter are determined based on the proposed range of parameter changes. The qualitative parameters  $x_{ij}, j \in M$ , the authors also suggest to describe with corresponding linguistic term  $t, t = \overline{1, T}$  from the set of terms  $T$ . We choose 3 linguistic terms ( $T = 3$ ): ( $t_1 - H; t_2 - M; t_3 - L$ ). For  $T = 3$  we will construct graphs of belonging functions, as it shown on Fig. 4 [3].

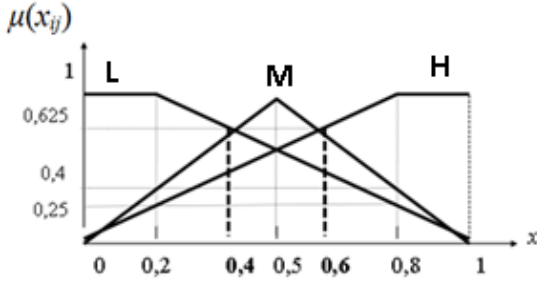

Fig. 4. Membership functions for qualitative parameters

Based on the function graphs, the value  $\mu^t(x_{ij})$  we'll determine such way. If the qualitative parameter is characterized by the term „low” (L), then the value of belonging function are determined for  $x = 0,2$  and  $\mu^L(0,2) = 1$ ;  $\mu^M(0,2) = 0,4$ ;  $\mu^H(0,2) = 0,25$ . If the qualitative parameter is described by the term „middle” (M), then  $\mu^M(0,5) = 1$ ;  $\mu^L(0,5) = \mu^H(0,5) = 0,625$ . For the term „high” (H):  $\mu^L(0,8) = 0,25$ ;  $\mu^M(0,8) = 0,4$ ;  $\mu^H(0,8) = 1$ . These exact values of the belonging functions are obtained on the basis of analytic expressions of the corresponding functions for  $x = 0,2$ ;  $0,5$ ;  $0,8$ . The whole set of belonging functions values for  $t = 3$  is given in Table II.

TABLE II  
Values of belonging functions for  $t = 3$  for qualitative parameters

Term	$\mu^L(x)$	$\mu^M(x)$	$\mu^H(x)$
L	1	0,4	0,25
M	0,625	1	0,625
H	0,25	0,4	1

To determine mathematical expressions describing the functions of belonging of qualitative parameters, we use the equation of the straight line. So we obtain the following expressions for describing the type of belonging functions:

$$\mu^L(x_{ij}) = \begin{cases} 1, & x_{ij} \in [0, 0,2]; \\ \left(\frac{1-x_{ij}}{0,8}\right)^{1,5}, & x_{ij} \in (0,2,1], \\ \frac{x_{ij}}{0,5}, & x_{ij} \in [0,0,5]; \\ \left(\frac{1-x_{ij}}{0,5}\right)^{1,5}, & x_{ij} \in (0,5,1], \\ \frac{x_{ij}}{0,8}, & x \in [0, 0,8]; \\ 1, & x_{ij} \in (0,8, 1]. \end{cases} \mu^M(x_{ij})$$

The process of evaluating the graduates training quality level on the basis of the mathematical apparatus of fuzzy logic should contain a mechanism of a clear logical conclusion for the determination of  $y_s$ ,  $s = \overline{1,3}$ , based on the corresponding source information [4]. Therefore, the necessary stage of the analysis is the formation of knowledge matrices, which were compiled for each  $f_i(x_{ij})$ ,  $i = \overline{1,n}$ ,  $j \in M$  to evaluate the belonging of the functions  $f_1 - f_5$  values to the above terms  $\tau_i$  and obtain the corresponding logical equations:

$$\begin{aligned} \mu^{\tau_t}(f_1) &= \max_{r=1}^7 \left\{ \min \left[ \mu^{tr7}_{j=1}(x_{1j}) \right] \right\}; \quad \mu^{\tau_t}(f_2) = \max_{r=1}^7 \\ &= \left\{ \min \left[ \mu^{tr5}_{j=1}(x_{2j}) \right] \right\}; \\ \mu^{\tau_t}(f_3) &= \max_{r=1}^7 \left\{ \min \left[ \mu^{tr7}_{j=1}(x_{3j}) \right] \right\}; \quad \mu^{\tau_t}(f_4) = \\ &= \max_{r=1}^7 \left\{ \min \left[ \mu^{tr5}_{j=1}(x_{4j}) \right] \right\}; \\ \mu^{\tau_t}(f_5) &= \max_{r=1}^7 \left\{ \min \left[ \mu^{tr10}_{j=1}(x_{5j}) \right] \right\}, \end{aligned}$$

where  $r$  is the line number in the set of values for the function  $f_i$ ,  $i = (\overline{1,5})$  and  $j$  is the number of the estimating parameter in the subset of the parameters  $x_{ij}$ , that determine the aggregation function  $f_i$ .

Thus, for the evaluation of the function  $f_i$  – estimation of the level of psychophysical qualities of the graduate – the experts compiled the following logical equations that determine its level and have such form:

$$\begin{aligned} \mu_{f_1}^H &= \mu^H(x_{11}, \dots, x_{17}) \\ &= \mu^H(x_{11}) \cdot \mu^H(x_{12}) \cdot \mu^H(x_{13}) \cdot \mu^H(x_{14}) \\ &\quad \cdot \mu^H(x_{15}) \cdot \mu^H(x_{16}) \cdot \mu^H(x_{17}) \vee \\ &\quad \vee \mu^H(x_{11}) \cdot \mu^H(x_{12}) \cdot \mu^H(x_{13}) \cdot \mu^H(x_{14}) \cdot \mu^M(x_{15}) \cdot \mu^H(x_{16}) \\ &\quad \cdot \mu^H(x_{17}) \vee \\ &\quad \vee \mu^H(x_{11}) \cdot \mu^H(x_{12}) \cdot \mu^H(x_{13}) \cdot \mu^H(x_{14}) \cdot \mu^M(x_{15}) \cdot \mu^H(x_{16}) \\ &\quad \cdot \mu^H(x_{17}) \vee \\ &\quad \vee \mu^H(x_{11}) \cdot \mu^H(x_{12}) \cdot \mu^H(x_{13}) \cdot \mu^M(x_{14}) \cdot \mu^H(x_{15}) \cdot \mu^H(x_{16}) \\ &\quad \cdot \mu^H(x_{17}) \vee \\ &\quad \vee \mu^H(x_{11}) \cdot \mu^H(x_{12}) \cdot \mu^M(x_{13}) \cdot \mu^H(x_{14}) \cdot \mu^H(x_{15}) \cdot \mu^H(x_{16}) \\ &\quad \cdot \mu^H(x_{17}) \vee \\ &\quad \vee \mu^H(x_{11}) \cdot \mu^M(x_{12}) \cdot \mu^H(x_{13}) \cdot \mu^H(x_{14}) \cdot \mu^H(x_{15}) \cdot \mu^H(x_{16}) \\ &\quad \cdot \mu^H(x_{17}) \vee \\ &\quad \vee \mu^M(x_{11}) \cdot \mu^H(x_{12}) \cdot \mu^H(x_{13}) \cdot \mu^H(x_{14}) \cdot \mu^H(x_{15}) \cdot \mu^H(x_{16}) \\ &\quad \cdot \mu^H(x_{17}); \end{aligned}$$

$$\begin{aligned} \mu_{f_1}^M &= \mu^M(x_{11}, \dots, x_{17}) \\ &= \mu^M(x_{11}) \cdot \mu^M(x_{12}) \cdot \mu^M(x_{13}) \cdot \mu^M(x_{14}) \\ &\quad \cdot \mu^M(x_{15}) \cdot \mu^M(x_{16}) \cdot \mu^M(x_{17}) \vee \\ &\quad \vee \mu^M(x_{11}) \cdot \mu^H(x_{12}) \cdot \mu^H(x_{13}) \cdot \mu^M(x_{14}) \cdot \mu^M(x_{15}) \cdot \mu^M(x_{16}) \\ &\quad \cdot \mu^M(x_{17}) \vee \\ &\quad \vee \mu^M(x_{11}) \cdot \mu^M(x_{12}) \cdot \mu^H(x_{13}) \cdot \mu^H(x_{14}) \cdot \mu^M(x_{15}) \cdot \mu^M(x_{16}) \\ &\quad \cdot \mu^M(x_{17}) \vee \\ &\quad \vee \mu^M(x_{11}) \cdot \mu^M(x_{12}) \cdot \mu^M(x_{13}) \cdot \mu^H(x_{14}) \cdot \mu^H(x_{15}) \cdot \mu^M(x_{16}) \\ &\quad \cdot \mu^M(x_{17}) \vee \\ &\quad \vee \mu^M(x_{11}) \cdot \mu^M(x_{12}) \cdot \mu^M(x_{13}) \cdot \mu^M(x_{14}) \cdot \mu^H(x_{15}) \cdot \mu^H(x_{16}) \\ &\quad \cdot \mu^M(x_{17}) \vee \\ &\quad \vee \mu^M(x_{11}) \cdot \mu^M(x_{12}) \cdot \mu^M(x_{13}) \cdot \mu^M(x_{14}) \cdot \mu^M(x_{15}) \cdot \mu^H(x_{16}) \\ &\quad \cdot \mu^H(x_{17}) \vee \\ &\quad \vee \mu^M(x_{11}) \cdot \mu^H(x_{12}) \cdot \mu^H(x_{13}) \cdot \mu^H(x_{14}) \cdot \mu^M(x_{15}) \cdot \mu^M(x_{16}) \\ &\quad \cdot \mu^M(x_{17}); \end{aligned}$$

$$\begin{aligned} \mu_{f_1}^L &= \mu^L(x_{11}, \dots, x_{17}) \\ &= \mu^L(x_{11}) \cdot \mu^L(x_{12}) \cdot \mu^L(x_{13}) \cdot \mu^L(x_{14}) \\ &\quad \cdot \mu^L(x_{15}) \cdot \mu^L(x_{16}) \cdot \mu^L(x_{17}) \vee \\ &\quad \vee \mu^L(x_{11}) \cdot \mu^L(x_{12}) \cdot \mu^L(x_{13}) \cdot \mu^L(x_{14}) \cdot \mu^L(x_{15}) \cdot \mu^M(x_{16}) \\ &\quad \cdot \mu^L(x_{17}) \vee \\ &\quad \vee \mu^L(x_{11}) \cdot \mu^L(x_{12}) \cdot \mu^L(x_{13}) \cdot \mu^L(x_{14}) \cdot \mu^M(x_{15}) \cdot \mu^L(x_{16}) \\ &\quad \cdot \mu^L(x_{17}) \vee \\ &\quad \vee \mu^L(x_{11}) \cdot \mu^L(x_{12}) \cdot \mu^L(x_{13}) \cdot \mu^M(x_{14}) \cdot \mu^L(x_{15}) \cdot \mu^L(x_{16}) \\ &\quad \cdot \mu^L(x_{17}) \vee \end{aligned}$$

$$\begin{aligned} & \vee \mu^L(x_{11}) \cdot \mu^L(x_{12}) \cdot \mu^M(x_{13}) \cdot \mu^L(x_{14}) \cdot \mu^L(x_{15}) \cdot \mu^L(x_{16}) \\ & \quad \cdot \mu^L(x_{17}) \vee \\ & \vee \mu^L(x_{11}) \cdot \mu^M(x_{12}) \cdot \mu^L(x_{13}) \cdot \mu^L(x_{14}) \cdot \mu^L(x_{15}) \cdot \mu^L(x_{16}) \\ & \quad \cdot \mu^L(x_{17}) \vee \\ & \vee \mu^M(x_{11}) \cdot \mu^L(x_{12}) \cdot \mu^L(x_{13}) \cdot \mu^L(x_{14}) \cdot \mu^L(x_{15}) \cdot \mu^L(x_{16}) \\ & \quad \cdot \mu^L(x_{17}). \end{aligned}$$

In these functions, the sign “ $\vee$ ”, denotes the logical operation „OR”. The logical operation „AND” is indicated by “ $\cdot$ ”. Therefore, to determine the desired result on the basis of a logical record of belonging functions, which are combined by operations AND (“ $\cdot$ ”), it’s necessary to choose the minimum value of them. To determine the desired result on the basis of a logical record of belonging functions, which are combined by operations “ $\vee$ ”, („OR”) it’s necessary to choose the maximum value of them. Thus,  $\mu^{\tau t}(f_1) = \max_{r=1}^7 \left\{ \min \left[ \mu^{tr}{}_{j=1}^7(x_{1j}) \right] \right\}$ . Similar matrices of knowledge and corresponding logical equations are compiled for the remaining four functions  $f_2(x_{ij}) - f_5(x_{ij})$ .

Consequently, the process of evaluating of quality level of graduates training in technical universities consists of two stages. On the first stage, it’s necessary to evaluate (by means of fuzzy logic apparatus) the linguistic values of aggregative functions  $f_1 - f_5$ , characterized by linguistic terms  $\tau_i \in (L, M, H)$ . On the second stage, it’s necessary to define (by means of Hopfield network) the belonging of combinations of input linguistic values of aggregative functions  $f_1 - f_5$  to the one of the possible output levels (low, middle, high) of quality of graduates training.

**STAGE 2.**

Stage 2 consists in the procedure for formalization of the mathematical model of estimating the quality level of graduates training in technical universities on the basis of Hopfield’s neural network

The process of estimating the quality level of graduates training consists of two stages: the first one –evaluating of linguistic values of aggregative functions  $f_1 - f_5$ , characterized by the three above terms  $\tau_i$ ; the other one – the second stage – based on the Hopfield neural network the belonging of level of graduates training to one of the possible result levels is defined.

At stage 2, to identify output result  $y_s, s = \overline{1,3}$ , authors propose Hopfield’s neural network, inputs for which are the linguistic evaluations  $\mu_{f_i}^{\tau_i}$  of aggregative functions  $f_i, i = \overline{1,5}$ , obtained at stage 1. Proceeding from the specifics of the Hopfield’s network [5], the authors propose on its inputs to enter the binaries codes  $z_i$  («1» and «-1») of the linguistic evaluations  $\mu_{f_i}^{\tau_i}$  of aggregative functions  $f_i, i = \overline{1,5}$ . We will describe the format of the code with three digits to encode 3 linguistic terms: low level of  $f_i - (-1,-1,-1)$ ; the middle level of the function  $f_i - (-1, 1, 1)$ ; the high level of the function  $f_i - (1, 1, 1)$ .

The proposed Hopfield’s network (Fig. 5) allows to compare the image of the input vector  $Z = (z_l), l = \overline{1,L}, L = 15$ , which describes the codes of values of aggregative functions  $f_i, i = \overline{1,5}$ , with 3 standard samples (Tabl. 3). It makes possible to determine the nearest standard vector  $U=(u_i)$  (system output).

TABLE III

Standard samples for estimation of  $y_s (s = \overline{1,3})$  levels

$f_1$	$f_2$	$f_3$	$f_4$	$f_5$	$y_s$
111	111	111	111	111	$y_1$
-111	-111	-111	-111	-111	$y_2$
-1-1-1	-1-1-1	-1-1-1	-1-1-1	-1-1-1	$y_3$

Thus, the network identifies that standard sample, which is most similar to the one described above. Each standard sample determines a certain level of quality of graduates training –  $y_s, s = \overline{1,3}$ .

**IV. RESULTS**

After encoding, the Hopfield’s network compares the input vector, which characterizes the level of quality of graduates training, with 3 standard samples given in Table III, compiled on the basis of expert data.

On the example of graduate students of the specialty „Information security management” of Vinnytsia National Technical University, on the basis of the above approach, based on the fuzzy logic, the following values of aggregative functions  $f_i$  were obtained:  $f_1 = M, f_2 = H, f_3 = M, f_4 = H, f_5 = H$ . We present these linguistic estimates of functions  $f_i$  with corresponding codes as shown in Table IV.

TABLE IV

Values of aggregative functions  $f_i, (i = \overline{1,5})$

Values of $f_i$	Encoding
$f_1 = M$	-1 1 1
$f_2 = H$	1 1 1
$f_3 = M$	-1 1 1
$f_4 = H$	1 1 1
$f_5 = H$	1 1 1

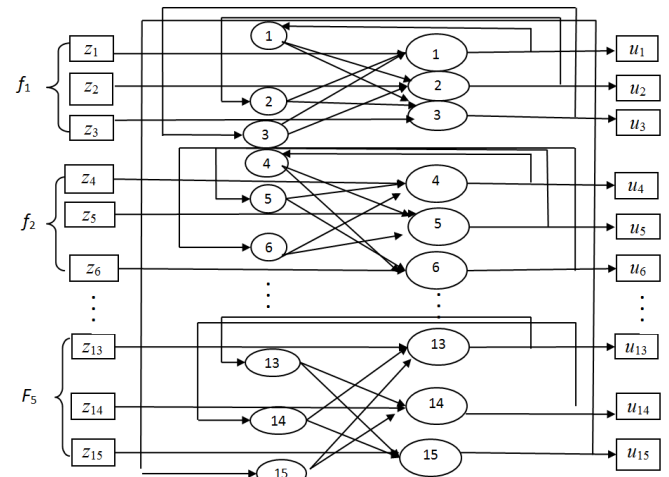

Fig. 5. Structure of the Hopfield’s neural network for estimating the quality level of graduates training in technical university

The realization of the Hopfield’s neural network was carried out using the mathematical package MatLab. So, identification of the level of quality of graduates training is illustrated by the appropriate excerpt of this program:

T= [1 1 1 1 1 1 1 1 1 1 1 1 1 1 1]



```

-1 1 1 -1 1 1 -1 1 1 -1 1 1 -1 1 1
-1 -1 -1 -1 -1 -1 -1 -1 -1 -1 -1 -1 -1 -1 -1];
net=newHop(T);
X={[-1 1 1 1 1 1 -1 1 1 1 1 1 1 1 1]};
[a,b,c]=sim(net,{1 1000},{},X);
a{1000}

```

So, the result output is: ans = [1 1 1 1 1 1 1 1 1 1 1 1 1 1 1]  
Comparing the obtained vector  $X = [-1 1 1 1 1 1 -1 1 1 1 1 1 1 1 1 1]$  (Table IV) with the standard samples, which are presented in Table III, it can be noted that the quality level of graduates training of the specialty “Information security management” of Vinnytsia National Technical University corresponds to the value of  $y_1$ , which is high.

## V. CONCLUSIONS

The mathematical model and methods of its formalization, which allows describing the procedure for estimating the quality level of graduates training of technical universities is proposed in the article. Such model maps the set of input parameters on the set of output decisions. In this case, the set of input parameters is formed from the main elements of influence on the quality level of graduates training, which are united into blocks – aggregative functions  $f_i$ , which make possible the complex characterization of the estimation procedure ( $f_1$  – estimation of the psychophysical qualities level of the graduate –  $f_1 = f(x_{11}, \dots, x_{17})$ ;  $f_2$  – estimation of the level of fundamental training and professional knowledge of the graduate –  $f_2 = f(x_{21}, \dots, x_{25})$ ;  $f_3$  – estimation of the level of personal qualities of the graduate –  $f_3 = f(x_{31}, \dots, x_{37})$ ;  $f_4$  – estimation of the level of professional abilities of the graduate –  $f_4 = f(x_{41}, \dots, x_{45})$ ;  $f_5$  – estimation of the level of professional skills of the graduate –  $f_5 = f(x_{51}, \dots, x_{510})$ ).

The set of output parameters  $\mathbf{Y} = (y_s)$ ,  $s = \overline{1,3}$ , in turn, allows describing all possible quality levels of graduates training ( $y_1$  is a high quality level of graduates training;  $y_2$  – middle quality level;  $y_3$  is a low quality level of graduates training).

The scientific novelty of the obtained results is the formation of methodological principles for estimating the quality level of graduates training on the basis of the mathematical apparatus of artificial intelligence and modern mathematical automated means. In particular, for the first time, it was proposed:

- the mathematical model for estimating the quality level of graduates training of technical universities and the method of its formalization, which based on the mathematical apparatus of fuzzy logic and the Hopfield’s neural network, which allows

precisely and adequately, with a minimum time, to map the set of input parameters to the set of resulting solutions, taking into account the wide range both quantitative and qualitative factors of influence to ensure the complexity and dynamism of such a process;

- the structural model for estimating the quality level of graduates training of technical universities, which, by means of system theory, allows the decomposition of a complex evaluation procedure into a sequence of elementary components, the identification of which becomes clearly formalized.

## REFERENCES

- [1] G. Miller, “The magic number is seven plus or minus two,” *Engineering Psychology*, 1964.
- [2] O. I. Shcherbak, N. Z. Sofiy, and B. Yu. Bovich, “Theory and practice of evaluation of educational achievements: Educational-methodical manual, in For sciences,” Ed. O. I. Shcherbak., I. Frankivsk, Lileia-NW, 2014, pp. 136.
- [3] S. V. Yuhimchuk, and A. O. Azarova, *Mathematical risk models for decision support systems*, Vinnytsya, UNIVERSUM–Vinnitsa, 2003, pp. 188.
- [4] A. O. Azarova, and O. V. Antoniuk, *Mathematical models of the evaluation of enterprise strategic potential and making decision concerning its improvement: monograph*, Vinnitsa, VNTU, 2012, pp. 168.
- [5] V. V. Kruglov, and V. V. Borisov, *Neural networks. Theory and practice*, Moscow : Hotline - Telecom, pp. 382, 2002.
- [6] A. P. Rotshtein, M. Posner, and H. B. Rakytyanska, “Cause and effect analysis by fuzzy relational equations and a genetic algorithm,” *Reliability Engineering and System Safety*, vol. 91, no. 9, pp. 1095-1101, 2006.
- [7] A. P. Rotshtein, and H. B. Rakytyanska, “Diagnosis problem solving using fuzzy relations,” *IEEE Transactions on Fuzzy Systems*, vol. 16, no. 3, pp. 664-675, 2008.
- [8] L. I. Timchenko, “A multistage parallel-hierarchic network as a model of a neuronlike computation scheme,” *Cybernetics and Systems Analysis*, vol. 36, no. 2, pp. 251-267, 2000.
- [9] L. I. Timchenko, Y. F. Kutaev, V. P. Kozhemyako, and etc., “Method for training of a parallel-hierarchical network, based on population coding for processing of extended laser paths images,” *Proceedings of SPIE* 4790, 2002.
- [10] M. F. Kirichenko, Yu. V. Krak, and A. A. Polishchuk, “Pseudo inverse and projective matrices in problems of synthesis of functional transformers,” *Cybernetics and Systems Analysis*, vol. 40, no. 3, pp. 116-129, 2004.
- [11] V. Mosorov, T. Panskyi, S. Biedron, “Modified alternative decision rule in the pre-clustering algorithm,” *Informatyka, Automatyka, Pomiary w Gospodarce i Ochronie Srodowiska – IAPGOS*, vol. 6, no. 2, pp. 9–12, 2016.
- [12] Yu. V. Krak, “Dynamics of manipulation robots: Numerical-analytical method of formation and investigation of computational complexity,” *Journal of Automation and Information Sciences*, vol. 31, no. 1-3, pp. 121-128, 1999.